

enlighten[™]

Instruction and Reference Guide

Model BLE3ATW-2



FOR THE LOVE OF SEWING

To register your machine warranty and receive Baby Lock product updates and offers, go to www.babylock.com/profile. If you have questions with registration, visit your Authorized Baby Lock Retailer.

Baby Lock Consumer Helpline: 800-313-4110

www.babylock.com

Welcome to the Baby Lock Enlighten

The Baby Lock Enlighten has an exclusive "Thread Delivery System" that eliminates confusing tension adjustments. The Enlighten enables you to accomplish a perfect stitch with any type of thread on any type of fabric. You no longer need to guess at the correct tension adjustments.

The Enlighten is equipped with an exclusive Push to Thread "Electronic Extraordin Air Threading System". It is no longer necessary to select the threading position. All looper threads may be threaded at the same time or individually.

Your Baby Lock Enlighten is a high-quality, dependable machine. It gives you the ability to seam, overcast and trim all in one operation. Fabrics and threads you previously avoided are now a joy to sew because the Baby Lock Enlighten handles all varieties with equal ease. With the Baby Lock Enlighten your creative options are endless and your time spent serging is more fulfilling and rewarding. With the "Extraordin Air Threading System", even threading the Enlighten is a breeze.

With proper care and maintenance, your Baby Lock Enlighten promises years of high-quality, dependable performance and sewing pleasure. Keep this instruction manual as a step-by-step guide to become familiar with your Baby Lock Enlighten and expand your sewing horizons.

For additional product information and updates, visit our website at www.babylock.com.

Happy Sewing!

enlighten

Table of Contents

OVERVIEW	4
How Your Serger Operates	4
Overview of the Enlighten	5
ACCESSORIES	6
Accessories	6
Needles	7
Thread	7
Optional Accessories	7
SERGER SET UP	8
Setting Up Your Enlighten	8/9
Threading Your Enlighten	10
Threading Position for Threading	10
Lower Looper	10
Upper Looper	11
Right Needle	12
Left Needle	13
Needle Threader	13
Looper Thread Fine-Tuning Knob	13
SERGING WITH FABRIC	14
Serger with Fabric	14
Clearing the Stitch Width Fingers	14
Thread Delivery System	15
Stitch Selector	15
Wave Selector	15
Re-threading Loopers	15
Re-threading Needles	15
MACHINE SETTINGS	16
Stitch Length / Rolled Hem	16
Stitch Width	16
Differential Feed	17
Disengaging the Upper Cutting Blade	18
Presser Foot Pressure Adjustment	18
Snap-On Presser Foot	18
4-THREAD OVERLOCK	19
4-Thread Overlock	19
3-THREAD OVERLOCK	20
3-Thread Overlock - Wide	20
3-Thread Overlock - Narrow	21
3-Thread Overlock - Narrow Hem	22
Rolled Edging	23
3-Thread Rolled Edge	23
3-Thread Flatlock	24
2-THREAD OVERLOCK	25
2-Thread Overlock	25
Converting from 3-Thread Overlock to 2-Thread Overlock	25
2-Thread Flatlock - Wide	26
2-Thread Flatlock - Narrow	27
Flatlock "Topstitching"	28
Blind Hemming	29
Blanket Stitch - Decorative Stitch	30
Ladder Stitch - Decorative Stitch	31
Returning to 3 or 4-Thread Overlock	32

Table of Contents (Cont.)

WAVE STITCH	33
Wave Stitch	33
Converting from Normal Serging to Wave.....	33
3-Thread Wave Stitch.....	34
3-Thread Rolled Wave Stitch.....	35
ROLLED EDGING	36
Rolled Edging	36
Seaming Sheers.....	36
Lettuce Edge	36
Belt Loops and Button Loops	36
Returning to Standard Serging.....	36
BASIC SERGING TECHNIQUES	37
Overedging.....	37
Seaming	37
Front Cover Seam Guide	37
Securing Ends.....	38/39
Turning Outside Corners	40
Turning Inside Corners.....	40
Serging Curves.....	41
Inserting Tapes	41
USING SPECIALTY THREADS	42
Using Specialty Threads	42
Threading Lightweight Thread.....	42
Changing Threads.....	42
Threading Medium Weight Thread.....	42
Thread Cradle for Loopers	43
Looper Threading Tool	44
Bypassing the Threading Port.....	45
Specialty Thread Guide Chart	46/47
MAINTENANCE	48
Replacing Needles	48
Replacing Cutting Blades	48
Cleaning	49
Replacing LED Lighting.....	49
TROUBLESHOOTING	50
Troubleshooting.....	50/51
Dos and Don'ts	51
TECHNICAL DATA	52
CHART FOR STITCH SELECTION SETTINGS	53

How Your Serger Operates

Sometimes called an overlock machine or overlocker, the serger is different from any conventional sewing machine you have used. Awareness of its simple operation will enable you to become more proficient in its use. Please read all instructions before using your new machine.

Serging is kind of a knitting process that loops two, three or four threads together to create a stitch. Your Baby Lock Enlighten operates with one or two needles and one or two "loopers," each carrying a thread to form the overlock stitch.

When fabric is placed into the machine, it reaches the feed dogs first. The feed dogs move the fabric along as the cutting blades trim the edge, creating a clean edge to be finished. Then the loopers and needle(s) form the stitch on the fabric edge, supported by one or more parallel "stitch fingers" - Metal prongs that keep the fabric flat. The threads become "locked" over the fabric and the resulting stitches encase the raw edge with thread to prevent fabric raveling.

After setting up your machine for the first time, take a few moments to learn how it sews. Before your serger is threaded, turn the handwheel - toward you - and watch the movement and operation of the various parts. Don't bother with fabric at first. It doesn't hurt your serger to stitch without fabric under the presser foot.



Overview of the Enlighten

- | | |
|---|---|
| 1. Presser foot thread release lever* | 16. Threading lever |
| 2. Thread cutter | 17. Threading button |
| 3. Needle threader lever | 18. Differential feed adjusting lever |
| 4. Needle height viewing area | 19. Handwheel |
| 5. Needle clamp screw | 20. Lower looper threading port |
| 6. Snap-on presser foot | 21. Power switch |
| 7. Needle plate | 22. Stitch selector |
| 8. Side cover | 23. Accessory compartment & spool stand |
| 9. Stitch width adjusting dial | 24. Upper looper threading port |
| 10. Cutting blade lock switch | 25. Wave selector |
| 11. Stitch length/rolled hem adjusting dial | 26. Carrying handle |
| 12. Cutting blade cover | 27. Looper thread fine-tuning screw |
| 13. Needle drop drawer | 28. Telescopic thread guide and antenna |
| 14. Subsidiary looper | 29. Needle threader selector |
| 15. Front cover | 30. Presser foot pressure adjusting screw |

* Raising the presser foot releases all threads.

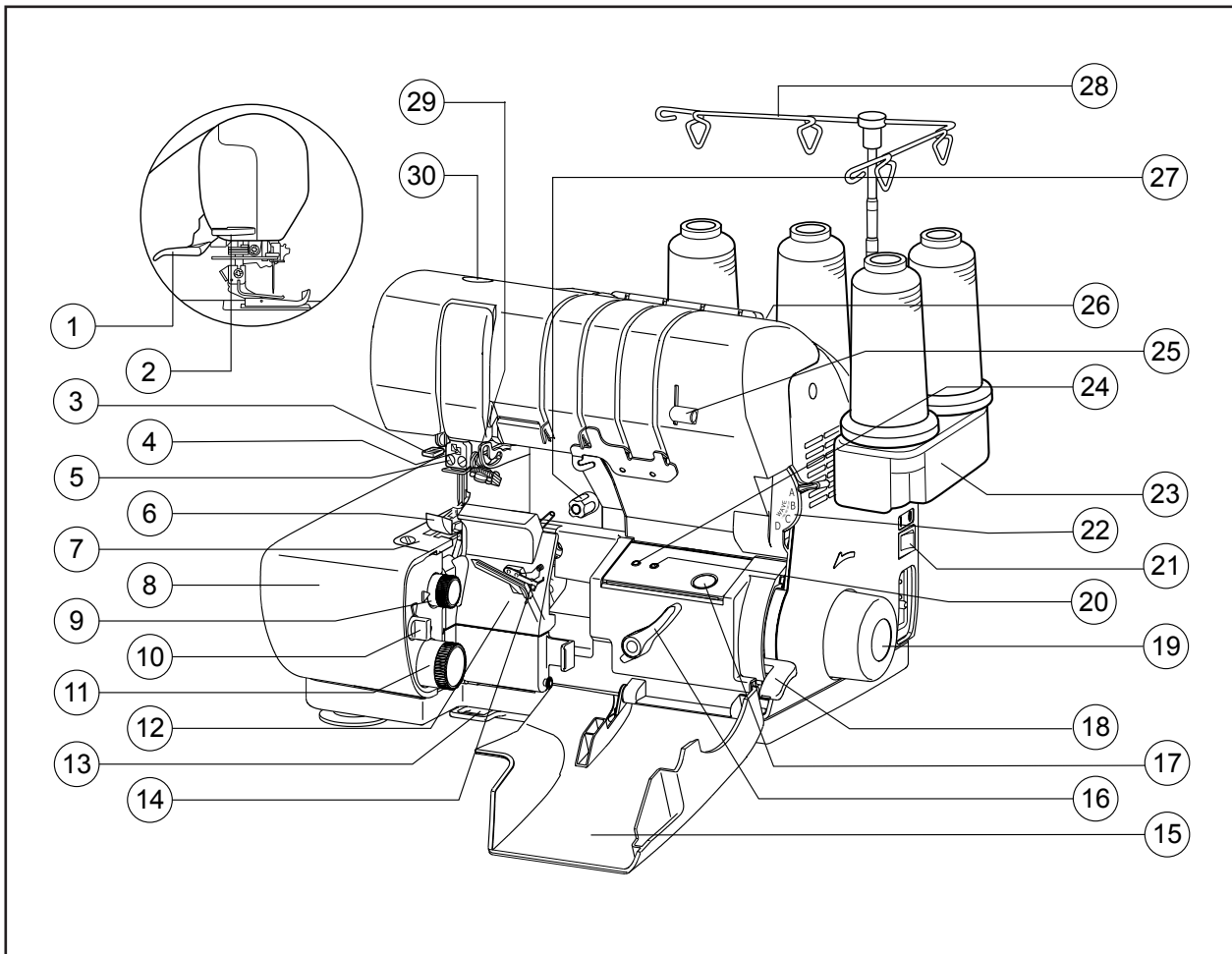

Accessories

Your Baby Lock Enlighten serger has a built-in accessory compartment. To open, swing the "lid" on the thread spoolstand to the right to reveal the tray holding some of the accessories listed below. Others may be found in the machine packing materials.

Accessory	Number included	Located in
Instruction manual	1	Packing box
Quick reference threading guide	1	Packing box
Foot Control	1	Packing box
Lint brush/needle insert tool	1	Accessory compartment
Needle clamp screw	2	Accessory compartment
Package of assorted sized needles Organ ELx705CF	1	Accessory compartment
Medium screwdriver	1	Accessory compartment
Tweezers	1	Accessory compartment
Upper cutting blade for replacement	1	Accessory compartment
Looper threading tool	1	Accessory packet
Screwdriver	1	Accessory packet
Machine cover	1	Accessory packet
Mounting bolt with washer (U.S.A. only)	1	Accessory packet
Thread nets	4	Accessory packet
Spool caps	4	Accessory packet
Sponge disks	4	Accessory packet
Allen wrench	1	Accessory packet
Cone holders	4	On machine

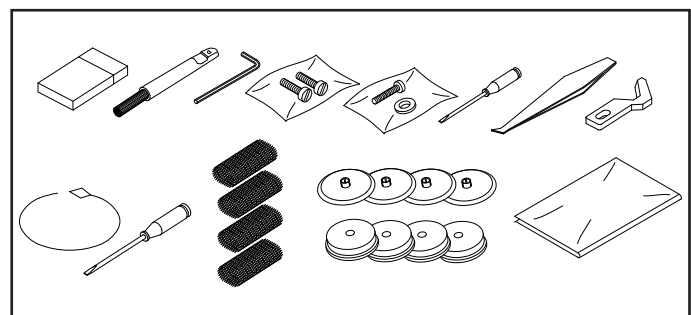
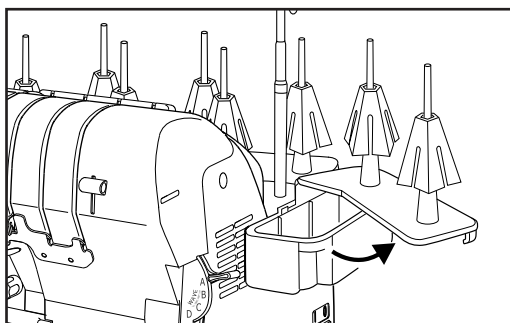

Needles

Your Baby Lock Enlighten serger is set up with 90/14 machine needles, which are suitable for most medium and heavy weight fabrics. For lightweight fabrics, change to a size 75/11 needle. The needle's semi-ball point design is suitable for knits and wovens. Some manufacturers' needles may produce better quality stitches with your Baby Lock than others. For best results, use Organ or Schmetz brand needles - system HAX1SP/CR, and replace them approximately every third project (page 48).

All types of thread may be used on your Baby Lock, but 100% long-staple polyester thread, crosswound on a cone, consistently provides the best stitch performance. Because the threads must pass through several thread guides at high speeds, they must be of uniform thickness and high strength with a minimum amount of linting.

Thread

Good-quality cotton or cotton-covered polyester threads sew well, though they produce more lint, creating the need to clean the machine more frequently. They work well for overedging and seaming, but they may be too weak or too fuzzy for the rolled edge. Poor grades of these threads can result in frequent fraying, breaking and unbalanced stitches.

Threads of other fiber contents and weights may be used, depending on their strength and thickness. Testing will help you determine how easily they can pass through the thread guides, thread slots, needles and loopers. (for more information page 46/47.)

Important Note: For maximum performance of the Baby Lock Enlighten, it is recommended to use "100% polyester-long fiber thread". Recommended brands are Maxi-Lock and Metrosene. This thread also performs best when used with various decorative threads for serging specialty techniques.

Optional Accessories

There are optional snap-on specialty feet available for the Enlighten. The optional accessories are available at your Baby Lock retailer.

- | | | |
|-------------------------------|---------------|---------------|
| • Beading Foot | B5002-01A-C-E | (BLE-BF) |
| • Blindhem Foot | B5002S02A-E | (BLE-BLHFS) |
| • Clear Foot | B5002K02A-E | (BLE3ATW-CLF) |
| • Cording / Piping Foot (3mm) | B5002-02A-C-E | (BLE-CF3) |
| • Cording / Piping Foot (5mm) | B5002-03A-C-E | (BLE-CF5) |
| • Elastic Applicator Foot | B5002S01A-E | (BLE-EF) |
| • Lace Applicator Foot | B5002S05A-E | (BLE-LF) |
| • Ruffling Foot | B5002S03A-E | (BLE-RF) |
| • Size 90 Top Stitch Needle | | (T-90B) |

Setting Up Your Enlighten

After removing the packing materials from the box, gently lift your Baby Lock serger by grasping the handle provided on the top of the machine. Place the machine on a serger sewing table or any level surface that provides ample work area to the left of the machine. Place the foot control in a pedal stay, if desired, and place it under the sewing table.

Plug the power cord into the machine first, then into a wall outlet. The power switch is located toward the back on the right side of the machine. Always make sure the power is OFF when the machine is not in use (fig.A).

Available foot control for U.S.A.: Model YC-482.

This appliance has a polarized plug (one blade wider than the other). To reduce the risk of electric shock, this plug is intended to fit in a polarized outlet only one way. If the plug does not fit fully in the outlet, reverse the plug. If it still does not fit, contact a qualified electrician to install the proper outlet. Do not modify the plug in any way.

The sewing speed of the machine is determined by the amount of pressure applied to the foot control. When not in use, do not place anything on the foot control, or the machine could start inadvertently and the foot control or motor could burn out (fig.A).

Raise the telescopic thread guide to its highest position of 14". Rotate the shaft to the left and right until each section "clicks" into a locked position (fig.B). The front cover may be opened simply by placing your fingers behind the tab at the right side and pulling toward you (fig.C).

To open the cutting blade cover, place your thumb against the tab, and slide the cover to the right. A slight pull forward will allow the cover to swing down, providing access to the loopers, blades, and thread guides (fig.D).

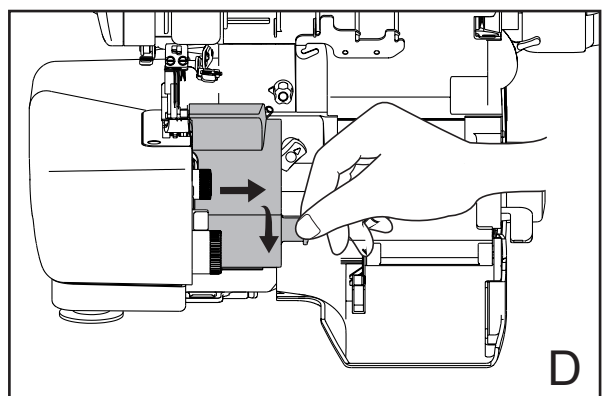
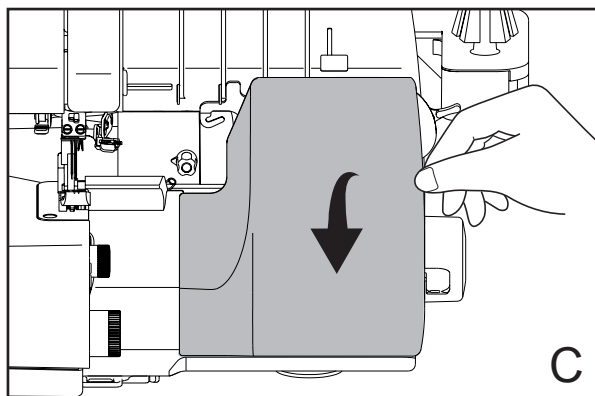
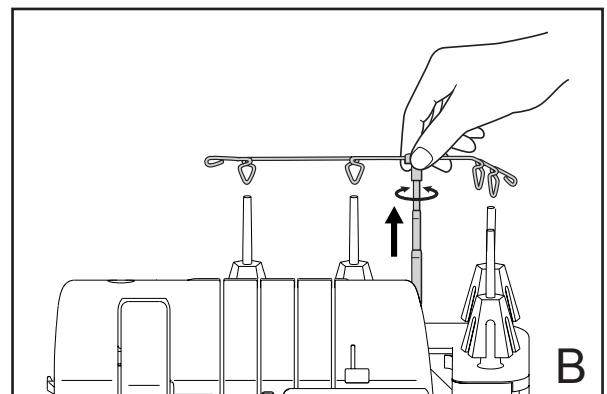
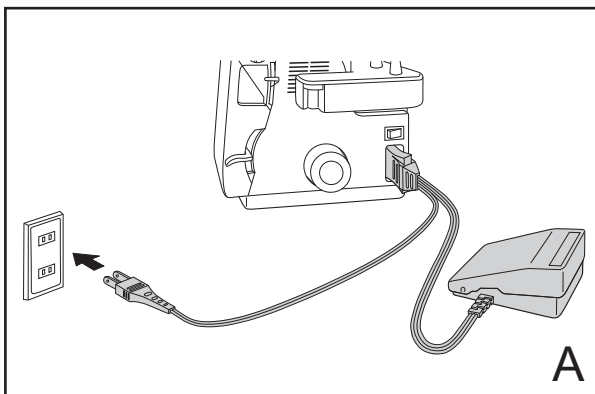

Setting Up Your Enlighten (Cont.)

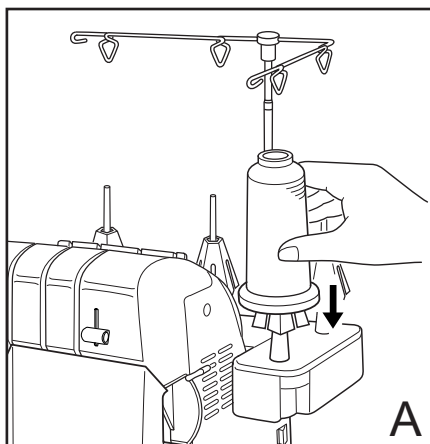

When using threads on cones or king spools place the cone or spool securely over the cone holders furnished on your machine. To avoid bending the thread stand, you may need to place one hand under the stand while positioning the cone. The cone holders prevent the cone or spool from spinning, enabling the thread to feed evenly (fig.A).

Because threads for the serger feed from the top, standard spool threads can snag on the rough edges of many of these spools. That's why spool caps are furnished with your Enlighten to provide a smooth surface that enables the thread to reel off freely. With the spool notch side down, insert a spool cap into the top of the spool (fig.B).

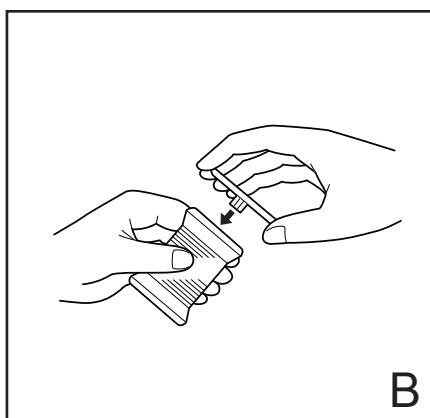

When using standard spool threads on your serger, replace the cone holders with the sponge disks furnished with your machine. These disks hold smaller spools securely and help the thread to reel off properly. With the sponge disk in place, put the capped spool on the spindle (fig.C).

Thread nets may be placed over threads that tend to slip off the bottom of the spool during sewing. Most threads do not require their use, but nets often are necessary with nylon, rayon or silk threads (fig.D). Once it's on the spool, fold the net back on itself, if necessary, to enable the thread to feed smoothly without snagging on the net (fig.E).

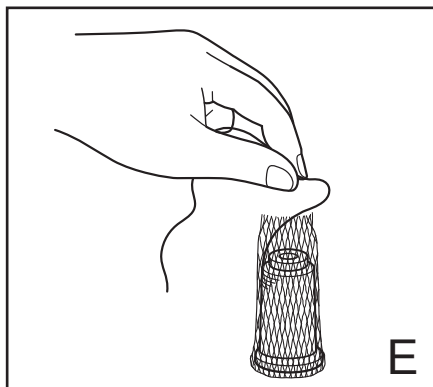
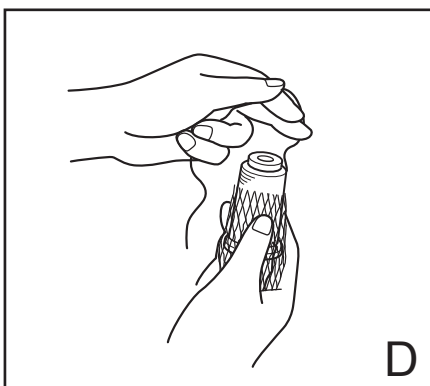
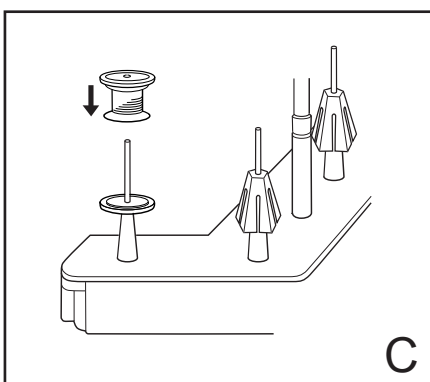

Threading Your Enlighten

Your Baby Lock Enlighten is equipped with an exclusive "Electronic Extraordin Air Threading System" for fast, easy threading of the upper and lower loopers.

One touch of the "Push to Thread" button will automatically thread the loopers. It is no longer necessary to use tweezers for threading the thread guides. If a looper thread breaks or runs out, just re-thread it. There is no need to follow a specific threading sequence.

Threading Position for Threading

1. Open the front cover.
2. Raise the presser foot to release all threads.
3. Set the threading lever from serging position to threading position (fig.A).
4. Rotate the machine handwheel slowly toward you until the tubes move to connecting position (fig.B).

Note: The Enlighten must be in the locked position when threading the loopers unless otherwise indicated.

Lower Loper

1. With the presser foot up and threading lever in the threading position (fig. A) .
2. Place the thread cone or spool on the far right front spool pin on the thread stand (fig.C page 11). Slip the thread into the telescopic antenna thread guide "1" directly above the spool, snap into the thread guide "2" at the top of the machine, through the slot on the front of the machine (fig. C page 11).
3. Pull 18 inches (45cm) of thread through guide "3". Insert the end of the thread into the threading port "L" about 1/2 inch (1.2cm) . Use tweezers if necessary, to insert the thread end more easily.
4. Push the threading button (fig. D page 11) . If the thread does not go through the lower looper eye with one push, push the threading button again until it does. *(page 11)
5. Clip the thread 4 inches (10cm) from the lower looper eye and leave it hanging loose.
6. Set the threading lever to serging position.

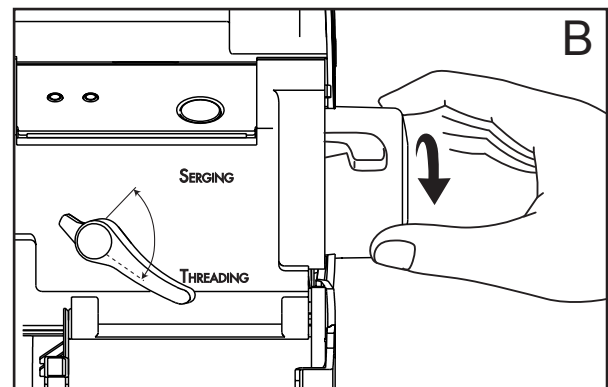
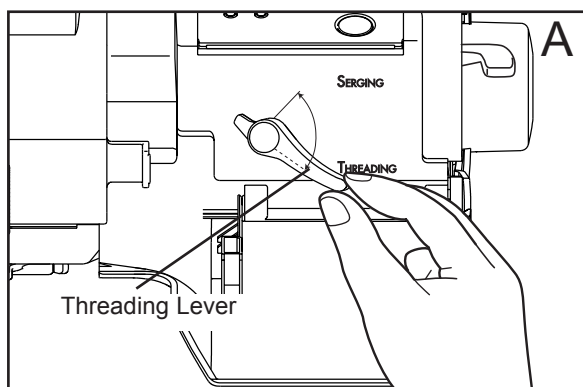

Upper Looper

1. With the presser foot in the up position, open the front cover and move the threading lever into the threading position (fig. A page 10).
2. Place the thread cone or spool on the second spool pin from the right. Slip the thread into the telescopic antenna thread guide "A" directly above the spool, snap into the thread guide "B" at the top of the front of the machine, through the slot on the front cover (fig. C).
3. Pull 18 inches (45cm) of thread through guide "C". Insert the end of the thread into the threading port "U", about 1/2 inch (1.2cm). Use tweezers, if necessary, to insert the thread end more easily (fig. D).
4. Push the threading button (fig. D). If the thread does not go through the upper looper eye with one push, press the looper threading button again until it does, and leave thread hanging loose.
5. Set the threading lever to serging position.

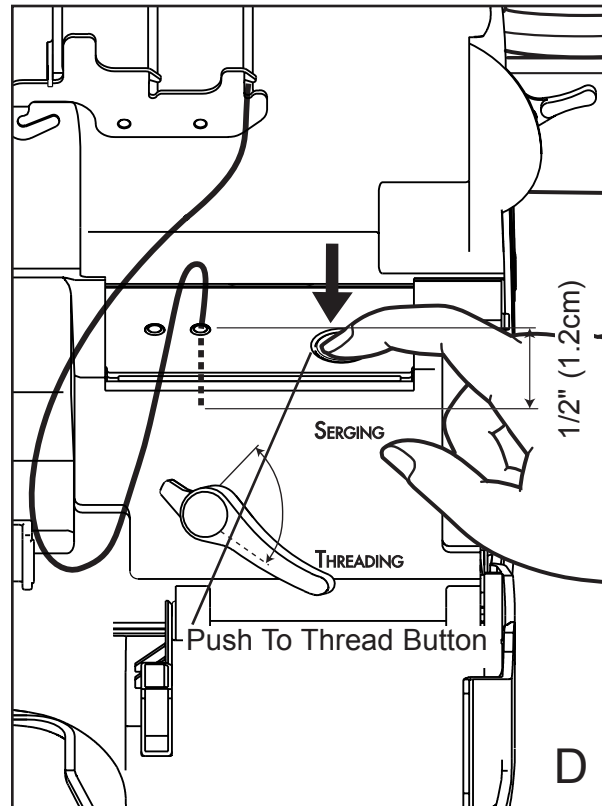
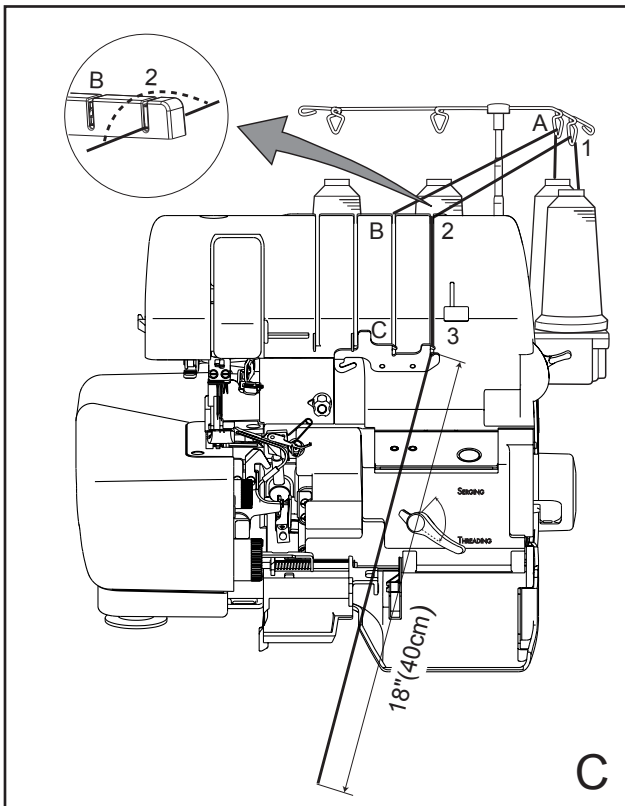

**Be sure at least 1/2" of thread is inserted into the threading port.*

Right Needle

1. With the presser foot up position and the machine engaged in the threading position (page 10, fig. A), set the needle threader selector on "R" to thread the right needle (page 13, fig. A).
Note: Be sure to push the needle threader selector all the way to "R".
2. Place the thread on the second spool pin from the left on the thread stand (illustrated below). Thread needle thread guides 1 and 2, through the groove on the front of the machine and through guides 3, 4, 5, 6 and 7. Pull a 6-inch (15 cm) length of thread through guide 7.
3. Lower the presser foot to engage the tensions.
4. Manually insert thread into the eye of the right needle or follow needle threader instructions on page 13.
5. Continue pulling the thread through the needle eye. Place the thread under the presser foot and to the left.

Note: The Enlighten must be in threading position when using the needle threader unless otherwise indicated. This is also a safety feature when threading the machine, as the machine cannot sew while in the threading position.

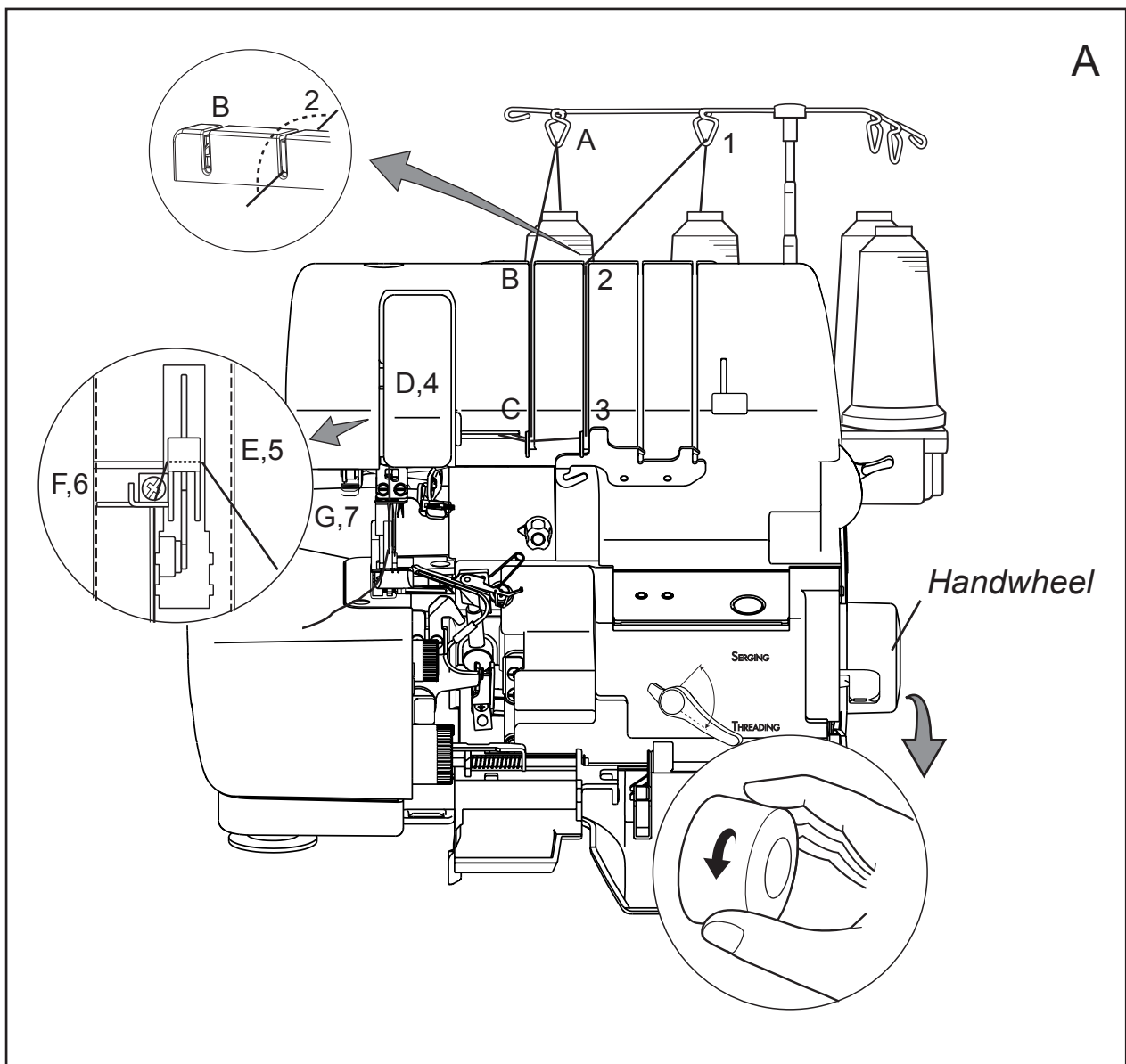

Left Needle

1. With the presser foot up and the machine engaged in the threading mode (page 10, fig. A), set the needle threader selector on "L" to thread the left needle (illustrated below).
Note: Be sure to push the needle threader selector all the way to "L".
2. Place the thread on the far left spool pin on the thread stand (illustration on page 12). Thread needle thread guides A and B, through the groove on the front of the machine and through guides C,D,E,F and G.
3. Lower the presser foot and thread the left needles as in steps 4 and 5, under "Right Needle".

Needle Threader

1. Set the needle threader selector on "R" (right needle) or "L" (left needle). (Fig.A)
2. Press the needle threader lever down (Fig. B) so that the hook goes into the eye of the needle. The hook will remain in the eye of the needle.
3. Hold the needle thread horizontally with both hands and position the thread into the threader hook guides on top of thread hook (illustration C for correct positioning).
4. Tap the needle threader lever down again. (Fig.D) The hook will pull the thread through the eye of the needle as it is released.
5. Carefully remove the loop of thread from the needle threader hook and place the thread under the presser foot and to the left.

Note: With the machine in the threading position, this sets the needle position for using the needle threader.

This is also a safety feature when threading the needles, as the machine cannot sew while in the threading position.

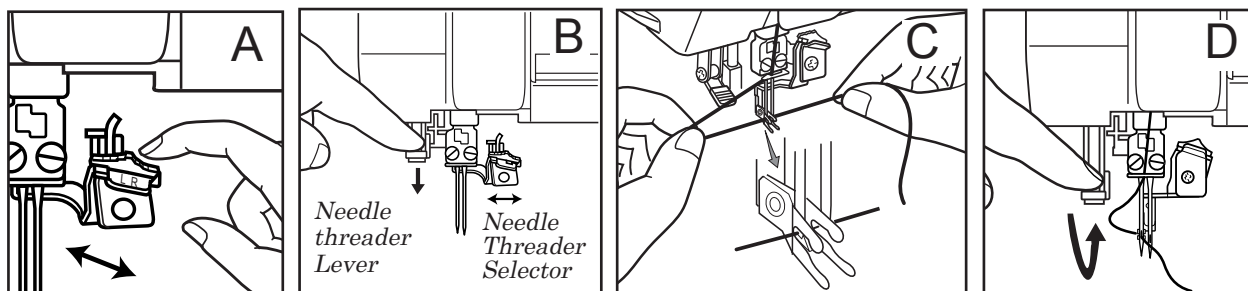

Looper Thread Fine-Tuning Knob

No adjustments are needed when sewing with most fabrics and threads on your Baby Lock EnlightenWave, but certain threads or fabrics may require minor fine-tuning of the looper delivery system to perfect your stitches. Increase or decrease the delivery of the looper threads with the upper and lower looper thread fine-tuning screw. With a screwdriver (found in accessory kit), turn the fine-tuning screw clockwise to tighten the looper threads equally. Turn the screw counter-clockwise to loosen the looper threads equally.

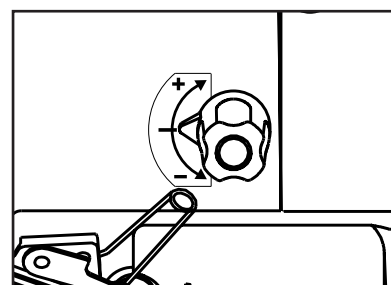

Ideal Stitch

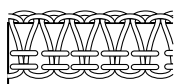

Standard Position

Looper threads are too loose.

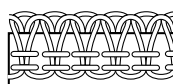

Tighten the screw (+)

Looper threads are too tight.

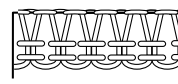

Loosen the screw (-)

Serging with Fabric

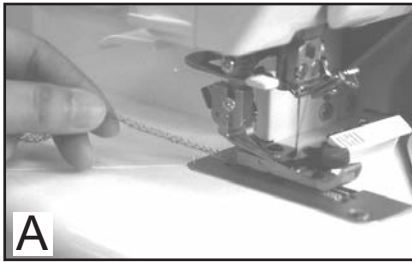

With the needle and looper threads under the foot and to the back, lower the presser foot. While holding the threads in your left hand, press down on the foot control gently to begin a thread chain before serging fabric (fig.A).

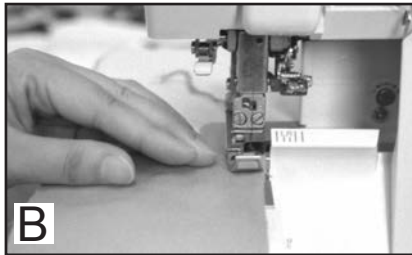

You can leave the presser foot down for most serging applications. Just place the fabric at the toe of the presser foot. As you step on the foot control, the feed dogs will begin moving the fabric toward the needle (fig.B). You need to raise and lower the foot only when working with thick, spongy or lofty fabrics, or when precise positioning is required.



Be careful not to push or pull the fabric. The Enlighten will feed it evenly without help. At the end of a seam, just sew off the fabric edge and continue serging to create 5" - 6" thread chain. Cut the thread chain with the thread cutter on the left side cover (fig.C).

Clearing the Stitch Width Fingers

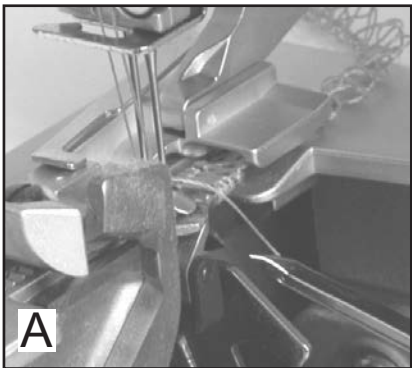

As you sew, you will discover that maneuvering the fabric is different from conventional sewing because the threads form around the stitch fingers (fig. A).

To clear the stitch fingers, simply raise the presser foot, which releases all threads. Turn the handwheel forward to raise the needle(s). Then pull the threads gently from behind the foot (fig. B). The stitches are now released from the fingers (fig. C).



Thread Delivery System

The Baby Lock Enlighten revolutionizes the way a serger works with its Thread Delivery System. You no longer have to manually adjust the tension settings for the type of stitch you are serging. Select the type of stitch you wish to serge, the Enlighten will automatically feed the correct amount of thread through the loopers and thread guides to form a perfect stitch every time.

Stitch Selector

The stitch selector controls the thread delivery system and is located on the right front side of the machine. To select a stitch setting, move the stitch selector lever to A, B, C, or D.

A - For Wide overlock stitches using the left (L) needle.

B - For balanced overlock stitches using the right (R) needle and 3-thread Wave stitch.

C - For narrow stitches with a short length and Rolled Wave Stitch.

D - For 3-Thread rolled hem stitch.

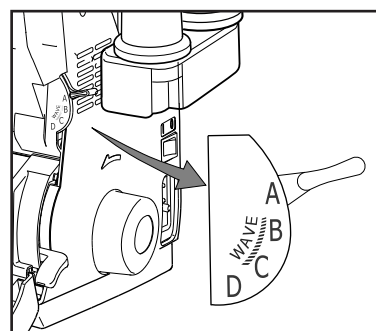

For best results, use setting B or C for WAVE stitching. See chart on last page for stitch selection settings.

Wave Selector

The Wave Selector lever shows "OVERLOCK" and "WAVE". Select "OVERLOCK" for overlock stitching. Select "WAVE" for wave stitching.

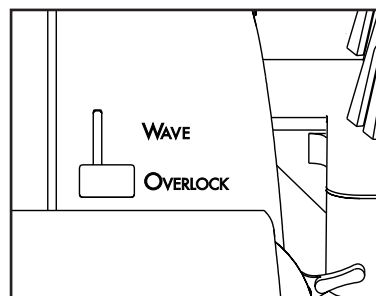

Re-threading Loopers

If a thread breaks, raise the presser foot and pull the broken thread out from under the foot. Open the front cover and engage the threading lever (page 10). Re-thread the machine above the threading port, leaving an 18-inch (45cm) thread tail. Thread the looper as usual then engage the threading lever to the serging position (page 10/11). Close the front cover and sew a test sample.

Note: When re-threading your Baby Lock Enlighten using the "Extraordin Air Threading" feature, make sure that the previous thread that was in the looper (tube) is completely removed. This will eliminate any chance of the previous thread obstructing the flow of the air when re-threading the machine.

Re-threading Needles

If a needle thread breaks, raise the presser foot, remove the broken thread and rethread the needle thread guides. Open the front cover, depress the machine lock button. Select the "R" or "L" for the needle being threaded. Use the needle threader for exact and easier threading. Refer to pages 12 or 13 for further information.

Stitch Length/Rolled Hem

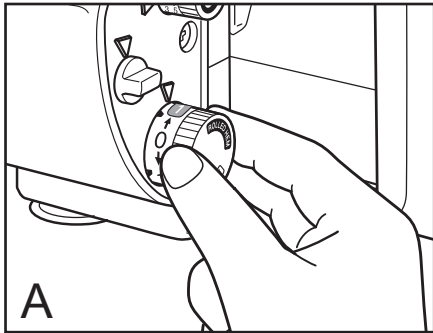

The stitch length / rolled hem adjusting dial is conveniently located just to the left of the front cover, near the base plate (fig. A). The dial shows two stitch-length ranges, from 0.75, for the shortest stitch, to 4 for the longest. As the dial indicates, one range is for standard sewing and one is for rolled edging or narrow seaming. Simply turn the dial aligning the desired setting with the indicator on the machine. A stitch length of 3mm, or about 10 stitches per inch is ideal for seaming and overedging most fabrics. For overedging or seaming very lightweight fabrics, you may prefer a shorter stitch length. When sewing heavier fabrics, you may choose to lengthen the stitch (fig. B).

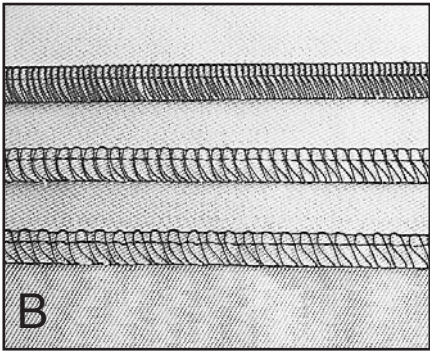

Note: 0.75mm is located between the 0 and 1 on both standard & rolled settings.

Stitch Width

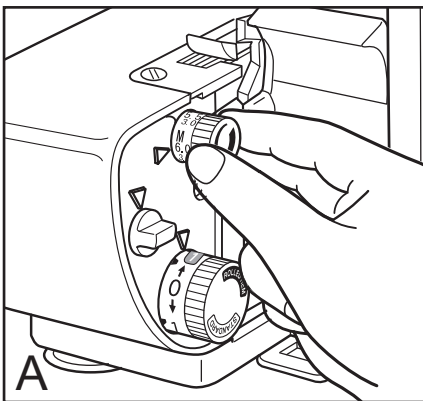

The stitch width adjusting dial is located above the stitch length dial (fig. A). The stitch width dial displays two sets of numbers, indicating two width ranges. The larger numbers at each end of the dial, 5.5 and 7.5mm, denote the stitch width dial when the left needle is in use. The smaller numbers, 3.0 and 5.0mm, apply when the right needle is in use.

Adjusting the stitch width moves the upper cutting blade. It also moves the stitch fingers further apart or closer together for complete fabric support with any stitch width.

The stitch width is variable by the placement of Right and Left needles and the stitch width dial positions. (Fig.B)

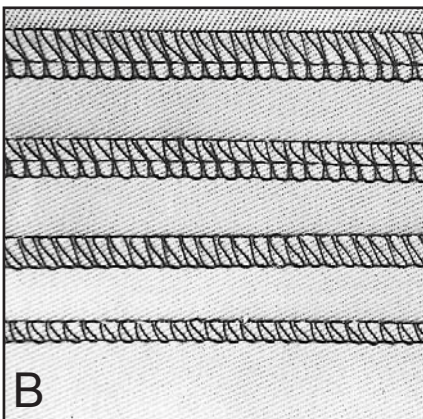

Differential Feed

Your Baby Lock serger is equipped with differential feed. The set of feed dogs work independently in order to ensure smooth sewing on all fabrics.

When the differential feed adjusting lever, located at the machine's right, front edge is set on "N" for normal feeding, the feed dogs move the same distance. This is the setting to use for most fabrics and applications.

When the dial is set above "N" (fig. B), the front feed dog will feed more fabrics than the back. This is because the front feed dog moves at a greater distance than the back feed dogs. As a result, the fabric becomes compressed or eased, as the diagram on the front cover indicates. This action can eliminate wavy seams in stretchy fabrics or those cut on the bias grain (fig. A).

At the maximum setting of 2.0 (fig. C), the differential feed can gather a lightweight fabric to nearly double fullness (fig. D). The front feed dog is actually feeding in twice as much fabric as the back feed dog is feeding out. To maximize the gathering effects, use the longest stitch length setting. Fabric weight will affect the gathering. Test stitch for desired results.

When the differential feed lever is set below "N" (fig. E), the front feed dog moves less distance than the back feed dog. This adjustment stretches the fabric slightly as it is sewn pulling it taut as it enters the needle. The lower settings prevent puckers on lightweight fabric (fig. F), add more stretch to swim wear, active wear, and can be used to create a lettuce edge (page 36).

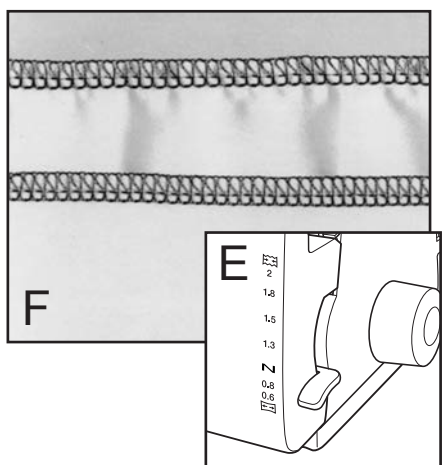
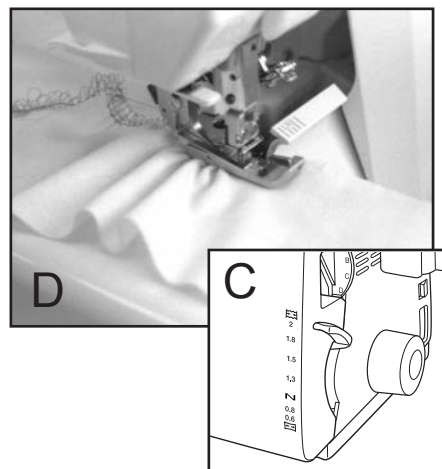
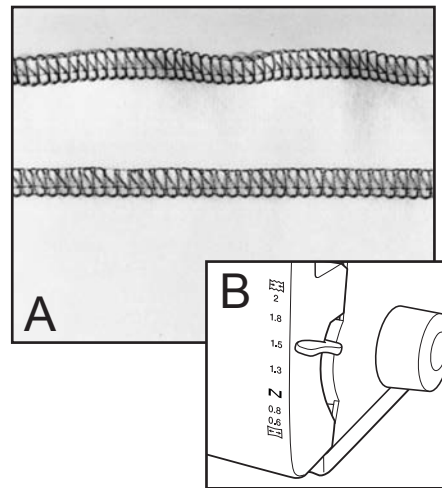

Disengaging the Upper Cutting Blade

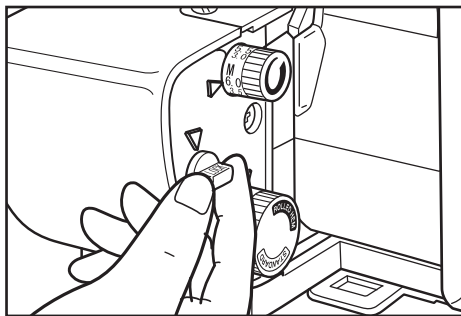

When no trimming is desired, as when stitching on a fold, flip the cutting blade lock switch clockwise to the LOCK position. The cutting blade no longer moves up and down, but remains in its lowered position. To re-engage the cutting blade, turn the cutting blade lock switch half of a turn counter-clockwise. The blade will start moving automatically when you start sewing.

Presser Foot Pressure Adjustment

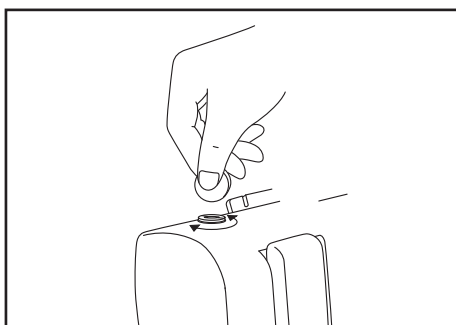

The presser foot pressure has been preset at the factory and rarely needs adjustment. You may find it necessary, however, to decrease the pressure for thick fabrics or increase pressure for thin fabrics to feed more smoothly under the foot. Use a coin to turn the screw on top of the machine.

To increase pressure, turn the pressure adjusting screw clockwise.

To decrease pressure, turn the screw counterclockwise.

Snap-On Presser Foot

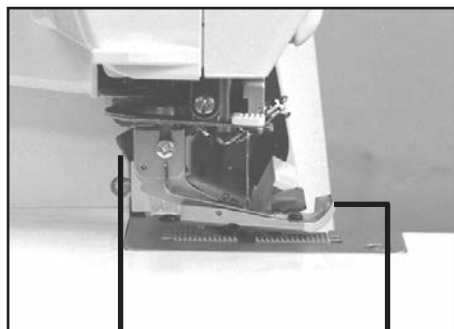

*Presser Foot
Release Button*

*Seam Line
Guides*

The Enlighten has the convenience of a snap-on presser foot.

To Release:

1. Raise the presser foot lever.
2. Lower the cutting blade.
3. Raise the needles to the highest position.
4. Push the presser foot release lever located at the back of the presser foot holder.
5. Carefully turn the presser foot clockwise 90 degrees.
6. Slide the presser foot to the rear to remove.

To Replace:

1. Raise the presser foot lever.
2. Lower the cutting blade.
3. Raise the needles to the highest position.
4. Slide the foot from the left to right.
5. Align the bar of the foot with the groove in the holder.
6. Lower the presser foot lever to snap into place.

The presser foot that comes with the Enlighten has a tape sewing slot. Insert the tape or ribbon, into the slot in the front of the foot, then under the sole of the foot. (page 41 for more instruction)

The raised markings on the toe of the foot are seam line guides. They indicate the needle positions to help guide your fabric for accurate seaming.

4-Thread Overlock

With the Enlighten Thread Delivery System, the upper and lower looper threads lock together evenly over the cut fabric edge(s) to form a flat, non-rolling pattern of overlocking stitches on both sides of the fabric.

The left needle thread interlocks with both looper threads at the stitching line to create the seam. The right needle thread, visible on the top side of the stitch, interlocks with both the loopers to add durability. The thread, that resembles a zigzag on the upper side of the fabric, is from the upper looper. The thread, that resembles a zig zag on the lower side of the fabric, is from the lower looper.

Move the stitch selector lever to "A".

For the perfect 4-thread overlock stitch, follow the suggested settings and threading diagram below.

NEEDLES left & right	LENGTH 2.5-3.5	WIDTH 6.0-7.5	STITCH SELECTOR A	WAVE SELECTOR OVERLOCK
-------------------------	-------------------	------------------	-------------------------	------------------------------

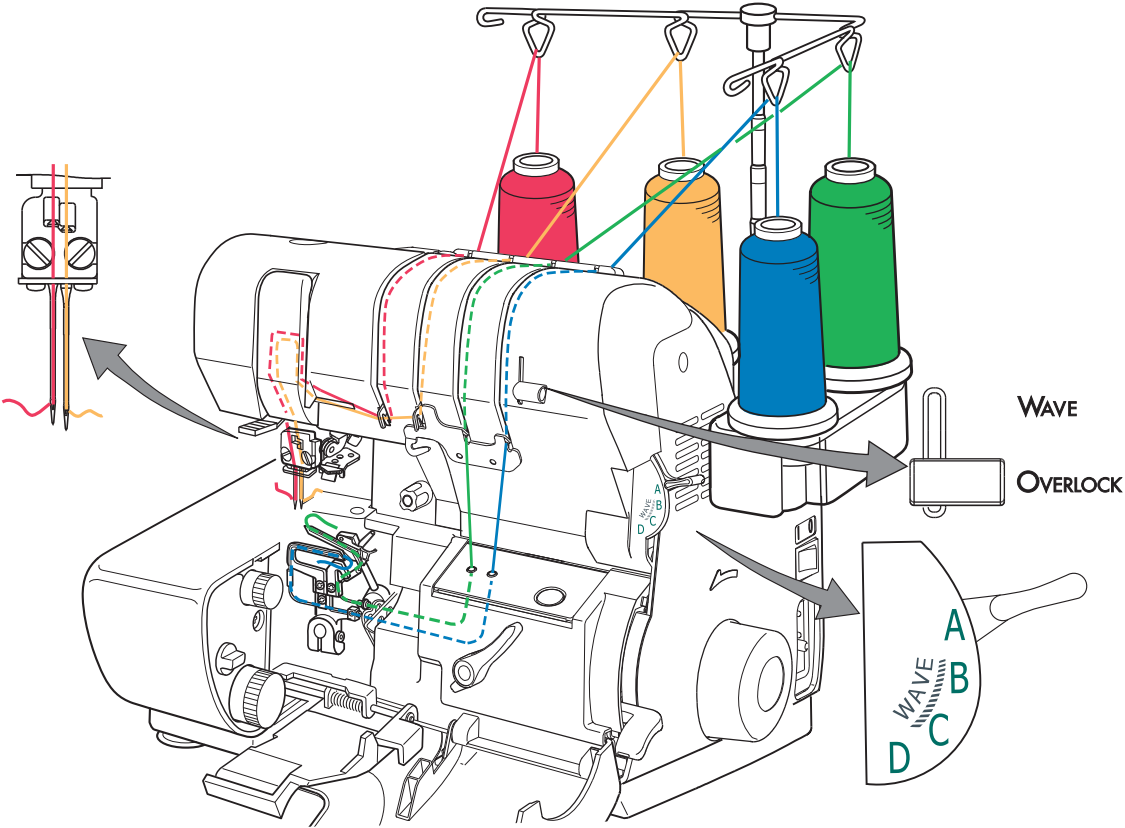

3-Thread Overlock-Wide

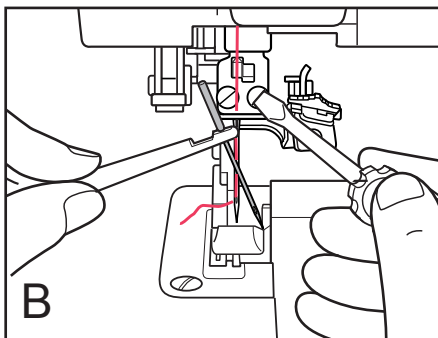
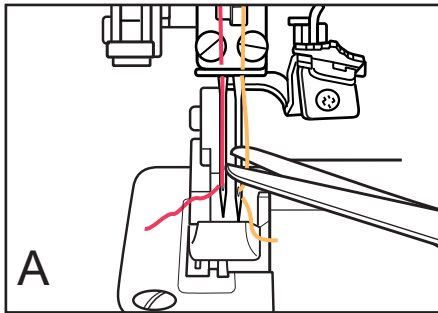

The 3-thread overlock wide stitch is perfect for edge-finishing most woven fabrics and for seaming knits that do not require the extra durability that a fourth thread provides.

It's easy to convert your Enlighten to serge with 3 threads by simply eliminating either needle.

To convert your serger to a 3-thread overlock wide (7.5mm), cut the right needle thread just above the needle eye (fig. A). Remove the right needle and right needle thread completely from the machine. Re-tighten the needle clamp screw slightly to prevent the screw from working out (fig. B).

Move the stitch selector lever to "A".

For left needle, 3-thread overlock-wide, follow the suggested settings and the threading diagram below.

NEEDLES	LENGTH	WIDTH	STITCH SELECTOR	WAVE SELECTOR
left	2-3	7.5	A	OVERLOCK

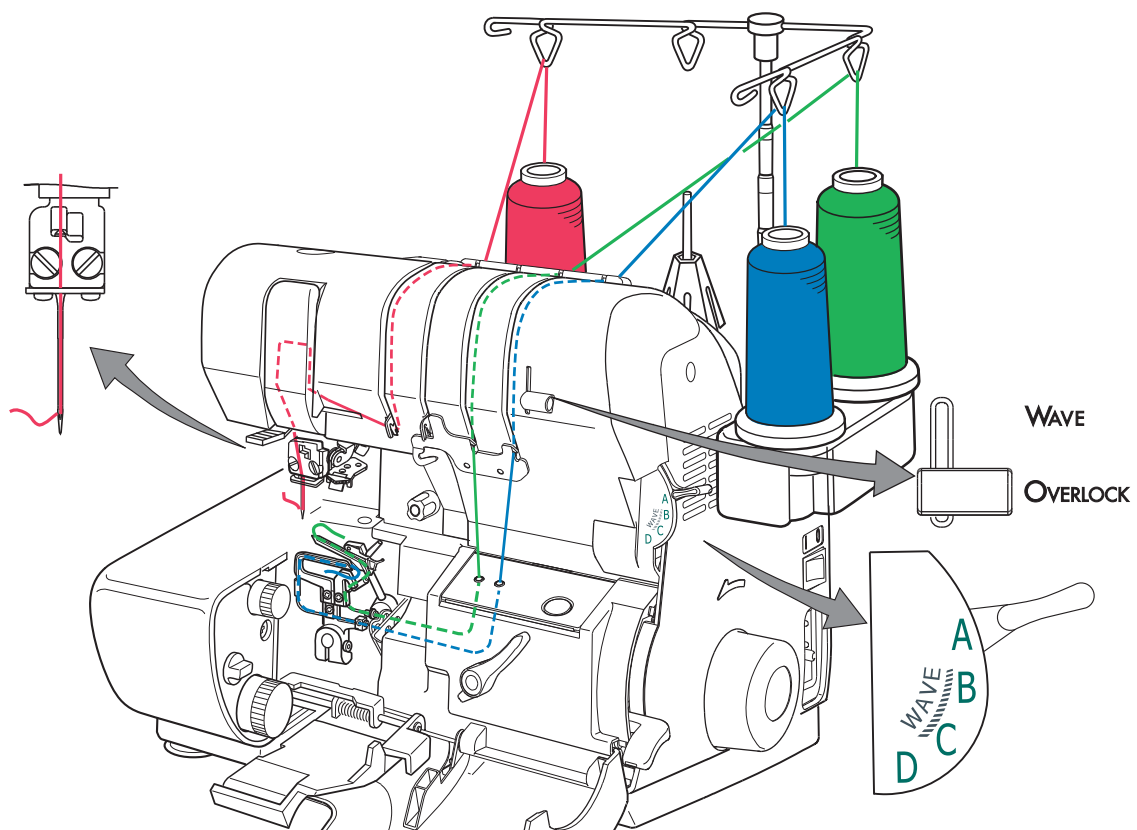

3-Thread Overlock-Narrow

It's easy to convert your Enlighten to serge a narrow seam with 3 threads by simply eliminating the left needle.

To convert to narrow 3-thread overlock (3.0-3.5mm), cut the left needle thread (fig. A). Remove the left needle and left needle thread completely from the machine.

Tighten the needle clamp screw slightly to prevent the screw from working out (fig. B).

Confirm needle is in the right needle clamp position and secure the needle clamp screw.

Move the stitch selector lever to "B".

For the right needle, 3-thread overlock sewing, follow the suggested settings and the threading diagram below.

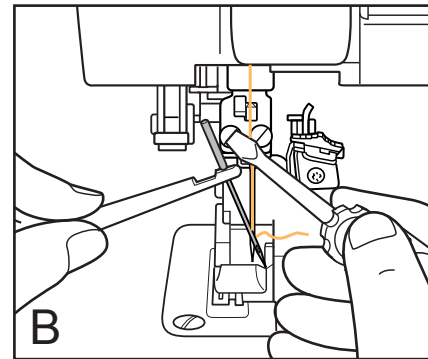
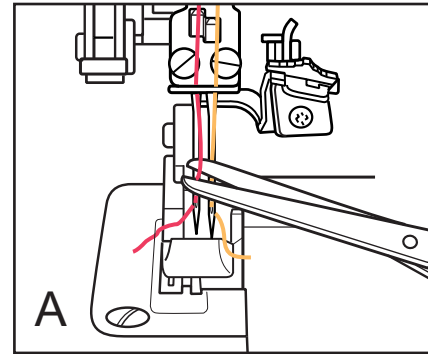

NEEDLES right	LENGTH 2.5-3.5	WIDTH 3.0-3.5	STITCH SELECTOR B	WAVE SELECTOR OVERLOCK
------------------	-------------------	------------------	-------------------------	------------------------------

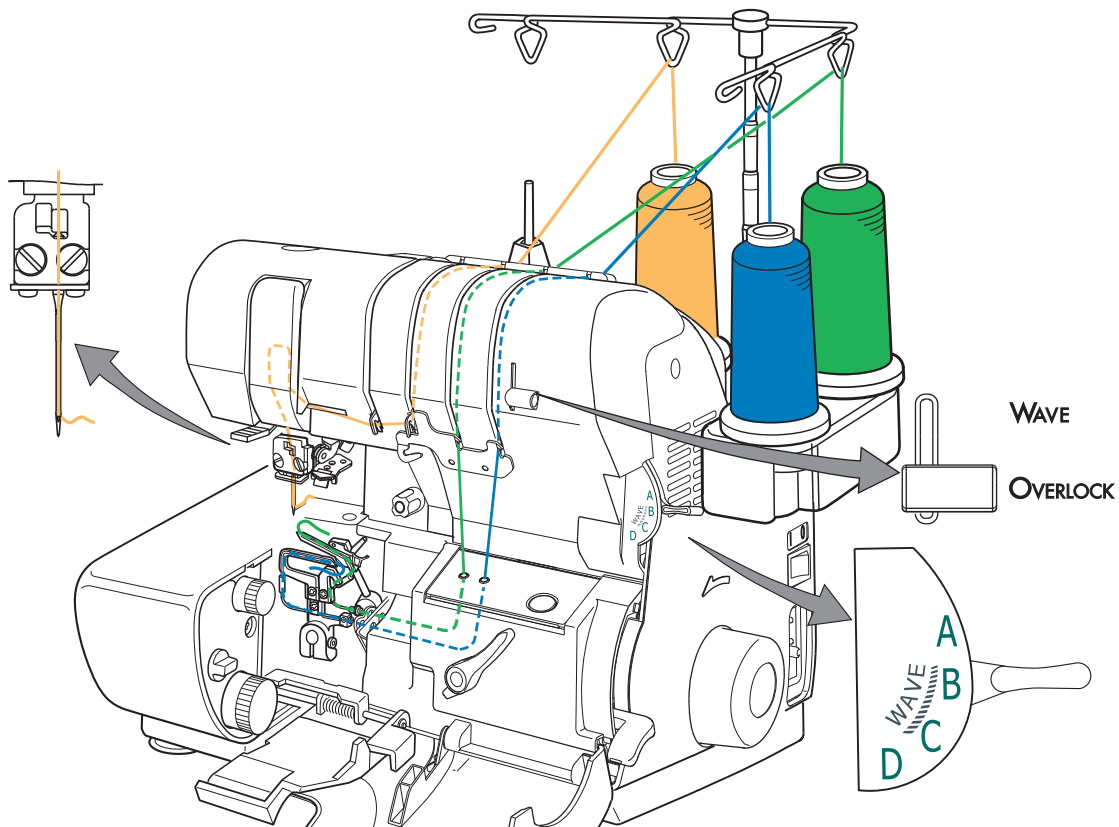

3-Thread Overlock-Narrow Hem

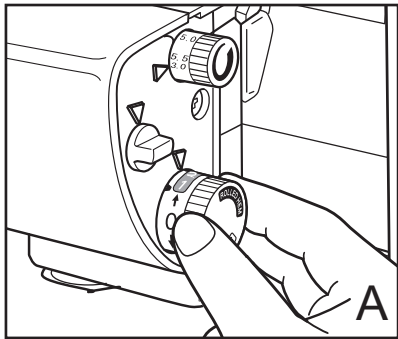

Narrow Hemming is an attractive finish for light to medium to heavy weight fabrics.

Remove the left needle and left needle thread completely from the machine. Clear the stitch fingers. Turn the stitch length adjusting dial counter-clockwise to the rolled hem range. Set the length at "0.75 to 4.0" (fig. A) and the stitch width at 3.0 for a smooth decorative finish (fig. B).

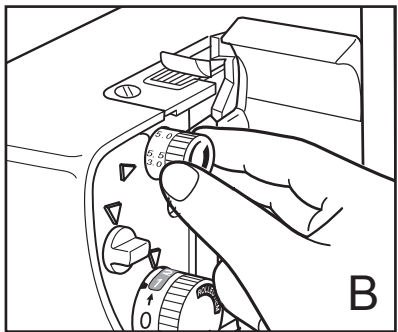

Move the stitch selector lever to "C".

For the right needle 3-thread narrow hemming, follow the suggested settings and the threading diagram below.

NEEDLES right	LENGTH 0.75-4.0R	WIDTH 3.0	STITCH SELECTOR C	WAVE SELECTOR OVERLOCK
------------------	---------------------	--------------	-------------------------	------------------------------

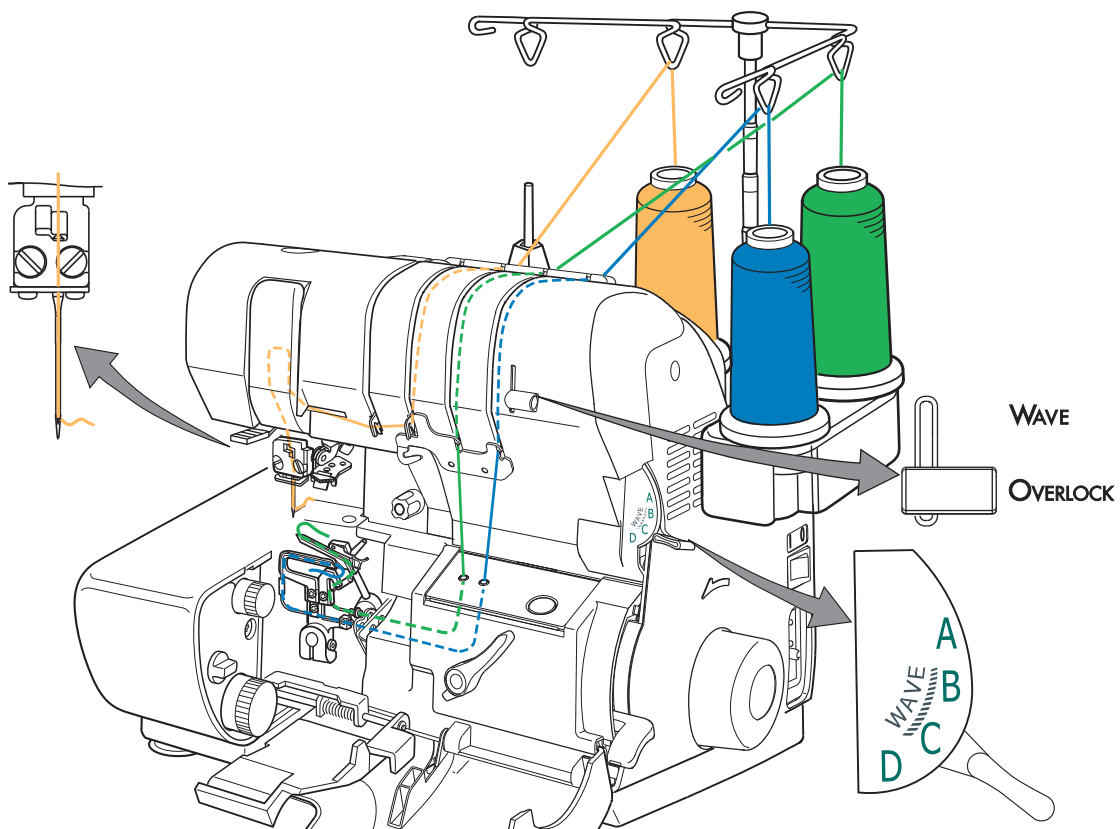

Rolled Edging

The rolled edge setting is used to achieve the narrowest stitch possible (1.5mm) on your Baby Lock serger. The stitch is suitable for seaming sheer and lightweight fabrics and for edging and hemming lightweight fabrics.

3-Thread Rolled Edge

With the stitch selector set on "D", a narrow hem will become a rolled edge. The fabric edge rolls around the stitch finger. The upper looper wraps the fabric edge while the lower looper thread is nearly invisible on the back side of the stitch formation.

Remove the left needle and thread. Clear the stitch fingers. Turn the stitch length adjusting dial counter-clockwise into the rolled hem range at 0.75-4.0R setting (fig. A). Set the stitch width dial to 3.5 "M" (fig. B).

For a 3-thread rolled edge, move the stitch selector lever to "D" and follow the suggested settings and threading diagram below.

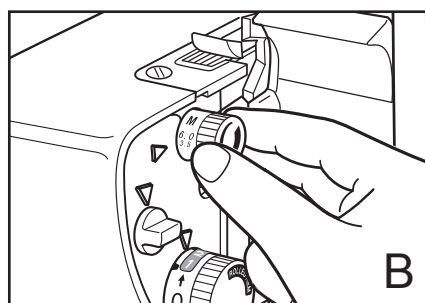
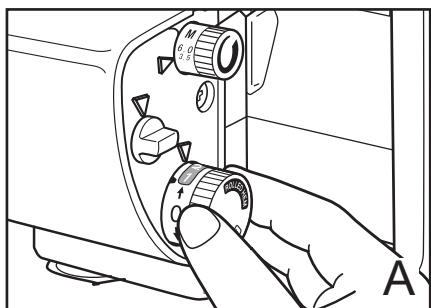

NEEDLES right	LENGTH 0.75-4.0R	WIDTH 3.5	STITCH SELECTOR D	WAVE SELECTOR OVERLOCK
------------------	---------------------	--------------	-------------------------	------------------------------

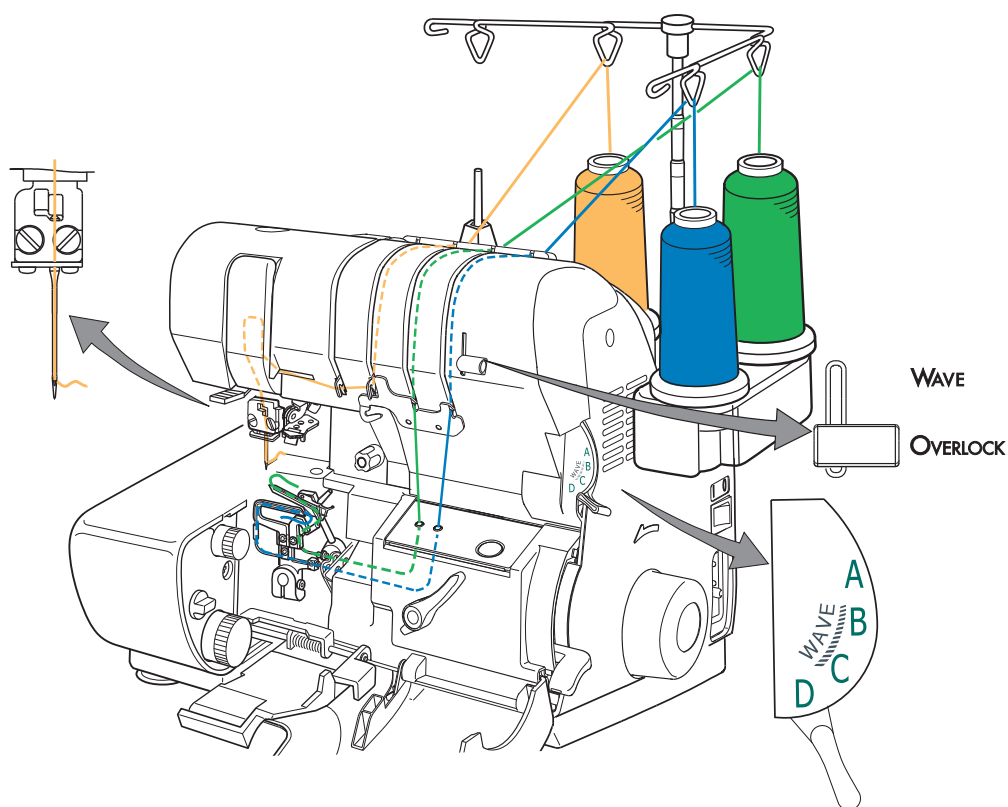

3-Thread Flatlock

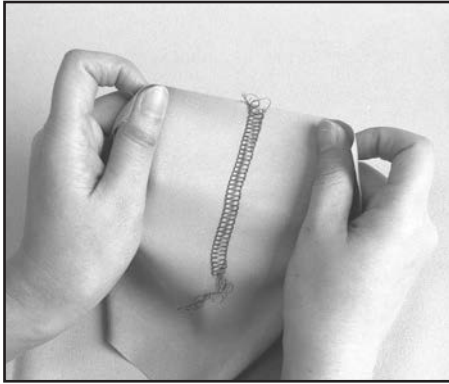

Flatlock seams are most suited to fabrics which do not ravel such as interlock knits, tricot, sweatshirt fleece and synthetic suede. The needle thread is carried below the fabric and to the cut edge of the fabric. The lower looper thread rides along the cut edge of the fabric for stability. The edges pull open and flatten within the stitch for a non-bulky join. Be sure to sew a test sample first to determine whether the stitch will have the strength to hold the seam without the fabric pulling away.

Move the stitch selector lever to "D".

For the right needle 3-thread flatlock, follow the suggested settings and the threading diagram below.

NEEDLES	LENGTH	WIDTH	STITCH SELECTOR	WAVE SELECTOR
right	2-3	3.0-5.0	D	OVERLOCK

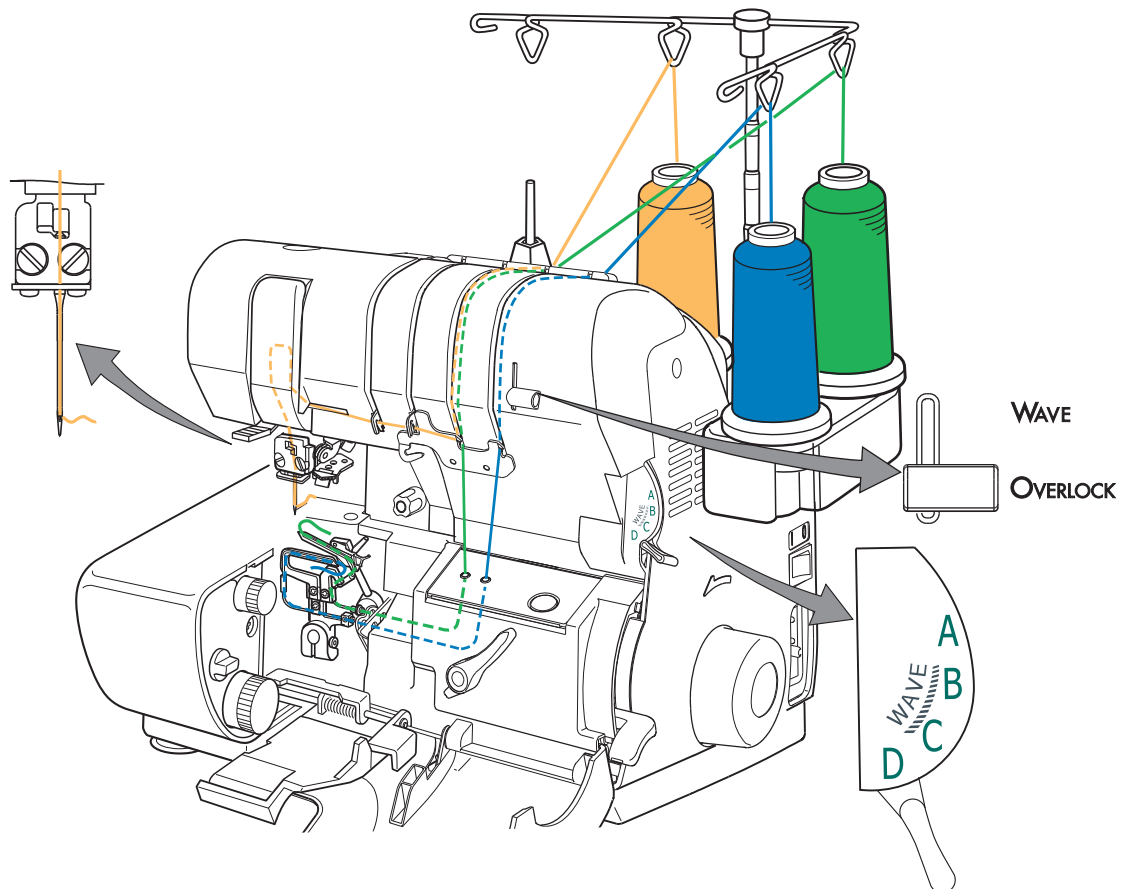

2-Thread Overlock

The 2-thread function provides an economical and less bulky means of overedging all fabrics. The standard 2-thread overlock is the same as a 2-thread flatlock stitch.

When sewn with specialty threads, 2-thread sewing makes decorative seams and edges for activewear, children's clothing, ruffles, and hemlines.

Converting from 3-Thread Overlock to 2-Thread Overlock

Left or right needle positions can be used for 2-thread serging.

See machine threading illustrations on (page 26/27.)

1. Open the front cover and blade cover. Cut the upper looper thread just above the threading port (fig.A).
2. Raise the presser foot and remove the upper looper thread and needle thread from the machine.
3. Rotate the handwheel forward to bring the upper looper into position to attach the subsidiary looper. Rotate the subsidiary looper up and to the left (fig.B) then slip the end into the upper looper eye. (fig.C)
4. Place the left needle thread on the far left spool pin (or right needle thread on second from left spool pin) and bring the thread through the telescopic thread guide directly above the spool pin of thread. Bring the thread through the top thread guide that is normally used for the upper looper (3rd from left), and down the front. Then take the thread to the left and thread the machine as you would for the needles in their normal position. (illustration on page 26/ 27 for correct threading.)
5. Using the needle threader, thread the eye of left or right needle. (page 13 for threading of needles.)
6. Place the needle thread and looper thread under the presser foot and to the back.
7. Close the cutting blade cover and front cover.
8. The needle and lower looper threads should overcast evenly on the cut edge of the fabric.

Note: The blade cover has been removed in illustrations B and C for a clear view.

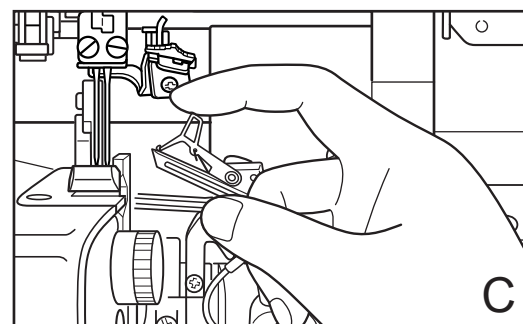
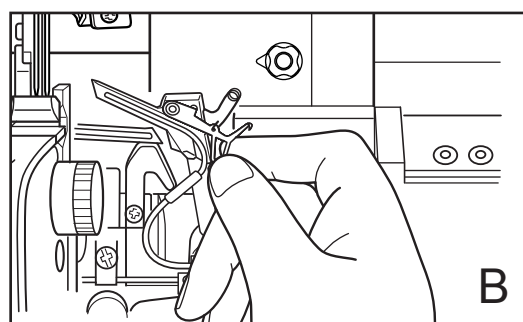
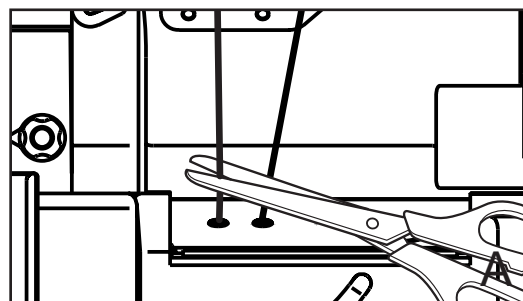

2-Thread Flatlock - Wide

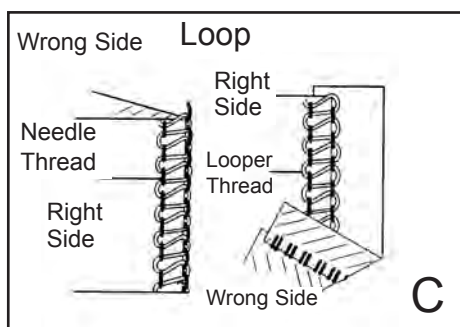
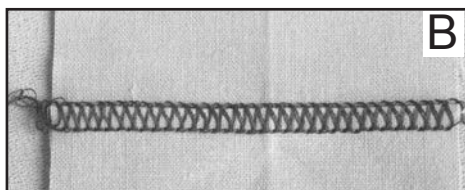
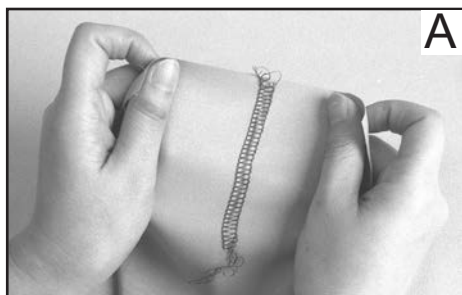

Sew 2-thread flatlock seams in the same way as 3-thread flatlock seams, then pull the two fabric layers apart until the seam lies flat (fig. A). Because the threads show on the outside as well as the inside of the garment or project, the 2-thread flatlock seam is often considered a decorative application (fig. B). Be sure to sew a test sample first to determine whether the stitch will have the strength to hold the seam without the fabric pulling away.

For 2-thread flatlock - wide

1. Engage the threading lever in the threading position.
2. Place the needle thread on far left spool pin.
3. Thread needle thread through the upper looper thread guide on top of the machine, then go down the thread path in the front of the machine. Go left with the needle thread at the hook on front of the machine. Then take the needle thread through the normal needle thread paths. (illustration below). Thread the left needle for a wide flatlock.
4. Engage the subsidiary looper following step 3 on page 25.
5. Thread the lower looper as shown in the illustration below.
6. Engage the threading lever in the serging position.

If you want the "overlock stitching" to show on the right side of the fabric, place wrong sides together and sew. (Fig. C)

For a 2-thread wide flatlock, follow the suggested settings and threading illustration below.

Note: If the fabric does not pull completely flat under the stitches, guide the fabric fold to the left so that the loops hang slightly off the fold as they are being stitched.

NEEDLES	LENGTH	WIDTH	STITCH SELECTOR	WAVE SELECTOR
left	2-2.5	7.5	A	OVERLOCK

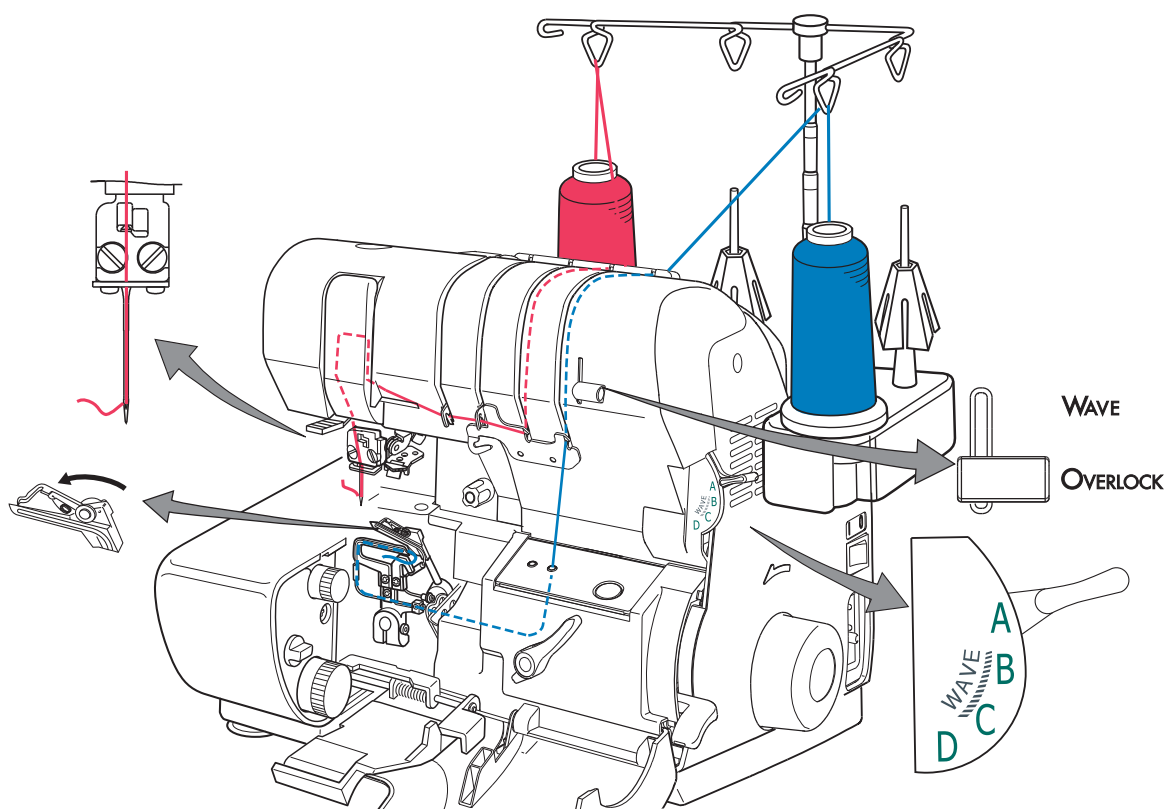

2-Thread Flatlock - Narrow

Sew a 2-thread flatlock seam then pull the two fabric layers apart until the seam lies flat (fig. A).

Because the threads show on the outside as well as the inside of the garment or project, the flatlock seam is often considered a decorative application (fig. B).

For 2-thread flatlock - narrow

1. Engage the threading lever in the threading position.
2. Place needle thread on right needle spool pin.
3. Thread needle thread through the upper looper thread guide on top of the machine, then go down the thread path in the front of the machine. Go left with the needle thread at the hook on front of the machine. Then take the needle thread through the normal needle thread paths. (illustration below). Thread the right needle for a narrow flatlock.
4. Engage the subsidiary looper following step 3 on page 25.
5. Thread the lower looper as shown in the illustration below.
6. Engage the threading lever in the serging position.

If you want the "overlock stitching" to show on the right side of the fabric, place wrong sides together and sew (Fig. C).

To produce the "Ladder" (needle thread) on the outside, place the fabric right sides together (fig. D).

For a 2-thread narrow flatlock, follow the suggested settings and threading illustration below.

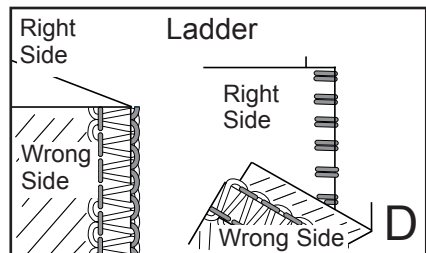
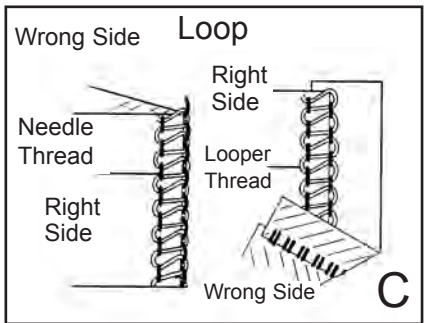
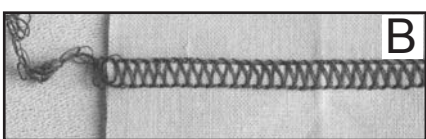

NEEDLES right	LENGTH 3-3.5	WIDTH 3.5	STITCH SELECTOR B	WAVE SELECTOR OVERLOCK
------------------	-----------------	--------------	-------------------------	------------------------------

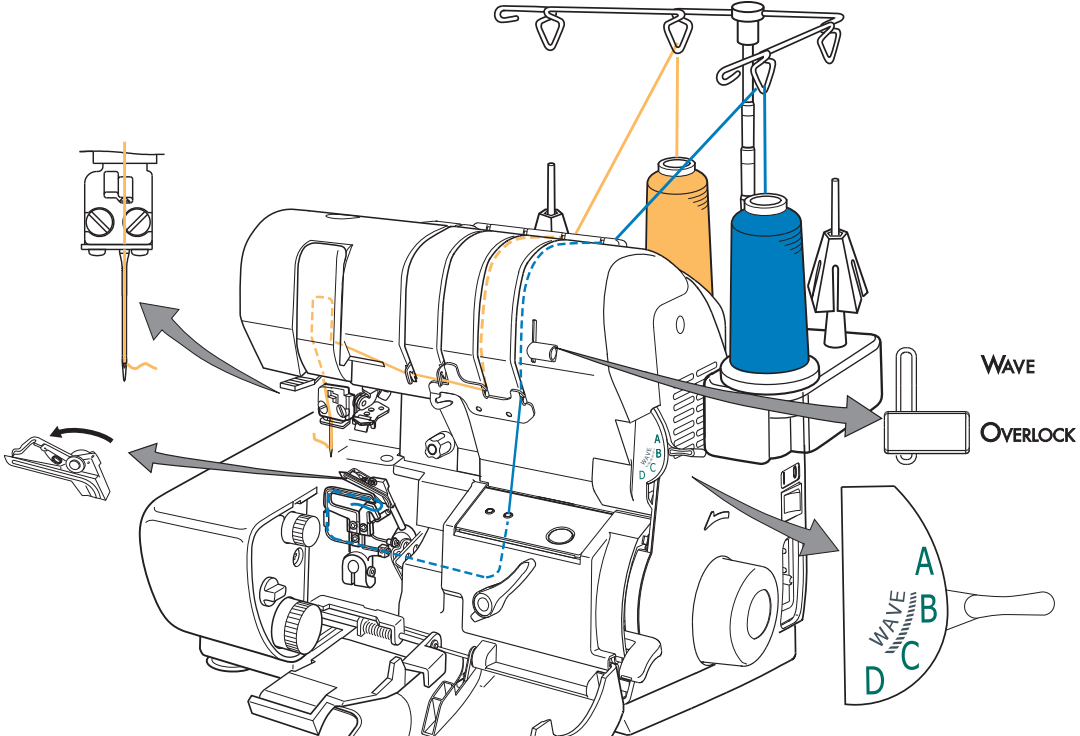

Flatlock "Topstitching"

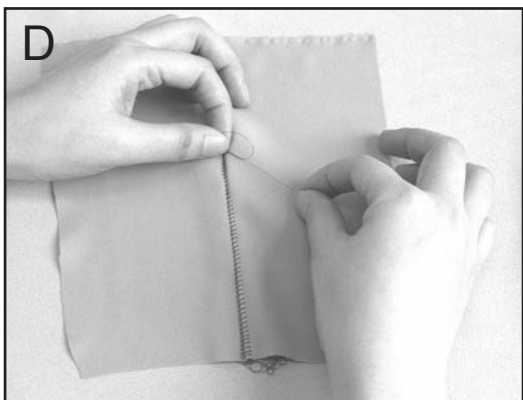
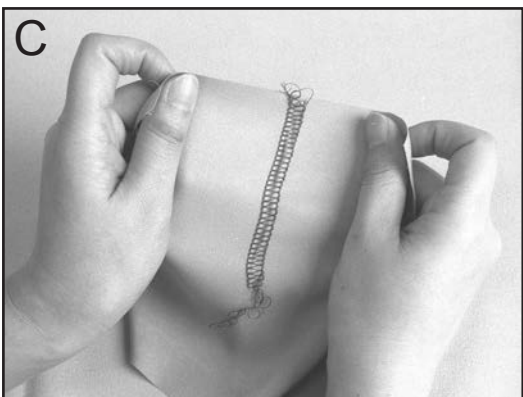
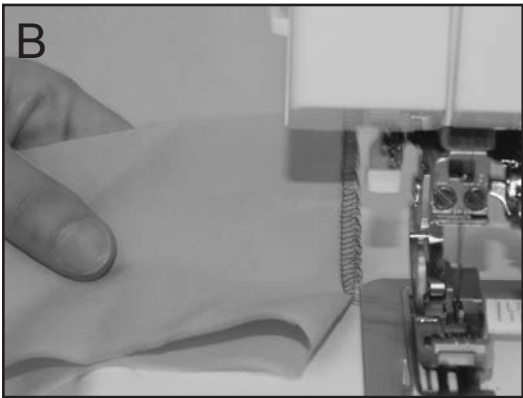
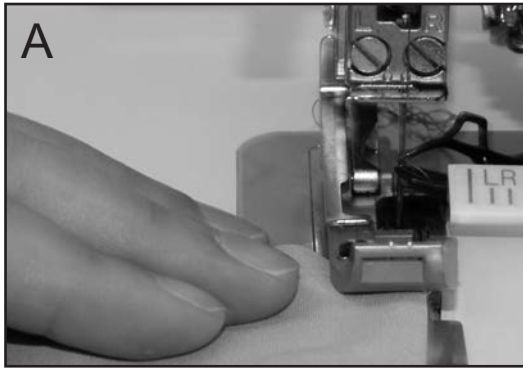

The flatlock stitch need not be limited at seamlines.

When sewn on a fold, flatlocking can create attractive decorative effects within the body of a garment or project. Either follow placement lines on your pattern or design your own special effects by stitching the fabric before laying out pattern pieces.

1. Set the machine for 2-thread flatlock - wide.
2. Turn the cutting blade lock switch clockwise to disengage the upper cutting blade.
3. Set the stitch length to desired setting appropriate for the thickness of your decorative thread.
4. Fold the fabric (right side or wrong side out, depending on the loop (page 26) or ladder (page 31) stitch you want to show) along stitch placement lines.
5. Position the fabric under the presser foot, aligning the fold of the fabric 1/8 inch (3.5mm) to the left of the upper cutting blade (fig A).
6. Stitch to the desired ending point.
7. Clear the stitch fingers and chain off the fabric (fig B).
8. Clip threads, leaving a 3-4 inch (7.5-10cm) chain.
9. Gently pull the fabric to flatten the stitches (fig C).
10. Separate the chain threads and thread them through a hand sewing needle and pull them to the fabric back side. If necessary, tie a knot to secure the threads (fig D).

Note: If the fabric does not pull completely flat under the stitches, guide the fabric fold to the left so that the loops hang slightly off the fold as they are being stitched.

Blind Hemming

Your Baby Lock Enlighten can create a sturdy, nearly invisible blindhem.

1. Set the machine for 2-Thread Overlock-Narrow with the right needle threaded. Set the stitch width at 5.0 and the stitch length at 4.0 in the standard range.
2. Fold up the hemline and press it in place. Then fold the hem allowance back against the fabric right side to create a fold about 1/4 " from the top edge of the hem as shown (fig. A).
3. Align the fold under the presser foot and stitch, allowing the needle to catch only a thread or two of the soft fold (fig. B). The blade will trim the top edge of the hem and the loopers will overcast the edge for a clean finish (fig. B).
4. Open the fold and press flat (fig. C).

Note: An optional blindhem foot for consistent guiding is available through your Baby Lock retailer (fig. D).

Page 7 Optional Accessories listing for part number.

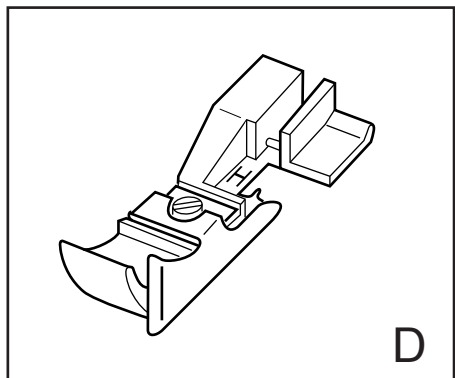
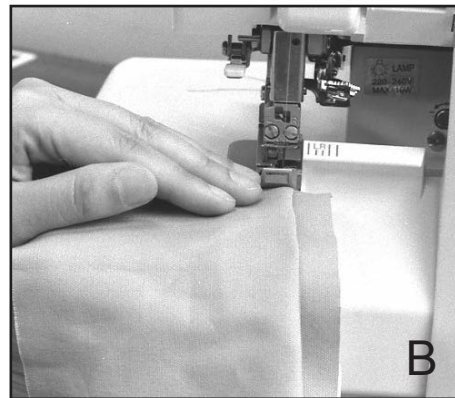

Blanket Stitch - Decorative Stitch

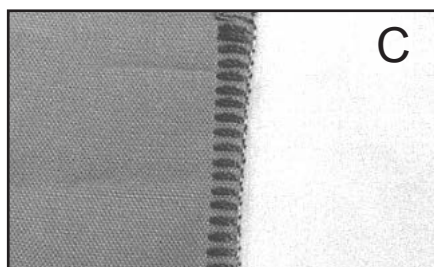
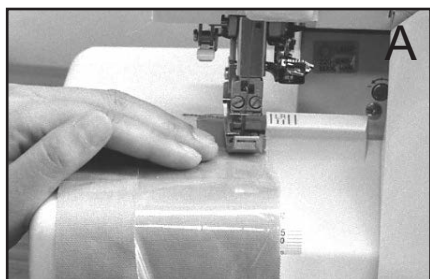

Set up the machine for 2-thread flatlock-wide but the needle threading path is different for this technique.

1. Insert a size 90 top stitch needle in left overlock needle position.
2. Engage the threading lever in the threading position.
3. Place a heavy decorative thread that will be used in the needle on far left spool pin and thread the needle thread through upper looper thread path (below illustration).
4. Engage the threading lever in the serging position, pull the thread out the upper looper tube and continue to thread the needle as illustrated.
5. Thread Maxilock thread in the lower looper.
6. Swing the subsidiary looper into place on the upper looper.
7. Place water-soluble stabilizer on top of the fabric, along the edge.
8. Stitch along the edge of the fabric. (Fig. A)
9. When finished stitching, pull the water-soluble stabilizer to the right of the fabric (fig. B). This will pull the stitching to the edge and will look like a blanket stitch (fig. C).

For a blanket decorative stitch, follow the suggested settings and threading illustration below.

NEEDLES left size 90 Top Stitch Needle	LENGTH 4.0	WIDTH 7.5	STITCH SELECTOR A	WAVE SELECTOR OVERLOCK
---	---------------	--------------	-------------------------	------------------------------

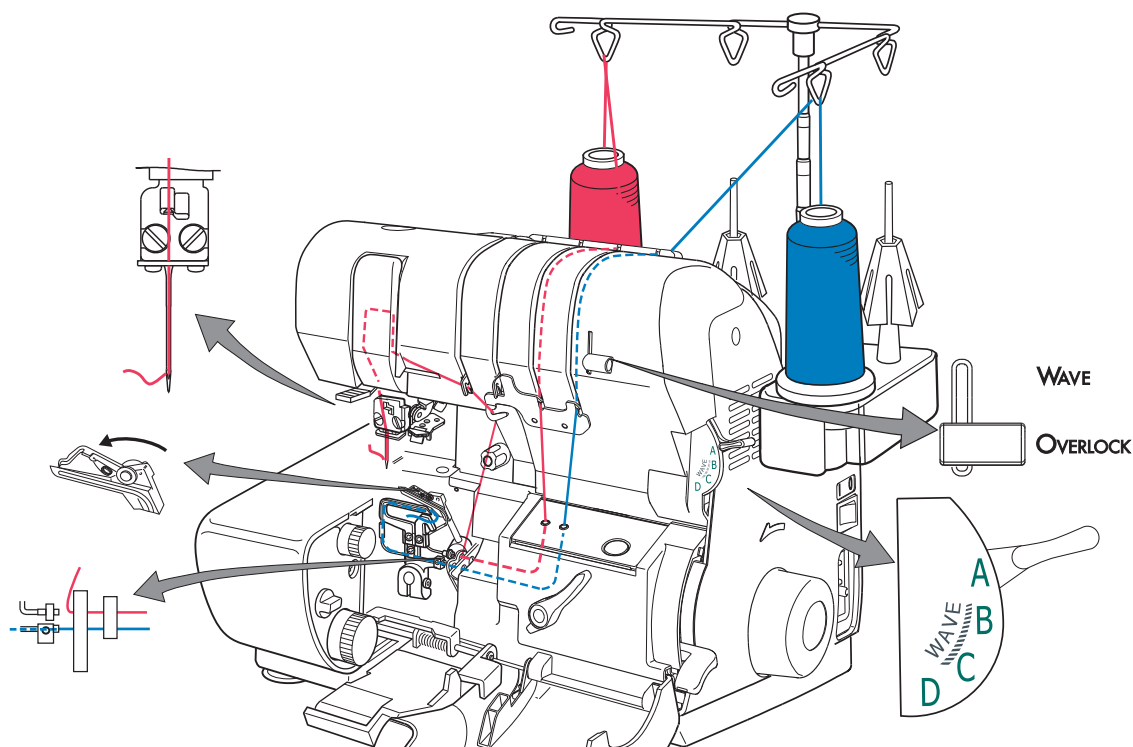

Ladder Stitch - Decorative Stitch

Note: The threading path for the needle thread is different in this technique. Please refer to the Quick Reference Threading Guide or illustration below.

1. Insert a size 90 top stitch needle in left overlock needle position.
2. Engage the threading lever in the threading position.
3. Place a heavy decorative thread that will be used in the right needle on far left spool pin and thread the needle thread through upper looper thread path (below illustration).
4. Engage the threading lever in the serging position, pull the thread out the upper looper tube and continue to thread the needle as illustrated.
5. Thread Maxilock thread in the lower looper.
6. Swing the subsidiary looper into place on the upper looper.
7. Place the fabric pieces right sides together for the decorative ladder to be on the right side of the fabric. (This can also be done on the fold as well.)
8. Sew the fabric together and gently pull open, revealing the decorative ladder stitching on the right side of the fabric.

For a decorative ladder stitch, follow the suggested settings and threading illustration below.

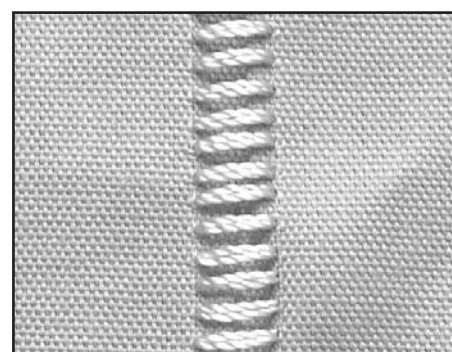
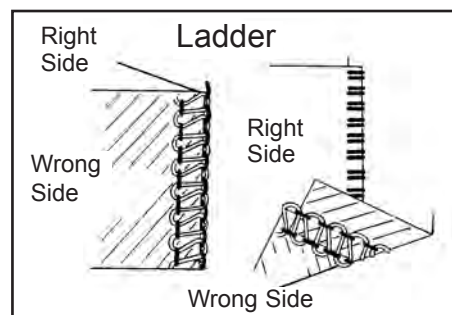

NEEDLES	LENGTH	WIDTH	STITCH SELECTOR	WAVE SELECTOR
left size 90 Top Stitch Needle	4.0	7.5	A	OVERLOCK

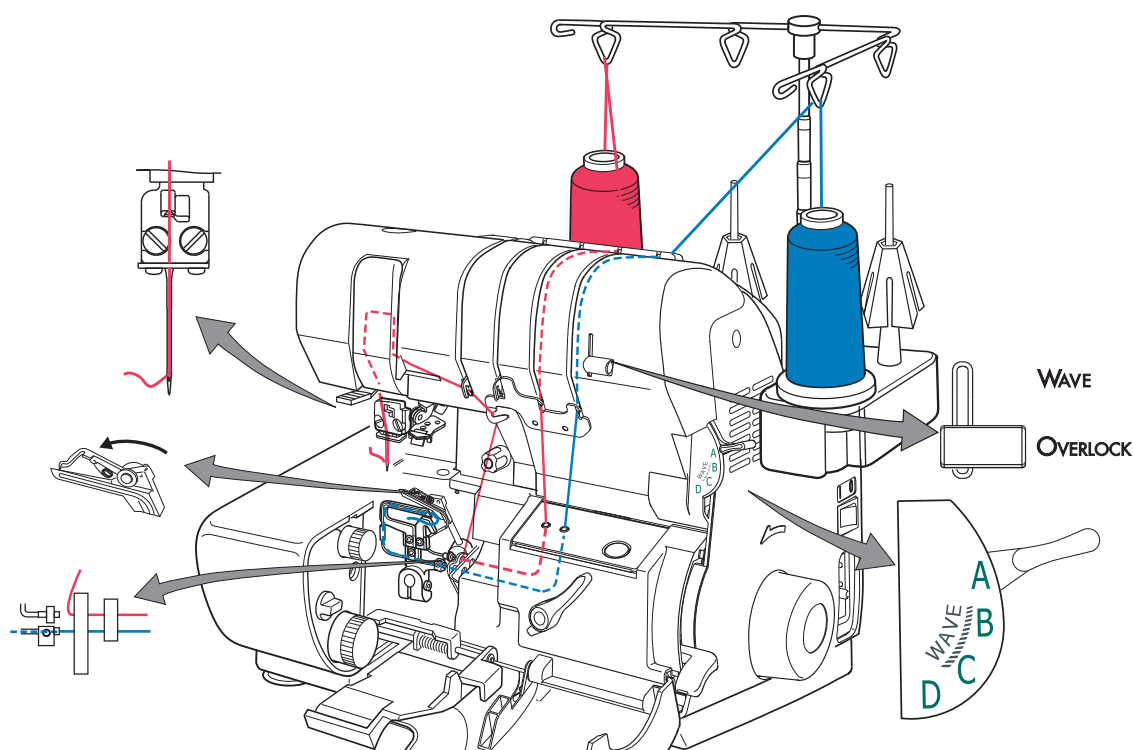

Returning to 3 or 4-Thread Overlock

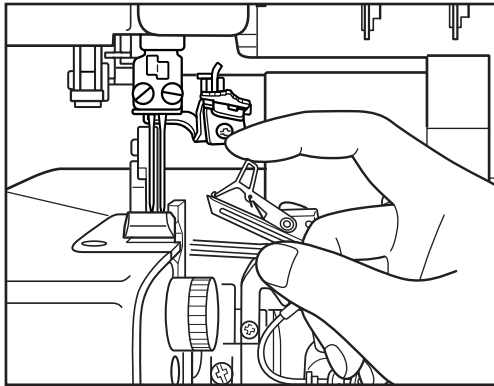

1. Open the front cover and rotate the handwheel forward to bring the upper looper to its highest position.
2. With your index finger or tweezers, move the subsidiary looper slightly to the back to release from the eye of the upper looper. Rotate it to the right until it snaps back into place and out of the way.
3. Engage the threading lever to the threading position. Rethread the upper looper (page 11). For 4-thread serging, replace the second needle (page 48). Rethread the needle (page 13). Engage the threading lever to the serging position.
4. Close the front cover.
5. Lower the foot and sew a test stitch.

Wave Stitch

The Wave Stitch provides a decorative "wavy" edging on fabric. (This is not to be confused with "Lettuce Edge" on page 36). The upper looper thread and the lower looper thread gradually appear every 25 stitches to create a stitch that looks like a "Wave". When using different color specialty threads (pages 46/47) for the upper or lower loopers, the Wave stitch creates an attractive stitch for edging.

When combining decorative threads for the Wave stitch, please sew test on a sample of the fabric you will be sewing on before applying the Wave stitch to your garment.

For best results, heavier decorative threads should be limited to the upper or lower looper at one time. Not both upper looper and lower looper at the same time. Wooly nylon in the corresponding looper and max-lock thread in the right needle will make a striking combination with the heavy decorative thread.

Converting from Normal Serging to Wave

1. Turn the Wave Selector lever from "OVERLOCK" to "WAVE".
2. Cut the threads from the thread cones and remove from the thread paths.
3. Engage the threading lever to the threading position (page 10).
4. Place the right needle thread cone on the far left spool pin.
5. Slip the right needle thread into the telescopic thread guide directly above the thread. Follow the left needle threading path down to the right needle.
6. Thread the right needle using the needle threader set on "R" (page 12).
7. Place the upper looper thread cone on the 2nd from left spool pin.
8. Slip the upper looper thread into the telescopic thread guide directly above the thread. Follow the top threading path for the right needle thread, down the front threading path, to the left of the chrome thread guide, and directly to the "U" threading port for the upper looper (page 11).
9. Place the right needle thread and upper looper thread under the presser foot and to the back.
10. Place the lower looper thread cone on the 3rd from left spool pin.
11. Slip the lower looper thread into the telescopic thread guide directly above the thread, then slip the thread into the lower looper telescopic thread guide to avoid the thread getting tangled while sewing. Take the thread through the standard lower looper threading path to the "L" threading port for the lower looper. Thread the lower looper (page 10).
12. Engage the threading lever to serging position.
13. Set Stitch Selector on "B" for Wave Stitch or "C" for Rolled Wave Stitch (page 34/35 for correct setting).
14. Set Stitch Length and Stitch Width following the illustration on page 34/35).

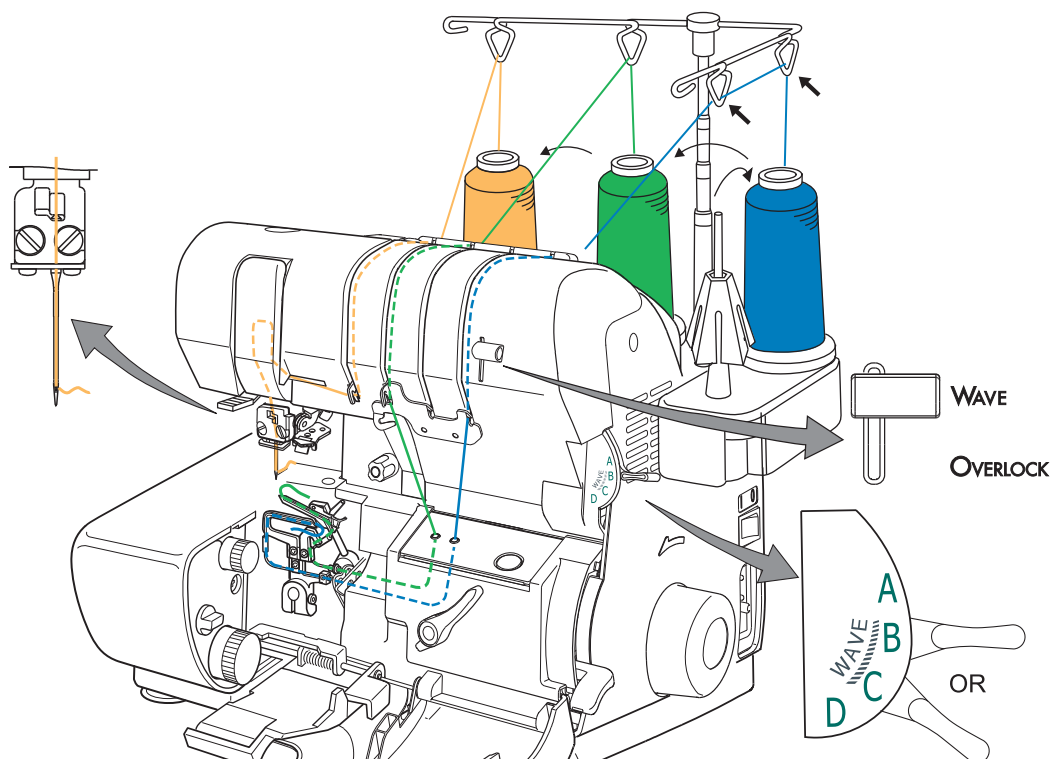

3-thread Wave Stitch

1. Turn the Wave Selector lever from "OVERLOCK" to "WAVE".
2. Cut the threads from the thread cones and remove from the thread paths.
3. Engage the threading lever to threading position (page 10).
4. Place the right needle thread cone on the far left spool pin.
5. Slip the right needle thread into the telescopic thread guide directly above the thread. Follow the left needle threading path down to the right needle.
6. Thread the right needle using the needle threader set on "R" (page 13).
7. Place the upper looper thread cone on the 2nd from left spool pin.
8. Slip the upper looper thread into the telescopic thread guide directly above the thread. Follow the top threading path for the right needle thread, down the front threading path, to the left of the chrome thread guide, and directly to the "U" threading port for the upper looper. Thread the upper looper (page 11).
9. Place the right needle thread and upper looper thread under the presser foot and to the back.
10. Place the lower looper thread cone on the 3rd from left spool pin.
11. Slip the lower looper thread into the telescopic thread guide directly above the thread, then slip the thread into the lower looper telescopic thread guide to avoid the thread getting tangled while sewing. Take the thread through the standard lower looper threading path to the "L" threading port for the lower looper. Thread the lower looper (page 10).
12. Engage the threading lever to serging position.
13. Set Stitch Selector on "B" for Wave Stitch.
14. Set Stitch Length and Stitch Width following the illustration below.

NEEDLES right	LENGTH 0.75-2.5	WIDTH 5.0	STITCH SELECTOR B	WAVE SELECTOR WAVE
------------------	--------------------	--------------	-------------------------	--------------------------

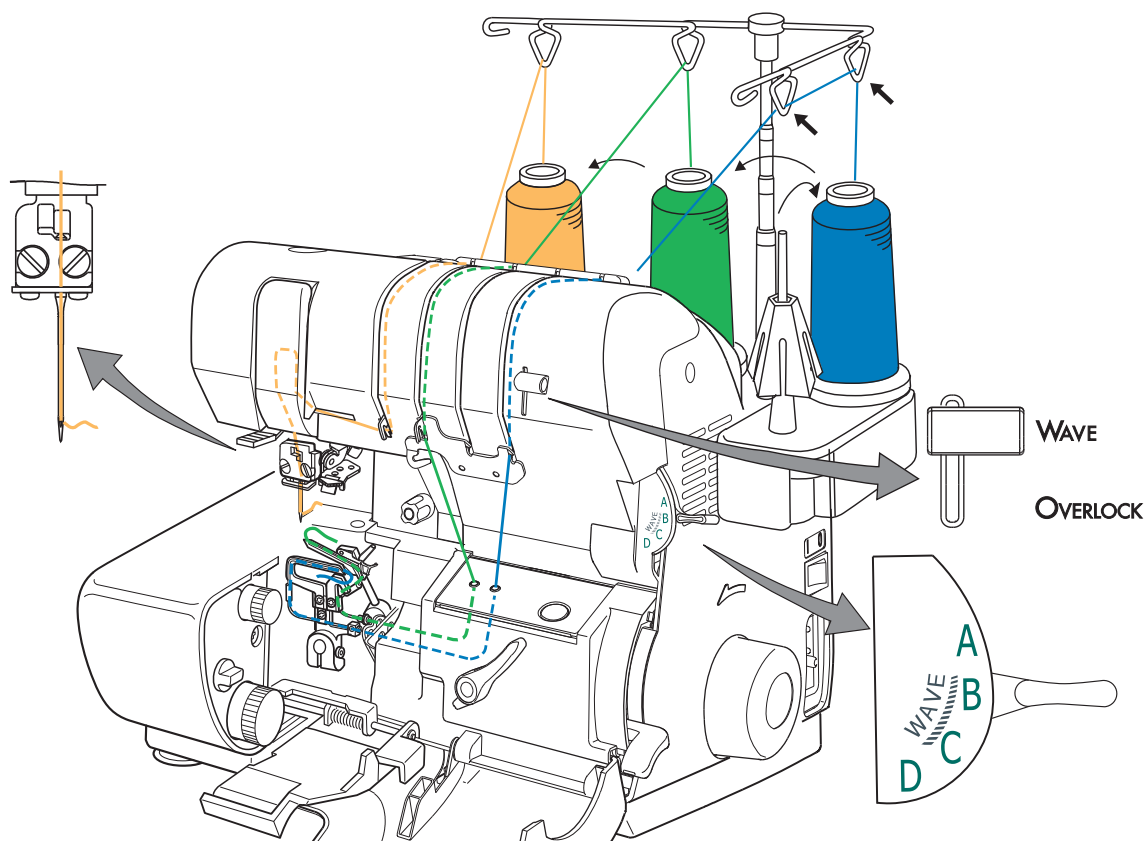

3-Thread Rolled Wave Stitch

1. Turn the Wave Selector lever from "OVERLOCK" to "WAVE".
2. Cut the threads from the thread cones and remove from the thread paths.
3. Engage the threading lever to threading position (page 10).
4. Place the right needle thread cone on the far left spool pin.
5. Slip the right needle thread into the telescopic thread guide directly above the thread. Follow the left needle threading path down to the right needle.
6. Thread the right needle using the needle threader set on "R" (page 13).
7. Place the upper looper thread cone on the 2nd from left spool pin.
8. Slip the upper looper thread into the telescopic thread guide directly above the thread. Follow the top threading path for the right needle thread, down the front threading path, to the left of the chrome thread guide, and directly to the "U" threading port for the upper looper. Thread the upper looper (page 11).
9. Place the right needle thread and upper looper thread under the presser foot and to the back.
10. Place the lower looper thread cone on the 3rd from left spool pin.
11. Slip the lower looper thread into the telescopic thread guide directly above the thread, then slip the thread into the lower looper telescopic thread guide to avoid the thread getting tangled while sewing. Take the thread through the standard lower looper threading path to the "L" threading port for the lower looper. Thread the lower looper (page 10).
12. Engage the threading lever in the serging position.
13. Set Stitch Selector on "C" for Rolled Wave Stitch.
14. Set Stitch Length and Stitch Width following the illustration below.

NEEDLES right	LENGTH 0.75-1.5R	WIDTH 3.0-5.5	STITCH SELECTOR C	WAVE SELECTOR WAVE
------------------	---------------------	------------------	-------------------------	--------------------------

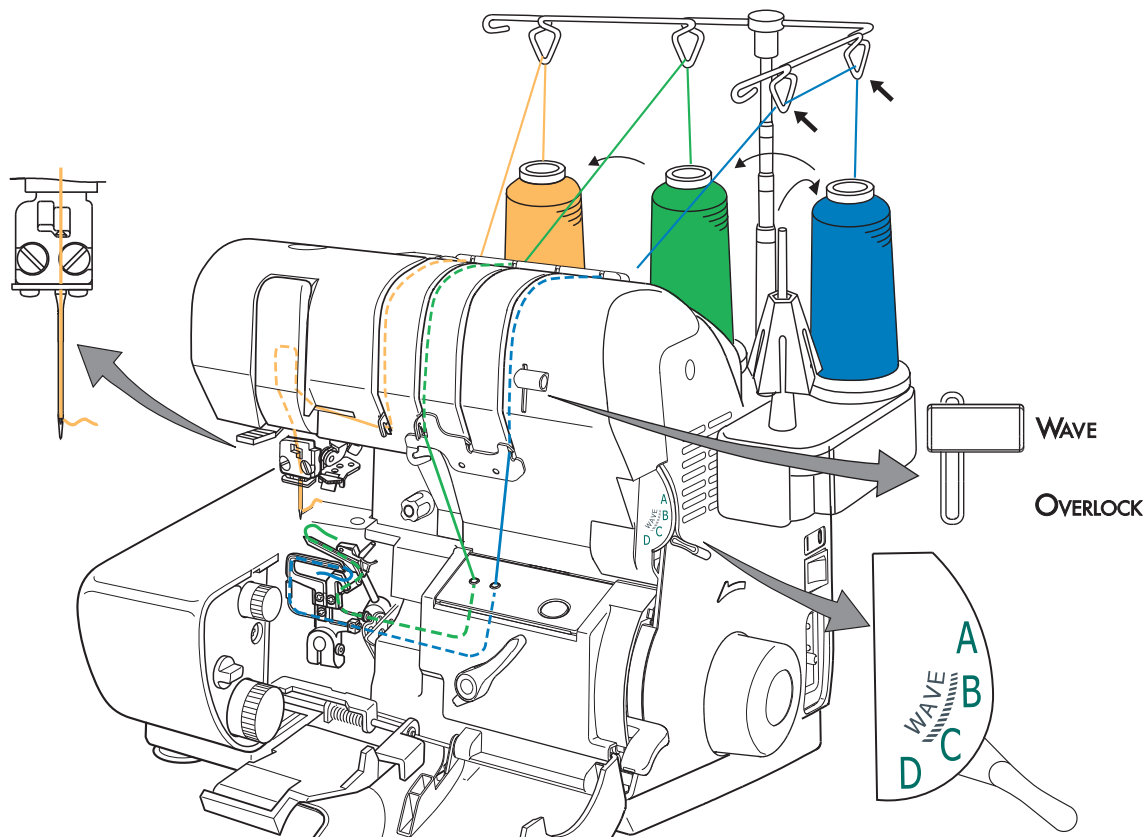

Rolled Edging

To convert "ROLLED EDGE", please refer to page 23 to change the settings and threading.

Seaming Sheers

Use the 3-thread rolled hem setting when sewing sheer fabrics that otherwise would require French seams. Set the stitch length at 2.5. Then simply sew the seams, aligning the fabric edges with the serger seam guide, trimming away the excess seam allowance.

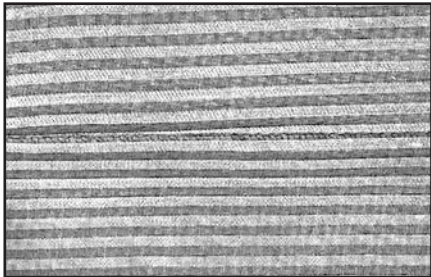
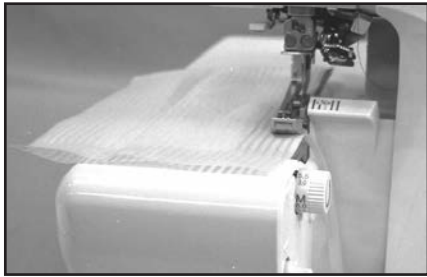

Lettuce Edge

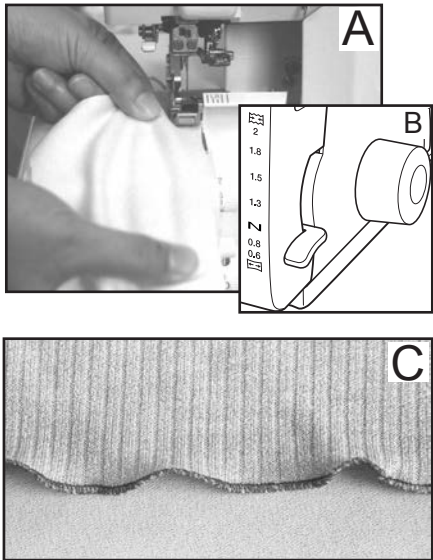

A frilly or "lettuce" edge can be created on most light and medium weight stretch fabrics and on bias edges of soft, woven fabrics. It makes a pretty decorative edging for activewear, lingerie, accessories and children's wear.

Set the machine for the 3-thread rolled edge (page 23).

Set differential feed at 0.6 (fig.B). Serge the fabric in the direction of greatest stretch - the crossgrain on knits, bias grain on wovens. For a "leafier" effect, try using a shorter stitch length and gently stretch the fabric (fig.A) as it is being sewn. Sew a test sample (fig.C).

Belt Loops and Button Loops

Use the rolled edge thread chain, stitched without fabric, to make professional belt loops and button loops. Using a heavy decorative thread in the upper looper forms a stronger loop.

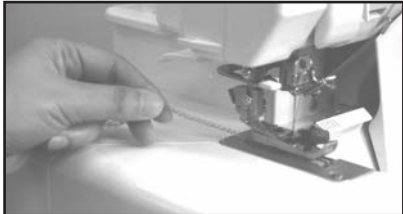

Returning to Standard Serging

Clear the stitch fingers and return the stitch length dial to the standard range. Set stitch width and length at the desired settings. Replace the left needle and its corresponding thread, if desired.

Overedging

Overedging to finish facings, hems and seams before construction, is one of the most basic uses of a serger, such as making a garment or project with 5/8 inch (16mm) pressed open seams (fig. A).

To overedge, place the single layer of fabric in front of the presser foot, aligning the cut edge with upper cutting blade. Begin serging, continuing to guide the fabric along the blade. The edge of the fabric should be trimmed, but not cut away. Then sew the seams on your conventional sewing machine and press them open as usual (fig. B).

Because notches would be cut away in this process, mark them before serging with "V" snips just inside the seam allowance or with a water-soluble fabric marker (fig. C).

Note: A 2-thread overlock or 3-thread overlock can also be used with this technique.

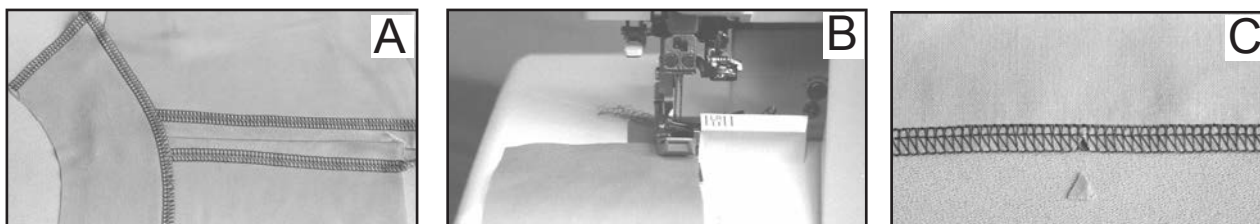

Seaming

For garments or projects that do not require conventional pressed-open seams, you can stitch and finish the seam in one operation and then press the seams to one side (fig. A). A 4 or 3-thread seam is strong, yet it provides "give" or flexibility according to the needs of the fabric.

Place two layers of fabric right sides together. Use the marks on your serger's front cover to align the fabric for the desired seam width. Keep your eye on the fabric edge to guide it to the appropriate mark (fig. B).

Do not watch the needle. If you guide the fabric accurately, the needle will seam in the correct place automatically.

Note: For most seaming, pins are unnecessary because the serger feeds the fabric evenly. If you need pins, place the pins parallel to the seam line outside the seam allowance to avoid damaging the blades.

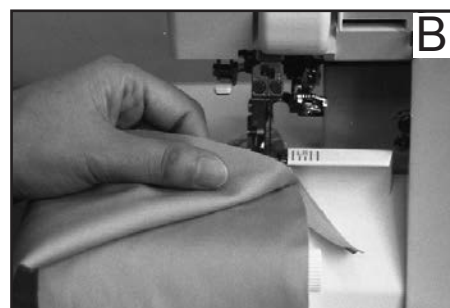
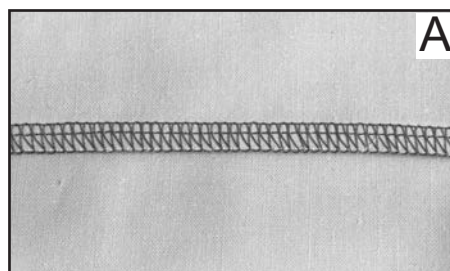

Front Cover Seam Guide

Use the marks on your serger's front cover and set the width dial at "M" to align the fabric for accurate seam allowances.

When using the left needle, the second mark "L" from the needle indicate 5/8 inch (16mm) from the cutting edge to the needle.

Use the right needle and the third mark "R" from the needle to indicate 5/8 inch (16mm) from the cutting edge to the needle.

Note: Be sure to set the width dial at the "M" setting for accurate seam allowances.

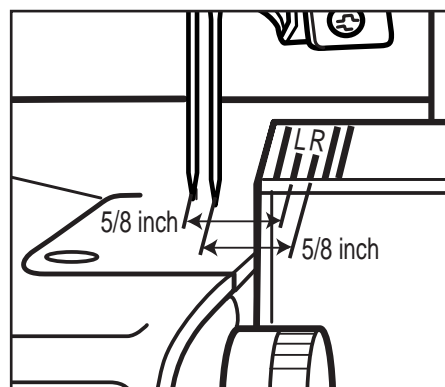

Securing Ends

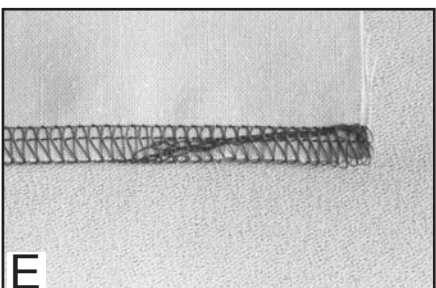
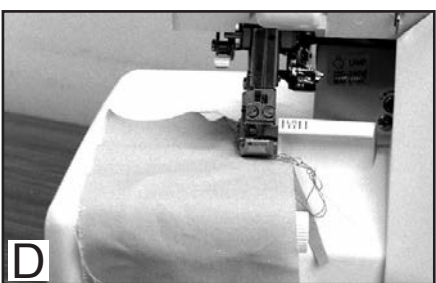
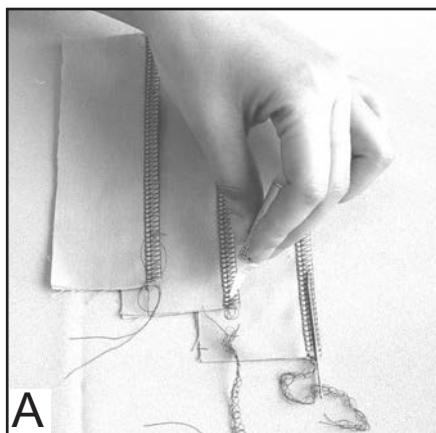

The serger stitch will not unravel readily, and in most cases serged seams are secured by an intersecting seam. If that's not the case, there are several options for securing a seam (fig. A).

1. Leave a 3 inch (7.5cm) chain, separate the threads and tie a knot.
2. Apply a dot of seam sealant on the thread chain at the fabric edge. Allow to dry and cut off the excess thread chain.
3. Leave a 3-4 inch (7.5-10cm) thread chain and use a large-eye tapestry needle or double-eye needle to weave the chain back into the stitching.
4. Lock the beginning or end of a seam by serging over the previous stitches.

To lock the beginning of the seam:

1. Manually turn the handwheel toward you taking 2-3 stitches into the fabric. Leave the needle(s) in the lowest position to anchor the fabric.
2. Raise the presser foot.
3. Smooth out the thread chain with your fingers (fig. B). Then bring the chain around and under the foot, so that it aligns with the edge of the fabric (fig. C).
4. Lower the foot and continue sewing, catching the thread chain in the stitches for about 1inch (2.5cm). Let the blades cut off any remaining thread chain (fig. D-E).

Securing Ends (Cont.)

To lock the end of the seam:

1. Take one stitch off the end of the seam (fig. A).
2. Raise the presser foot and bring the needle(s) to the highest position. Pull back gently on the fabric to clear the stitch fingers.
3. Turn the fabric over with the wrong side of the stitch facing up (fig. B), and reposition it under the presser foot with the needle at the seam edge, aligned with the previous needle line (fig. C).
4. Lower presser foot and sew 5-6 stitches over the previous stitches, being careful not to cut them. You may want to flip the cutting blade lock switch clockwise to the lock position. Pivot the fabric and chain off, (fig. D-E).

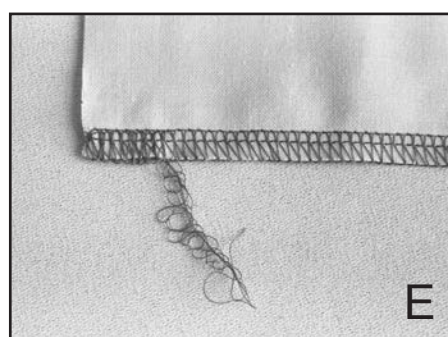
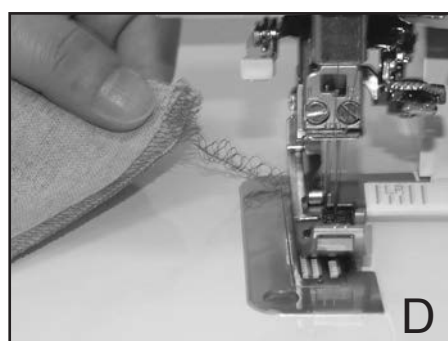
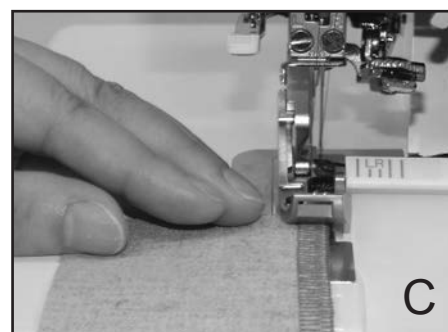
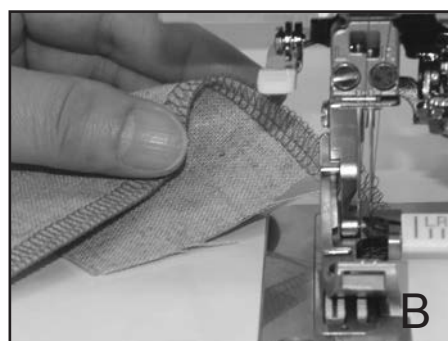
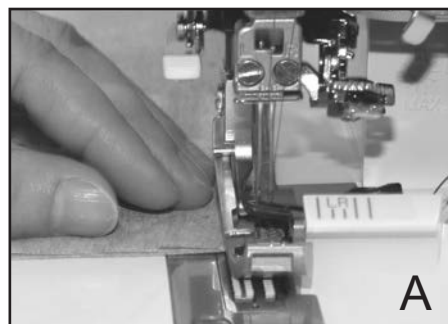

Turning Outside Corners

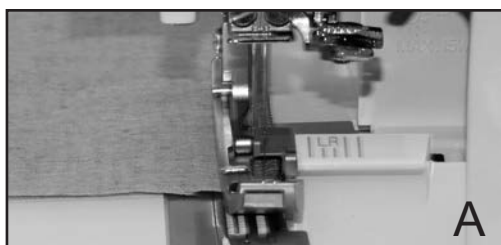

A



B

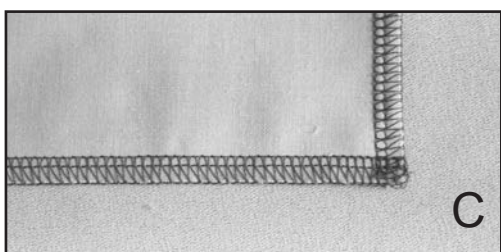

C

1. Stitch along one edge until you reach the corner. Take one stitch off the edge of the fabric (fig. A). (As you approach the edge, you may want to stop and manually turn the handwheel towards you.)
2. Raise the needle(s) to the highest position.
3. Clear the stitch fingers, and rotate the fabric to reposition the needle at the previous row of stitching (fig. B). Gently pull up on all threads to remove slack and resume stitching (fig. C).

Note: A loose thread loop at the corner is caused by too much slack in the needle thread when clearing the stitch fingers. Try again, turning corners takes a little practice!

Turning Inside Corners

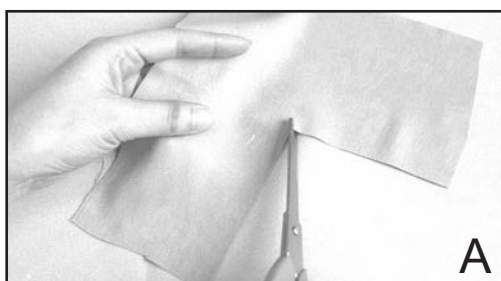

A



B

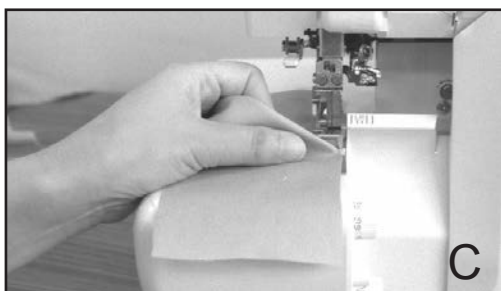

C

1. Reinforce loosely woven fabrics at the corner with staystitching on the conventional sewing machine. Clip to the corner (fig. A).
2. Align the fabric edge with the blade, and stitch until the blade reaches the corner, not the needles. Don't cut into the corner (fig. B).
3. Lower the needle(s) to anchor the fabric.
4. Raise the presser foot and straighten out the fabric edge, forming a fabric pleat at the corner (fig. C).
5. Be sure the marked stitching line is straight, then continue serging the remaining edge. When done correctly, the pleat will disappear after stitching (fig. D).

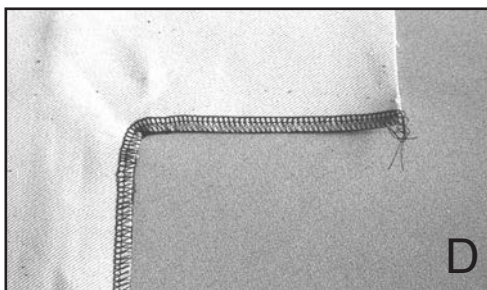

D

Serging Curves

To serge around inside or outside curves, guide the fabric into the cutting blade, not the needle(s). Remember, cutting takes place before the fabric reaches the needle. Because the long serger presser foot holds the fabric more securely, you may need to raise and lower the presser foot several times to maneuver around very tight curves.

Inserting Tapes

The slot in the standard presser foot is designed to guide stabilizing tape, narrow elastic or decorative ribbon into the stitching. Insert tape or elastic into the slot and under the back of the foot (fig. A). Adjust the stitch width to match the tape width. Place the fabric under the foot and stitch (fig. B).

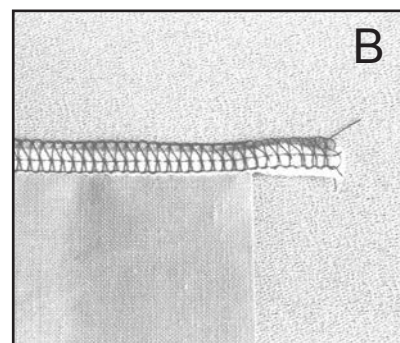
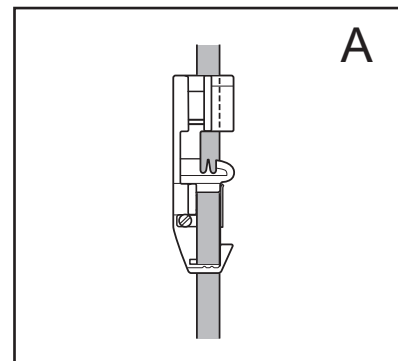

Using Specialty Threads

Beautiful stitches can be formed by serging with specialty threads, cords and ribbons. These heavier or shinier threads can be used to enhance appearance, add strength or elasticity, or create special effects, depending on the thread you choose.

Some specialty threads work well through the needle and loopers. There are some that are too heavy for the needle and should only be used in the loopers.

Use the Specialty Thread chart on pages 46/47 as a guide keeping in mind that the threads can vary from one manufacturer to another. It is best to sew test for best results.

Note: Thicker threads require longer stitch length.

Threading Lightweight Thread

Specialty thread used in the needle can be threaded in the usual way. The ease with which they can be threaded in the loopers, however, depends on thread thickness.

Changing Threads



1. Clip the existing thread at the cone and remove the cone from the spindle (fig.A).
2. Place the new cone on the spindle. With the two threads together, tie an overhand knot or square knot (fig.B).
3. Raise the presser foot, and pull the old thread from under the foot until the new thread comes through the machine.

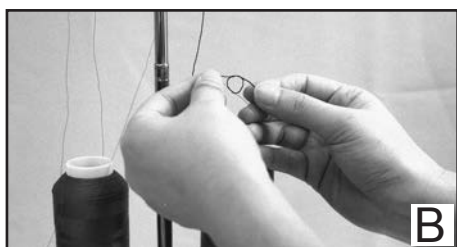

Note: When changing a needle thread, pull the thread through until it reaches the needle eye. Then clip off the knot (fig.C) and rethread the needle eye manually or with the needle threader.

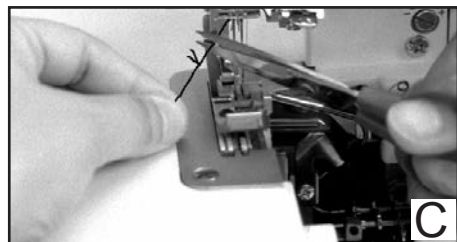

Threading Medium Weight Thread

Medium weight threads, including topstitching thread, Decor rayon and stretch nylon thread, are too bulky to form a knot that would fit through the threading port, but they can slip through the hole with the aid of a thread "cradle" made from regular serger thread (page 43).

Thread Cradle for Loopers

1. Open the front cover and raise the presser foot.
2. At the threading port, clip the looper thread that is to be replaced. (fig.A) Remove thread from under the foot and the upper thread guides. Replace cone of thread with specialty thread.
3. With the threading lever engaged in the threading position (fig. B) turn handwheel towards you to close looper tubes (fig. C).
4. Thread specialty thread into the upper thread guides, leaving an 18 inch (40cm) tail above the threading port (fig.D).
5. Cut a 24 inch (55cm) strand of serger thread and fold in half to form a thread cradle. Insert the loose ends of the thread cradle into the port about 1 inch (2.5cm).
6. Holding the cradle loop with your left hand, depress the "Push to Thread" Button with your right hand (fig.E) until the thread ends come out the looper eye. For chain looper, open side door of machine to make sure thread is in eye of chain looper.
7. Insert the specialty thread tail into the cradle loop (fig.F), pull the serger thread ends until the specialty thread comes through the looper eye (fig.G). Discard or set aside the thread cradle.
8. Run upper looper thread under the foot and to the left, cut lower looper thread to 4 inches (10cm) and leave it hanging loose.

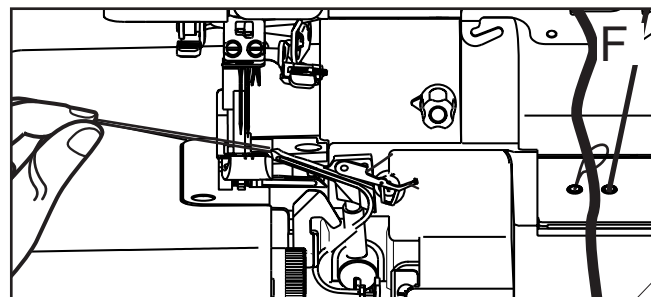
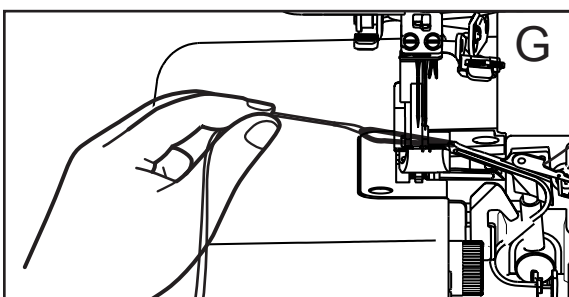
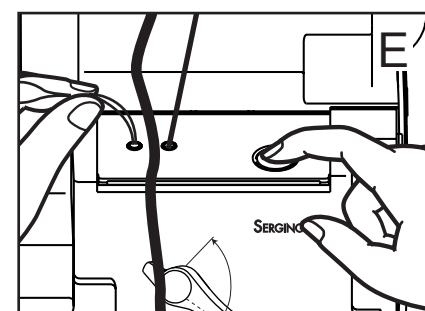
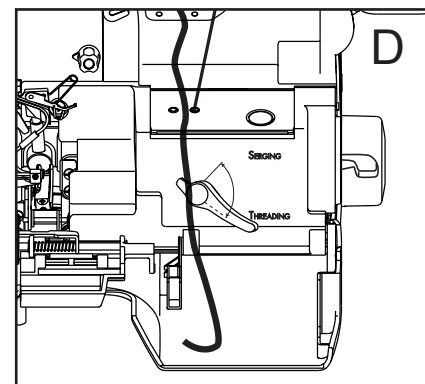
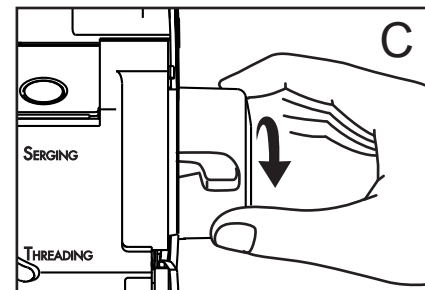
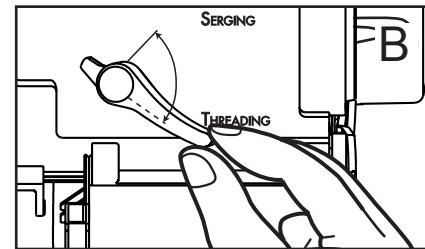
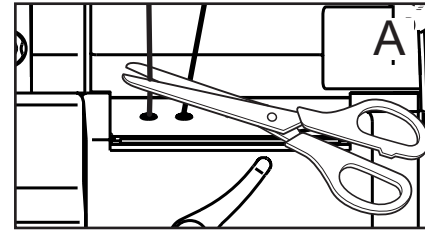

Looper Threading Tool

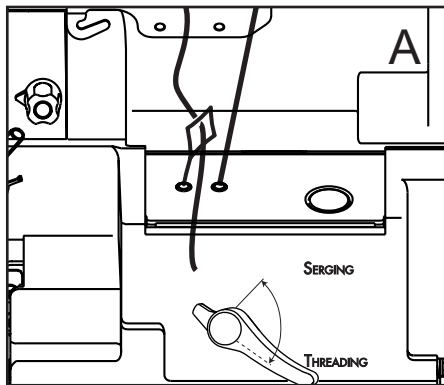

1. Open the front cover and raise the presser foot.
2. At the threading port, cut the looper thread that is to be replaced. Remove thread from under the foot and the upper thread guides. Replace cone of thread with specialty thread.
3. With machine engaged in threading position.
4. Thread specialty thread into the upper thread guides, leaving an 18 inch (45cm) tail above the threading port.
5. Place the straight end of the looper threading tool into the threading port. Push the looper threading tool until the end comes out of the looper eye.
6. Insert the specialty thread tail into the looper threading tool eye (fig.A). Pull the straight end of the looper threading tool through the looper eye bringing the specialty thread with it. (fig.B)

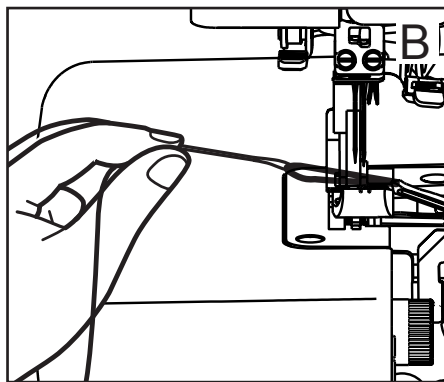

Bypassing the Threading Port

Heavy weight threads can be used through your regular looper thread paths. Specific techniques may require that the thread bypass the thread port for the thread pull to be loosened. Start with the machine threaded with regular serger thread.

1. Open front cover and raise the presser foot.
2. Just above the threading port, clip the looper thread to be replaced. Pull the thread out of the upper guides and remove the cone.
3. Place the specialty thread on the spool pin. Thread it into the upper guides and clip it a couple of inches beyond the base plate (fig. A).
4. With machine engaged in the serging position, hold the thread end at the looper eye and use the tweezers to pull the existing looper thread out of tube extending from the threading mechanism (fig. B). Leave the thread in the tubular looper.
5. Tie the specialty thread onto the regular thread with an overhand knot (fig. C). Pull on the regular thread from the looper eye until the specialty thread comes through the looper eye.
6. Place upper looper thread under the foot and to the left: clip lower looper thread at the base plate.

If the thread is heavy and the overhand knot (step #5) is too large for the looper tube, (follow directions #1 thru #6 on page 43) to make a thread cradle. Then:

1. Engage in the serging position.
2. While holding the loose ends of the thread cradle with one hand, use the tweezers to pull the cradle loop out of the tube extending from the threading mechanism with the other hand.
3. Insert 2 inch(5cm) of your decorative thread into the cradle loop. Pull on the loose ends of the thread cradle from the looper eye until the specialty thread comes through the looper eye.

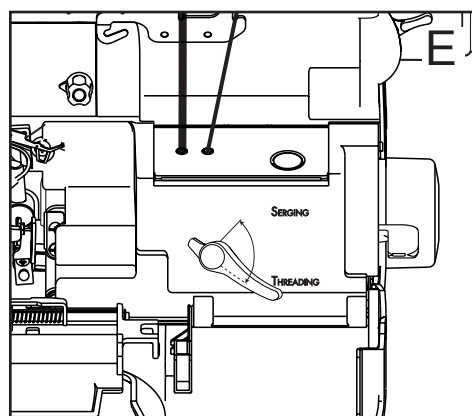
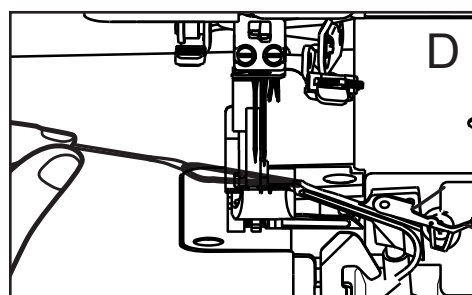
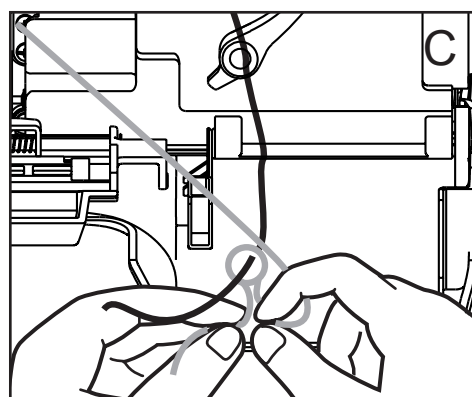
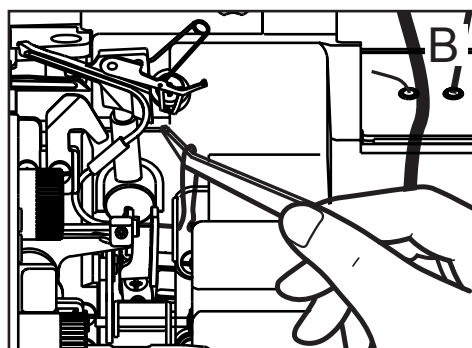
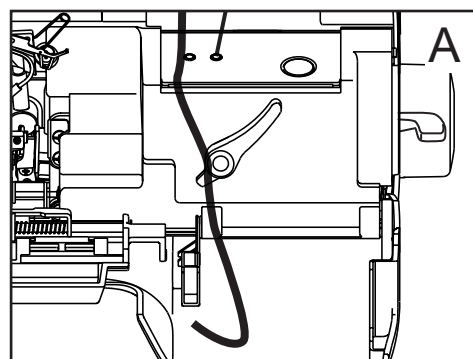

Specialty Thread Guide Chart

	Topstitching Buttonhole Twist	Woolly Nylon Thread	Machine Embroidery Metallic Threads
APPLICATION	Edging or flatlock seaming for sportswear and home décor items.	Soft stretchy seams on lingerie, swimwear, active wear, and for rolled edge stitch.	Decorative edges for clothing, gift items, home décor, etc.
4-Thread Seaming	Yes	Yes	Yes For exposed edges only
3-Thread Seaming	Yes	Yes	Yes For exposed edges only
2-Thread Flatlock	Yes	Yes	Yes In lower looper
4-Thread Edging	Yes	Yes	Yes
3-Thread Edging	Yes	Yes	Yes
3-Thread Rolled Edge	Use in upper looper only	Yes	Use in upper looper only
3-Thread Wave	In upper or lower looper. Not in both loopers at once	In upper or lower looper. Not in both loopers at once	In upper or lower looper. Not in both loopers at once
3-Thread Rolled Wave	Use in upper looper only	In upper or lower looper. Or both loopers	In upper or lower looper. Or both loopers
Blanket Stitch	In needle only	In lower looper	Not recommended
Ladder Stitch	In needle only	In lower looper	In needle only
COMMENTS	When using decorative thread in the needle use a size 90 Top Stitch needle for best results.	Can be used in the needle	Varies greatly with manufacturer. Avoid thread with coarse metal fibers. Sew test before sewing on project.

Specialty Thread Guide Chart (Cont.)

	Clear Nylon Monofilament	Machine Embroidery Threads: Rayon and Polyester, 30, 40, 50 weight. Lingerie Thread	Designer 6 Pearl Crown Rayon Candlelight Jeans Stitch Ribbon Thread
APPLICATION	Techniques requiring the thread to be invisible such as blind hemming	Lingerie and lightweight fabrics, edging of fine fabrics, delicate rolled hems.	Decorative edging, flatlocking, rolled hem, wave stitch, rolled wave stitch, etc.
4-Thread Seaming	Not recommended	Lingerie thread for seams.	Not recommended for seaming
3-Thread Seaming	Blind hemming	Lingerie thread for seams.	Not recommended for seaming
2-Thread Flatlock	Blind hemming	Lingerie thread for seams.	Use in the lower looper
4-Thread Edging	Not recommended	Machine embroidery thread only.	Use in the upper and lower loopers.
3-Thread Edging	Not recommended	Machine embroidery thread only.	Use in the upper and lower loopers.
3-Thread Rolled Edge	Lengthen stitch slightly	Machine embroidery thread in upper looper	Use in the upper looper only (Excluding Ribbon Thread)
3-Thread Wave	Not recommended	Machine embroidery thread in the upper and lower loopers.	Use in the upper looper or lower looper. Not both loopers at once.
3-Thread Rolled Wave	Not recommended	Machine embroidery thread in the upper looper.	Use in the upper looper only
Blanket Stitch	Not recommended	Not recommended	Use in the needle only with a size 90 Top Stitch needle (Excluding Ribbon Thread)
Ladder Stitch	Not recommended	Not recommended	Use in the needle only with a size 90 Top Stitch needle (Excluding Ribbon Thread)
COMMENTS	Make sure to use a soft pliable monofilament thread Sew at a slower speed.	Use thread nets to prevent the thread from falling off the spool and getting tangled.	Be sure to check the recommendations above for best results. Sew test before applying to the project.

Replacing Needles

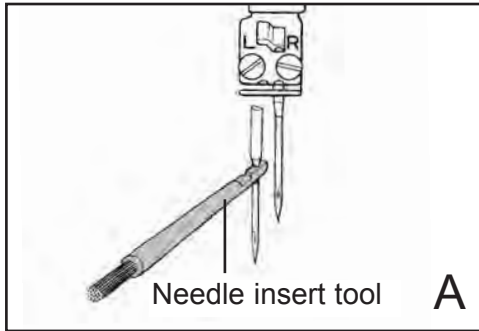

1. Raise the needle to the highest position by turning the handwheel toward you.
2. Using the screwdriver from the accessory pouch, loosen the needle screw for the needle to be changed. "L" screw for the left needle and "R" screw for the right needle as shown in (fig. A).

Note: To prevent the needle from falling into the needle plate, hold it with the needle insert tool as you loosen the needle screw. (fig. A)

3. Use the needle insert tool or tweezers to insert the new needle with the flat side to the back. Insert the needle as far as it will go. Check the needle viewing window. (fig. A)
4. Tighten the needle screw.

Note: If you do drop a needle down into the machine just pull out the needle-drop drawer at the bottom of the serger. The needle will be on the drawer. (fig. B)

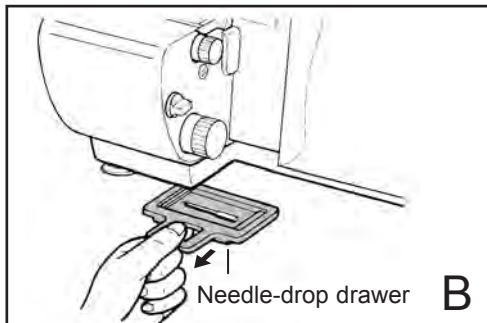

Replacing Cutting Blades

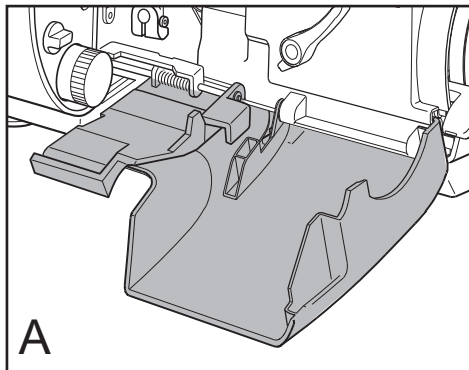

The lower fixed blade is made of a special long lasting steel and does not require frequent replacement. If necessary, contact your nearest Baby Lock retailer for replacement of this blade.

The upper moving blade is made of a softer steel material and will require replacement. A spare blade is provided with the machine for replacement if necessary. The spare blade is located in the thread spool stand accessory compartment.

If for some reason your machine does not cut or perform as it should, please take your machine to your nearest Baby Lock retailer. It is possible that the result of poor cutting may indicate other problems.

To replace the upper moving blade, follow below instructions.

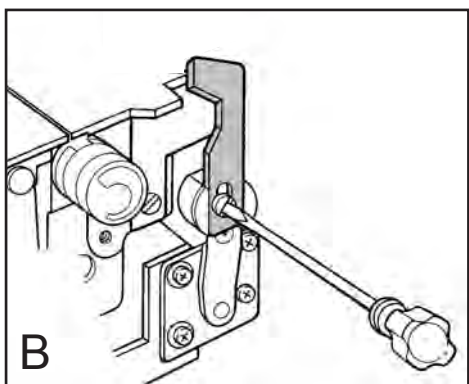

1. For safety reasons, unplug main power cord.
2. Open front cover and cutting blade cover (fig. A). Remove presser foot.
3. Turn handwheel so upper moving blade is in its highest position.
4. Remove screw and upper blade. (fig.B)
5. Insert new blade into blade slot.
6. Insert screw and hold moving blade in its highest position while tightening the screw.

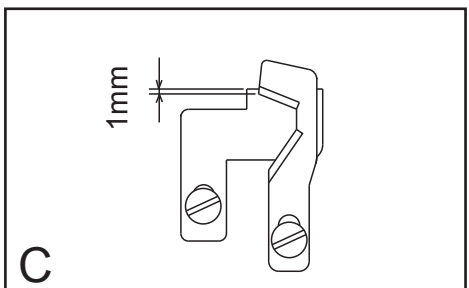

7. To finalize position of upper blade, turn handwheel so that the moving blade is in it's lowest position. Loosen the screw so that the moving blade can be lowered to 1mm overlap of the top of the fixed blade (fig. C). Tighten the screw.
8. Close cutting blade cover and front cover. Replace the presser foot
9. Rotate the handwheel one turn to ensure smooth operation of the machine.

Cleaning

Your Baby Lock will operate at best performance if it is kept clean at all times. The serger's cutting action creates much more lint than you will find on conventional sewing machine.

Your serger's major moving parts are well protected and do not need to be oiled. However, we recommend that you use the cleaning brush often during garment construction in order to keep lint off the blades, the needle bar, the feed dog mechanism and loopers. If machine needs to be oiled, check with your nearest Baby Lock retailer for use of high grade recommended sewing machine oil.

TO REMOVE NEEDLE PLATE PROCEED AS FOLLOW:

1. For safety reasons, unplug main power cord.
2. Raise and remove presser foot.
3. Select stitch length dial to rolled hem setting.
4. Remove needles from needle clamp.
5. Turn your handwheel until the upper looper is in the far right position.
6. To remove the needle plate, remove front screw with screwdriver and back screw with allen wrench (fig. A).
7. With your right hand, first raise the needle plate in front of the blade. Pull slightly to the right, then remove to the left.
8. Replace in reverse procedure.
9. Finally, position the needle plate so that the needles lower in the center of each hole on the needle plate (fig.B). Then tighten both screws.

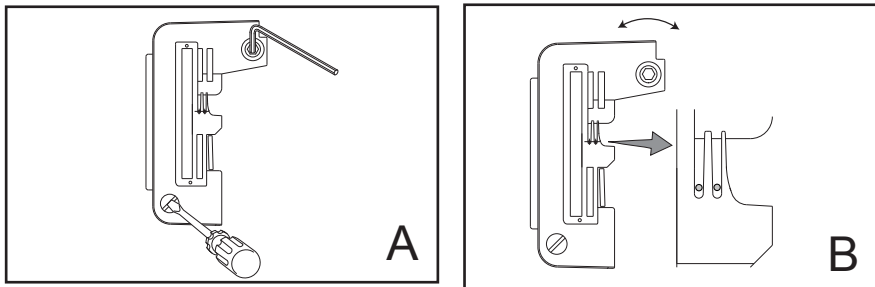

Replacing LED Lighting

Your Baby Lock Enlighten is equipped with long-life LED lighting system, which is not necessary to change bulbs.

In case of replacing LED unit, please contact your authorized Baby Lock dealer.

Troubleshooting

Before taking your machine in for service, check the following:

Machine fails to start:

1. Are electrical plugs properly connected?
2. Is the power switch on?
3. Check household circuit breaker or fuse.
4. Is the lock button release lever in the unlocked position?

Thread breaks:

1. Is the machine threaded correctly? Check each thread path carefully.
2. Is the needle inserted correctly?
3. Is the needle bent and worn?
4. Is the stitch selector on the proper setting?
5. Are you using good quality thread?
6. Is the thread feeding off the cone/spool freely?
7. Is the needle size correct for the type of fabric being used?
8. Are the needles being used the correct Organ or Schmetz HAx1SP/CR system?

Skipped Stitches:

1. Is the needle bent or worn?
2. Is the needle inserted correctly?
3. Is the serger threaded correctly?
4. Is the presser foot pressure right for the fabric?
5. Is the correct needle being used for the particular stitch?
6. Is the correct needle being used for the type of fabric being sewn?
7. Is the fabric being pulled from the rear of the machine while sewing?

Fabric will not feed in machine:

1. Is the machine engaged in the serging position?
2. Is the presser foot down?
3. Are the cutting blades sharp?
4. Are the cutting blades, presser foot, and feed dogs free of lint?
5. Are the cutting blades properly set and is the upper blade against the lower blade?
6. Is the presser foot pressure right for the fabric?
7. Is the stitch length set properly?
8. Is the needle plate secure on the machine?

Stitch is Unbalanced:

1. Is the serger threaded correctly?
2. Is the stitch selector on the proper setting?
3. Is the thread well seated in the thread slots?
4. Is the looper thread fine-tuning screw positioned correctly?

Note: If you change the position of the looper thread fine-tuning screw and stitch is unbalanced, return the screw to the standard position and recheck the stitch (page 13 for illustration).

Troubleshooting (Cont.)

Needle threading difficulties:

1. Is the needle threader selector at the appropriate setting? ("R" for right needle, "L" for left needle.)
2. Is the machine in the locked position?

Looper threading difficulties:

1. Is the machine engaged in the threading position?
2. Is the looper threader selector at the appropriate setting? (Left threading port for "U" upper looper, right threading port for "L" lower looper.)
3. Is the thread end in the proper threading port?
4. Is at least 1/2 inch (1.2cm) of the thread end in the threading port?
5. Is there at least 18 inches (45cm) of loose thread beyond the thread guide above the threading port?
6. Is there a kink or twist in the 18 inch (45cm) of thread to restrict the flow into the threading port?
7. Is the thread restricted from going through the loopers?

Poor Cutting:

1. Are the cutting blade(s) dull?
2. Have you sewn over a straight pin?
3. Is the cutting blade in the locked position?
4. Have the cutting blades been improperly replaced?
5. Is the fabric being pulled from the rear of the machine while sewing?

Wave Stitch is not forming correctly:

1. Is the machine threaded correctly? Check each thread path carefully.
2. Is the machine set for 3-Thread Wave sewing?
3. Is the Wave Selector set on "WAVE"?
4. For rolled wave edging, is the stitch length dial set for "ROLLED HEM" ?
5. Is the Stitch Selector set correctly? Set the Stitch Selector at "B" for 3-Thread Wave Stitch or "C" for 3-Thread Rolled Wave Stitch.

Dos and Don'ts

1. Always be aware of the needle's up-and-down movement, and do not turn your attention from the machine while it is running.
2. When changing the needle, the presser foot or any other parts, always disconnect the machine by turning the power switch to OFF.
3. Do not place anything on the foot control, or the machine will start inadvertently and the foot control or motor can burn out.
4. When using your serger for the first time, place a fabric scrap under the presser foot and run the machine without thread for a few minutes. Wipe away any oil that appears.
5. Do not pull fabric from the rear of the machine. Such action can damage the machine.
6. To prevent possible injury, always avoid body contact with any moving parts and the machine mechanism.
7. NEVER sew over pins.

Special Caution: Unplug the power cord from the electrical outlet when the machine is not in use.

Technical Data

Stitch Types:	<p>2 needles, 2 loopers: 4-Thread Overlock</p> <p>1 needle (left or right), 2 loopers 3-Thread Overlock (wide, narrow, and narrow hem) 3-Thread Flatlock (wide and narrow) right needle only 3-Thread Rolled Edge 3-Thread Wave 3-Thread Rolled Wave</p> <p>1 needle (left or right), 1 looper 2-Thread Flatlock (wide and narrow) 2-Thread Blanket Stitch 2-Thread Ladder Stitch</p>
Stitch Width:	<p>Stitch Width Standard 2/3/4 - thread with left needle: 5.0 - 7.5mm</p> <p>Standard 2/3/4 - thread with right needle 3-Thread Wave Stitch with right needle 3.0 - 5.5mm</p> <p>3-Thread Rolled Edge 1.5mm</p>
Stitch Length:	<p>Stitch Length:</p> <p>2/3/4 Thread Overlock Stitch: 0.75-4mm 3-Thread Rolled Edge: 0.75-4mm</p>
Differential Feed:	<p>Gathering effect: N-2 Stretching effect: N-0.6</p>
Presser Foot:	Snap-on serger feet
Handwheel:	Rotates forward
Needle System:	Organ or Schmetz HA x 1SP/CR
Sewing Speed:	Up to 1500 s.p.m
Machine Weight:	8.5KG/19lbs.
Light System:	3 LED Lights

Chart for Stitch Selection Settings

Stitch Type	Stitch Length	Stitch Width	Needle	Stitch Selector	Differential Feed	Wave Selector	Page
4-Thread Overlock	2.5-3.5	6.0-7.5	Left + Right	A	N	O	19
4-Thread Gathering	4	6.0-7.5	Left + Right	A	2.0	O	17
3-Thread Overlock Wide	2-3	7.5	Left	A	N	O	20
Narrow	3.0-3.5	3.0-3.5	Right	B	N	O	21
3-Thread Narrow Hem	0.75-4.0R	3.0	Right	C	N-0.6	O	22
3-Thread Rolled edge	0.75-4.0R	3.5	Right	D	N-0.6	O	23
3-Thread Flatlock	2-3	3.0-5.0	Right	D	N	O	24
2-Thread Flatlock Wide	2-2.5	7.5	Left	A	N	O	26
Narrow	3-3.5	3.5	Right	B	N	O	27
3-Thread Wave Stitch	0.75-2.5	5.0	Right	B	N	W	34
3-Thread Rolled Wave	0.75-1.5R	3.0-5.0	Right	C	N	W	35

This change indicates the suggested range of settings for each stitch category. Make adjustments to the stitch length and width settings according to fabric weight and thread type.