

# *Ovation*<sup>TM</sup>

## *Instruction and Reference Guide*

Model BLES8



**FOR THE LOVE OF SEWING**

To register your machine warranty and receive Baby Lock product updates and offers, go to [www.babylock.com/profile](http://www.babylock.com/profile). If you have questions with registration, visit your Authorized Baby Lock Retailer.

Baby Lock Consumer Helpline: 800-313-4110

[www.babylock.com](http://www.babylock.com)

# Welcome to the Baby Lock Ovation

Your Baby Lock Ovation provides chain stitching, cover stitching, and overlocking. The Baby Lock Ovation has an exclusive "Thread Delivery System" that eliminates confusing tension adjustments. The Ovation enables you to accomplish a perfect stitch with any type of thread on any type of fabric. You no longer need to guess at the correct tension adjustments.

The Ovation is equipped with an exclusive Push to Thread "Electronic Extraordin Air Threading System".

It is no longer necessary to select the threading position. All looper threads may be threaded at the same time or individually.

Your Baby Lock Ovation is a high-quality, dependable machine. It gives you the ability to seam, overcast and trim all in one operation. Fabrics and threads you previously avoided are now a joy to sew because the Baby Lock Ovation handles all varieties with equal ease. With the Baby Lock Ovation your creative options are endless and your time spent serging is more fulfilling and rewarding. With the "Extraordin Air Threading System", even threading the Ovation is a breeze.

With proper care and maintenance, your Baby Lock Ovation promises years of high-quality, dependable performance and sewing pleasure. Keep this instruction manual as a step-by-step guide to become familiar with your Baby Lock Ovation and expand your sewing horizons.

**For additional product information and updates, visit our website at [www. babylock. com](http://www.babylock.com).**

Happy Sewing!



# Table of Contents

|  |     |
|--|-----|
| <b>OVERVIEW</b> .....                                | 4   |
| How Your Machine Operates .....                      | 4   |
| Overview of the Ovation .....                        | 5   |
| Accessories .....                                    | 6   |
| Needles.....   | 7   |
| Thread .....   | 7   |
| Optional Accessories .....                           | 7   |
| Setting Up Your Ovation .....                        | 8/9 |
| Cutting Blade Locking Dial .....                     | 10  |
| Upper Looper Positioning Knob.....                   | 10  |
| Cutting Blade Cover and Sewing Table .....           | 10  |
| Thread Cutter.....                                   | 11  |
| Presser Foot Pressure Adjustment .....               | 11  |
| Snap-on Presser Foot.....                            | 11  |
| Stitch Length / Rolled Hem .....                     | 12  |
| Stitch Width.....                                    | 12  |
| Differential Feed .....                              | 13  |
| Overlock Thread Delivery System .....                | 14  |
| Stitch Selector Lever.....                           | 14  |
| Wave/Overlock Selector Lever .....                   | 14  |
| Side Cover .....                                     | 14  |
| Chain/Cover Stitch Tension Dials.....                | 15  |
| Chain/Cover Stitch Needle Tension Dial .....         | 15  |
| Chain/Cover Stitch Looper Tension Dial .....         | 15  |
| 2-Thread Subsidiary Looper .....                     | 16  |
| Upper and Lower Looper Thread Fine-Tuning Knob ..... | 16  |
| Sewing Speed Controller .....                        | 17  |
| Knee Lifter .....                                    | 17  |
| <b>THREADING</b> .....                               | 18  |
| Threading Preparation .....                          | 18  |
| Threading Your Ovation .....                         | 19  |
| Locked Position for Threading .....                  | 19  |
| Thread Stand and Thread Port Reference Chart.....    | 19  |
| Lower Looper.....                                    | 20  |
| Upper Looper.....                                    | 20  |
| Chain Looper .....                                   | 21  |
| Chain/Cover Needles.....                             | 22  |
| Left Chain/Cover Needle - C-1 .....                  | 22  |
| Center Chain/Cover Needle - C-2 .....                | 22  |
| Right Chain/Cover Needle - C-3.....                  | 22  |
| Overlock Needles .....                               | 23  |
| Left Overlock Needle - O-1 .....                     | 23  |
| Right Overlock Needle - O-2.....                     | 23  |
| How to Use the Needle Threader .....                 | 24  |
| Cutting Blade Cover Seam Guide .....                 | 24  |
| Start to Sew .....                                   | 25  |
| To Chain-Off of the Fabric.....                      | 25  |
| Clearing the Stitch Width Fingers .....              | 26  |
| Re-threading Loopers .....                           | 26  |
| <b>OVERLOCK STITCHES - Express Stitches</b> .....    | 27  |
| 4-Thread Overedging .....                            | 27  |
| Overlock Seam .....                                  | 27  |
| 4-Thread Overlock.....                               | 28  |
| 3-Thread Overlock - Wide.....                        | 29  |
| 3-Thread Overlock - Narrow .....                     | 30  |
| 3-Thread Overlock - Narrow Hem.....                  | 31  |
| Rolled Edging .....                                  | 32  |
| 3-Thread Rolled Edge .....                           | 32  |
| Seaming Sheers .....                                 | 33  |
| Lettuce Edge .....                                   | 33  |
| Belt Loops and Button Loops.....                     | 33  |
| Returning to Standard Serging .....                  | 33  |
| 3-Thread Flatlock - Narrow .....                     | 34  |
| 2-Thread Overlock.....                               | 35  |

# Table of Contents (Cont.)

- Converting from 3-Thread to 2-Thread Overlock..... 35
- 2-Thread Flatlock - Wide ..... 36
- 2-Thread Flatlock - Narrow ..... 37
- Blanket Stitch - Decorative Stitch ..... 38
- Ladder Stitch - Decorative Stitch ..... 39
- Wave Stitch ..... 40
- Converting from Normal Serging to Wave ..... 40
- 3-Thread Wave Stitch ..... 41
- 3-Thread Rolled Wave Stitch ..... 42
- 3-Thread Reversed Wave Stitch ..... 43
- CHAIN/COVER STITCH - Express Stitches**..... 44
- Chain Stitching ..... 44/45
- Chain Stitch - Tension Adjustment ..... 45
- Cover Stitch - Right Narrow - 3mm ..... 46/47
- Cover Stitch Tension Adjustment ..... 47
- Cover Stitch - Left Narrow - 3mm ..... 48/49
- Cover Stitch Tension Adjustment ..... 49
- Cover Stitch - Wide - 6mm ..... 50/51
- Cover Stitch Tension Adjustment ..... 51
- Triple Cover Stitch - 6mm ..... 52/53
- Triple Cover Stitch Tension Adjustment ..... 53
- COMBINATION STITCH - Expressive Stitches** ..... 54
- 4-Thread Safety Stitch ..... 54/55
- 5-Thread Safety Stitch ..... 56/57
- 7-Thread Wave Stitch ..... 58/59
- 7-Thread Reversed Wave Stitch ..... 60/61
- 8-Thread Stitch ..... 62/63
- Expressive Stitches: Chain/Cover Stitches Combined with Overlock Stitches ..... 64
- Expressive Combinations ..... 64/65
- TECHNIQUES** ..... 66
- Turning Corners - Chain Stitch ..... 66
- Turning Corners - Cover Stitch ..... 66
- Turning Outside Corners - Overlock ..... 67
- Turning Inside Corners - Overlock ..... 67
- Flat Hemming - Cover Stitch ..... 68
- Hemming in the Round - Cover Stitch ..... 68
- Blind Hemming - Overlock ..... 69
- Tapes Slots ..... 70
- Inserting Tapes - Overlock ..... 70
- Inserting Tapes - Cover Stitch ..... 70
- Flatlock "Decorative" - Overlock ..... 71
- Securing Ends - Overlock ..... 72/73
- Securing Chain and Cover Stitching ..... 74
- Notes ..... 75
- SPECIALTY THREADS** ..... 76
- Using Specialty Threads ..... 76
- Lightweight Threads ..... 76
- Medium weight Threads ..... 76
- Heavy weight Threads ..... 76
- Bypassing the Threading Port ..... 77
- Looper Threading Tool ..... 78
- Thread Cradle for Loopers ..... 79
- Specialty Thread Guide Chart ..... 80/81
- MAINTENANCE** ..... 82
- Troubleshooting ..... 82/83
- Replacing Needles ..... 84
- Replacing Cutting Blades ..... 85
- Replacing LED Lighting ..... 85
- Cleaning ..... 86
- TECHNICAL DATA** ..... 87
- Technical data ..... 87
- STITCH SELECTION CHART** ..... 88
- Chart for Stitch Selection Setting for Chain/Cover and Combination Stitches .. 88/89

## How Your Machine Operates

Sometimes called an overlock machine or overlocker, the serger is different from any conventional sewing machine you have used. Awareness of its simple operation will enable you to become more proficient in its use. Please read all instructions before using your new machine.

A serger is kind of a knitting process that loops two, three or four threads together to create a stitch.

Your Baby Lock Ovation operates with one or two needles in the overlock position and one or two loopers to form an overlock stitch. Use one, two or three chain/cover stitch needles and one looper for a chain or cover stitch. Uniquely independent of each other, you can use any of the overlock or chain/cover stitch selections separately or in combination.

When fabric is placed in front of the presser foot, it reaches the feed dogs first. The feed dogs move the fabric along as the cutting blades trim the fabric edge, creating a clean edge to be finished. Or disengage your blade and insert the sewing table to sew a chain stitch in the center of your fabric.

The overlock stitch is supported by one or more parallel "stitch finger(s)" that keep the fabric flat. To form an overlock stitch, the threads become "locked" "over" the edge of the fabric encasing the raw edge with thread to prevent fabric raveling. When forming a chain stitch, the chain needle thread catches the chain looper to form a straight stitch on the top of your fabric and thread chain loops on the underside. Use 2 or 3 cover stitch needles and the chain looper to form a double or triple row of straight stitching on the top and a weave of thread on the underside of your fabric.

After setting up your machine for the first time, take a few moments to learn how it sews. Before your machine is threaded, turn the handwheel slowly toward you several times and watch the operation of the various parts.

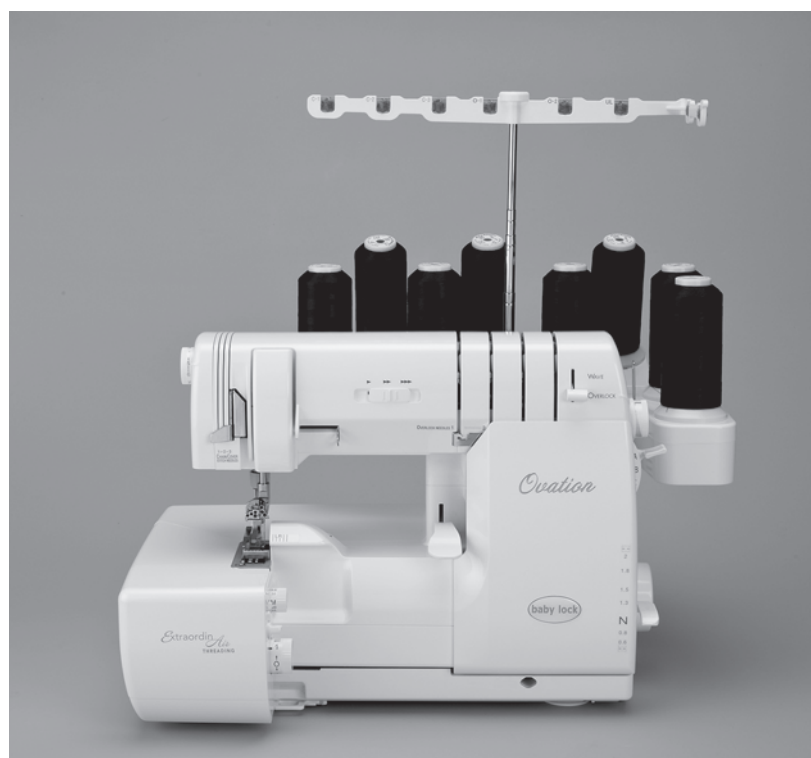

# Overview of the Ovation

1. Carrying handle
2. Chain/cover stitch needle tension dial
3. Presser foot pressure adjusting dial
4. Thread cutter
5. Quilting guide fixing screw
6. Presser foot release lever
7. Needle clamp
8. Needle height viewing area
9. Needle clamp screws
10. Snap-on presser foot
11. Needle plate
12. Upper blade
13. Stitch width adjusting dial
14. Side cover
15. Cutting blade locking dial
16. Stitch length/rolled hem adjusting dial
17. Cutting blade cover
18. Needle drop drawer
19. Front cover
20. Knee lifter slot
21. Threading lever
22. Bypassing thread guide
23. Differential feed adjusting lever
24. Handwheel
25. Foot control jack
26. Power cord receptacle
27. Power switch
28. Push to thread button
29. Chain looper threading port
30. Lower looper threading port
31. Upper looper threading port
32. Accessory compartment & thread stand
33. Stitch selector lever
34. Extension thread stand
35. Telescopic antennae and thread guides
36. Chain/cover stitch looper tension dial
37. Wave/Overlock Selector Lever
38. Upper & Lower looper thread fine-tuning knob
39. Presser foot thread release lever\*
40. Upper looper positioning knob
41. Sewing speed controller
42. Subsidiary looper

\* Raising the presser foot releases all threads.

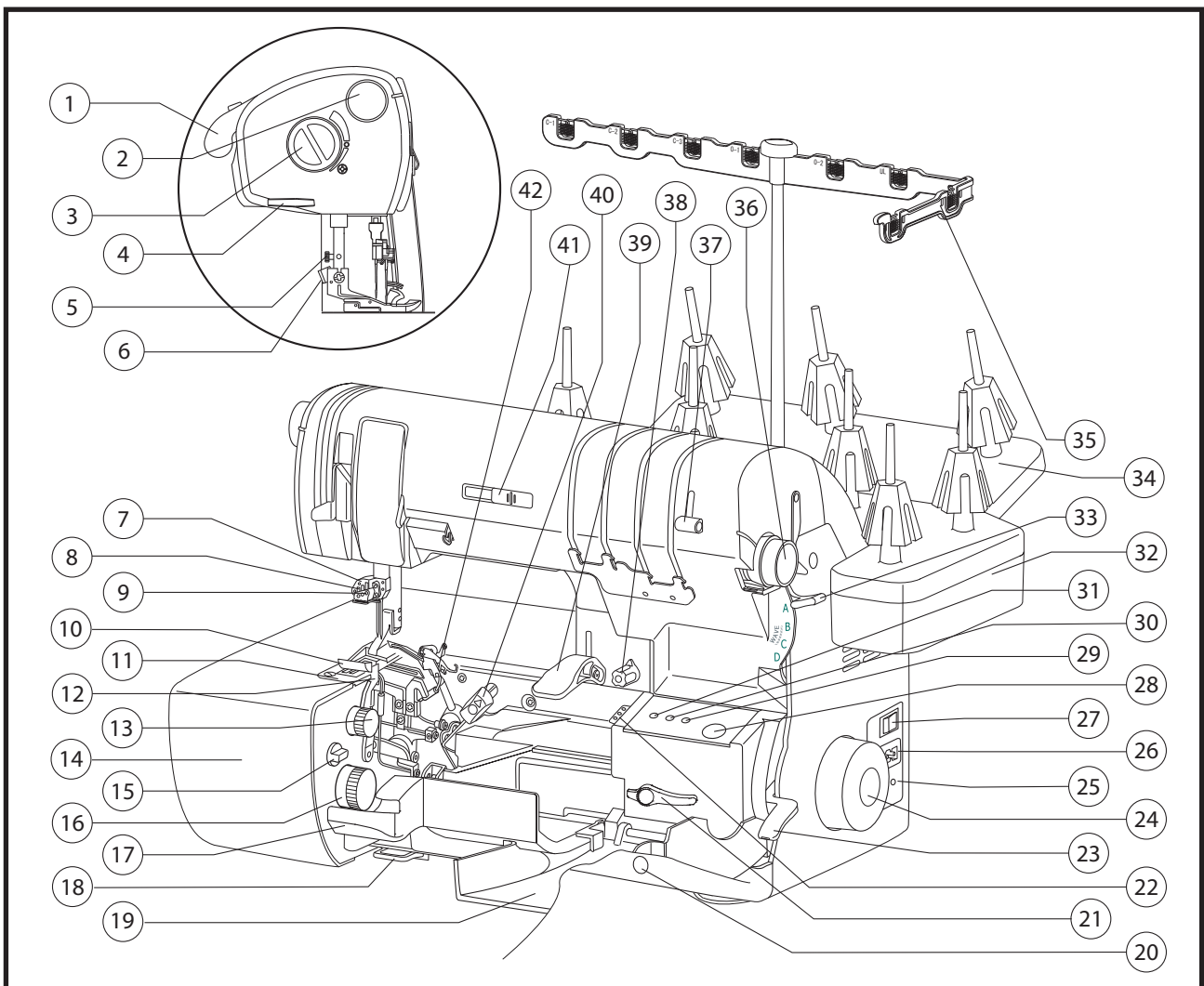

# Accessories

Your Baby Lock Ovation serger has a built-in accessory compartment. To open, grasp the backside of the compartment located under the lower and chain looper spool pins and slide toward the right to reveal the tray holding some of the accessories listed below. Others may be found in the machine packing materials.

| Accessory  | Number included | Located in            |
|--|-----------------|-----------------------|
| 1. Instruction manual                                  | 1               | Packing box           |
| 2. Quick reference threading guide                     | 1               | Packing box           |
| 3. Power cord  | 1               | Packing box           |
| 4. Foot control  | 1               | Packing box           |
| 5. Sewing table for chain/cover stitching              | 1               | Packing box           |
| 6. Guide fixing screws for sewing table                | 2               | With sewing table     |
| 7. Package of assorted sized needles<br>Organ ELx705CF | 1               | Accessory compartment |
| 8. Lint brush/needle insert tool                       | 1               | Accessory compartment |
| 9. Needle threader                                     | 1               | Accessory compartment |
| 10. Allen screwdriver                                  | 1               | Accessory compartment |
| 11. Tweezers   | 1               | Accessory compartment |
| 12. Upper cutting blade for replacement                | 1               | Accessory compartment |
| 13. Screwdriver  | 1               | Accessory packet      |
| 14. Looper threading tool                              | 1               | Accessory packet      |
| 15. Thread nets  | 8               | Accessory packet      |
| 16. Spool caps with sponge                             | 8               | Accessory packet      |
| 17. Spool caps   | 8               | Accessory packet      |
| 18. Machine cover                                      | 1               | Packing box           |
| 19. Mounting bolt with washer                          | 1               | Accessory packet      |
| 20. Spool pin disks (large)                            | 2               | Accessory packet      |
| 21. Cone holders                                       | 8               | On machine            |
| 22. Knee lifter  | 1               | Packing box           |

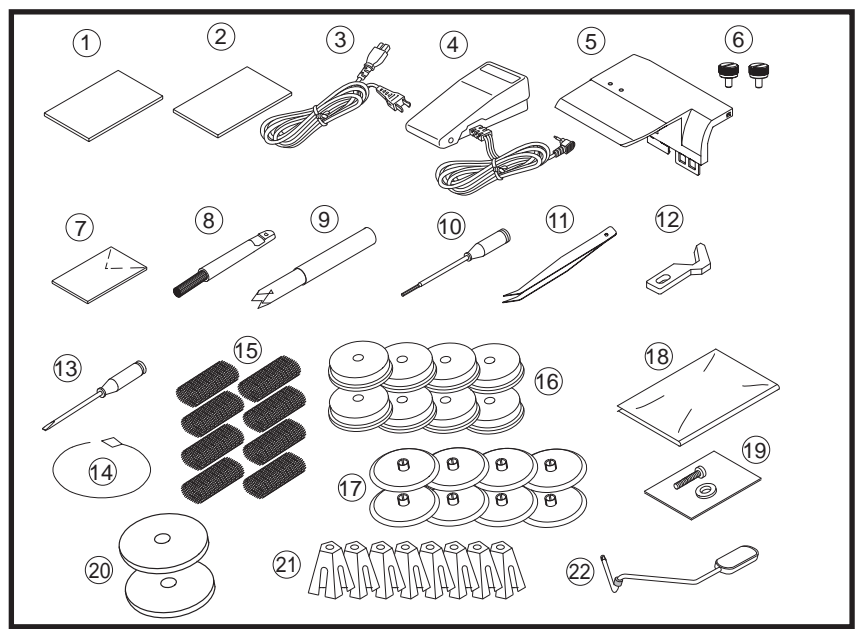
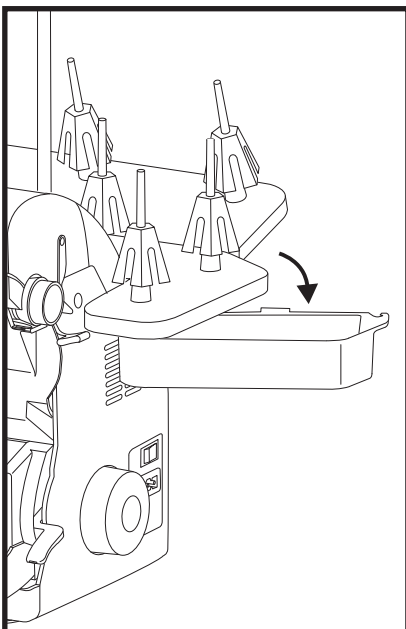

## Needles

Your Baby Lock Ovation serger is set up to use either Organ or Schmetz ELx705CF needles size 90/14. This is suitable for most medium and heavyweight fabrics. For lightweight fabrics use size 80/12, ELx705CF needles. The ELx705CF needle is a semi-ballpoint design and is suitable for knits and wovens.

## Thread

All types of thread may be used on your Baby Lock, but 100% polyester long fiber thread, crosswound on a cone, consistently provides the best stitch performance. Because the threads must pass through several thread guides at high speeds, they must be of uniform thickness and high strength while producing a minimum amount of lint.

Good quality cotton or cotton covered polyester threads sew well, though they produce more lint, creating the need to clean the machine more frequently. They work well for overedging and seaming, but they may be too weak or too fuzzy for the rolled edge. Poor grades of thread can result in frequent fraying, breaking and unbalanced stitches.

Threads of other fiber contents and weights may be used, depending on their strength and thickness. Testing will help you determine the stitch quality and how easily the threads can pass through the thread guides, thread slots, needles and loopers.

**Important Note:** For maximum performance of the Baby Lock Ovation, it is recommended to use "100% polyester long fiber thread". This thread also performs best when used with many decorative threads for sewing specialty decorative techniques.

## Optional Accessories

### OVERLOCK OPTIONAL ACCESSORIES

|                         |             |             |
|-------------------------|-------------|-------------|
| Beading Foot            | B5002-04A-C | (BLE8-BF)   |
| Blindhem Foot           | B5002S06A   | (BLE8-BLHF) |
| Elastic Applicator Foot | B5002S09A   | (BLE8-EF)   |
| Lace Applicator Foot    | B5002S08A   | (BLE8-LF)   |
| Piping/Cording Foot 5mm | B5002-05A-C | (BLE8-CF)   |
| Ruffling Foot           | B5002S07A   | (BLE8-RF)   |
| Clear Foot              | B5002S14A   | (BLE8-CLF)  |
| Curving Foot            | M0-36034    | (BLE8-CVF)  |

### CHAIN/COVER STITCH OPTIONAL ACCESSORIES

|                              |             |            |
|------------------------------|-------------|------------|
| Belt Loop Binder 3/4"        | B0421S12A   | (BLE8-S12) |
| Belt Loop Binder 1-1/2"      | B0421S11A   | (BLE8-S11) |
| Cover Chain Foot             | B5002S10B   | (BLE8-CCF) |
| Double Fold Bias Binder 28mm | B0421S03A   | (BLE8-S3)  |
| Double Fold Bias Binder 36mm | B0421S02A   | (BLE8-S2)  |
| Fabric Guide                 | M0-70A09    | (BLES8-FG) |
| Pintuck Foot w/2 Guides      | B5002-06A-C | (BLE8-PTF) |
| Plain Hemmer 1/4"            | B0421S07A   | (BLE8-S7)  |
| Plain Hemmer 1/2"            | B0421S06A   | (BLE8-S6)  |
| Single Downturn Feller 1/4"  | B0421S10A   | (BLE8-S10) |
| Single Downturn Feller 5/8"  | B0421S08A   | (BLE8-S8)  |
| Single Downturn Feller 1"    | B0421S09A   | (BLE8-S9)  |
| Single Fold Bias Binder 28mm | B0421S04A   | (BLE8-S4)  |
| Single Fold Bias Binder 40mm | B0421S05A   | (BLE8-S5)  |

### OTHER OPTIONAL ACCESSORIES

|                           |      |            |
|---------------------------|------|------------|
| Top Stitch Needle Size 90 |      | (T-90B)    |
| Trim bin                  | 900N | (BLTBIN)   |
| Quilt Guide               |      | (BLES8-QG) |

# Setting Up Your Ovation

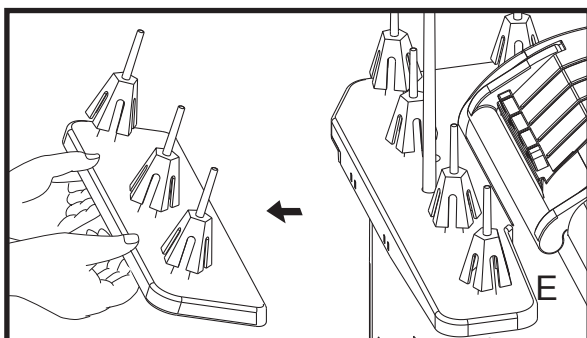
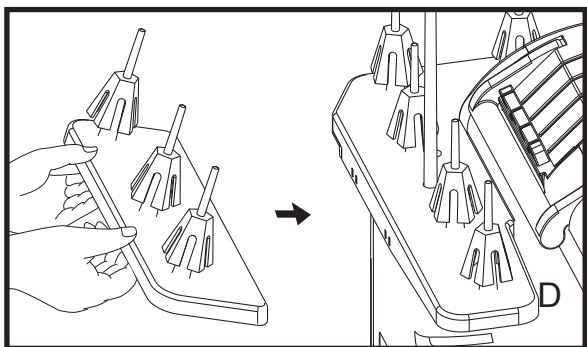
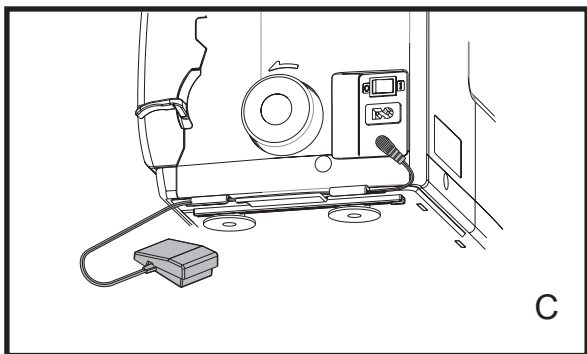
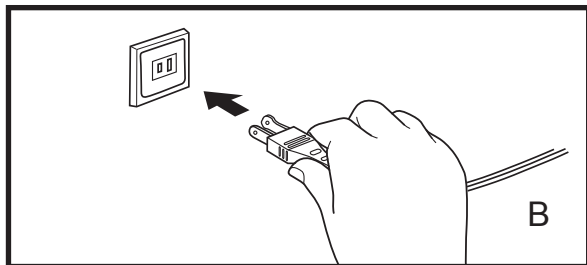
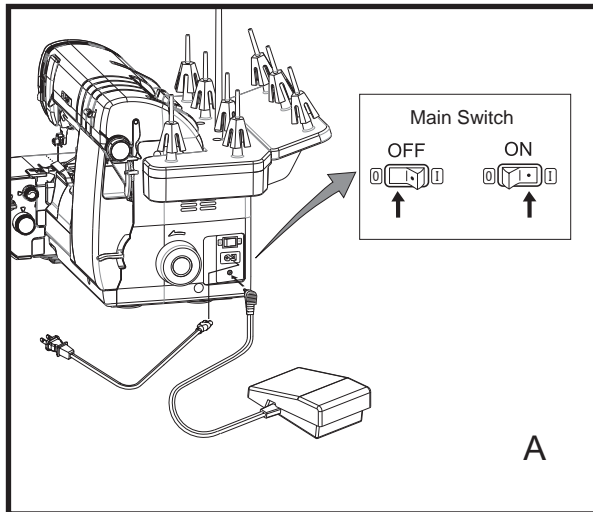

## 1. Remove machine from box

After removing the packing materials from the box, gently lift your Baby Lock serger by grasping the handle provided on the top of the machine. Place the machine on a serger sewing table or any sturdy level surface that provides ample work area to the left. Place the foot control in a pedal stay, if desired, and place it under the sewing table.

## 2. Plug in the machine

Before connecting the power supply, make sure the voltage and frequency shown on the machine conforms to your electrical power.

With the overlock machine turned off, insert the foot control jack and the power cord plug into their appointed connectors. (fig. A) Then plug the power cord into an electrical wall outlet.

Always make sure the power is off when the machine is not in use. (fig. A) Available foot control: Model YC-485EC or 4C-333C.

## 3. Polarized plug

This appliance has a polarized plug (one blade wider than the other). To reduce the risk of electric shock, this plug is intended to fit in a polarized outlet only one way. (fig. B) If the plug does not fit fully in the outlet, reverse the plug. If it still does not fit, contact a qualified electrician to install the proper outlet. Do not modify the plug in any way.

## 4. Foot controller

The sewing speed of the machine is determined by the amount of pressure applied to the foot controller. When not in use, do not place anything on the foot controller, or the machine could start inadvertently and the controller or motor could burn out.

Lay the foot control cord along the inside of the channel located on the bottom right side of the overlock machine. (fig. C)

## 5. Extension thread stand

To insert the extension thread stand:

Place the pegs into the slots on the back of the main thread stand.

Push the extension thread stand into the main thread stand until it snaps into place. (fig. D)

To remove:

Using both hands squeeze together the upper section of the stand support braces that are located just underneath the stand while gently raising it up and out to release from the main thread stand.

## Setting Up Your Ovation (Cont.)

### 6. Position the telescopic thread guide.

Raise the telescopic thread guide to its highest position. Rotate the shaft to the left and right until each section "clicks" into a locked position. (fig. F)

### 7. Opening front cover

The front cover may be opened simply by placing your fingers behind the cover at the upper right side and gently pull toward you. (fig. G)

### 8. Opening Cutting blade cover

To open the cutting blade cover, place your thumb against the tab, and slide the cover to the right. A slight pull toward you will allow the cover to swing down, providing access to the loopers, blades, and thread guides. (fig. H)

**Note:** The front cover has to be opened before opening the cutting blade cover.

Your machine is pre-set to sew an overlock with a chain stitch. The upper blade is engaged to cut the fabric while sewing. Of course, you may select to engage or disengage the cutting blade. You can change the blade cover to the sewing table and lock the upper looper down when sewing only the chain stitch.

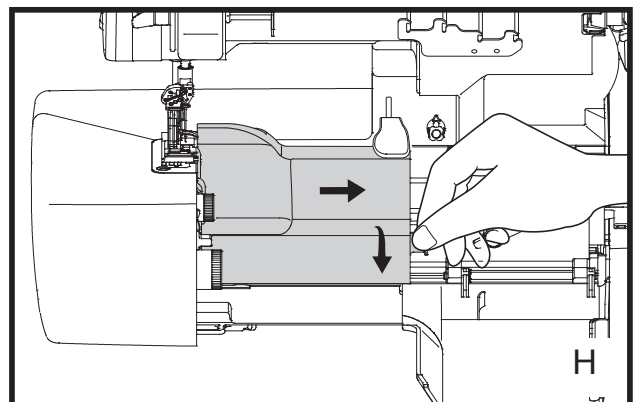
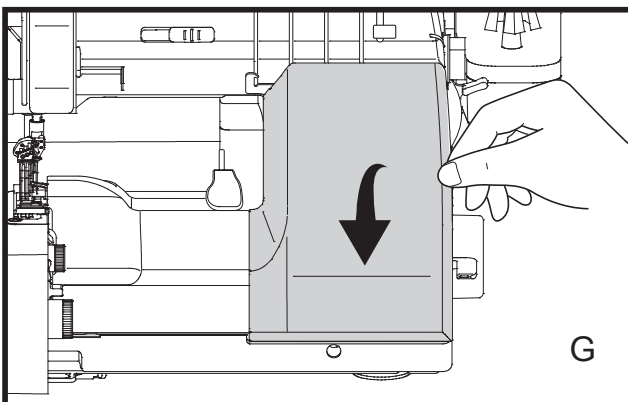
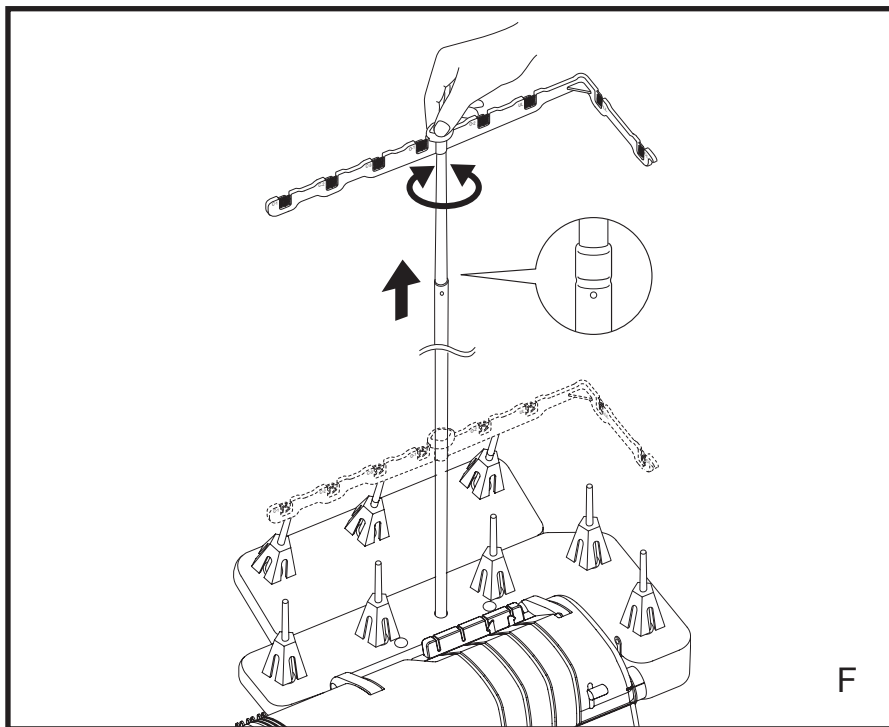

## Cutting Blade Locking Dial

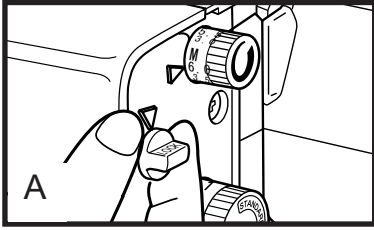

To lock cutting blade down:

Turn the dial clockwise 180 degrees until you see "LOCK" on the top.

The cutting blade will stay below the needle plate for non-cutting techniques. (fig. A)

To re-engage cutting blade:

Turn the cutting blade locking dial half of a turn counter-clockwise. The blade will start moving automatically when you start sewing.

## Upper Looper Positioning Knob

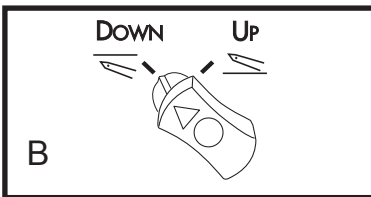

When you change from overlocking to chain/cover stitching, you should also disengage the upper looper by changing the upper looper positioning knob to the "DOWN" position before you close the sewing table door.

a) Turn the handwheel until upper looper is at its lowest position.

b) Change the upper looper positioning knob to the "DOWN" position. (fig. B)

c) Close the sewing table door and then the front cover. (fig. C)

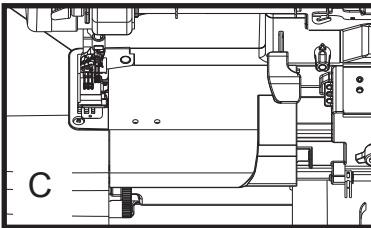

**Note:** Make sure the upper looper positioning knob is in the "UP" position prior to locking the machine to thread the upper looper.

## Cutting Blade Cover and Sewing Table

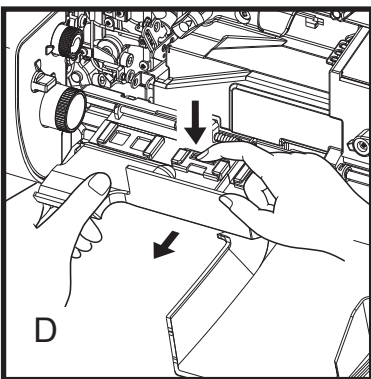

To use the sewing table for chain/cover stitching you will need to change the cutting blade cover as follows:

a) Open front cover and cutting blade cover. (page 9, fig. G & H)

b) Depress the center snap and gently pull toward you to unsnap blade cover (fig. D) and then snap sewing table into place. (fig. E)

c) Disengage the upper looper by turning the upper looper positioning knob to "Down". (fig. B)

d) Move the stitch width adjusting dial to the 3.0 setting.

e) To close the sewing table door raise to the up position and slide to the left placing the tab of the table under the needle plate. (fig. E)

f) Close the front cover.

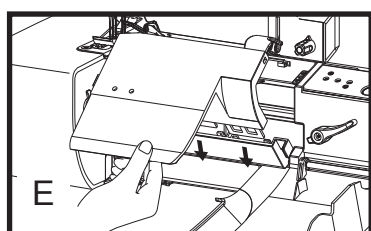

**Note:** Even though you are not using your cutting blade with the sewing table, the adjusting dial needs to be moved to its lowest setting for the table to fit against the needle plate.

# Thread Cutter

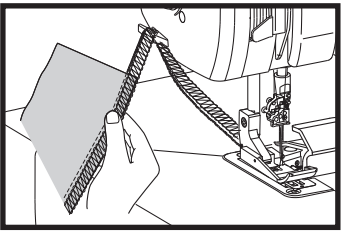

There is a thread cutter located on the left side of your Ovation. At the end of a seam, sew off the fabric edge and continue sewing to create a 5-6 inch (12.5-15cm) thread chain. Bring the chain of thread up and from the back to front through the thread cutter.

# Presser Foot Pressure Adjustment

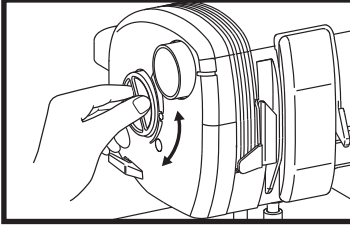

The presser foot pressure has been preset at the factory and rarely needs adjustment. You may find it necessary, however, to decrease the pressure for thick fabrics or increase pressure for thin fabrics to feed more smoothly under the foot. Turn the adjusting dial on left side of the machine.  
 To increase pressure, turn the pressure adjusting dial counterclockwise.  
 To decrease pressure, turn the dial clockwise.

# Snap-On Presser Foot

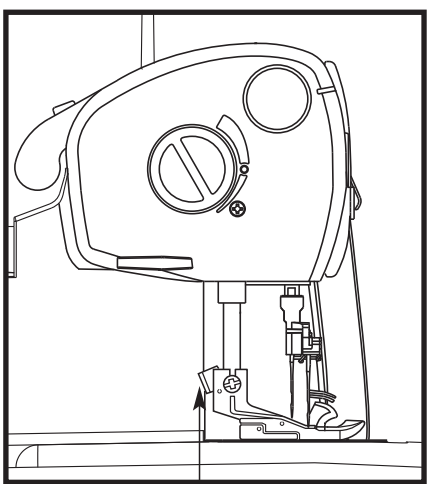

Presser Foot Release Lever

The Ovation has the convenience of a snap-on presser foot system.

**To Release:**

1. Raise the presser foot thread release lever to highest position.
2. Lock the cutting blade down.
3. Raise the needles to their highest position.
4. Push the presser foot release lever located at the back of the presser foot holder.
5. Slide presser foot slightly toward you and carefully turn the back section of foot clockwise 90 degrees.
6. Slide the presser foot to the rear to remove.

**To Replace:**

1. Raise the presser foot thread release lever.
2. Lock the cutting blade down.
3. Raise the needles to the highest position.
4. Slide the foot from the left to right.
5. Align the bar of the foot with the groove in the holder.
6. Lower the presser foot thread release lever to snap into place.

The presser foot that comes with the Ovation has three separate tape slots located on the front section of the foot. Insert the tape or ribbon through the appropriate slot and then under the sole of the foot. (see page 70 for detailed instructions)  
 The raised markings on the toe of the foot are seam line guides. They indicate the needle positions to help guide your fabric for accurate seaming.

## Stitch Length/Rolled Hem

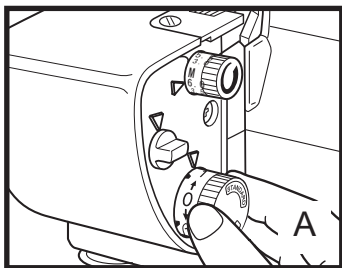

The stitch length / rolled hem adjusting dial is conveniently located just to the left of the cutting blade cover, near the base plate. (fig. A) The dial shows two stitch-length ranges, from 0.75, for the shortest stitch, to 4 for the longest. As the dial indicates, one range is for standard sewing and one is for rolled edging or narrow seaming.

Simply turn the dial aligning the desired setting with the indicator mark on the machine. A stitch length of 3mm, or about 10 stitches per inch is ideal for seaming and overedging most fabrics. For overedging or seaming very lightweight fabrics, you may prefer a shorter stitch length. When sewing heavier fabrics, you may choose to lengthen the stitch. (fig. B)

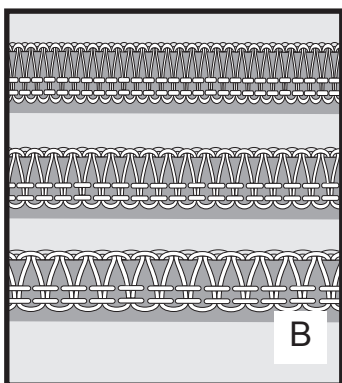

**Note:** 0.75mm is located between the 0 and 1 on both standard & rolled hem settings.

## Stitch Width

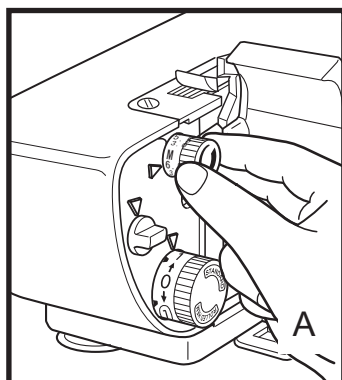

The stitch width adjusting dial is located above the stitch length dial. (fig. A) The stitch width displays two sets of numbers, indicating two width ranges, for overlock stitches. The larger size numbers on the dial, 5.5 through 7.5mm, denote the stitch width when the 0-1 (left) needle is in use. The smaller size numbers, 3.0 through 5.0mm, apply when only the 0-2 (right) needle is in use for forming a 3-thread stitch. The "M" setting (3.5) is for the rolled edge.

Adjusting the stitch width moves the upper cutting blade. It also moves the stitch fingers further apart or closer together for complete fabric support with any stitch width.

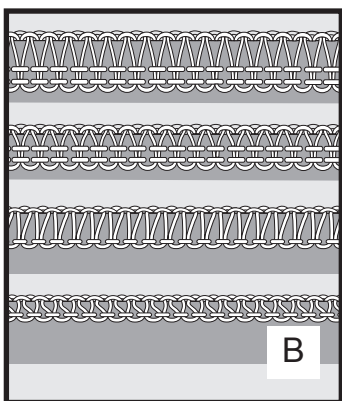

The stitch width is infinitely variable between either end of the range. Simply turn the dial aligning the desired setting with the indicator mark on the machine. Use a wider stitch on loosely woven fabrics. You may prefer a narrower stitch width on knits, tightly woven, or sheer fabrics. (fig. B)

# Differential Feed

Your Baby Lock serger is equipped with differential feed. The set of feed dogs work independently in order to ensure smooth sewing on all fabrics.

When the differential feed adjusting lever, located at the machine's right front edge, is set on "N" for normal feeding, the feed dogs move the same distance. This is the setting to use for most fabrics and applications.

When the dial is set above "N" (fig. B), the front feed dog will feed more fabrics than the back. This is because the front feed dog moves at a greater distance than the back feed dog. As a result, the fabric becomes compressed or eased, as the diagram on the front cover indicates. This can eliminate wavy seams in stretchy fabrics or those cut on the bias grain. (fig. A)

At the maximum setting of 2 (fig. C), the differential feed can gather a lightweight fabric to nearly double fullness. (fig. D) The front feed dog is actually feeding in twice as much fabric as the back feed dog is feeding out. To maximize the gathering effects, use the longest stitch length setting. Fabric weight will affect the gathering. Test stitch for desired results.

When the differential feed lever is set below "N" (fig. F), the front feed dog moves less distance than the back feed dog. This adjustment stretches the fabric slightly as it is sewn. The lower settings prevent puckers on lightweight fabric (fig. E), add more stretch to swim wear, active wear, and can be used to create a lettuce edge. (see page 33)

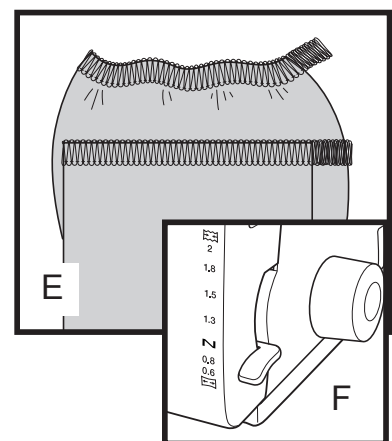
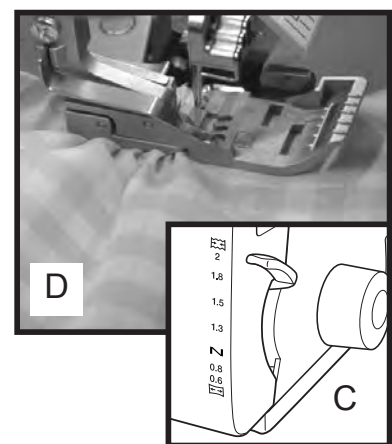
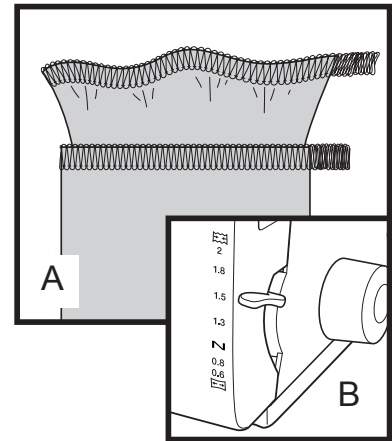

# Overlock Thread Delivery System

The Baby Lock Ovation revolutionizes the way a serger works with its exclusive overlock Thread Delivery System. You no longer have to manually adjust the tension settings for the type of overlock stitch you are sewing. Select the type of overlock stitch you wish to serge, the Ovation will automatically feed the correct amount of thread through the needles, the loopers and thread guides to form a perfect stitch every time.

## Stitch Selector Lever

The stitch selector lever, which controls the overlock thread delivery system for overlock stitching, is located on the right side of the machine. Select appropriate setting: A, B, C, or D.

- A - for overlock stitches using the left needle (O-1) and the looper threads balanced.
- B - for overlock stitches using the right needle (O-2) and the looper threads balanced.
- C - for narrow stitches with a short length and the looper threads balanced.
- D - for stitches that require a tight lower looper.  
For best results, use setting B or C for WAVE stitching.  
See chart on last two pages for stitch selection settings.

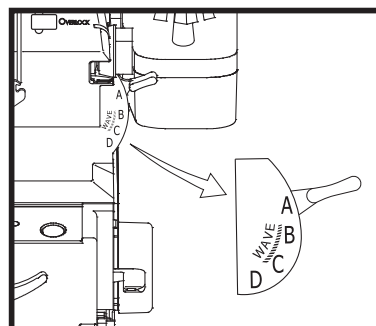
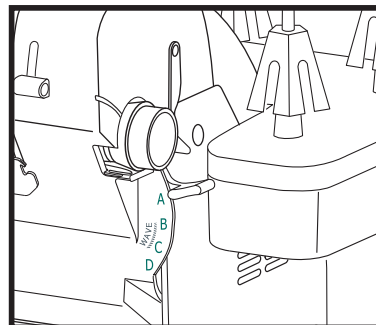

## Wave/Overlock Selector Lever

The Wave/Overlock Selector lever shows "OVERLOCK" and "WAVE". Select "OVERLOCK" for overlock stitching. Select "WAVE" for wave stitching

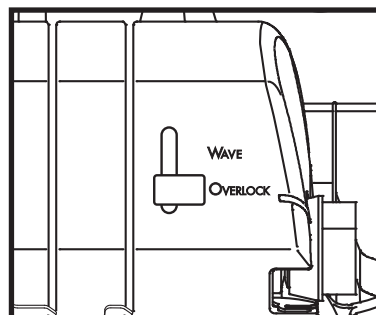

## Side Cover

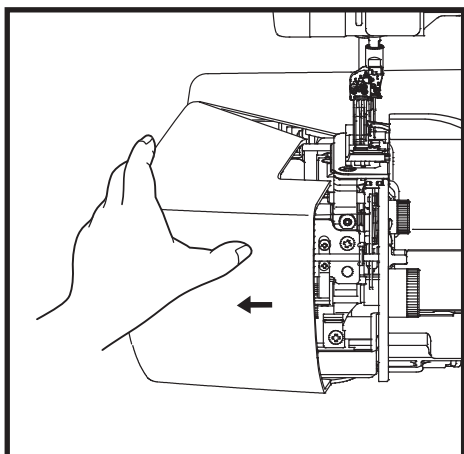

Open side door on the left for easy access to the chain looper thread tray.  
Close door before sewing.

## Chain/Cover Stitch Tension Dials

The tension system of the chain and cover stitches are completely separate from the system being used on the overlock stitches. Unlike the thread delivery system of the overlock stitches, the tensions of the chain / cover stitch needles and chain looper are adjusted by dials located on the outer sides of your Ovation.

### Chain/Cover Stitch Needle Tension Dial

The chain/cover stitch needle tension dial is located on the left upper side of the machine. One tension dial controls all 3 of the chain/cover stitch needle selections. Normally set at "5", the dial can be turned from 0 - 9 to increase or decrease the tension on the chain/cover stitch needle threads.

Increase the tension by turning the dial to a larger number.

Decrease the tension by turning the dial to a smaller number.

Align the number with the indicator mark on the front of the machine near the dial.

### Chain/Cover Stitch Looper Tension Dial

The chain/cover stitch looper tension dial is divided into 2 sections - Chain Stitch and Cover Stitch. The dial is located on the right upper side of the machine. Align the selected tension setting with the indicator mark on the front right of the machine.

The Chain Stitch section of the looper tension dial has a tighter looper tension for sewing chain stitch. Select from the row of stripes on the dial for chain stitching. The wider the stripe the tighter the chain looper tension.

The Cover Stitch section of the looper tension dial has a looser tension for sewing wide, narrow or triple cover stitches. Select the solid line on the dial for cover stitch tension settings. The closer the dial is moved to the wide horizontal mark indicates looser tension for cover stitching.

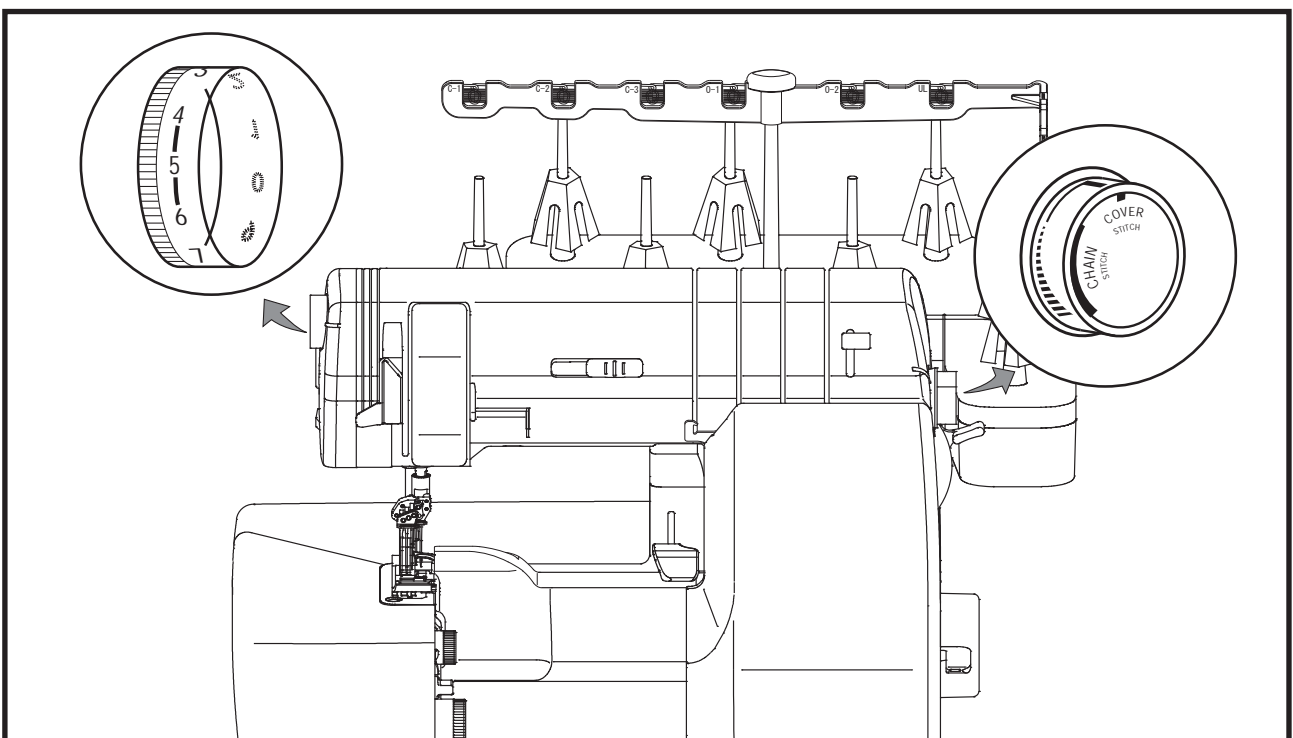

## 2-Thread Subsidiary Looper

Either needle thread may be engaged for 2-thread overlock sewing.

1. Open the front cover and the blade cover, cut the upper looper thread just above the threading port. (fig. A) Raise the presser foot and pull out the clipped thread from under the foot.  
Remove the upper looper thread from the machine.
2. Rotate the handwheel to bring the upper looper to its highest position.
3. Rotate the subsidiary looper up and to the left (fig. B), insert the end into the upper looper eye. (fig. C)
4. Close the blade cover and the front cover.

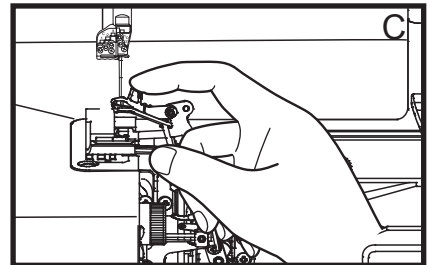
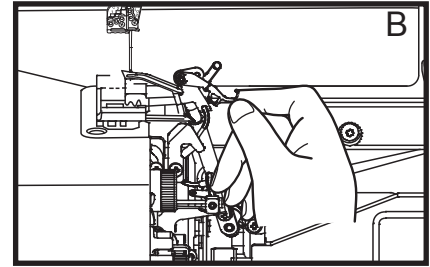
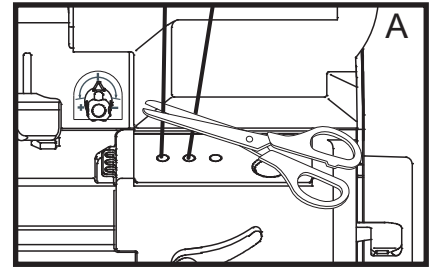

## Upper and Lower Looper Thread Fine-Tuning Knob

No adjustments are needed when sewing with most fabrics and threads on your Baby Lock Ovation, but certain threads or fabrics may require minor fine-tuning of the looper delivery system to perfect your stitches. Increase or decrease the delivery of the looper threads with the upper and lower looper thread fine-tuning knob. With your finger tips, turn the fine-tuning knob counterclockwise to tighten the looper threads equally. Turn the knob clockwise to loosen the looper threads equally.

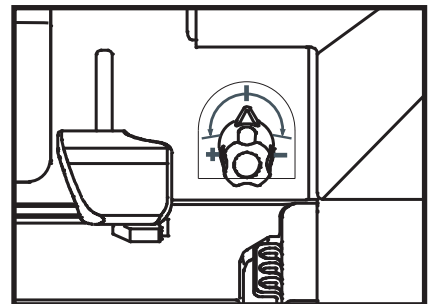

Ideal Stitch

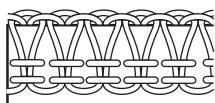

Standard Position

Upper and lower looper threads are too loose.



Tighten the tension(+)

Upper and lower looper threads are too tight.

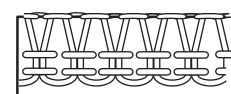

Loosen the tension (-)

## Sewing Speed Controller

Your Baby Lock Ovation is equipped with a sewing speed controller.

The machine will sew faster with the foot control fully depressed when the controller is moved to the right and will sew slower when the controller is moved to the left.

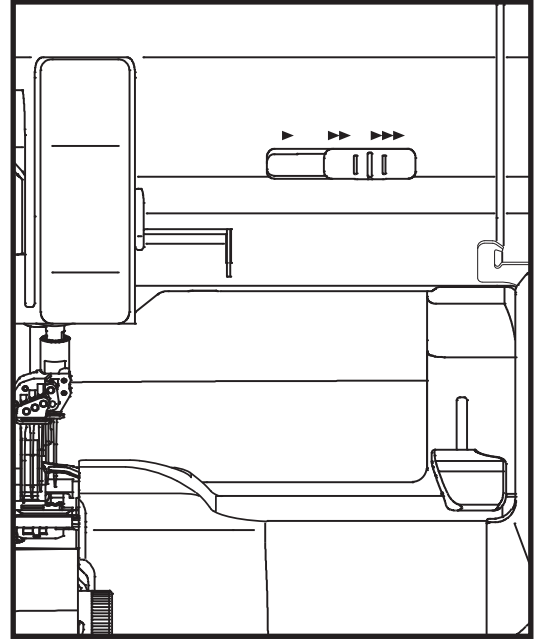

## Knee Lifter

Your Baby Lock Ovation comes equipped with a knee lifter.

Using your knee, the presser foot can easily be raised and lowered; leaving both hands free to manipulate the fabric.

Align the tabs on the knee lifter with the notches in the jack, and then insert the knee lifter by pushing it toward the machine until it clicks into place. The black "Knee lifter front cover protector" should be positioned as shown in the below illustration.

To remove the knee lifter place left hand on the front cover to secure and with right hand pull knee lifter straight out.

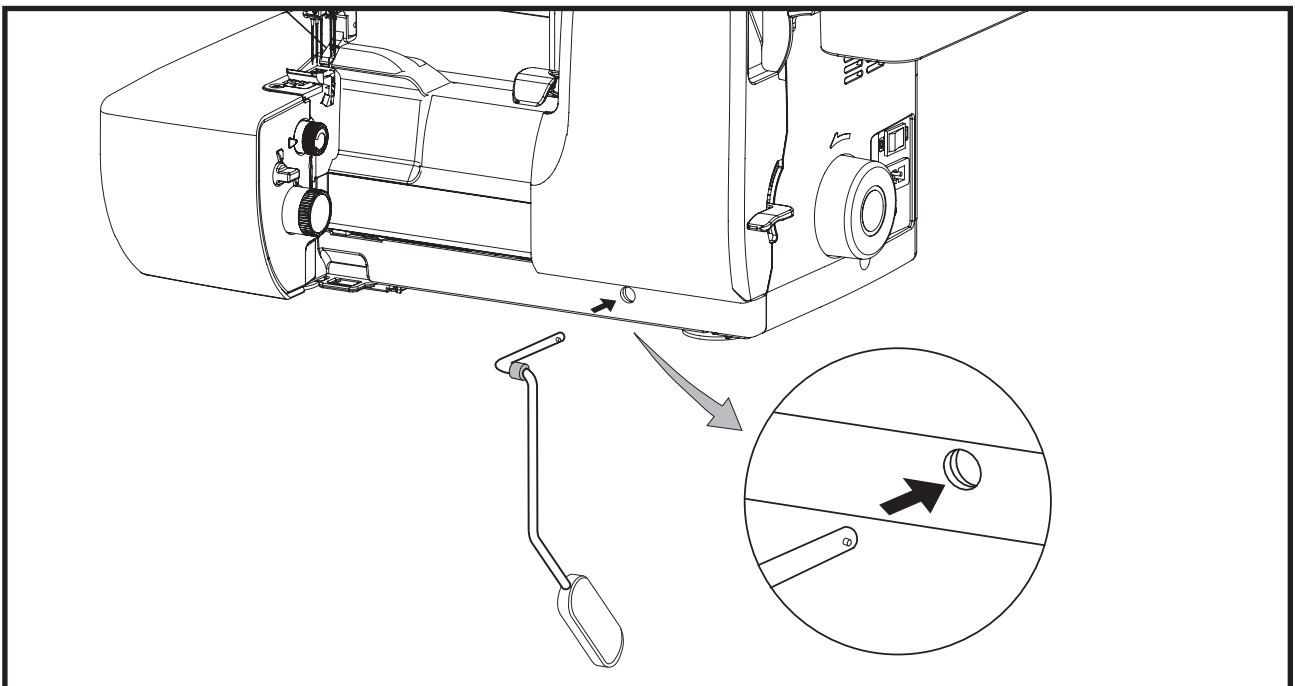

# Threading Preparation

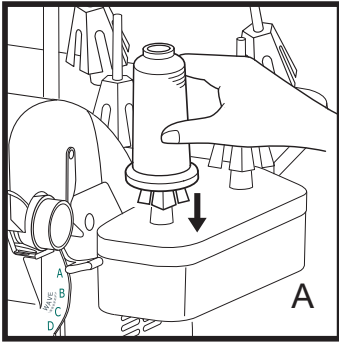

Large spools with Cone Holders.

When using threads on cones or king spools place the cone or spool securely over the cone holders furnished on your machine. To avoid bending the thread stand, you may need to place one hand under the stand while positioning the cone. The cone holders prevent the cone or spool from spinning, enabling the thread to feed evenly. (fig.A)

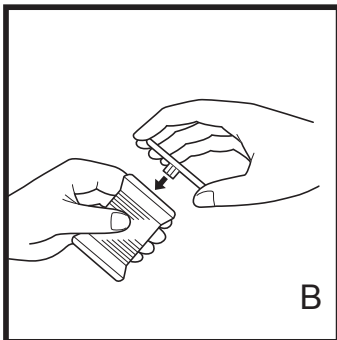

Standard sewing thread with spool cap.

Because threads for the serger feed from the top, standard spool threads can snag on the rough edges of many of these spools. That's why spool caps are furnished with your serger to provide a smooth surface that enables the thread to flow freely. With the spool notch side down, insert a spool cap into the top of the spool. (fig.B)

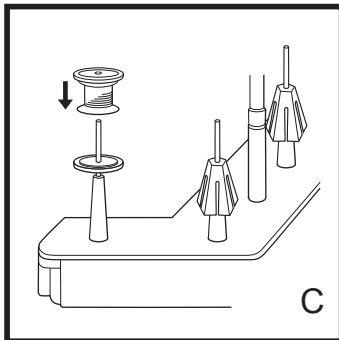

Standard sewing thread with spool cap with sponge and spool cap.

When using standard spool threads on your serger, replace the cone holders with the spool caps with sponge furnished with your machine. These caps hold smaller spools securely and help the thread to flow properly. With the spool cap with sponge in place, put the capped spool on the spindle. (fig.C)

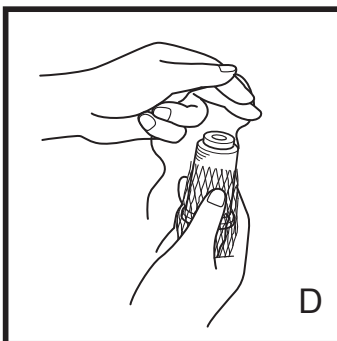

Thread net on thread.

Thread nets may be placed over threads that tend to slip off the bottom of the spool during sewing. Most threads do not require their use, but nets often are necessary with nylon, rayon or silk threads (fig.D). Once it's on the spool, fold the net back on itself. Pull thread

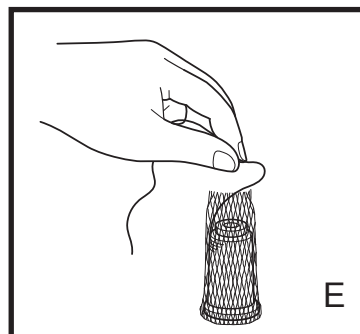

Pulling thread through thread net.

from the top of spool to enable the thread to feed evenly. (fig.E)

# Threading Your Ovation

Your Baby Lock Ovation is equipped with an exclusive "Electronic Extraordin Air Threading System" for fast, easy threading of the upper, lower, and chain loopers. One touch of the "Push to Thread" button will automatically thread the loopers. It is no longer necessary to use tweezers for threading the loopers. If a looper thread breaks or runs out, just re-thread it. There is no need to follow a specific threading sequence.

## Threading Position for Threading, Thread Stand and Thread Port Reference Chart

1. Open the front cover.
2. Raise the presser foot to release all threads.
3. Set the threading lever from serging position to threading position. (fig.A)
4. Rotate the machine handwheel slowly toward you until the tubes move to the connecting position. (fig. B)

**Note:** The Ovation must be in the locked threading position when threading the loopers unless otherwise indicated.

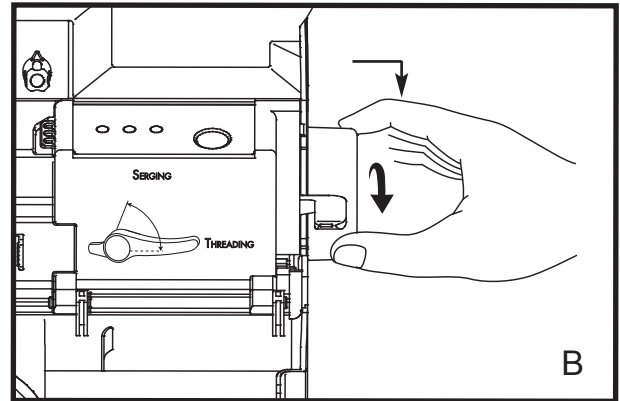
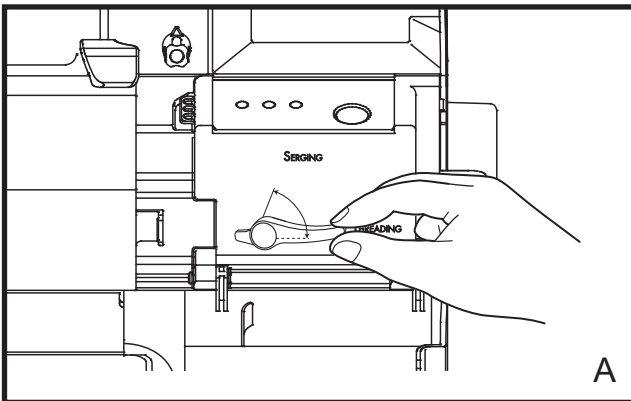

The antennae thread guides, base of thread stands and threading ports are color coded for your convenience.

All gold color labels relate to threading for chain and cover stitches.

All green color labels relate to threading for overlock stitches.

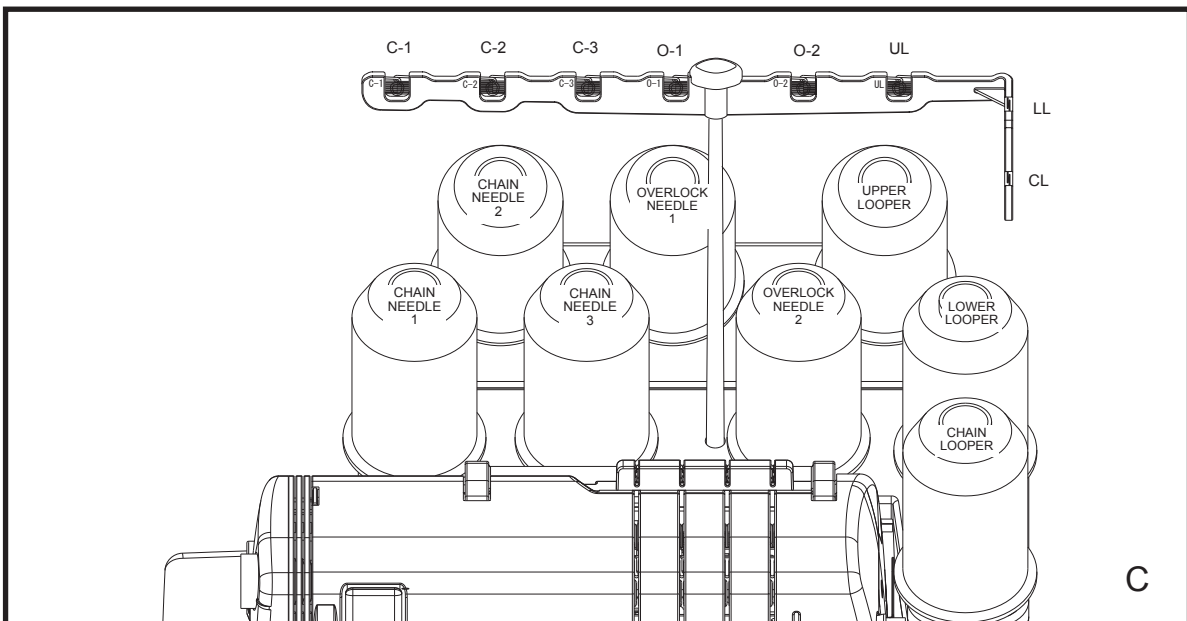

## Lower Looper

1. Raise the presser foot and move the threading lever to the threading position. (see page 19, fig. A)
2. Place the thread cone or spool on the "LOWER LOOPER" spool pin on the thread stand. Glide the lower looper thread through the telescopic antennae thread guide "LL" directly above the thread spool. (see page 19, fig. C) Snap the thread into the pretension thread guide on the top of the machine and through the slot above the front cover. (fig. A)
3. Pull 22 inches (56cm) of thread through guide and slot. Insert the end of the thread into the threading port "L" about 1/2 inch (1.2cm). Use tweezers, if necessary, to insert the thread end more easily. (see page 21, fig. E for example of port threading)
4. Press the "Push to Thread" button. (see page 21, fig. E for example of port threading) If the thread does not go through the eye of the lower looper with one push, push the threading button again until it does.
5. Clip the thread 4 inches (10cm) from the eye of the lower looper and leave it hanging loose inside the machine.
6. Once machine is completely threaded for chosen serging application set the threading lever to serging position.

## Upper Looper

1. Set the upper looper positioning knob to "UP" position. (fig. B)
2. Raise the presser foot and move the threading lever to the threading position. (see page 19, fig. A)
3. Place the thread on the "UPPER LOOPER" spool pin on the thread stand. Glide the upper looper thread through the telescopic antennae thread guide "UL" directly above the thread spool. (see page 19, fig. C) Snap the thread into the pretension thread guide on the top of the machine and through the slot above the front cover. (fig. A)
4. Pull 22 inches (56cm) of thread through guide and slot. Insert the end of the thread into the threading port "U", about 1/2 inch (1.2cm). Use tweezers, if necessary, to insert the thread end more easily. (see page 21, fig. E for example of port threading)
5. Press the "Push to Thread" button. (see page 21, fig. E) If the thread does not go through the eye of the upper looper with one push, push the threading button again until it does, then pull thread toward rear of machine and place under presser foot.
6. Once machine is completely threaded for chosen serging application set the threading lever to serging position.

**Note:** Make sure that the upper looper positioning knob is always set in the "UP" position whenever you are threading the "eye" of the upper looper. (fig. B)

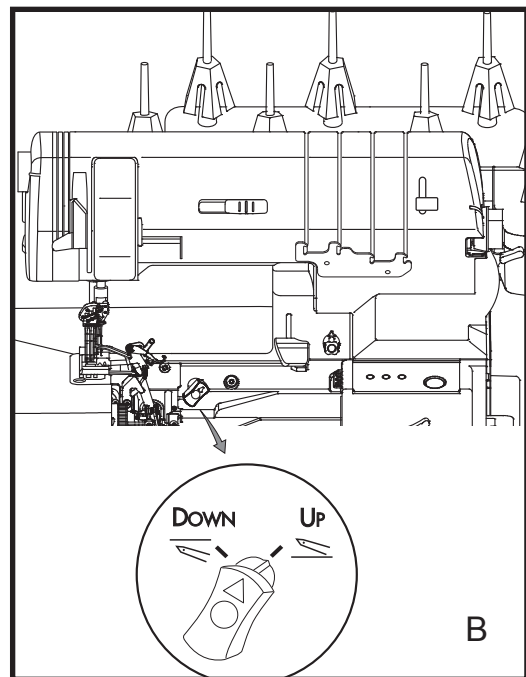
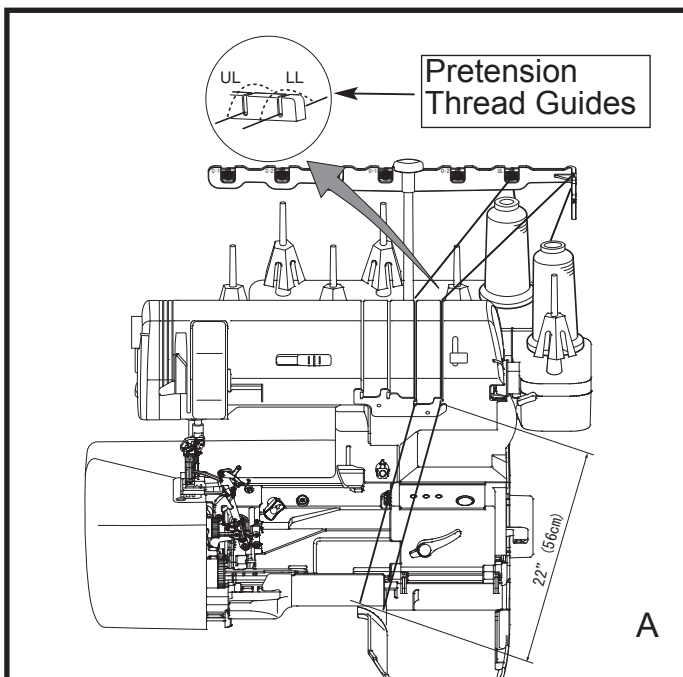

# Chain Looper

1. With the presser foot in the raised position, open the front cover and move the threading lever into the threading position. (see page 19, fig. A)
2. Set the stitch selector lever to "D" position for easy threading of the chain looper tension dial.
3. Place the thread cone or spool on the "Chain Looper" spool pin. Glide the chain looper thread through the telescopic antennae thread guide "CL" directly above the thread spool. (see page 19, fig. C)
4. Insert the thread through the guide above the chain looper tension dial from right to left. Bring the thread to the back and under the thread guide, then up and over the tension dial. (fig. D inset)
5. Slip thread into guide on front of dial, then down to the chain looper threading port.
6. Pull 22 inches (56cm) of thread and insert 1/2 inch (1.2cm) of thread into the chain looper threading port. Use tweezers if necessary, to insert the thread end. (fig. E)
7. Press the "Push to Thread" button. (fig. E) If the thread does not go through the eye of the chain looper with one push, push the threading button again until it does.
8. Open side cover to the left for easy access to the chain looper thread in tray. ( fig. F)
9. Trim excess thread to 4 inches (10cm) from the eye of chain looper and lay thread back inside the tray.
10. Close side cover.
11. Once machine is completely threaded for chosen serging application set the threading lever to serging position.

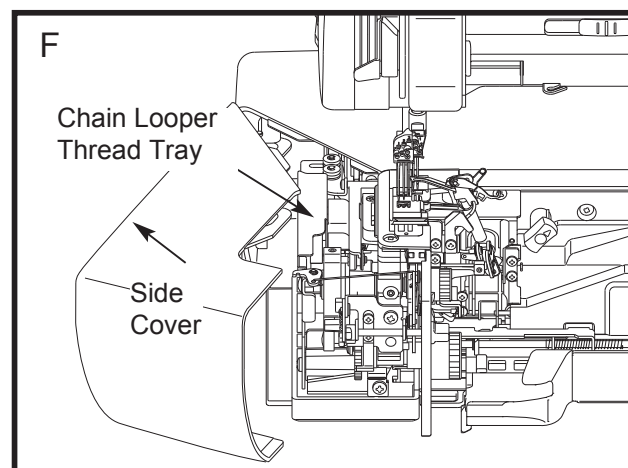
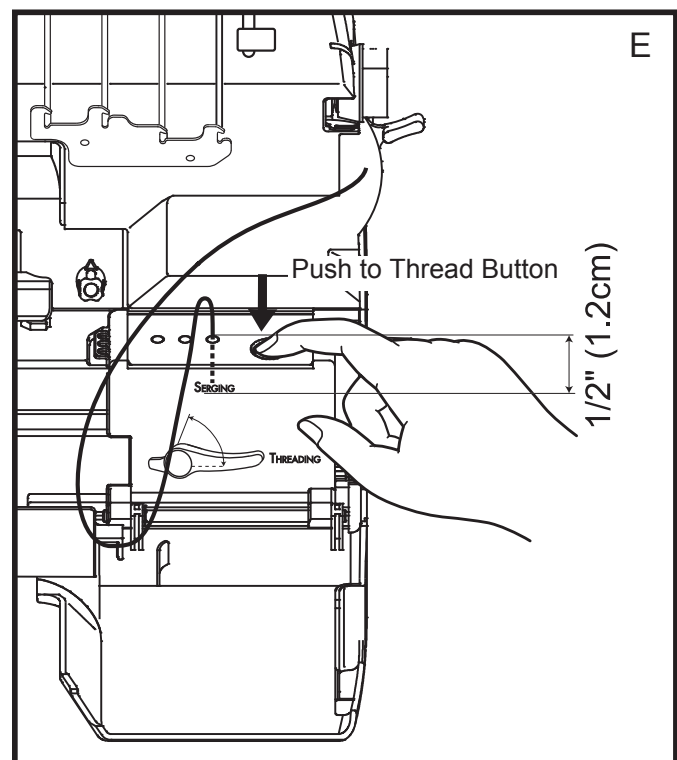
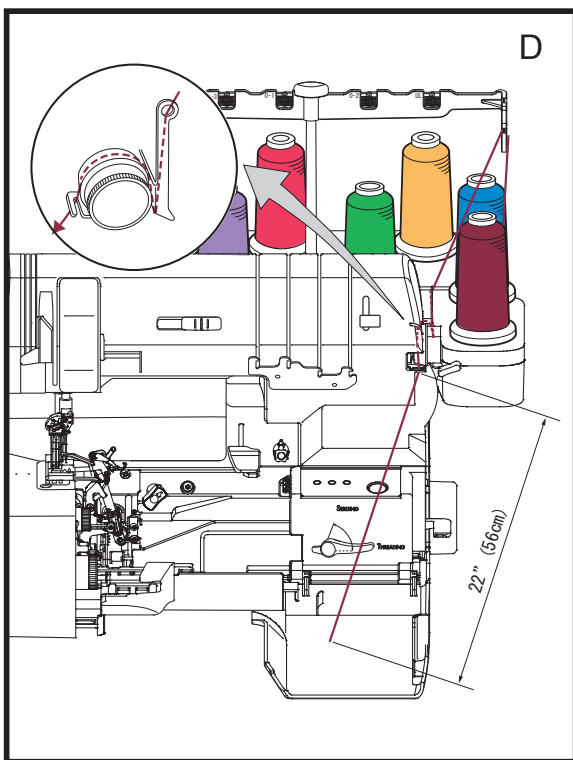

# Chain / Cover Needles

## Left Chain/Cover Needle C-1

1. Raise presser foot, place the thread on the "Chain Needle 1" spool pin. Glide the thread through the telescopic antennae thread guide "C-1" directly above the thread spool.  
See drawings below for reference.
2. Bring thread down from the telescopic antennae thread guide and going from left to right place into the far left chain/cover needle thread guide "C1"; inserting the thread into slot until it clicks into place. This seats the thread into the tension. Bring the thread behind the front thread guide, up, over and down the right side of the thread take up lever.
3. Insert "C-1" thread into the thread guide on needle clamp just above the needle. See drawings below for reference.
4. With the needle threader or tweezers in the accessory compartment, thread needle in "C1" position.

## Center Chain/Cover Needle C-2

1. Raise presser foot, place the thread on the "Chain Needle 2" spool pin. Glide the thread through the telescopic antennae thread guide "C-2" directly above the thread spool.  
See drawings below for reference.
2. Bring thread down from the telescopic antennae thread guide and going from right to left place into the center chain/cover needle thread guide "C2"; inserting the thread into slot until it clicks into place. This seats the thread into the tension. Bring the thread behind the front thread guide, up, over and down the right side of the thread take up lever.
3. Insert "C-2" thread into the thread guide on needle clamp just above the needle. See drawings below for reference.
4. With the needle threader or tweezers in the accessory compartment, thread needle in "C2" position.

## Right Chain/Cover Needle C-3

1. Raise presser foot, place the thread on the "Chain Needle 3" spool pin. Glide the thread through the telescopic antennae thread guide "C-3" directly above the thread spool.  
See drawings below for reference.
2. Bring thread down from the telescopic antennae thread guide and going from right to left place into the far right chain/cover needle thread guide "C3"; inserting the thread into slot until it clicks into place. This seats the thread into the tension. Bring the thread behind the front thread guide, up, over and down the right side of the thread take up lever.
3. Insert "C-3" thread into the thread guide on needle clamp just above the needle. See drawings below for reference.
4. With the needle threader or tweezers in the accessory compartment, thread needle in "C3" position.

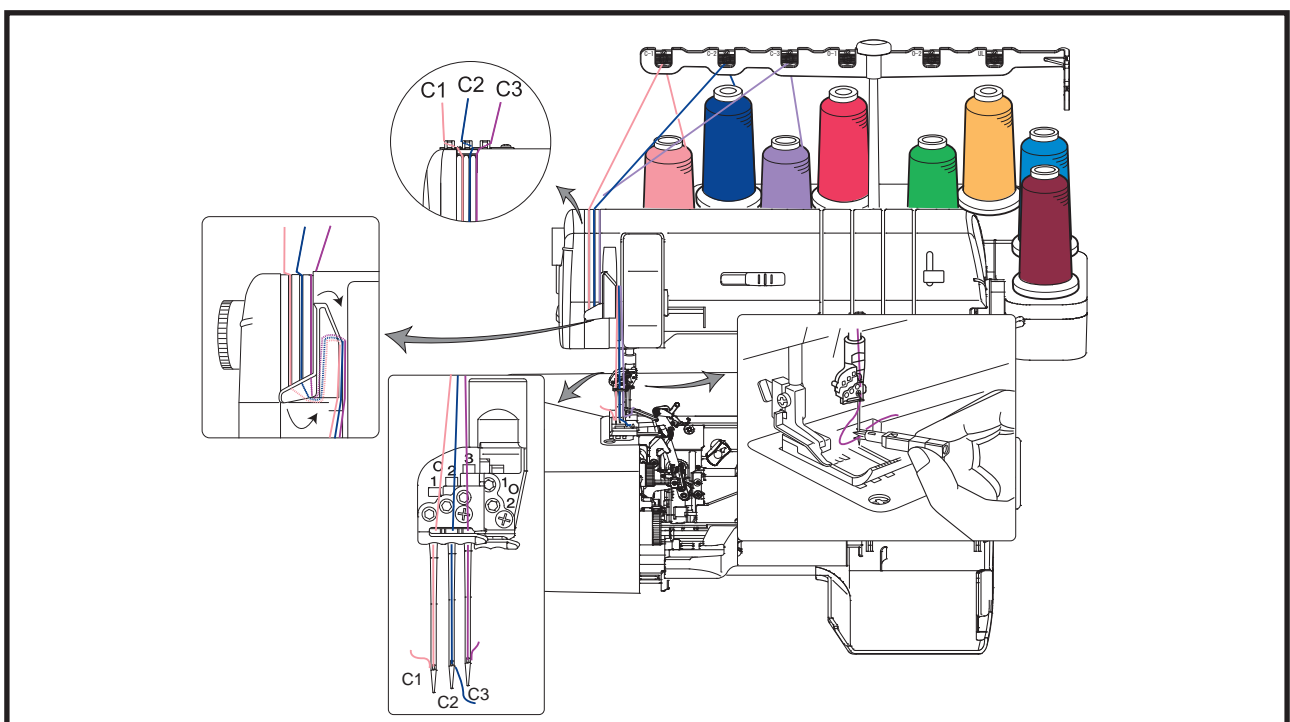

# Overlock Needles

## Left Overlock Needle O-1

1. Place the thread cone or spool on the "OVERLOCK NEEDLE 1" spool pin. (see page 19, fig. C) Glide the thread through the telescopic antennae thread guide "O-1" directly above the thread spool. Snap the thread into the pretension thread guide on top of machine and down the "overlock needle 1" thread path and in the guide just below the faceplate. Pull an 8 inch (20.5cm) length of thread through the guide. Follow the arrows as shown in below illustration. Thread the overlock thread guide above the needle.
2. Using the needle threader or tweezers, thread needle in the O-1 position.

## Right Overlock Needle O-2

1. Place the thread cone or spool on the "OVERLOCK NEEDLE 2" spool pin. (see page 19, fig. C) Glide the thread through the telescopic antennae thread guide "O-2" directly above the thread spool. Snap the thread into the pretension thread guide on top of machine and down the "overlock needle 2" thread path and in the guide just below the faceplate. Pull an 8 inch (20.5cm) length of thread through the guide. Follow the arrows as shown in below illustration. Thread the overlock thread guide above the needle.
2. Using the needle threader or tweezers, thread the needle in the O-2 position.

**Note:** Make sure that each needle is in the overlock needle position; right needle is O-2 and left needle is O-1 as shown in below illustration..

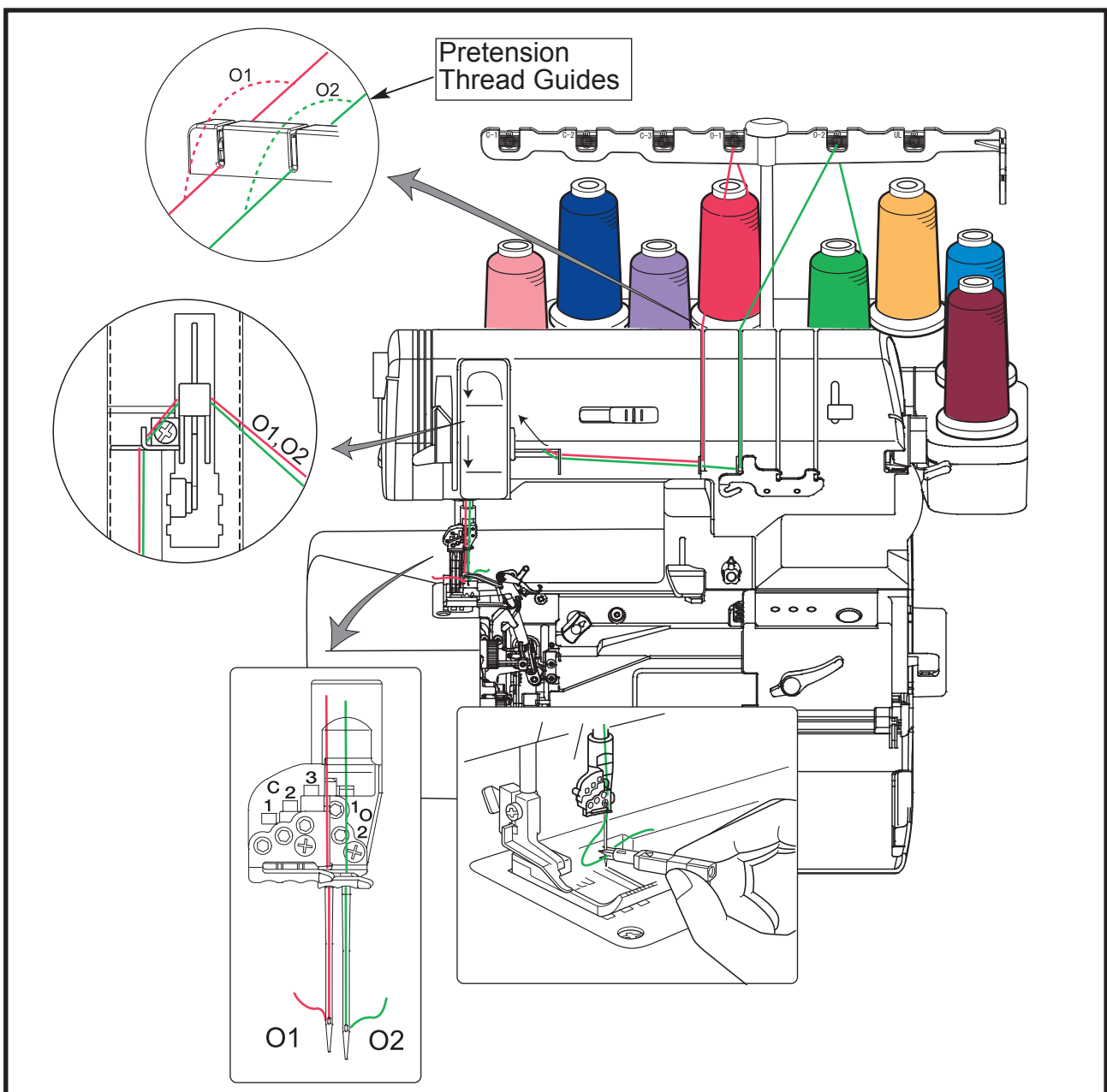

## How To Use The Needle Threader

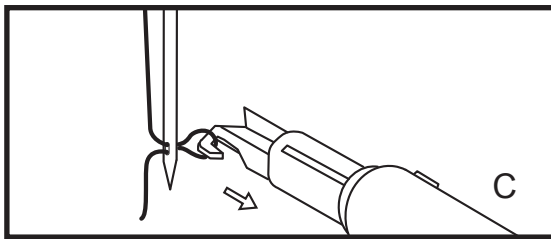
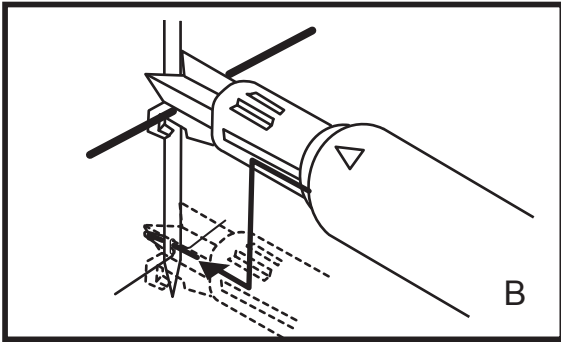
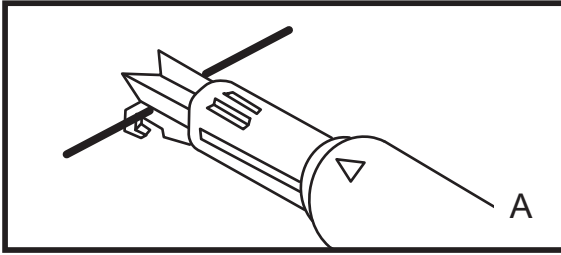

1. Hold the needle threader with the arrow mark on top. Place the thread in the groove of the needle threader. (fig. A)
2. Push the needle threader against the needle shaft above the eye of the needle and then slide down the groove of the needle to the eye. Gently push on the needle threader until the thread is inserted through the eye of the needle and then slowly remove while leaving the thread loop through eye. (fig. B)
3. Using the hook located at the grooved end of the needle threader or the tweezers pull the loop of thread from the back of the needle, place under the foot and to the back left. (fig. C)

## Cutting Blade Cover Seam Guide

Use the marks on your serger's cutting blade cover to align the fabric the desired seam width. Set the width dial at the "M" setting for accurate seam allowances.

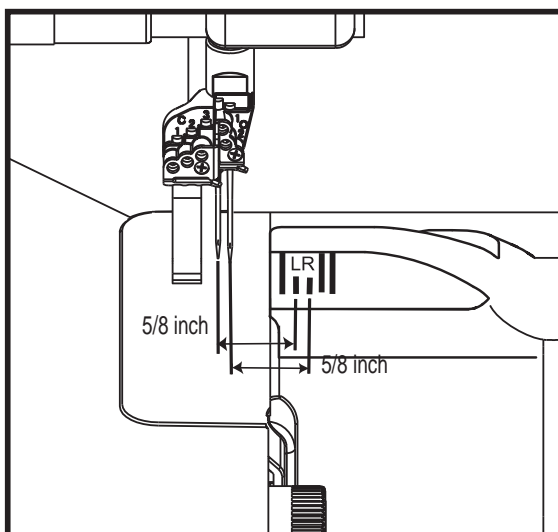

1. The chain stitch (C-3) combined with the 3-thread overlock is the most common 5-thread combination.  
The mark closest to the needles indicates 5/8 inch (16mm) from the cutting edge to the C-3 chain needle.
2. When using the left overlock needles (O-1) for either a 3 or 4-thread overlock seam, the second mark from the needles indicates 5/8 inch (16mm) from the cutting edge to the O-1 overlock needle.
3. Use the right overlock needle (O-2) for 3-thread overlock seam and the third mark from the needles indicates 5/8 inch (16mm) from the cutting edge to the O-2 overlock needle.
4. Other marks on the front cover are for any custom seam allowance.

**Note:** Be sure to set the width dial at the "M" setting for accurate seam allowances.

## Start To Sew

When properly threaded, the loose threads should initially interlock on fabric when sewn. This is most important when sewing the chain or cover stitches.

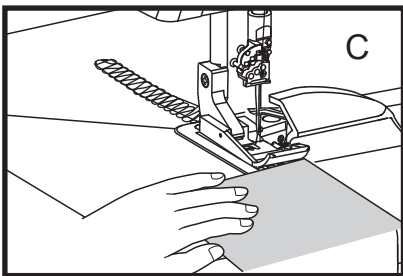
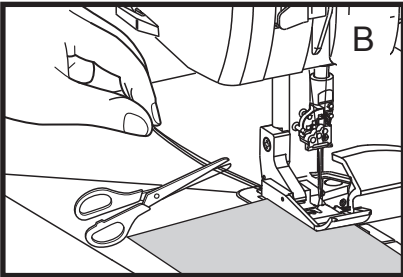
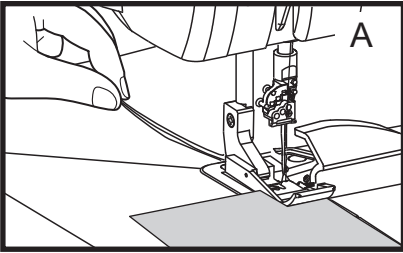

1. Cut all threads to 4 inch (10cm) in length.
2. Place fabric under the presser foot directly below the needles. (fig. A)
3. Lower the presser foot.
4. Turn the handwheel toward you to form 2 or 3 stitches.
5. Start to sew slowly.
6. After the first few stitches, stop and cut excess threads and continue sewing seam. (fig. B)
7. Start the next seam at the toe of the presser foot. (fig. C)
8. You only need to raise and lower the presser foot when working with thick fabrics or when precise positioning is required.

**Note:** Be careful not to push or pull the fabric. The Ovation will feed it evenly without help.

## To Chain-Off of the Fabric

Your Ovation will sew a chain off the edge of the fabric. For best results, we recommend to follow the instructions below.

### Overlock stitches-

1. At the end of the seam, gently pull the fabric and thread to the back to chain-off. (fig. A)
2. When the desired length is reached, cut the thread chain with the thread cutter located on the left side cover. (fig. B)
3. Start the seam by placing the fabric under the front of the foot. (fig. C)

### Chain/Cover stitches-

1. At the end of the seam, change the stitch length to 4 and chain needle tension set at a range from 2 to 0.
2. Let the thread flow from the back of the foot 2-4 inches without pulling.
3. Start the seam by placing the fabric under the front of the foot.

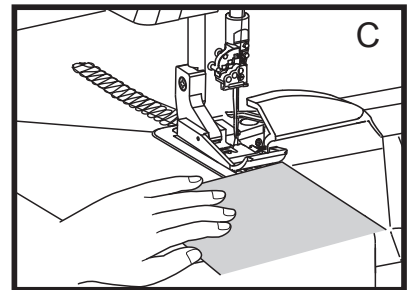
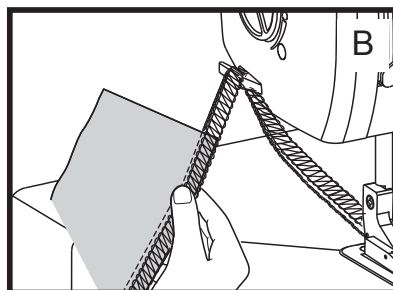
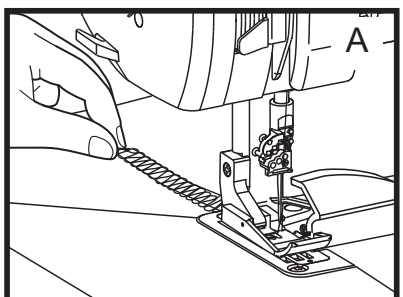

## Clearing the Stitch Width Fingers

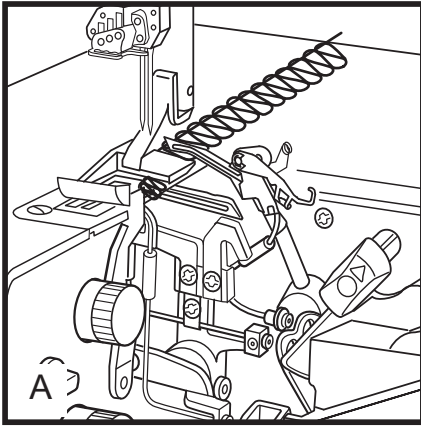

As you sew, you will discover that maneuvering the fabric is different from conventional sewing because the threads form around the stitch fingers. (fig. A)

To clear the stitch fingers, simply raise the presser foot, which releases all threads. Raise the needle(s). Then pull the threads gently from behind the foot. (fig. B) The stitches are now released from the fingers. (fig. C)

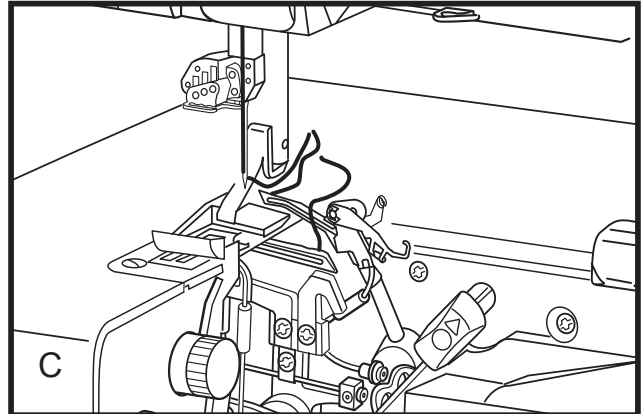
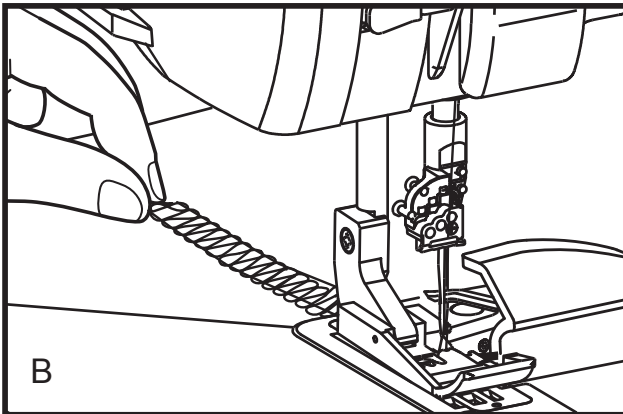

## Re-threading Loopers

If a thread breaks, raise the presser foot and pull the broken thread out from under the foot. Open the front cover and engage the threading lever. (see page 19) Re-thread the machine above the threading port, leaving a 22 inch (56cm) thread tail. Thread the looper as usual then engage the threading lever to the serging position. (see pages 20/21) Close the front cover and sew a test sample.

**Note:** When re-threading your Baby Lock Ovation using the "Extraordin Air Threading" feature, make sure that the previous thread that was in the looper (tube) is completely removed. This will eliminate any chance of the previous thread obstructing the flow of the air when re-threading the machine.

## 4-Thread Overedging

Overedging to finish facings, hems and seams before construction, is one of the most basic uses of a serger, such as making a garment or project with 5/8 inch (16mm) pressed open seams. (fig. A)

To overedge, place the single layer of fabric in front of the presser foot, aligning the cut edge with upper cutting blade. Begin sewing, continuing to guide the fabric along the blade. The edge of the fabric should be trimmed, but not cut away. Then sew the seams on your conventional sewing machine and press them open as usual. (fig. B)

Because notches would be cut away in this process, mark them before sewing with "V" snips just inside the seam allowance or with a water-soluble fabric marker. (fig. C)

**Note:** A 2-thread overlock or 3-thread overlock can also be used with this technique.

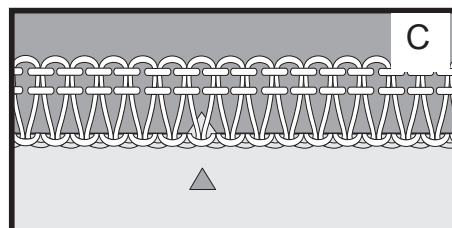
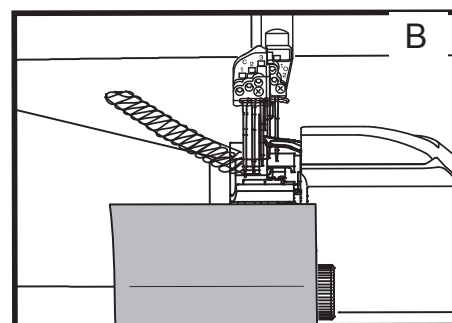
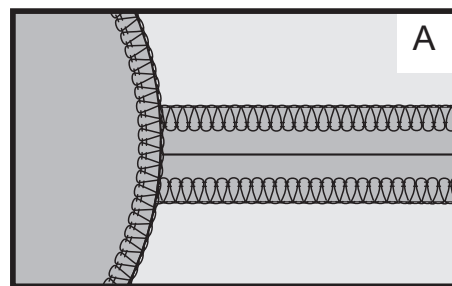

## Overlock Seam

For garments or projects that do not require conventional pressed-open seams, you can stitch and finish the seam in one operation and then press the seams to one side. (fig. A) A 4 or 3-thread seam is strong, yet it provides "give" or flexibility according to the needs of the fabric.

Place two layers of fabric right sides together. Use the marks on your serger's front cover to align the fabric for the desired seam width. Keep your eye on the fabric edge to guide it to the appropriate mark. (fig. B)

Do not watch the needle. If you guide the fabric accurately, the needle will seam in the correct place automatically.

**Note:** For most seaming, pins are unnecessary because the serger feeds the fabric evenly. If you need pins, place the pins parallel to the seam line outside the seam allowance to avoid damaging the blades.

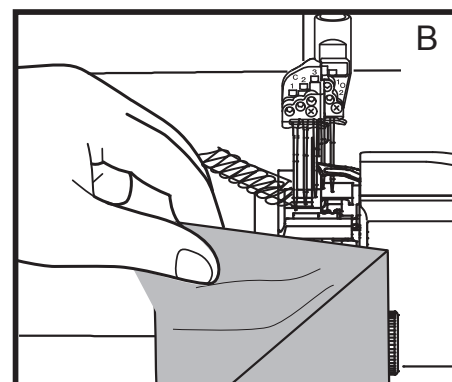
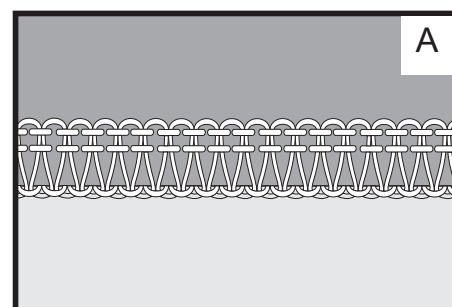

## 4-Thread Overlock

With the Ovation overlock Thread Delivery System, the upper and lower looper threads lock together evenly over the cut fabric edge(s) to form a flat, non-rolling pattern of overlocking stitches on both sides of the fabric.

The left (O1) needle thread interlocks with both looper threads at the stitching line to create the seam. The right (O2) needle thread, visible on the top side of the stitch, interlocks with both the loopers to add durability. The thread, that resembles a zigzag on the upper side of the fabric, is from the upper looper. The thread, that resembles a zigzag on the lower side of the fabric, is from the lower looper.

Move the stitch selector lever to "A".

For a perfect 4-thread overlock stitch, follow the suggested settings and threading diagram below.

| NEEDLES  | LENGTH  | WIDTH   | STITCH SELECTOR | WAVE/OVERLOCK SELECTOR |
|----------|---------|---------|-----------------|------------------------|
| O-1, O-2 | 2.5-4.0 | 6.5-7.5 | A               | OVERLOCK               |

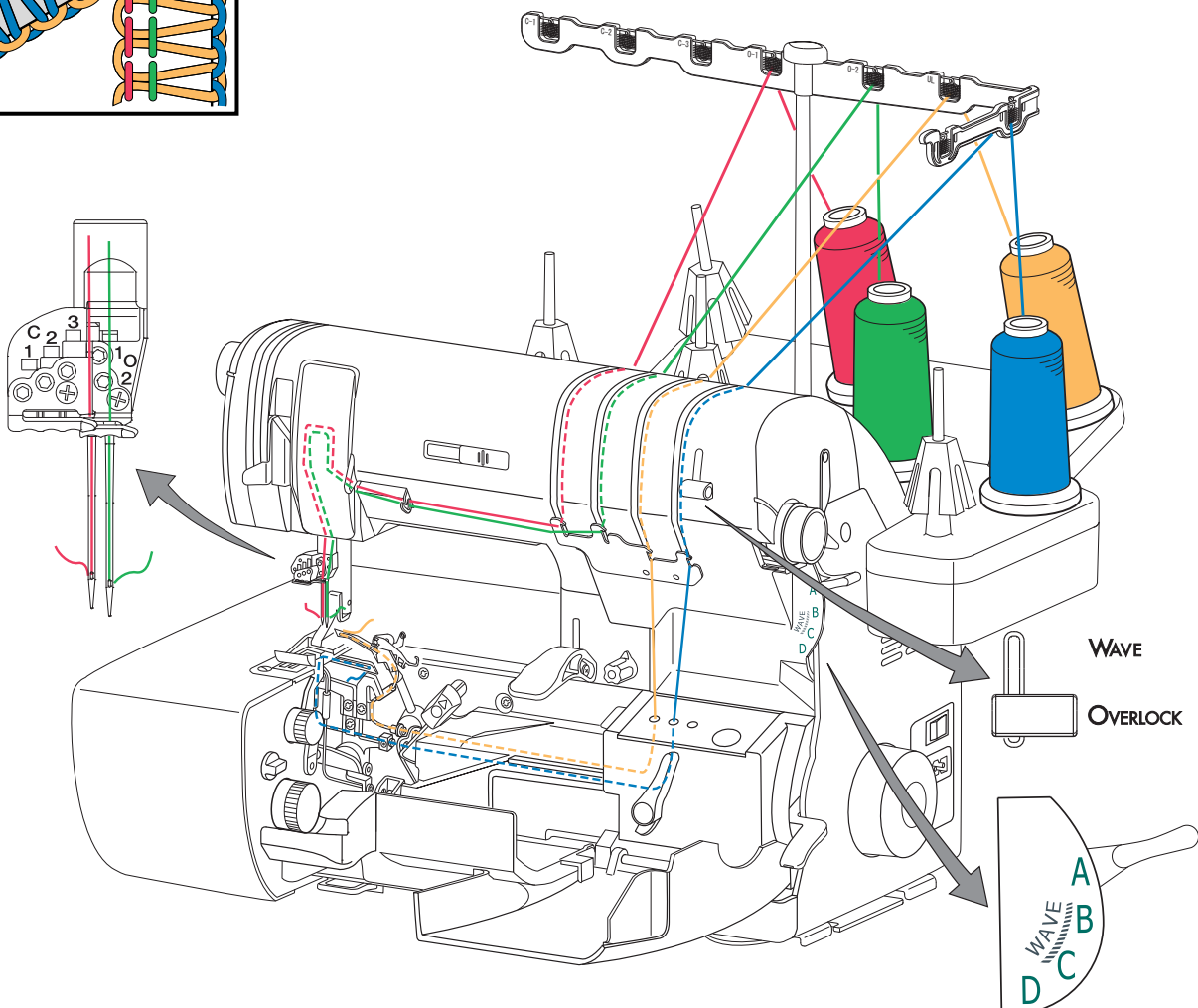
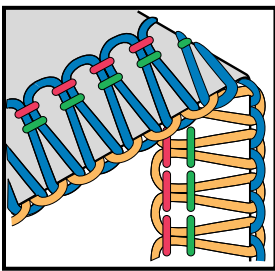

WAVE

OVERLOCK

A  
B  
C  
D

# 3-Thread Overlock - Wide

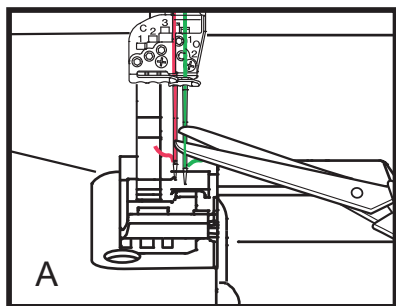

The 3-thread overlock wide stitch is perfect for edge-finishing most woven fabrics and for seaming knits that do not require the extra durability that a fourth thread provides.

To convert your serger to a 3-thread overlock wide (5.5-7.5mm), cut the O-2 needle thread just above the needle eye. (fig. A)  
Remove the O-2 needle and O-2 needle thread completely from the machine. (fig. B)

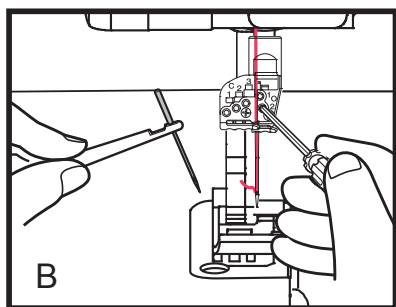

**Note:** Do not tighten needle clamp screw(s) without needle being inserted within the slot.

Move the stitch selector lever to "A".

For O-1 needle, 3-thread overlock, follow the suggested settings and the threading diagram below.

| NEEDLES | LENGTH | WIDTH | STITCH SELECTOR | WAVE/OVERLOCK SELECTOR |
|---------|--------|-------|-----------------|------------------------|
| O-1     | 2-4    | 7.5   | A               | OVERLOCK               |

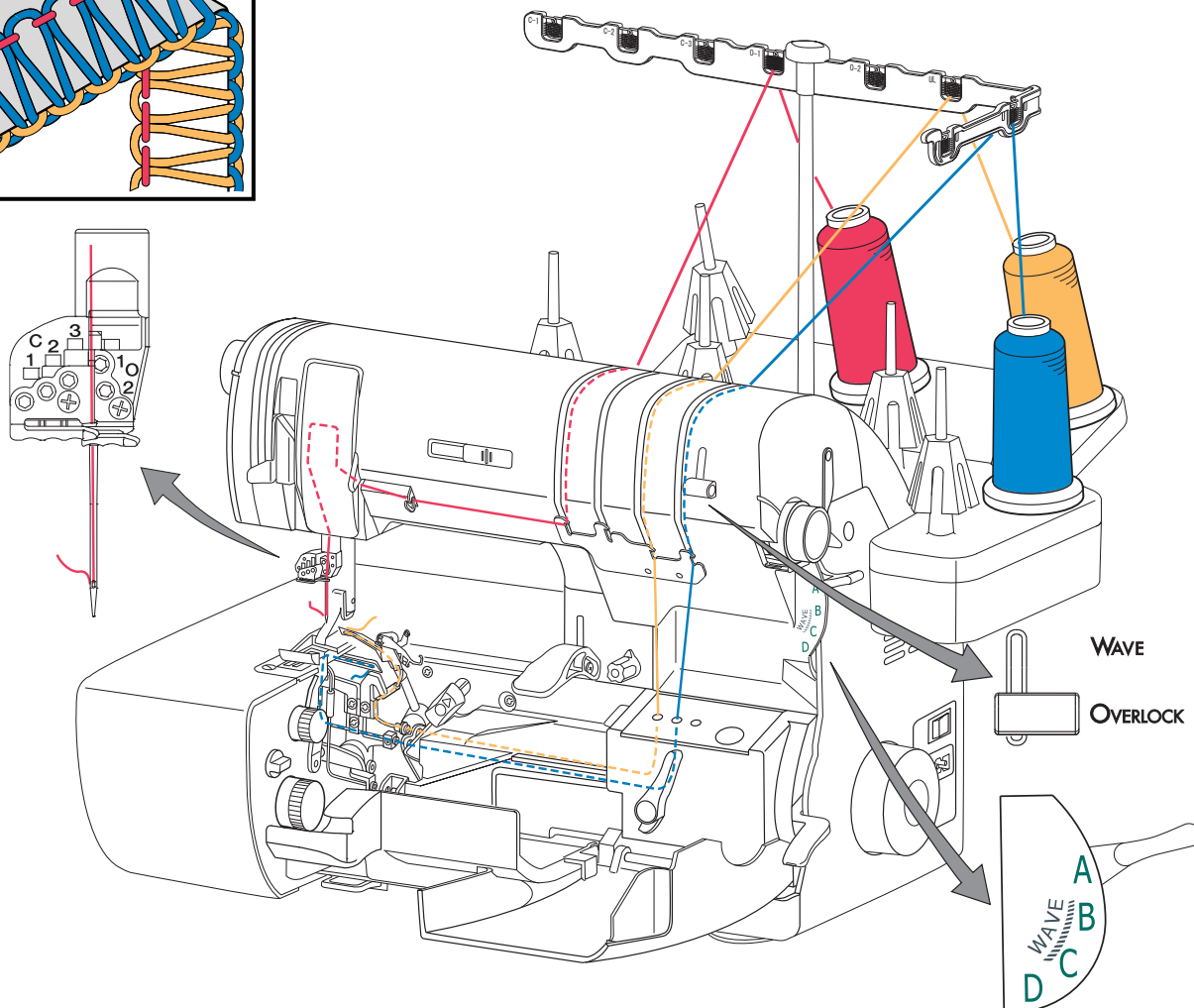
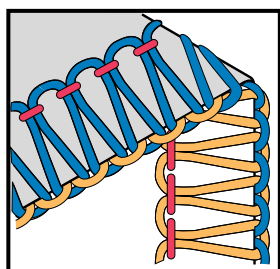

# 3-Thread Overlock - Narrow

To convert to narrow 3-thread overlock (3.0-5.0mm), cut the O-1 needle thread just above the needle eye. (fig. A)

Remove the O-1 needle and O-1 needle thread completely from the machine. (fig. B)

**Note:** Do not tighten needle clamp screw(s) without needle being inserted within the slot.

Move the stitch selector lever to "B".

For the O-2 needle, 3-thread overlock sewing, follow the suggested settings and the threading diagram below.

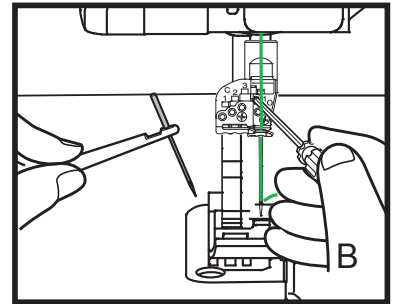
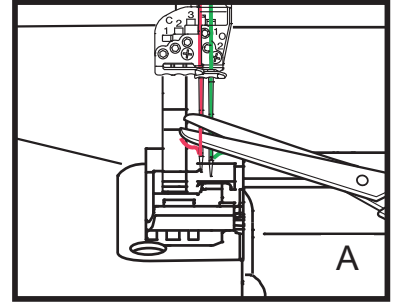

|                |               |              |                         |                                       |
|----------------|---------------|--------------|-------------------------|---------------------------------------|
| NEEDLES<br>O-2 | LENGTH<br>2-4 | WIDTH<br>3.0 | STITCH<br>SELECTOR<br>B | WAVE/OVERLOCK<br>SELECTOR<br>OVERLOCK |
|----------------|---------------|--------------|-------------------------|---------------------------------------|

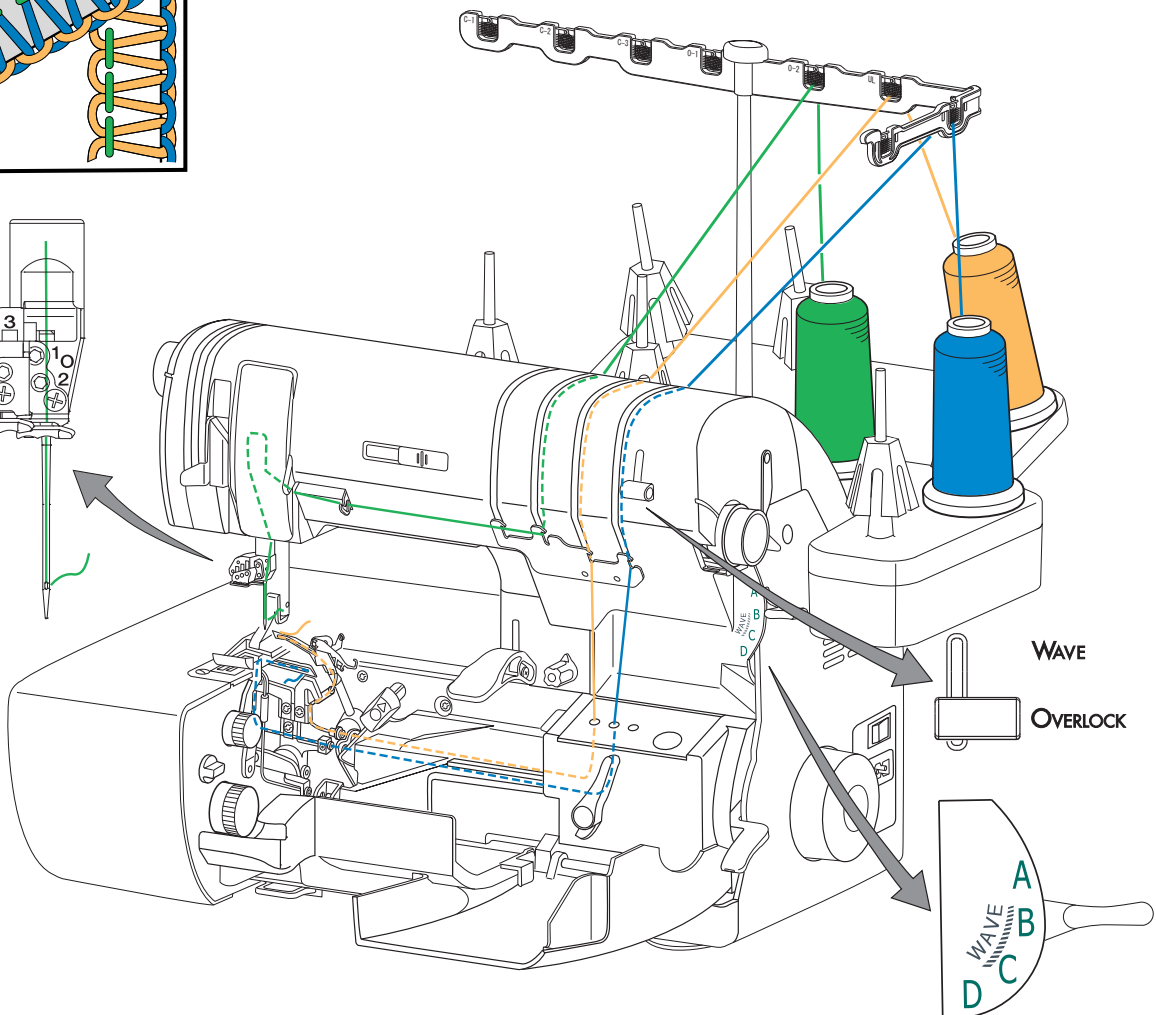
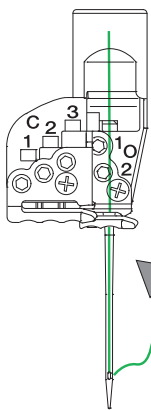
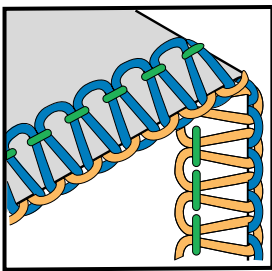

# 3-Thread Overlock - Narrow Hem

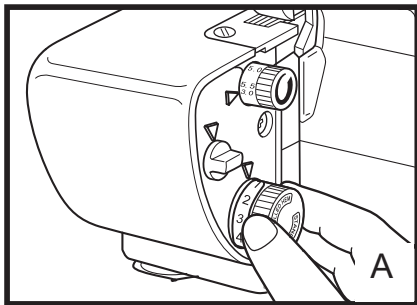

Narrow Hem is an attractive finish for light to medium weight fabrics.

Remove the O-1 needle and needle thread completely from the machine. Clear the stitch fingers. Turn the stitch length adjusting dial clockwise to the rolled hem range. Set the length at "1" (fig. A) and the stitch width at 3.0 (fig. B) for a smooth decorative finish.

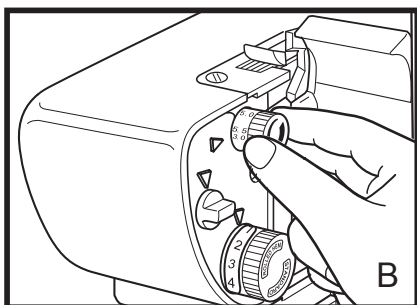

Move the stitch selector lever to "C".

For the O-2 needle 3-thread narrow hem, follow the suggested settings and the threading diagram below.

|                |                     |              |                         |                                       |
|----------------|---------------------|--------------|-------------------------|---------------------------------------|
| NEEDLES<br>O-2 | LENGTH<br>0.75-4.0R | WIDTH<br>3.0 | STITCH<br>SELECTOR<br>C | WAVE/OVERLOCK<br>SELECTOR<br>OVERLOCK |
|----------------|---------------------|--------------|-------------------------|---------------------------------------|

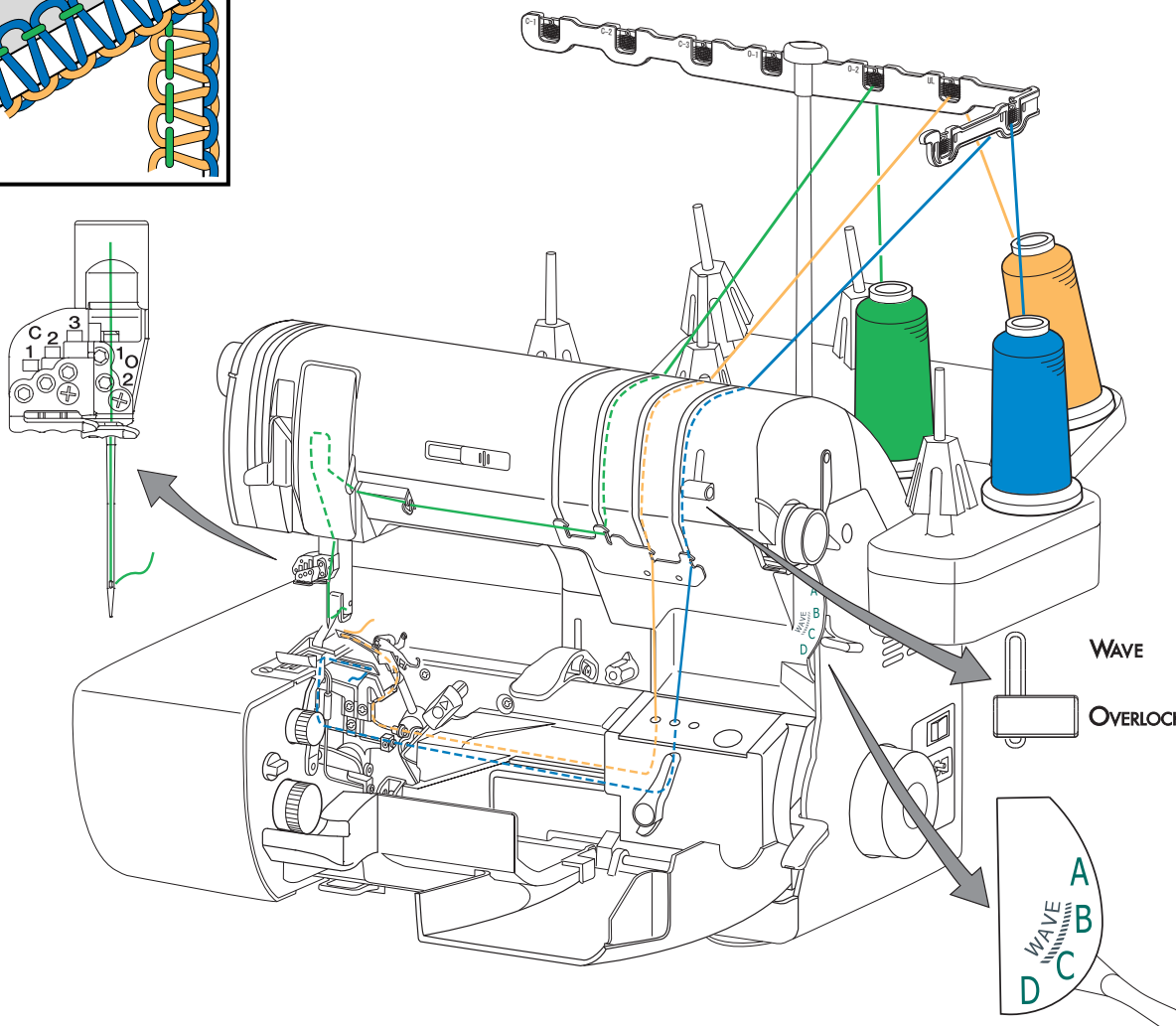
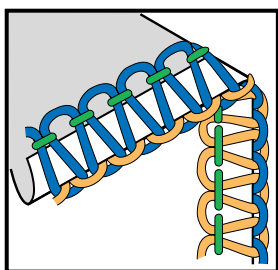

# Rolled Edging

The rolled edge setting is used to achieve the narrowest stitch possible (1.5mm) on your Baby Lock serger. The stitch is suitable for seaming sheer and lightweight fabrics and for edging and hemming lightweight fabrics.

## 3-Thread Rolled Edge

With the stitch selector set on "D", a narrow hem can become a rolled edge. The fabric edge rolls around the stitch finger. The upper looper wraps the fabric edge while the lower looper thread is nearly invisible on the back side of the stitch formation.

Remove the 0-1 needle and thread. Clear the stitch fingers. Turn the stitch length adjusting dial clockwise into the rolled hem range and set the dial at 1.5. (fig. A) Set the stitch width dial to 3.5 "M". (fig. B)

For a 3-thread rolled edge, move the stitch selector lever to "D".

**Note:** These settings may vary depending on thread type and fabric.

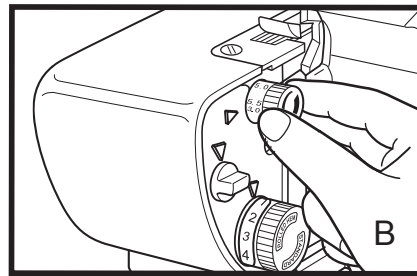
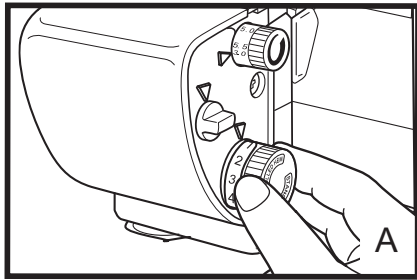

|                |                     |              |                         |                                       |
|----------------|---------------------|--------------|-------------------------|---------------------------------------|
| NEEDLES<br>O-2 | LENGTH<br>0.75-4.0R | WIDTH<br>3.5 | STITCH<br>SELECTOR<br>D | WAVE/OVERLOCK<br>SELECTOR<br>OVERLOCK |
|----------------|---------------------|--------------|-------------------------|---------------------------------------|

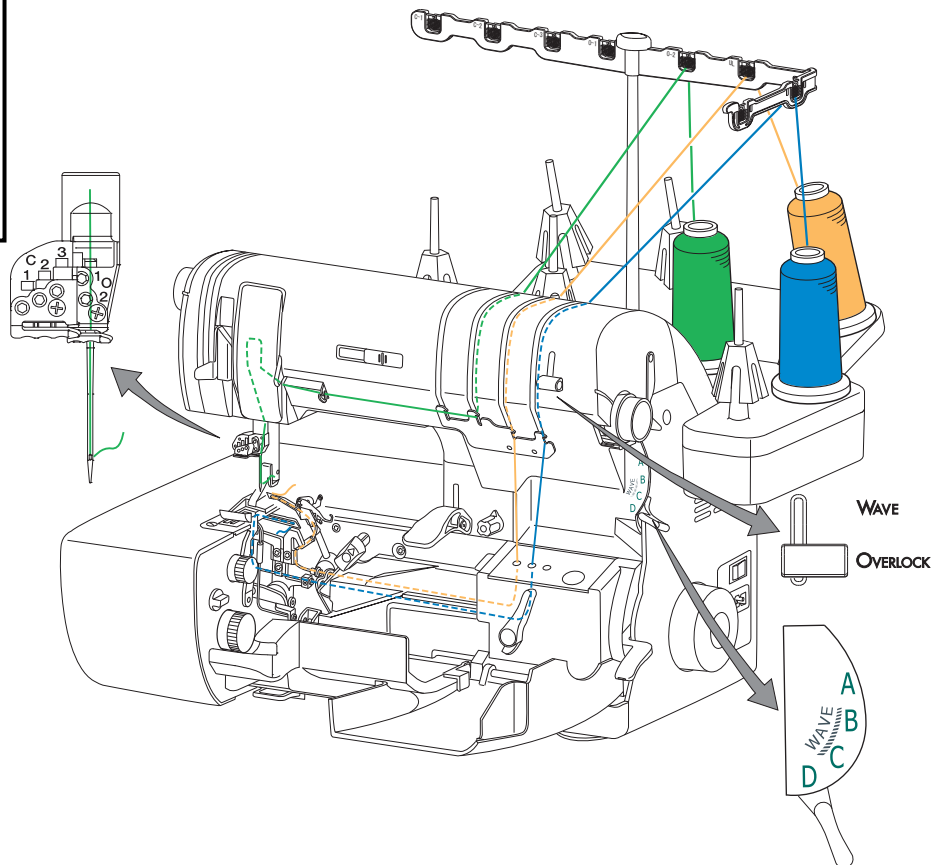
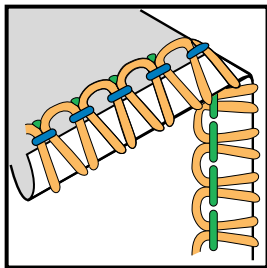

# Seaming Sheers

Use the 3-thread rolled hem setting when sewing sheer fabrics. Set the stitch length at 2.5. Sew the seams, aligning the fabric edge with the serger's seam guides, trimming away the excess seam allowance.

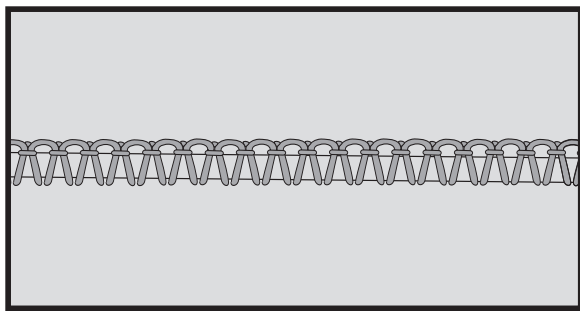
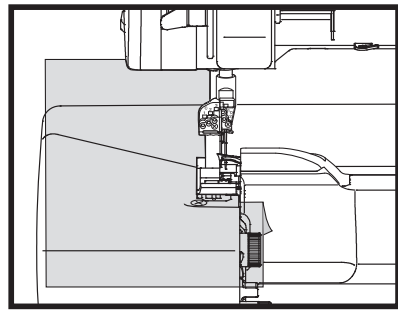

# Lettuce Edge

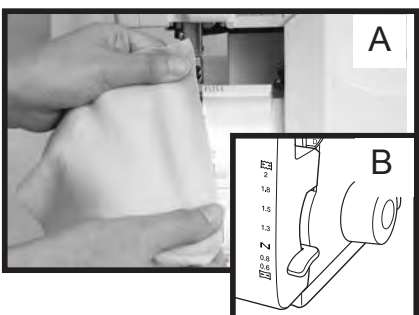

A frilly or "lettuce" edge can be created on most light and medium weight stretch and on bias edges of soft, woven fabrics. It makes a pretty decorative edging for activewear, lingerie, accessories and children's wear.

Set the machine for the 3-thread rolled edge. Set differential feed at 0.6. (fig. B) Sew the fabric in the direction of greatest stretch-the crossgrain on knits, bias grain on wovens. (fig. A) For a "leafier" effect, try using a shorter stitch length and gently stretch the fabric as it is being sewn. Sew a test sample. (fig. C)

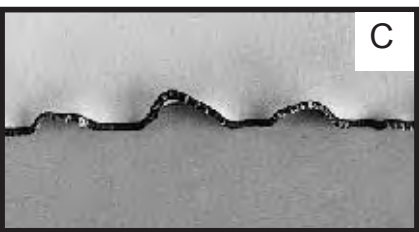

**Note:**To avoid the stitching from pulling away from the fabric, increase the width to a slightly larger number.

# Belt Loops and Button Loops

Using the Rolled Edging stitch create a thread chain, stitching without fabric, to make professional belt loops and button loops. Using heavier decorative thread gives a stronger loop.

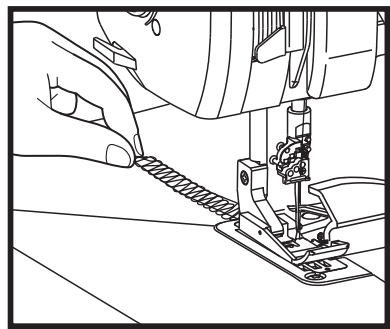

# Returning to Standard Serging

Clear the stitch fingers and return the stitch length dial to the standard range. Set stitch width and length at the desired settings. Replace the left needle and its corresponding thread, if desired.

# 3-Thread Flatlock - Narrow

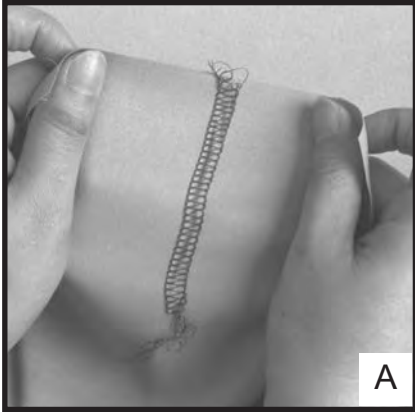

Flatlock seams are most suited to fabrics which do not ravel such as interlock knits, tricot, sweatshirt fleece and synthetic suede. The needle thread is carried below the fabric and to the cut edge of the fabric. The lower looper thread rides along the cut edge of the fabric for stability. The edges pull open and flatten within the stitch for a non-bulky join. (fig. A) Be sure to sew a test sample first to determine whether the stitch will have the strength to hold the seam without the fabric pulling away.

Move the stitch selector lever to "D".

For the O-2 needle 3-thread narrow flatlock, follow the suggested settings and the threading diagram below.

|                |               |                  |                         |                                       |
|----------------|---------------|------------------|-------------------------|---------------------------------------|
| NEEDLES<br>O-2 | LENGTH<br>2-4 | WIDTH<br>3.0-3.5 | STITCH<br>SELECTOR<br>D | WAVE/OVERLOCK<br>SELECTOR<br>OVERLOCK |
|----------------|---------------|------------------|-------------------------|---------------------------------------|

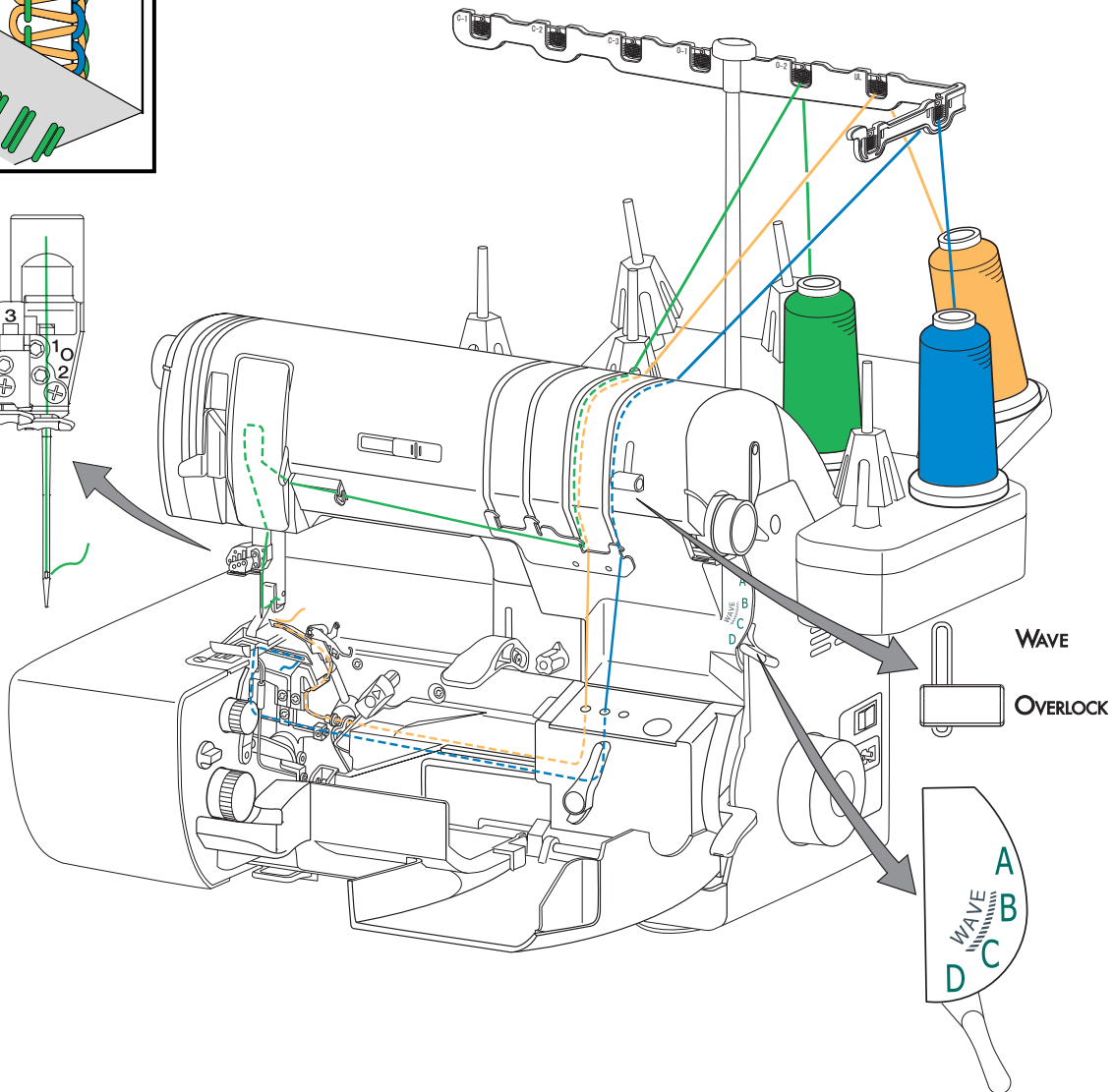
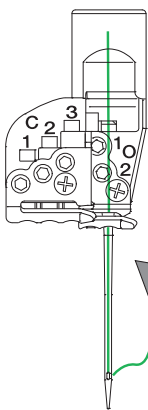
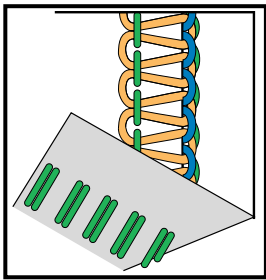

## 2-Thread Overlock

The 2-thread function provides an economical and less bulky means of overedging all fabrics. The standard 2-thread overlock is the same as a 2-thread flatlock stitch.

When sewn with specialty threads, 2-thread sewing makes decorative seams and edges for activewear, children's clothing, ruffles, and hemlines.

## Converting from 3-Thread to 2-Thread Overlock

Either overlock needle may be engaged for 2-thread overlock sewing.

1. Open the front cover and the blade cover. Cut the upper looper thread just above the threading port. (fig. A)
2. Raise the presser foot and remove the upper looper and needle threads from the machine.
3. Rotate the handwheel to bring the upper looper into position to attach the subsidiary looper. Rotate the subsidiary looper up and to the left (fig.B) then slip the end into the eye of the upper looper. (fig.C)
4. Place the left needle thread on the "OVERLOCK NEEDLE 1" spool pin (or right needle thread on the "OVERLOCK NEEDLE 2" spool pin) and bring the thread through the telescopic antennae thread guide directly above the spool of thread. Snap the thread into the pretension thread guide on top of machine that is normally used for the upper looper (3rd from left), and down the front of the machine. Then take the thread to the left and thread the machine as you would for the needles in their normal position. (see illustrations on pages 36 and 37 for correct threading and suggested settings)
5. Using the needle threader in the accessory compartment, thread the eye of left needle O-1, (or right needle O-2). Place the looper and needle threads under the presser foot and to the back.
6. Close the cutting blade cover and front cover.
7. The needle and lower looper threads should overcast evenly on the cut edge of the fabric.

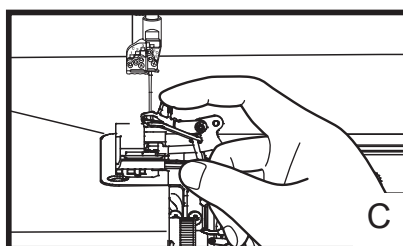
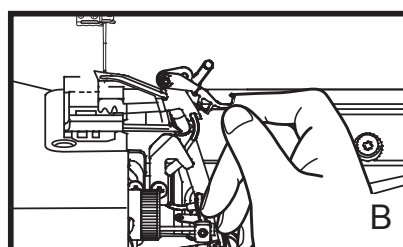
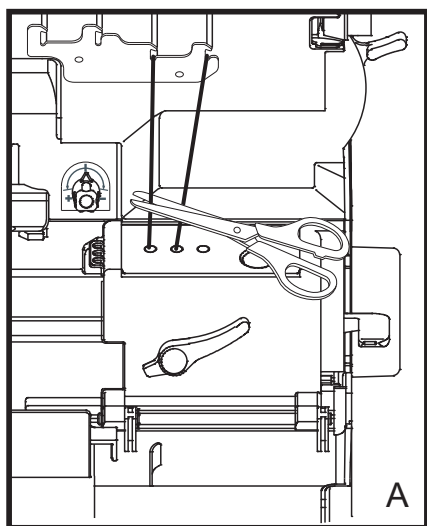

# 2-Thread Flatlock - Wide



When sewn on a fold, flatlocking can create a decorative effect within the body of a garment or project. Either follow placement lines on your pattern or design your own special effects by stitching the fabric before laying out pattern pieces. Then open the fabric fold and gently pull both sides until the flatlock stitching lies flat. (fig. A)

Be sure to sew a test sample first.

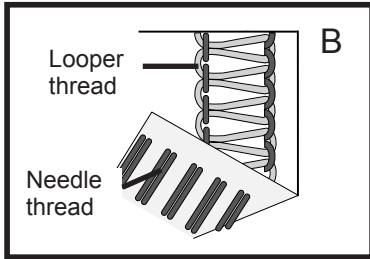

## For 2-thread flatlock - wide

1. Engage the threading lever in threading position.
2. Place the needle thread on the "OVERLOCK NEEDLE 1" spool pin. Slip the thread through the "O-1" telescopic antennae thread guide directly above the spool.
3. Snap needle thread into the upper looper pretension thread guide on top of the machine, then go down the upper looper thread path in the front of the machine. Go left with the needle thread toward the hooked thread guide on front of the machine. Then take the needle thread through the normal needle thread paths (see illustration below).
4. Turn the cutting blade to the "locked" position.
5. Engage the subsidiary looper (following step 3 on page 35).
6. Thread the lower looper as shown in the illustration below.
7. Engage the threading lever in the serging position.



For "loops" (lower looper thread) to show on the right side, place fabric wrong sides together for sewing the seam. To produce the "ladder" (needle thread) on the outside, place the fabric right sides together. (fig. B)

Position the fabric under the presser foot, aligning the fold of the fabric 1/8 inch (3.5mm) to the left of the upper cutting blade.

**Note:** If the fabric does not pull completely flat under the stitches, guide the fabric fold to the left so that the loops hang slightly off the fold as they are being stitched. (fig.C)

Move the stitch selector lever to "A" and follow the suggested settings and threading diagram below.

|                |               |              |                         |                                       |
|----------------|---------------|--------------|-------------------------|---------------------------------------|
| NEEDLES<br>O-1 | LENGTH<br>2-4 | WIDTH<br>7.5 | STITCH<br>SELECTOR<br>A | WAVE/OVERLOCK<br>SELECTOR<br>OVERLOCK |
|----------------|---------------|--------------|-------------------------|---------------------------------------|

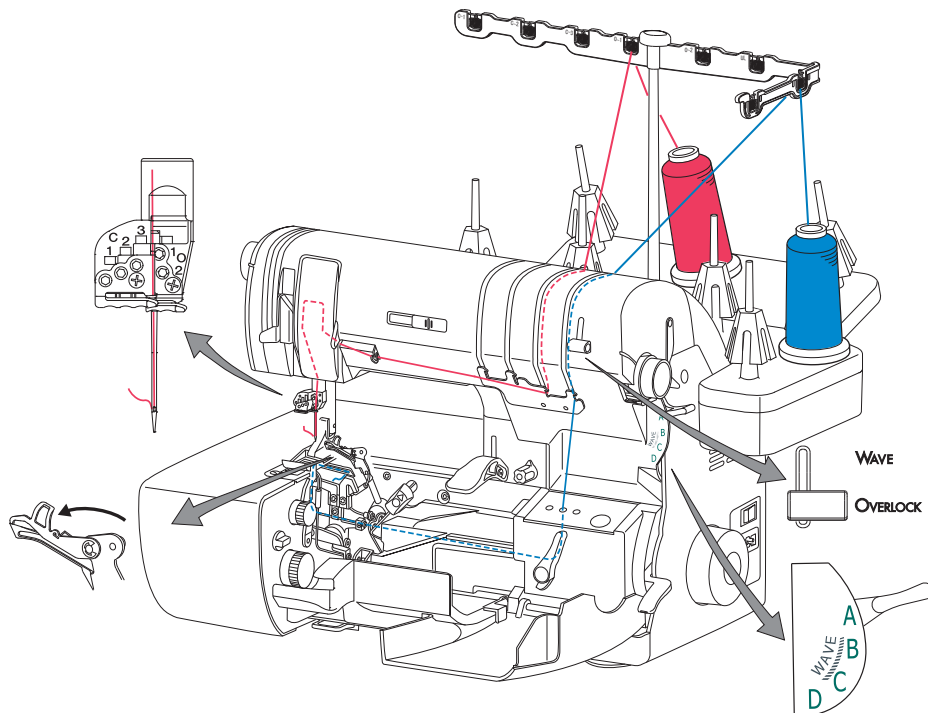
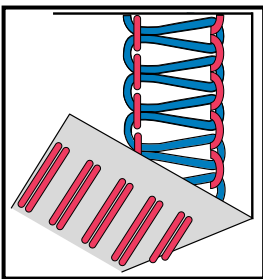

# 2-Thread Flatlock - Narrow

Sew a 2-thread flatlock seam then pull the two fabric layers apart until the seam lies flat. (fig. A)  
 Because the threads show on the outside as well as the inside of the garment or project, the flatlock seam is often considered a decorative application. (fig. B)

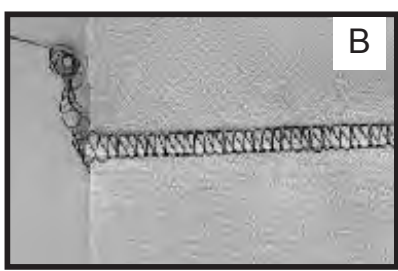

**For 2-thread flatlock - narrow**

1. Engage the threading lever in threading position.
2. Place needle thread on "OVERLOCK NEEDLE 2" spool pin and slip the thread through the "O-2" telescopic antennae thread guide directly above the spool.
3. Snap needle thread into the upper looper pretension thread guide on top of the machine, then go down the upper looper thread path in the front of the machine. Go left with the needle thread toward the hooked thread guide on front of the machine. Then take the needle thread through the normal needle thread paths (see illustration below).
4. Engage the subsidiary looper (following step 3 on page 35).
5. Thread the lower looper as shown in the illustration below.
6. Engage the threading lever in the serging position.

Before serging, decide which stitch pattern you want to have on the outside of the garment. For "loops" (lower looper thread) to show, place fabric wrong sides together for sewing the seam. (fig. C)  
 To produce the "ladder" (needle thread) on the outside, place the fabric right sides together. (fig. D)

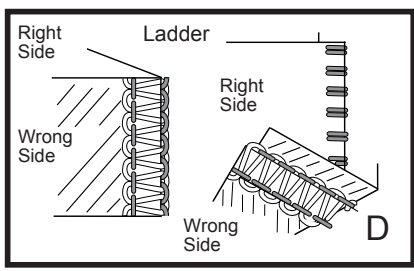
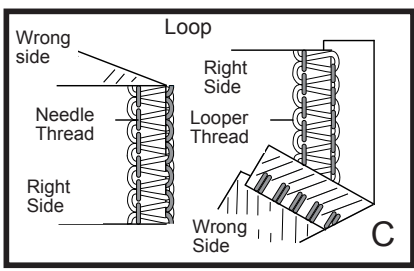

|                |               |              |                         |                                       |
|----------------|---------------|--------------|-------------------------|---------------------------------------|
| NEEDLES<br>O-2 | LENGTH<br>2-4 | WIDTH<br>3.5 | STITCH<br>SELECTOR<br>B | WAVE/OVERLOCK<br>SELECTOR<br>OVERLOCK |
|----------------|---------------|--------------|-------------------------|---------------------------------------|

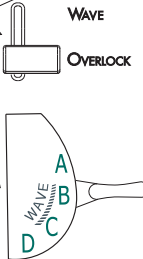
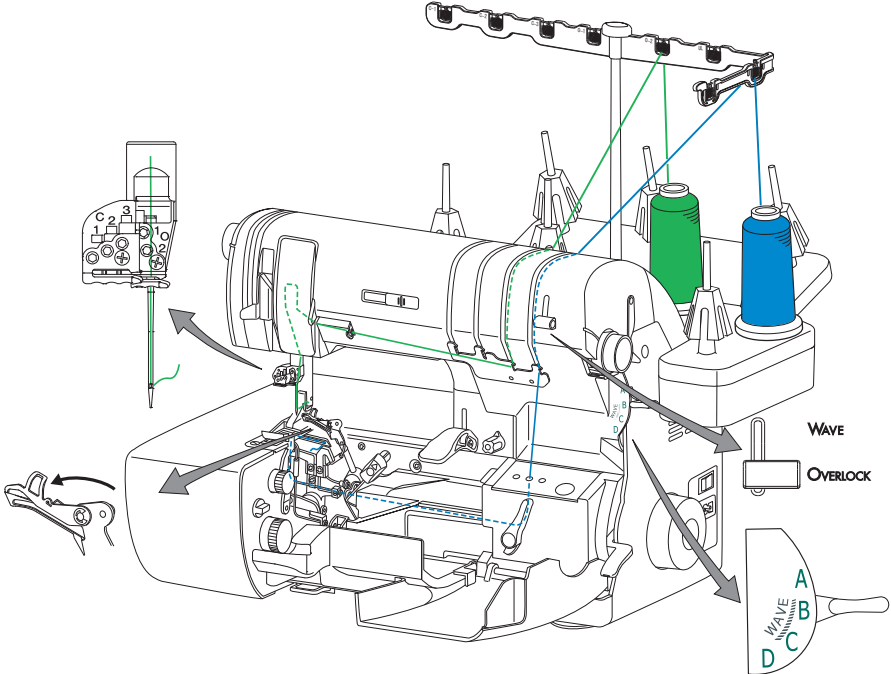
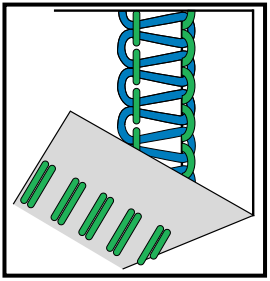

# Blanket Stitch - Decorative Stitch

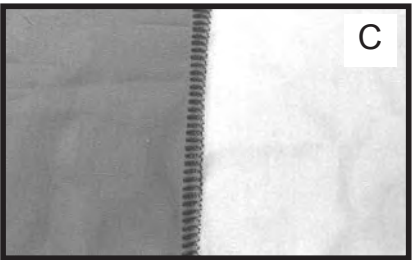

Set up the machine for 2-thread flatlock - wide but the needle threading path is different for this technique.

1. Insert a size 90 top stitch needle in left (O-1) overlock needle position.
2. Engage the threading lever in threading position.
3. Swing the subsidiary looper into place on the upper looper. (Refer to below illustrations for Steps 3 - 6)
4. Thread serger sewing thread in the lower looper.
5. Place a heavy decorative thread that will be used in the needle on the "OVERLOCK NEEDLE 1" spool pin and thread the needle thread through upper looper thread path.
6. Engage the threading lever to the serging position, pull the thread out of the upper looper tube and continue to thread the needle as illustrated.
7. Place water-soluble stabilizer on top of the fabric, along the edge.
8. Stitch along the edge of the fabric. (fig.A)
9. When finished stitching, pull the water-soluble stabilizer to the right of the fabric. (fig.B) This will pull the stitching to the edge and will look like a blanket stitch. (fig.C)

Move the stitch selector lever to "A" and follow the suggested settings and threading diagram below.

| NEEDLES                             | LENGTH | WIDTH | STITCH SELECTOR | WAVE/OVERLOCK SELECTOR |
|-------------------------------------|--------|-------|-----------------|------------------------|
| O-1<br>size 90 Top Stitch<br>Needle | 3-4    | 7.5   | A               | OVERLOCK               |

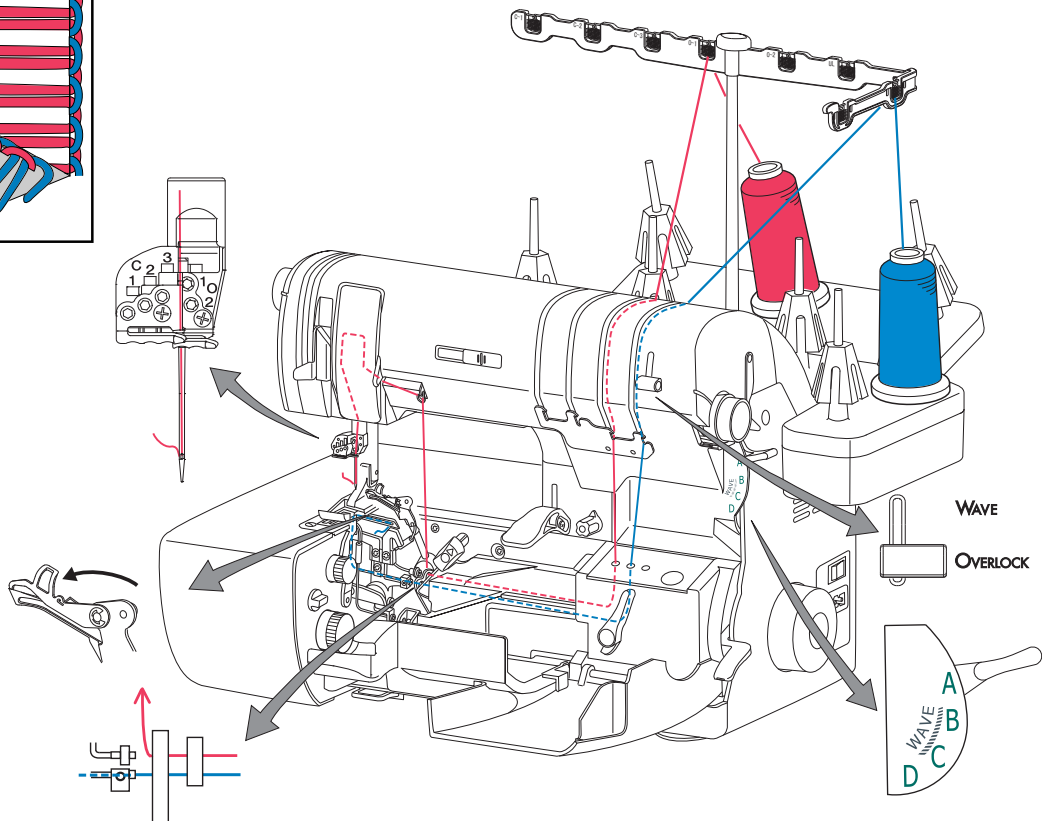
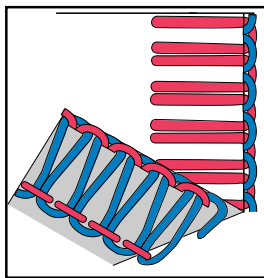

# Ladder Stitch - Decorative Stitch

Set up the machine for 2-thread flatlock - wide but the needle threading path is different for this technique.

1. Insert a size 90 top stitch needle in left (O-1) overlock needle position.
2. Engage the threading lever in threading position.
3. Swing the subsidiary looper into place on the upper looper. (Refer to below illustrations for Steps 3 - 6)
4. Thread serger sewing thread in the lower looper.
5. Place a heavy decorative thread that will be used in the needle on the "OVERLOCK NEEDLE 1" spool pin and thread the needle thread through upper looper thread path.
6. Engage the threading lever to the serging position, pull the thread out of the upper looper tube and continue to thread the needle as illustrated.
7. Place the fabric pieces right sides together for the decorative ladder to be on the right side of the fabric. (This can also be done on the fold as well)
8. Sew the fabric together and gently pull open; revealing the decorative ladder stitching on the right side of the fabric.

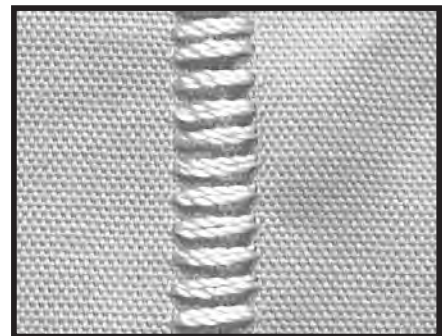
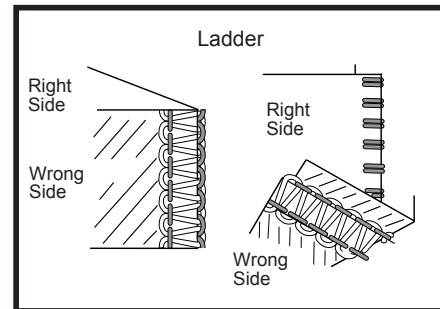

Move the stitch selector lever to "A" and follow the suggested settings and threading diagram below.

| NEEDLES                             | LENGTH | WIDTH | STITCH SELECTOR | WAVE/OVERLOCK SELECTOR |
|-------------------------------------|--------|-------|-----------------|------------------------|
| O-1<br>size 90 Top Stitch<br>Needle | 3-4    | 7.5   | A               | OVERLOCK               |

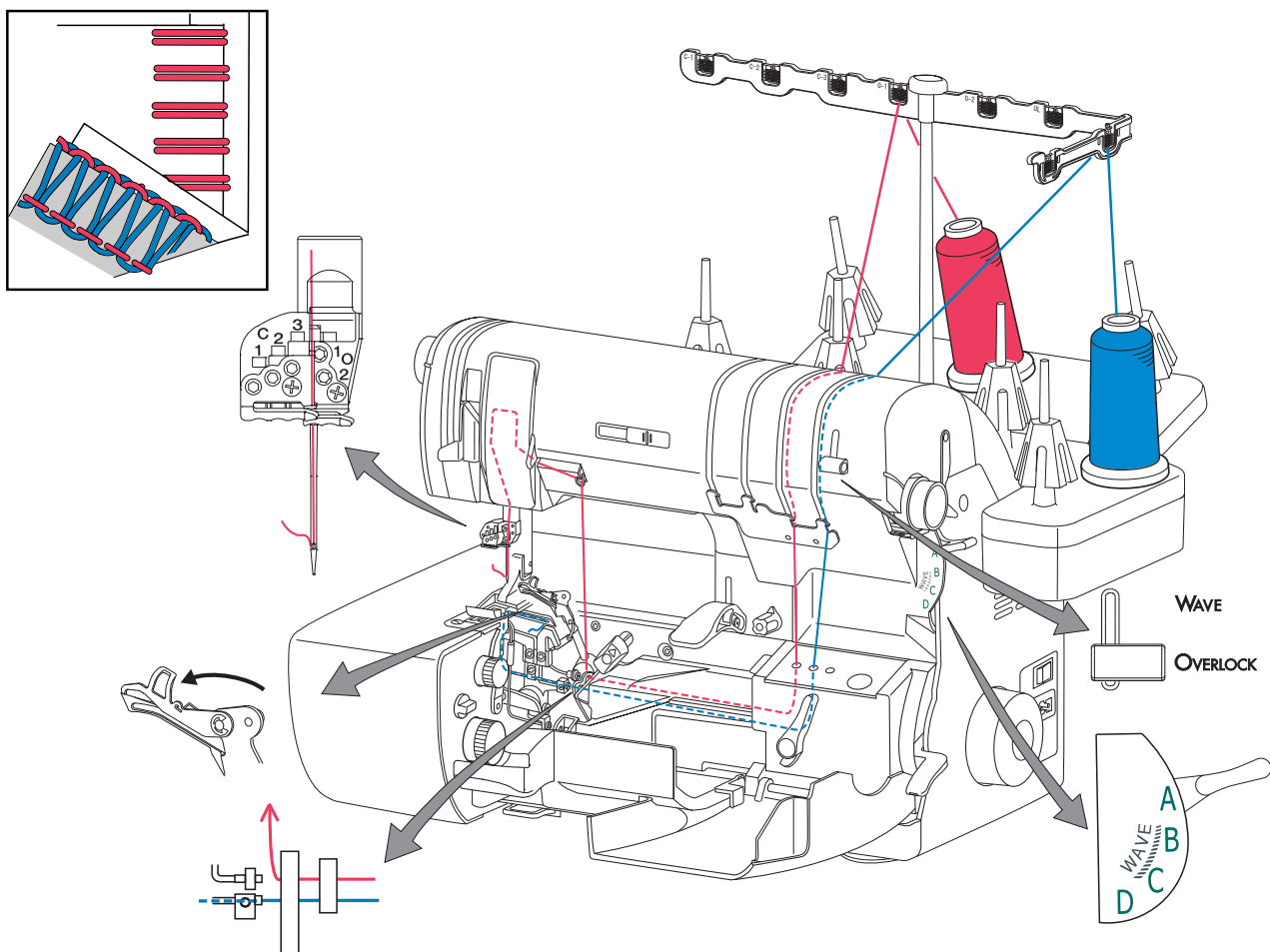

## Wave Stitch

The Wave Stitch provides a decorative "wavy" edging on fabric. (This is not to be confused with "Lettuce Edge" on page 33) The upper looper thread and the lower looper thread gradually appear every 25 stitches to create a stitch that looks like a "Wave". When using different color specialty threads (pages 76 & 77) for the upper or lower loopers, the Wave stitch creates an attractive stitch for edging.

When combining decorative threads for the Wave stitch, please sew test on a sample of the fabric you will be sewing on before applying the Wave stitch.

For best results, heavier decorative threads should be limited to the upper or lower looper at one time. Not both upper looper and lower looper at the same time. Woolly nylon in the corresponding looper and serger sewing thread in the right needle will make a striking combination with the heavy decorative thread.

## Converting from Normal Serging to Wave

1. Move the Wave/Overlock Selector lever from "OVERLOCK" to "WAVE".
2. Cut the threads from the thread cones, raise presser foot and remove threads from the thread paths.
3. Engage the threading lever in threading position, for threading the loopers. (see page 19)
4. Place the thread cone on the OVERLOCK NEEDLE 2 spool pin.
5. Glide the thread through the telescopic antennae thread guide "O-2" directly above the thread spool. Follow the "OVERLOCK NEEDLES 1" threading path down to the "O-2" overlock needle.
6. Thread the O-2 needle using the needle threader. (see page 24)
7. Place the thread cone on the UPPER LOOPER spool pin.
8. Glide the upper looper thread through the telescopic antennae thread guide "UL" directly above the thread spool. Follow the "OVERLOCK NEEDLES 2" threading path for the UPPER LOOPER thread, down the front threading path, to the right of the chrome thread guide, and directly to the "U" threading port for the upper looper. Thread the upper looper. (see page 20)
9. Place the "O-2" needle thread and upper looper thread under the presser foot and to the back.
10. Place the thread cone on the LOWER LOOPER spool pin.
11. Thread lower looper using standard lower looper threading technique. (Refer to Steps 2 - 6 on page 20)
12. Engage the threading lever to the serging position.
13. Set Stitch Selector Lever for Wave Stitch or Rolled Wave Stitch. (see pages 41 to 43 for suggested settings)
14. Set Stitch Length and Stitch Width (following the suggested settings on page 41, 42 or 43).

**Note:** Recommended settings will vary depending on thread type and fabric.

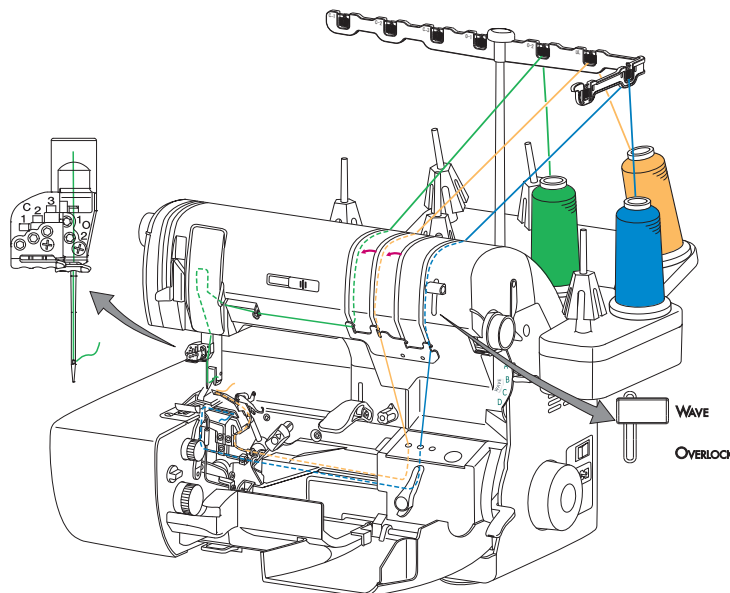

## 3-Thread Wave Stitch

1. Move the Wave/Overlock Selector lever from "OVERLOCK" to "WAVE".
2. Cut the threads from the thread cones, raise presser foot and remove threads from the thread paths.
3. Engage the threading lever in threading position for threading the loopers. (see page 19)
4. Place the thread cone on the OVERLOCK NEEDLE 2 spool pin.
5. Guide the thread through the telescopic antennae thread guide "O-2" directly above the thread. Follow the "OVERLOCK NEEDLES 1" threading path down to the "O-2" overlock needle.
6. Thread the O-2 needle using the needle threader. (see page 24)
7. Place the thread cone on the UPPER LOOPER spool pin.
8. Guide the upper looper thread through the telescopic antennae thread "UL" guide directly above the thread spool. Follow the "OVERLOCK NEEDLES 2" threading path for the UPPER LOOPER thread, down the front threading path, to the right of the chrome thread guide, and directly to the "U" threading port for the upper looper. Thread the upper looper. (see page 20)
9. Place the "O-2" needle thread and upper looper thread under the presser foot and to the back.
10. Place the thread cone on the LOWER LOOPER spool pin.
11. Thread lower looper using standard lower looper threading technique. (Refer to Steps 2 - 6 on page 20)
12. Engage the threading lever to the serging position.
13. Set Stitch Selector Lever on "B" for Wave Stitch.
14. Set Stitch Length and Stitch Width following the suggested settings below.

**Note:** Recommended settings will vary depending on thread type and fabric.

| NEEDLES | LENGTH   | WIDTH | STITCH SELECTOR | WAVE/OVERLOCK SELECTOR |
|---------|----------|-------|-----------------|------------------------|
| O-2     | 0.75-2.5 | 5.0   | B               | WAVE                   |

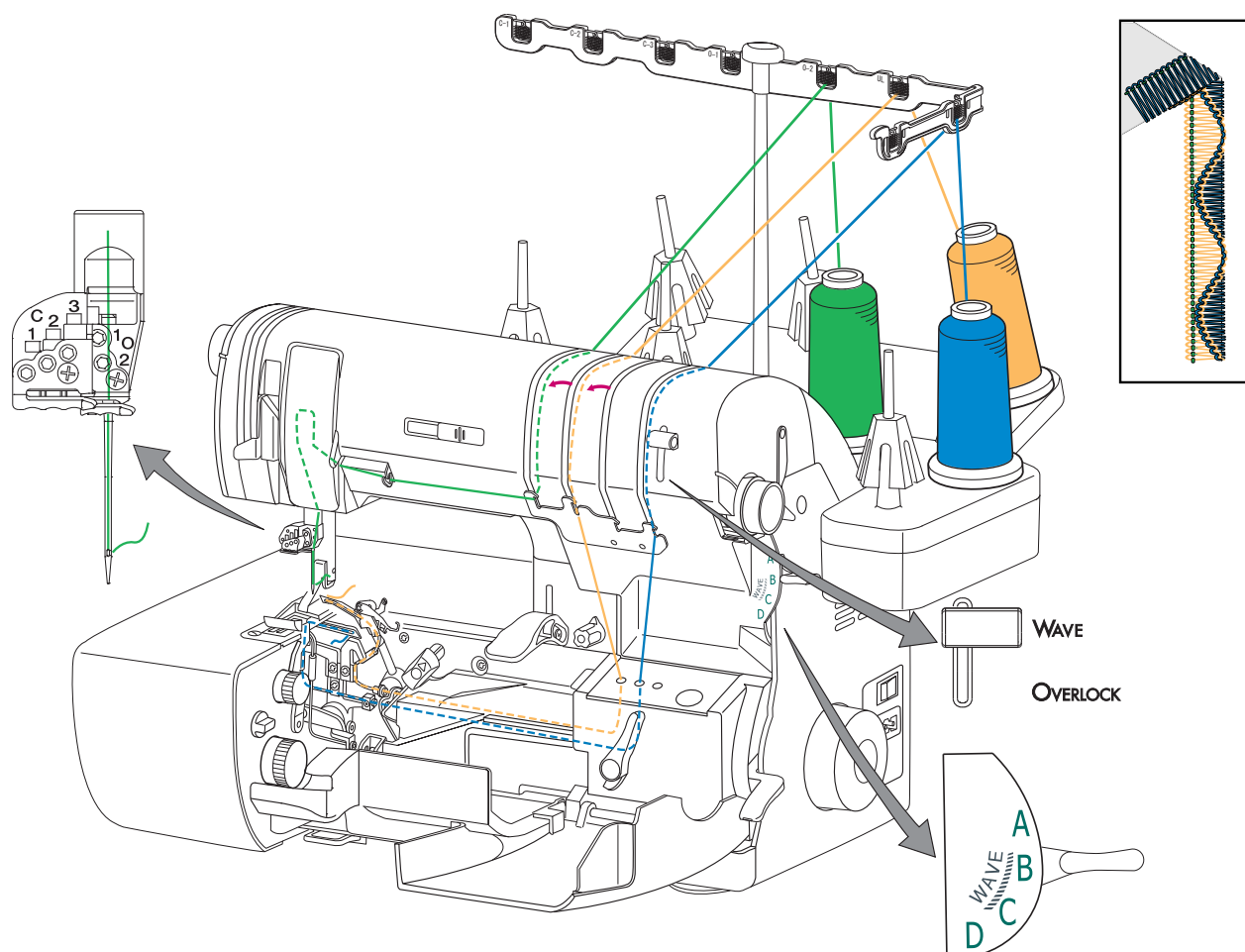

# 3-Thread Rolled Wave Stitch

1. Move the Wave/Overlock Selector lever from "OVERLOCK" to "WAVE".
2. Cut the threads from the thread cones, raise presser foot and remove threads from the thread paths.
3. Engage the threading lever in threading position, for threading the loopers. (see page 19)
4. Place the thread cone on the OVERLOCK NEEDLE 2 spool pin.
5. Guide the thread through the telescopic antennae thread guide "O-2" directly above the thread spool. Follow the "OVERLOCK NEEDLES 1" threading path down to the "O-2" overlock needle.
6. Thread the O-2 needle using the needle threader. (see page 24)
7. Place the thread cone on the UPPER LOOPER spool pin.
8. Guide the thread through the telescopic antennae thread guide "UL" directly above the thread spool. Follow the "OVERLOCK NEEDLES 2" threading path for the UPPER LOOPER thread, down the front threading path, to the right of the chrome thread guide, and directly to the "U" threading port for the upper looper. Thread the upper looper. (see page 20)
9. Place the "O-2" thread and upper looper thread under the presser foot and to the back.
10. Place the thread cone on the LOWER LOOPER spool pin.
11. Thread lower looper using standard lower looper threading technique. (Refer to Steps 2 - 6 on page 20)
12. Engage the threading lever to the serging position.
13. Set Stitch Selector Lever on "C" for Rolled Wave Stitch.
14. Set Stitch Length and Stitch Width following the suggested settings below.

**Note:** Recommended settings will vary depending on thread type and fabric.

| NEEDLES | LENGTH      | WIDTH   | STITCH SELECTOR | WAVE/OVERLOCK SELECTOR |
|---------|-------------|---------|-----------------|------------------------|
| O-2     | 0.75 - 1.5R | 3.0-5.0 | C               | WAVE                   |

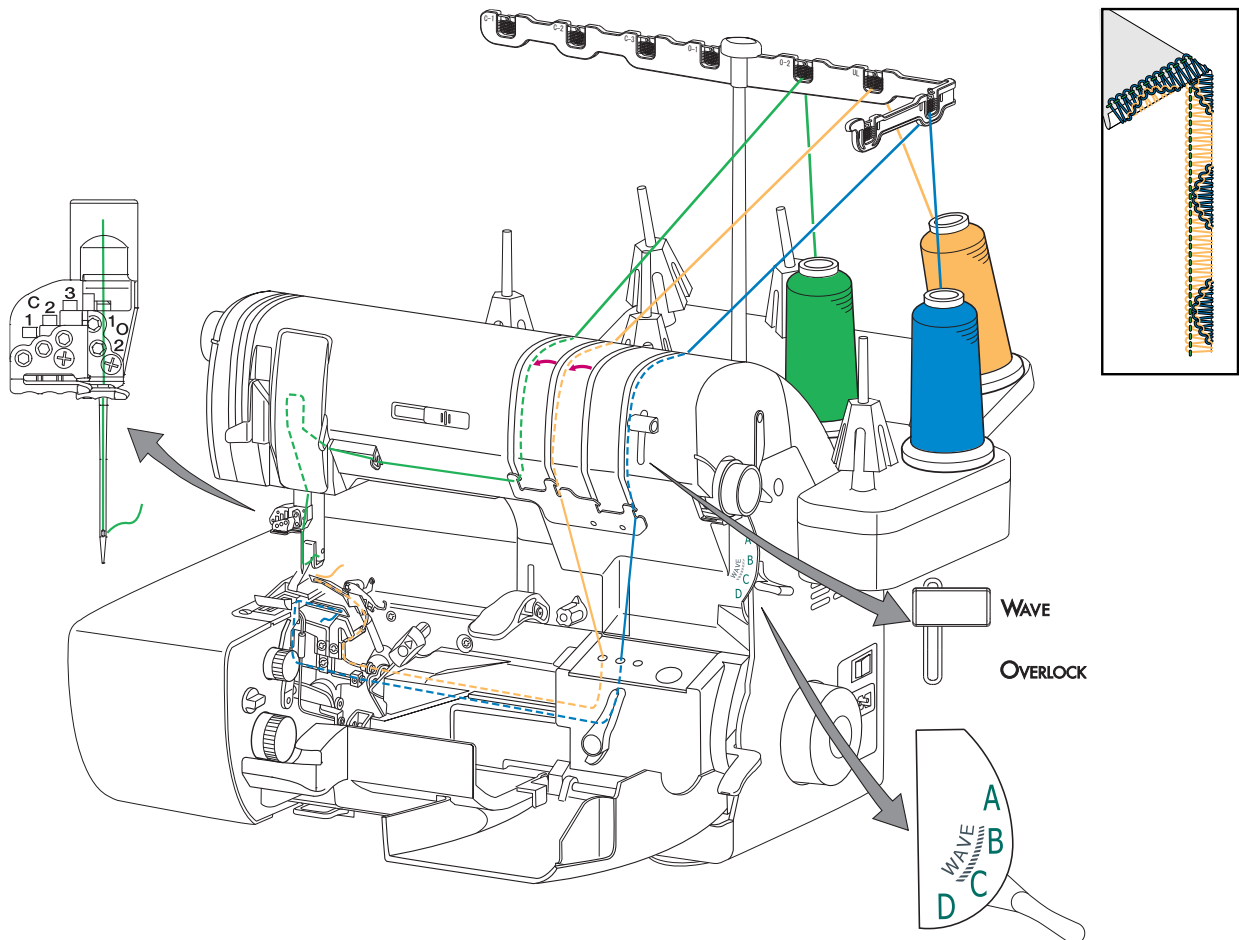

# 3-Thread Reversed Wave Stitch

You can also get the wave stitch in the back of fabric by crossing the upper and lower looper threads before the threading ports. This Reversed Wave Stitch is attractive for an expressive stitch with decorative cover stitches. (fig. A)

1. Move the Wave/Overlock Selector lever from "OVERLOCK" to "WAVE".
  2. Cut the threads from the thread cones, raise presser foot and remove threads from the thread paths.
  3. Engage the threading lever in threading position, for threading the loopers. (see page 19)
  4. Place the thread cone on the OVERLOCK NEEDLE 2 spool pin.
  5. Guide the thread through the telescopic thread guide "O-2" directly above the thread. Follow the "OVERLOCK NEEDLES 1" threading path down to the "O-2" overlock needle.
  6. Thread the O-2 needle using the needle threader. (see page 24)
  7. Place the thread cone on the UPPER LOOPER spool pin.
  8. Guide the thread through the telescopic antennae thread guide "UL" directly above the thread. Follow the "OVERLOCK NEEDLES 2" threading path for the UPPER LOOPER thread, down the front threading path, to the right of the chrome thread guide, and directly to the "L" threading port for the lower looper. Thread the lower looper. (see page 20)
- Note:** This upper looper thread which goes into lower looper through "L" threading port appears as wave stitch on the back side of fabric.
9. Place the thread cone on the LOWER LOOPER spool pin.
  10. Thread lower looper using standard lower looper threading technique. (Refer to Steps 2 - 6 on page 20) The only difference regarding standard threading is you use the "U" threading port instead of the "L" port.
  11. Place the "O-2" needle thread and the lower looper thread from the eye of the upper looper under the presser foot and to the back.
  12. Engage the threading lever in the serging position.
  13. Set Stitch Selector on "B" for Wave Stitch.
  14. Set Stitch Length and Stitch Width following the illustration below.

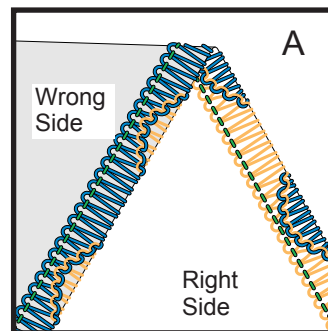

**Note:** It is not recommended to use reversed rolled wave.

| NEEDLES | LENGTH   | WIDTH | STITCH SELECTOR | WAVE/OVERLOCK SELECTOR |
|---------|----------|-------|-----------------|------------------------|
| O-2     | 0.75-2.5 | 5.0   | B               | WAVE                   |

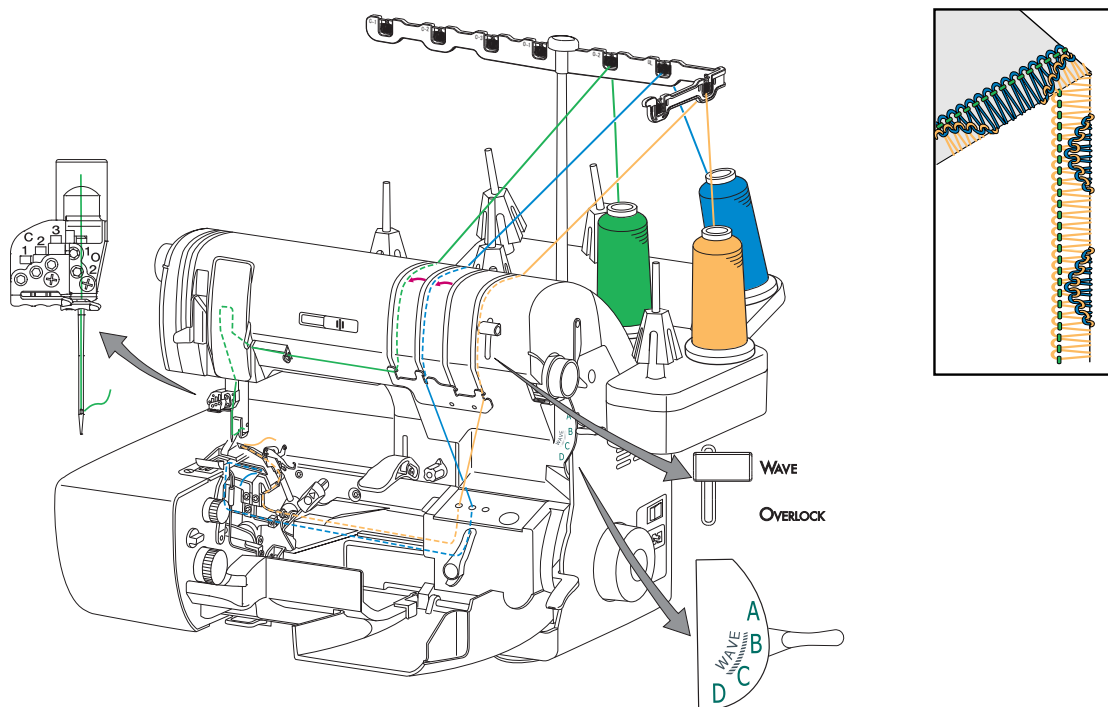

# Chain Stitching

The chain stitch is formed using two threads, one thread in the needle and one thread in the chain looper.

Chain Stitching looks like a straight stitch on the top of the fabric while the chain looper thread forms a chain on the underside of the fabric. The chain stitch has stretchability that is not found in the conventional locked straight stitch from a sewing machine. The chain stitch is used to stabilize seams in woven fabrics and where needed in knit fabrics. The chain stitch can also be used for sewing wide elastic in garments and applying bias tape.

**For Chain Stitch:**

1. Turn the cutting blade to the locked position.
2. Disengage the upper looper by turning the upper looper positioning knob to the "down" position.
3. Place the machine in threading position to thread the chain looper. (see page 19)
4. Follow the illustration to thread the chain looper (see page 45). Open side cover of machine to make sure the chain looper thread is laying inside tray. If necessary, trim thread to approximately 4 inches (10cm) and lay back inside tray.
5. Follow the illustration to thread the chain/cover stitch needle, (C-1, C-2, or C-3). Place needle thread on top and to the left of presser foot before sewing.
6. Set stitch length and other machine adjustments. (refer to chart below)
7. Engage the threading lever in serging position.
8. Remove the cutting blade cover and attach sewing table. (see page 10)
9. Place the fabric under the needle and turn handwheel toward you taking two or three stitches in the fabric. Cut the excess threads and start sewing.

**Note:** All chain and cover stitches must be started with fabric under the needle(s).

**CHAIN STITCH**

|                           |                     |                                       |  |
|---------------------------|---------------------|---------------------------------------|--|
| NEEDLES<br>C-1,C-2 or C-3 | LENGTH<br>2.0 - 4.0 | Set Needle Tension<br>Dial to:<br>4-6 | Set Chain Looper<br>Tension Dial to:<br>Chain Stitch * |
|---------------------------|---------------------|---------------------------------------|--|

\* When using C-1 needle, Chain looper tension may need to be set higher than middle position.

# Chain Stitching (Cont.)

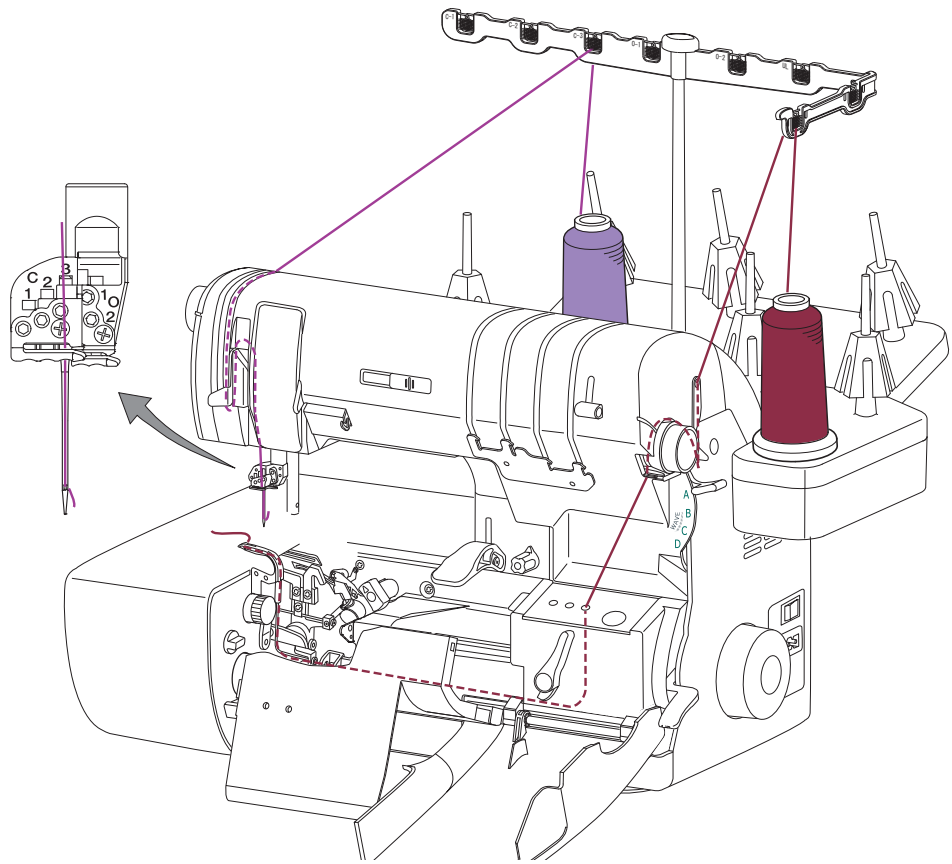
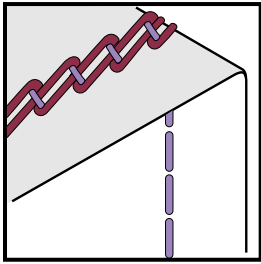

## \*Tension Adjustment

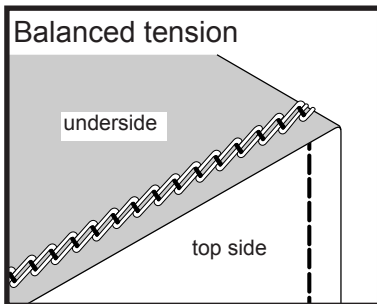

### Balanced tension -

Chain stitch has correct tension when the needle thread sews a straight seam on the top side and the chain looper thread forms loops on the underside of the fabric.

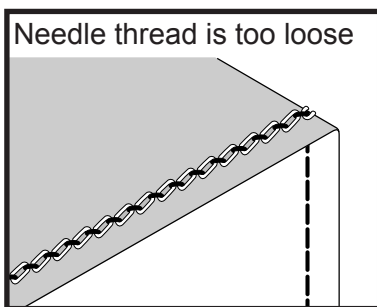

### Needle thread is too loose -

Turn the chain/cover stitch needle tension dial to a higher number. Or turn the chain/cover stitch looper tension dial to a narrower stripe for looser tension. (Narrow stripes are looser tension)

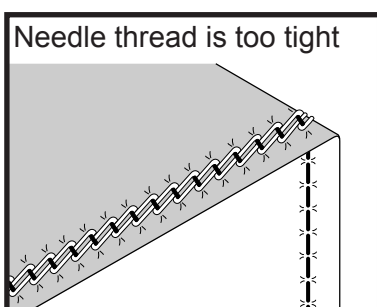

### Needle thread is too tight -

Turn the chain/cover stitch needle tension dial to a lower number. Or turn the chain/cover stitch looper tension dial to a wider stripe for tighter tension. (Wider stripes are tighter tension)

# Cover Stitch - Right Narrow - 3mm

The narrow cover stitch consists of two rows of straight stitching on the top side of the fabric with an overlock stitch on the underside of the fabric. This stitch is very common in the garment industry to hem knit garments. The narrow cover stitch is used on fine knits such as jersey and single knits for hemming or topstitching. The cover stitch is not limited to knit fabrics. It also works well with woven fabrics.

The Right Narrow Cover Stitch is formed using two "C" needle positions and the chain looper. The needle positions are C-2 and C-3. The width of the narrow cover stitch is 3mm.

**For Cover Stitch:**

1. Turn the cutting blade to the "locked" position.
2. Disengage the upper looper by turning the upper looper positioning knob to the "down" position.
3. Place the machine in threading position to thread the chain looper. (see page 19)
4. Follow the illustration to thread the chain looper. (see page 21) Open the side cover toward the left for easy access to chain looper thread tray. If necessary, trim thread to approximately 4 inches (10cm) and lay thread back inside the tray.
5. Follow the illustration to thread the chain/cover stitch needles C-2 and C-3. (see page 22) Place needle threads on top and to the left of presser foot before sewing.
6. Set stitch length and other machine adjustments. (refer to chart below)
7. Engage the threading lever in the serging position.
8. Remove the cutting blade cover and attach the sewing table. (page 10)
9. Place the fabric under the needles and turn handwheel toward you taking two or three stitches into the fabric. Cut the excess threads and start sewing.

**Note:** All chain and cover stitches must be started with fabric under the needle(s).

**COVER STITCH - RIGHT NARROW**

|                        |                     |                                       |  |
|------------------------|---------------------|---------------------------------------|--|
| NEEDLES<br>C-2 and C-3 | LENGTH<br>2.0 - 4.0 | Set Needle Tension<br>Dial to:<br>4-6 | Set Chain Looper<br>Tension Dial to:<br>Cover Stitch |
|------------------------|---------------------|---------------------------------------|--|

# Cover Stitch - Right Narrow (Cont.)

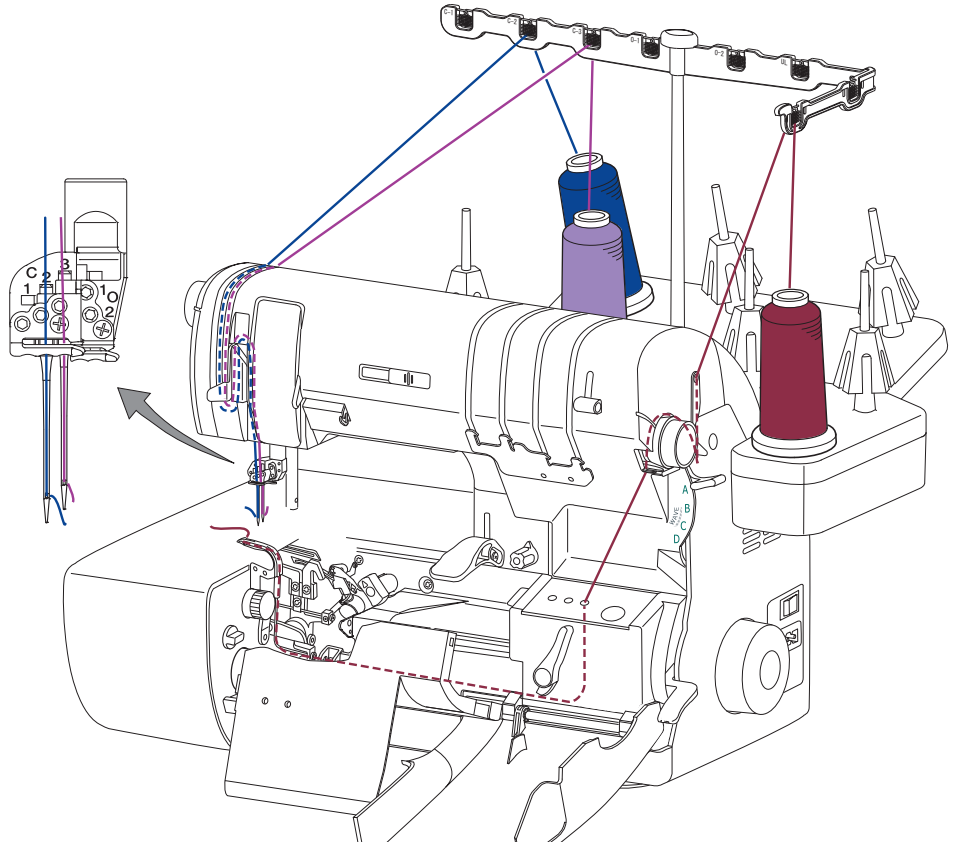
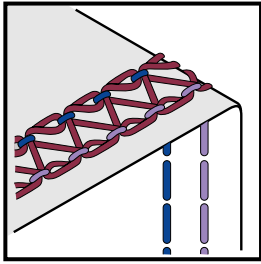

## \*Tension Adjustment

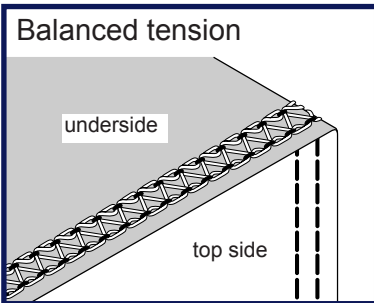

### Balanced tension -

Cover stitch has correct tension when the needle thread sews two rows of straight stitching on the top side and the chain looper forms a zigzag on the underside of the fabric.

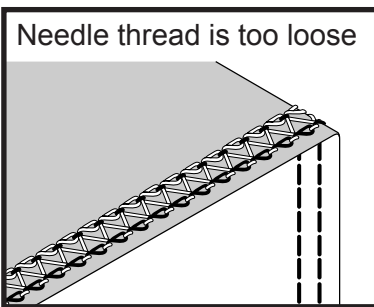

### Needle thread is too loose -

Turn the chain /cover stitch needle tension dial to a higher number.

Or turn the chain/cover stitch looper tension dial away from the wide stripe at the words "Cover Stitch", but staying within the solid gold line. This will tighten the chain looper thread on the underside of the stitch.

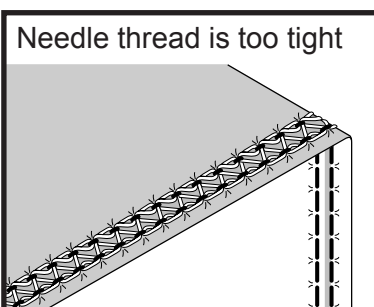

### Needle thread is too tight -

For a looser tension turn the chain /cover stitch needle tension dial to a lower number. Make sure that the chain/cover stitch looper tension dial is set at the solid stripe with the words "Cover Stitch".

# Cover Stitch - Left Narrow - 3mm

The narrow cover stitch consists of two rows of straight stitching on the top side of the fabric with the overlock stitch on the underside of the fabric. This stitch is very common in the garment industry to hem knit garments. The narrow cover stitch is used on fine knits such as jersey and single knits for hemming or topstitching. The cover stitch is not limited to knit fabrics. It also works well with woven fabrics.

The Left Narrow Cover Stitch is formed using two "C" needle positions and the chain looper. The needle positions are C-1 and C-2. The width of the narrow cover stitch is 3mm.

**For Cover Stitch:**

1. Turn the cutting blade to the locked position.
2. Disengage the upper looper by turning the upper looper positioning knob to the "down" position.
3. Place the machine in threading position to thread the chain looper. (see page 19)
4. Follow the illustration to thread the chain looper. Open the side cover toward the left for easy access to chain looper thread tray. If necessary, trim thread to approximately 4 inches (10cm) and lay thread back inside the tray.
5. Follow the illustration to thread the chain/cover stitch needle positions C-1 and C-2. Place needle threads on top and to the left of presser foot before sewing.
6. Set stitch length and other machine adjustments. (refer to chart below)
7. Engage the threading lever in the serging position.
8. Remove the cutting blade cover and attach the sewing table. (see page 10)
9. Place the fabric under the needles and turn handwheel toward you taking two or three stitches into the fabric. Cut the excess threads and start sewing.

**Note:** All chain and cover stitches must be started with fabric under the needle(s).

**COVER STITCH - LEFT NARROW**

|                        |                     |                                       |  |
|------------------------|---------------------|---------------------------------------|--|
| NEEDLES<br>C-1 and C-2 | LENGTH<br>2.0 - 4.0 | Set Needle Tension<br>Dial to:<br>4-6 | Set Chain Looper<br>Tension Dial to:<br>Cover Stitch |
|------------------------|---------------------|---------------------------------------|--|

# Cover Stitch - Left Narrow (Cont.)

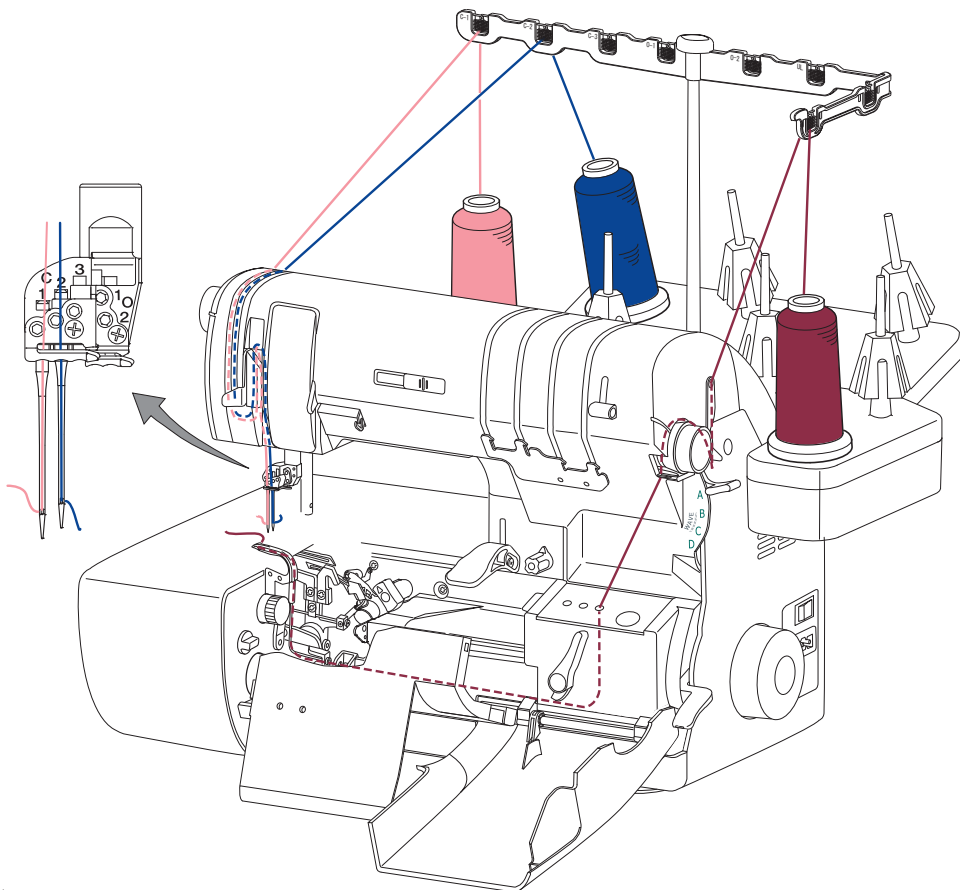
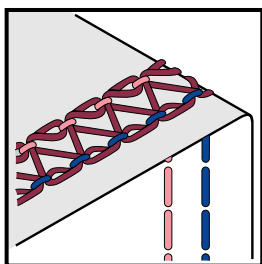

## \*Tension Adjustment

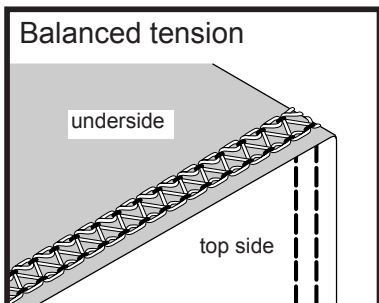

### Balanced tension -

Cover stitch has correct tension when the needle thread sews two rows of straight stitching on the top side of the fabric and the chain looper forms a zigzag on the underside of the fabric.

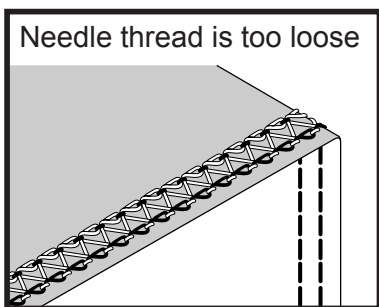

### Needle thread is too loose -

Turn the chain /cover stitch needle tension dial to a higher number.

Or turn the chain/cover stitch looper tension dial away from the wide stripe at the words "Cover Stitch", but staying within the solid gold line. This will tighten the chain looper thread on the underside of the stitch.

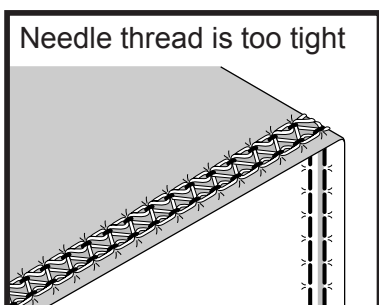

### Needle thread is too tight -

For a looser tension turn the chain /cover stitch needle tension dial to a lower number. Make sure that the chain/cover stitch looper tension dial is set at the solid stripe with the words "Cover Stitch".

# Cover Stitch - Wide - 6mm

The wide cover stitch consists of two rows of straight stitching on top the fabric with an overlock stitch on the underside of the fabric. This stitch is very common in the garment industry to hem heavier knit fabrics such as double knits, sweatshirt fleece, and polar fleece. The wide cover stitch is not limited to knit fabrics. It also works well with medium to heavy woven fabrics.

The Wide Cover Stitch is formed using two "C" needle positions and the chain looper. The needle positions are C-1 and C-3. The width of the wide cover stitch is 6mm.

**For Cover Stitch:**

1. Turn the cutting blade to the "locked" position.
2. Disengage the upper looper by turning the upper looper positioning knob to the "down" position.
3. Place the machine in threading position to thread the chain looper. (see page 19)
4. Follow the illustration to thread the chain looper. Open the side cover toward the left for easy access to chain looper thread tray. If necessary, trim thread to approximately 4 inches (10cm) and lay thread back inside the tray.
5. Follow the illustration to thread the chain/cover stitch needle positions C-1 and C-3. Place needle threads on top and to the left of presser foot before sewing.
6. Set stitch length and other machine adjustments. (refer to chart below)
7. Engage the threading lever in the serging position.
8. Remove the cutting blade cover and attach the sewing table. (see page 10)
9. Place the fabric under the needles and turn handwheel toward you taking two or three stitches in the fabric. Cut the excess threads and start sewing.

**Note:** All chain and cover stitches must be started with fabric under the needle(s).

**COVER STITCH - WIDE**

|                        |                     |                                       |  |
|------------------------|---------------------|---------------------------------------|--|
| NEEDLES<br>C-1 and C-3 | LENGTH<br>2.0 - 4.0 | Set Needle Tension<br>Dial to:<br>4-6 | Set Chain Looper<br>Tension Dial to:<br>Cover Stitch |
|------------------------|---------------------|---------------------------------------|--|

# Cover Stitch - Wide - 6mm (Cont.)

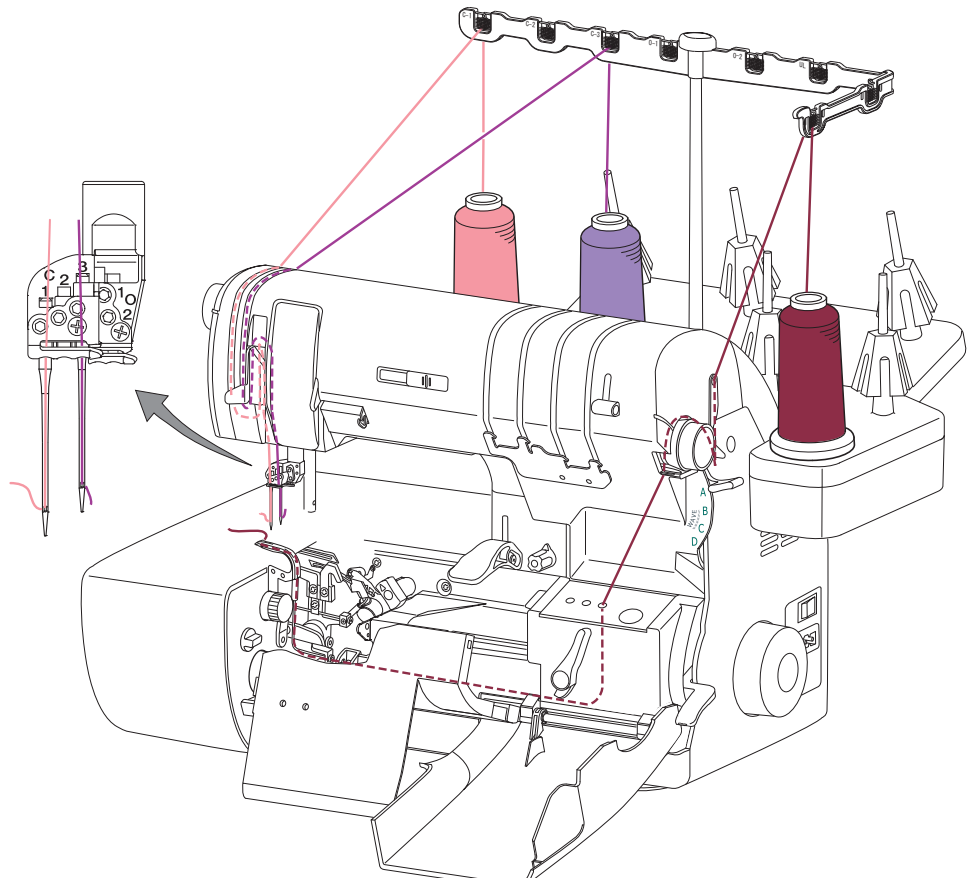
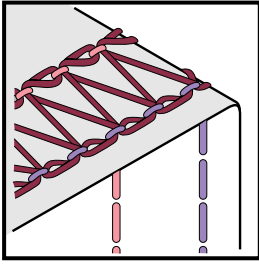

## \*Tension Adjustment

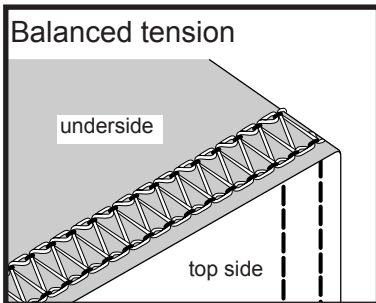

### Balanced tension -

Cover stitch has correct tension when the needle thread sews two rows of straight stitching on the top side and the chain looper forms a zigzag on the underside of the fabric.

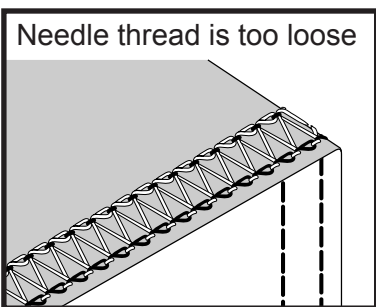

### Needle thread is too loose -

Turn the chain/cover stitch needle tension dial to a higher number. Or turn the chain / cover stitch looper tension dial away from the wide stripe at the words "Cover Stitch", but staying within the solid gold line. This will tighten the chain looper thread on the underside of the stitch.

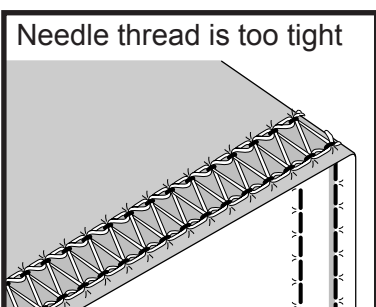

### Needle thread is too tight -

For a looser tension turn the chain / cover stitch needle tension dial to a lower number. Make sure that the chain / cover stitch looper tension dial is set at the solid stripe with the words "Cover Stitch".

# Triple Cover Stitch - 6mm

The Triple Cover Stitch can be used for topstitching, hemming, and elastic application . The stitch can also be used as a decorative stitch upside down with the overlock side on the right side of the fabric. The garment industry uses the Triple Cover Stitch frequently in activewear.

The Triple Cover Stitch is formed using all three "C" needle positions and the chain looper. The Triple Cover Stitch is made up of three rows of straight stitching on the top of the fabric with the chain looper forming an overlock stitch on the underside of the fabric.

**For Triple Cover Stitch:**

1. Turn the cutting blade to the "locked" position.
2. Disengage the upper looper by turning the upper looper positioning knob to the "down" position.
3. Place the machine in threading position to thread the chain looper. (see page 19)
4. Follow the illustration to thread the chain looper. Open the side cover toward the left for easy access to chain looper thread tray. If necessary, trim thread to approximately 4 inches (10cm) and lay thread back inside the tray.
5. Follow the illustration to thread the chain/cover stitch needle positions C-1, C-2 and C-3. Place needle threads on top and to the left of presser foot before sewing.
6. Set stitch length and other machine adjustments. (refer to chart below)
7. Engage the threading lever in the serging position.
8. Remove the cutting blade cover and attach the sewing table. (see page 10)
9. Place the fabric under the needles and turn handwheel toward you taking two or three stitches in the fabric. Cut the excess threads and start sewing.

**Note:** All chain and cover stitches must be started with fabric under the needle(s).

**TRIPLE COVER STITCH**

|                             |                     |                                       |  |
|-----------------------------|---------------------|---------------------------------------|--|
| NEEDLES<br>C-1, C-2 and C-3 | LENGTH<br>2.0 - 4.0 | Set Needle Tension<br>Dial to:<br>4-6 | Set Chain Looper<br>Tension Dial to:<br>Cover Stitch |
|-----------------------------|---------------------|---------------------------------------|--|

# Triple Cover Stitch (Cont.)

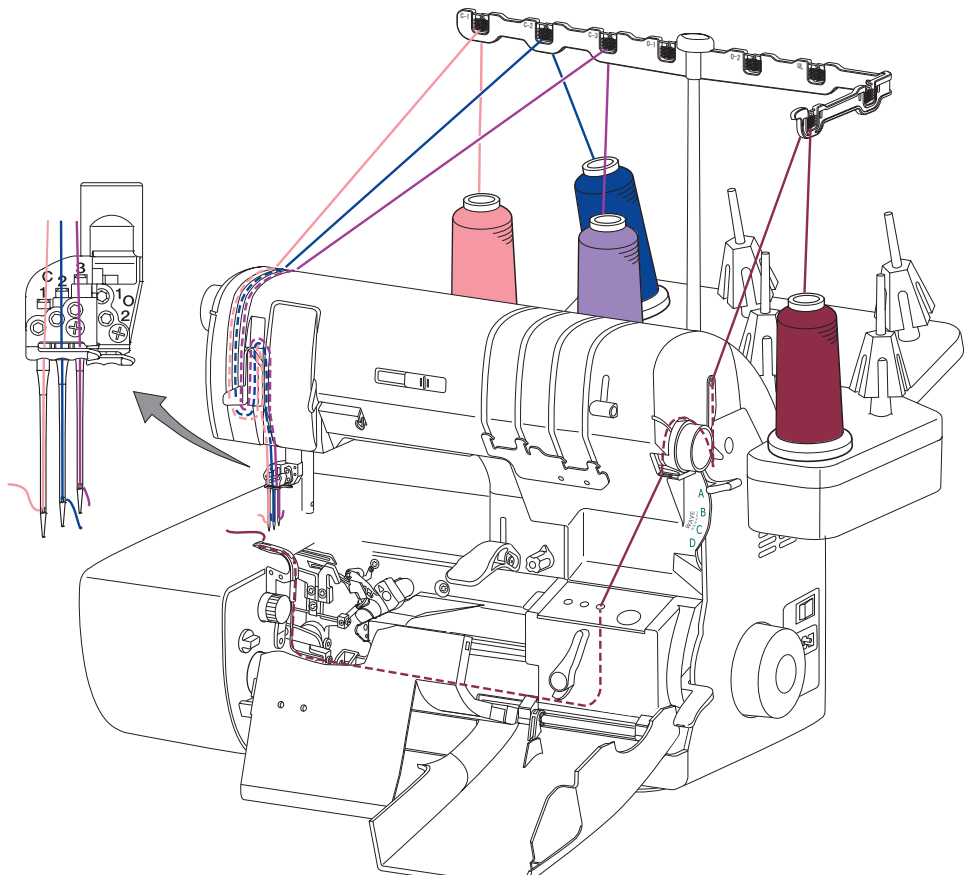
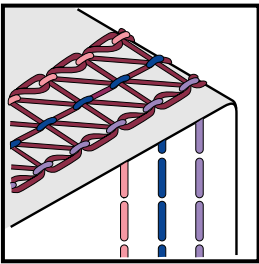

**\*Tension Adjustment**

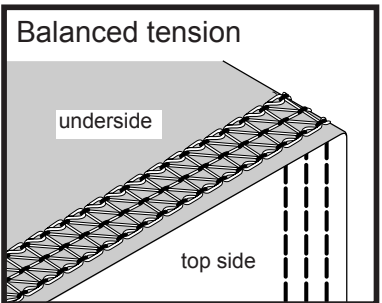

**Balanced tension -**  
Triple Cover stitch has correct tension when the needle thread sew three rows of straight stitching on the top side and the chain looper forms a zigzag on the underside of the fabric.

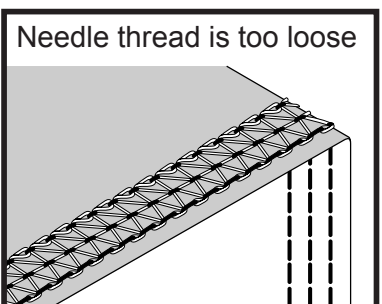

**Needle thread is too loose -**  
Turn the chain/cover stitch needle tension dial to a higher number. Or turn the chain / cover stitch looper tension dial away from the wide stripe at the words "Cover Stitch", but staying within the solid gold line. This will tighten the chain looper thread on the underside of the stitch.

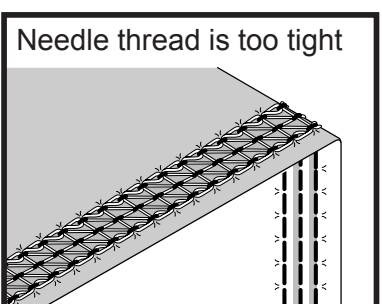

**Needle thread is too tight -**  
For a looser tension turn the chain / cover stitch needle tension dial to a lower number. Make sure that the chain / cover stitch looper tension dial is set at the solid stripe with the words "Cover Stitch".

## 4-Thread Safety Stitch

The 4-thread safety stitch is perfect for all types of woven fabrics ranging from fine to heavy weight fabrics. This stitch is designed to seam and overlock the edge in one step, thus creating a garment industry standard safety stitch. As well as woven fabrics, the 4-thread safety stitch is for stabilizing knits, sweater knits and long seams on woven fabrics.

4-thread safety stitch is a combined stitch of a 2-thread overlock using subsidiary looper on the upper looper and a 2-thread chain stitch. The 4-thread safety stitch itself can be 3 different seam widths, depending on the chain/cover stitch needle position.

The varied widths can then work with different types of fabrics.

### For 4-thread Safety Stitch:

1. Use standard cutting blade cover.
2. Thread the lower and chain loopers.
3. Thread one chain needle and the O-1 overlock needle. (see illustration)
4. Engage the subsidiary looper in the upper looper.
5. Engage the upper blade to cut the fabric. Set stitch width dial at 7.5."
6. Select "A" on the Stitch Selector.
7. Set Wave/Overlock Selector Lever on "OVERLOCK".

\* For each size refer to settings chart on next page for the 4-thread safety stitch.

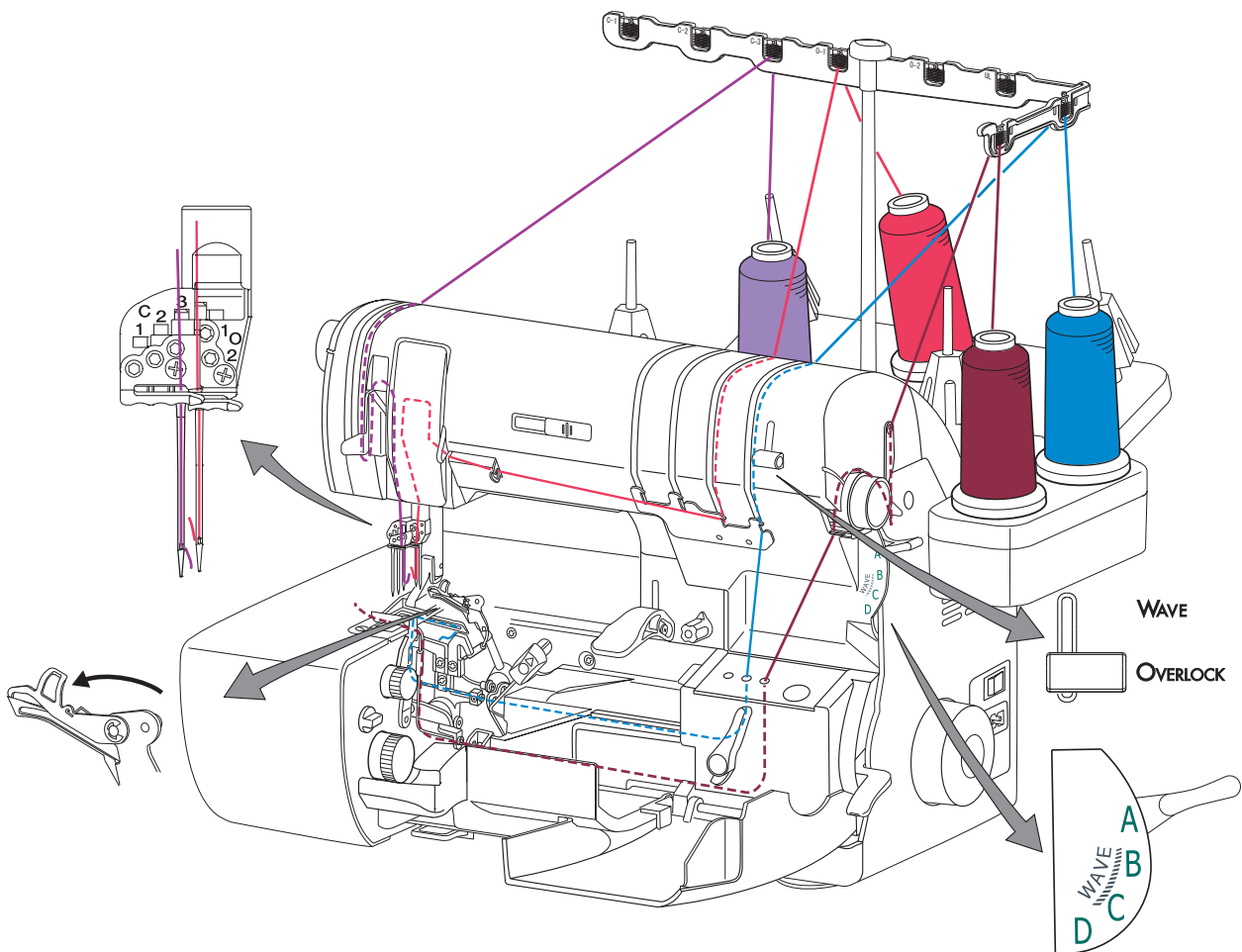

# 4-Thread Safety Stitch (Cont.)

## 4-Thread Safety Stitch:

2-Thread Chain w/2-Thread Wide Overlock

5/8 inch (16mm)

1/2 inch (13mm)

3/8 inch (9.5mm)

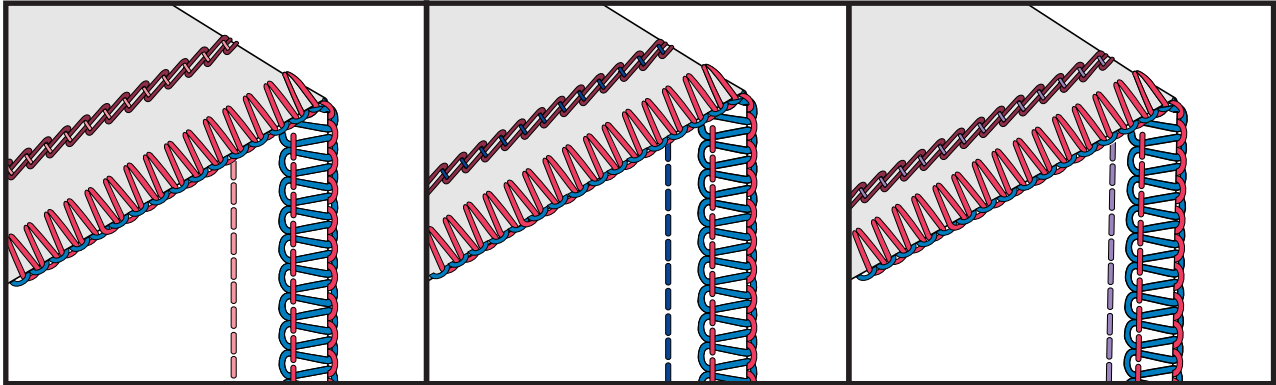

| Size             | Needle   | Looper          | Stitch Length | Stitch Width | Stitch Selector | Chain Needle Tension Dial | Chain Looper Tension Dial |
|------------------|----------|-----------------|---------------|--------------|-----------------|---------------------------|---------------------------|
| 5/8 inch (16mm)  | C-1, O-1 | C,L, Sub Looper | 2.5-4.0       | 7.5          | A               | 4-6                       | Chain Stitch              |
| 1/2 inch (13mm)  | C-2, O-1 | C,L, Sub Looper | 2.5-4.0       | 7.5          | A               | 4-6                       | Chain Stitch              |
| 3/8 inch (9.5mm) | C-3, O-1 | C,L, Sub Looper | 2.5-4.0       | 7.5          | A               | 4-6                       | Chain Stitch              |

**Note:** Stitch length, stitch width and chain needle tension settings may vary with different types of thread and fabric.

## 5-Thread Safety Stitch

The 5-thread safety stitch is perfect for all types of woven fabrics ranging from fine to heavy weight. This stitch is designed to seam and overlock the edge in one step, thus creating a garment industry standard stitch. As well as woven fabrics, the 5-thread safety stitch is for stabilizing knits, sweater knits and long seams on woven fabrics.

The 5-thread safety stitch is a combined stitch of a 3-thread overlock and 2-thread chain stitch. The 5-thread safety stitch itself can be up to 3 different seam widths, depending on the chain/cover stitch needle position. The varied widths can then work with different types of fabrics.

### For 5-Thread Safety Stitch:

1. Use standard cutting blade cover.
2. Thread the upper, lower and chain loopers.
3. Thread one chain needle and O-1 overlock needle. (See illustration)
4. Engage the upper blade to cut the fabric. Set stitch width dial at 7.5.
5. Select "A" on the Stitch Selector.
6. Set Wave/Overlock Selector Lever on "OVERLOCK".

\* For each size refer to settings chart on next page for the 5-thread safety stitch.

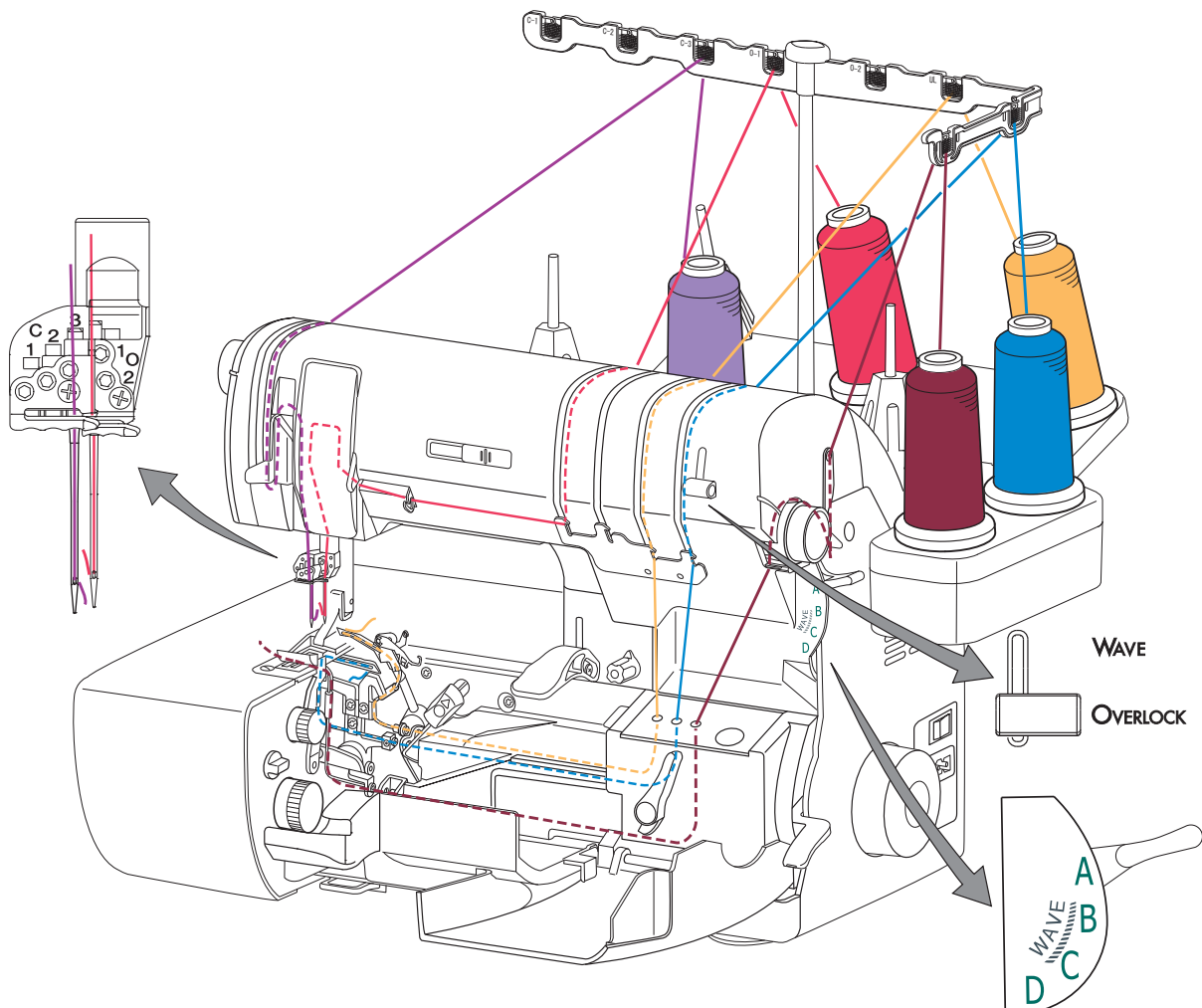

# 5-Thread Safety Stitch (Cont.)

**5-Thread Safety Stitch:**  
2-Thread Chain w/3-Thread wide Overlock

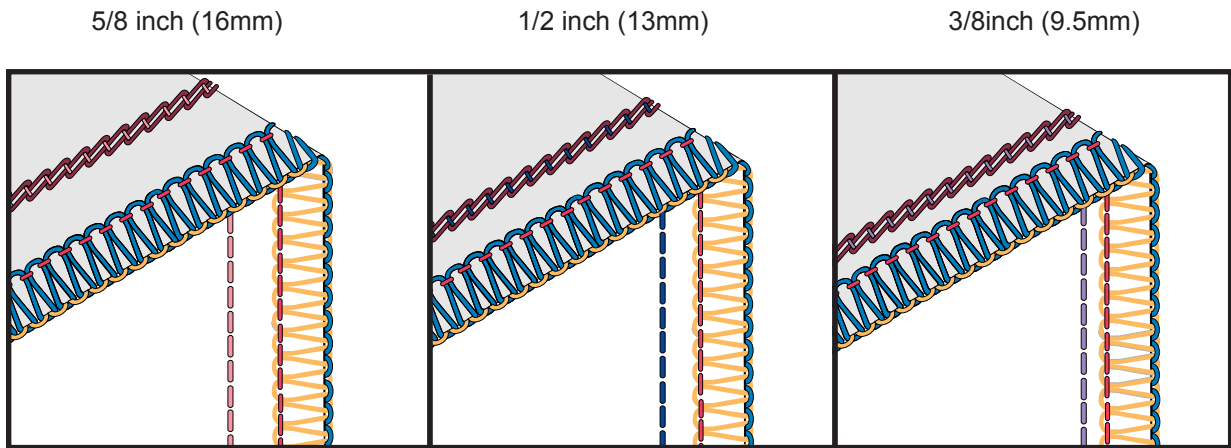

| Size             | Needle   | Looper | Stitch Length | Stitch Width | Stitch Selector | Chain Needle Tension Dial | Chain Looper Tension Dial |
|------------------|----------|--------|---------------|--------------|-----------------|---------------------------|---------------------------|
| 5/8 inch (16mm)  | C-1, O-1 | U,L,C  | 2.5-4.0       | 7.5          | A               | 4-6                       | Chain Stitch              |
| 1/2 inch (13mm)  | C-2, O-1 | U,L,C  | 2.5-4.0       | 7.5          | A               | 4-6                       | Chain Stitch              |
| 3/8 inch (9.5mm) | C-3, O-1 | U,L,C  | 2.5-4.0       | 7.5          | A               | 4-6                       | Chain Stitch              |

**\*Note:** Stitch length, stitch width and chain needle tension settings may vary with different types of thread and fabric.

# 7-Thread Wave Stitch

7-Thread Wave Stitch is a combined stitch of 3-Thread Wave and 4-Thread Triple Cover Stitch. This stitch looks gorgeous with decorative threads appearing on wave stitch and triple cover stitch.

## For the 7-Thread Wave Stitch:

1. Use standard cutting blade cover.
2. Thread upper looper according to either 3-thread wave stitch or 3-thread rolled wave stitch. (see page 41 or 42) Thread the lower looper in the standard lower looper thread path (illustration below).
3. Thread chain looper.
4. Thread C-1, C-2, C-3, and O-2 (overlock) needle positions.
5. Engage the upper blade to cut the fabric.
6. Select "B" on the Stitch Selector for 3-thread wave. (Select C for 3-thread rolled wave.)
7. Move the Wave/Overlock Selector lever from "OVERLOCK" to "WAVE".

The stitch selection charts in the back of the manual have other combination of stitches such as:

- 6-Thread Wave - wide (cover stitch wide with 3-thread wave)
  - 6-Thread Wave - narrow (cover stitch narrow with 3-thread wave)
  - 5-Thread Wave - (chain stitch with 3-thread wave)
- (For proper settings, see chart on page 88/89)

All these stitch combinations work in the same manner as the 7-Thread Wave Stitch. See next page for illustrations of the various stitch combinations.

**Note:** Due to the change in the O-2 and upper looper telescopic antennae thread paths, always sew the 7-thread Wave Stitch at a slow speed.

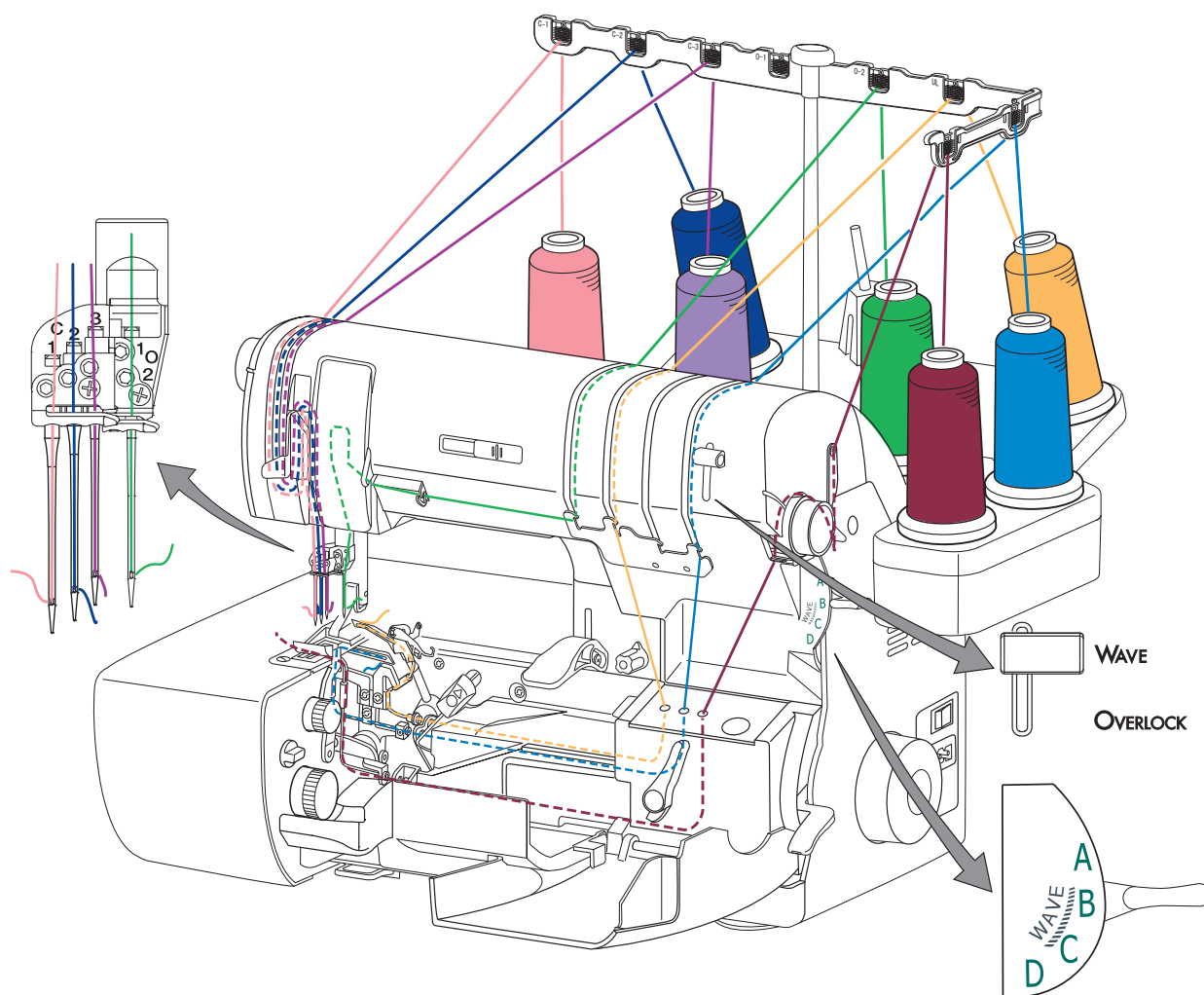

# 7-Thread Wave Stitch (Cont.)

## Variations of Stitches

**7-Thread Stitch**  
Triple Cover Stitch  
w/ 3-Thread Wave Stitch

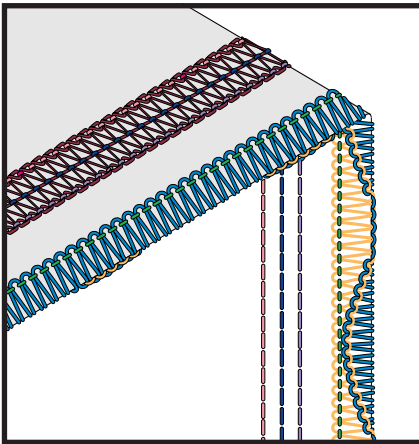

**6-Thread Stitch**  
Cover Stitch Wide  
w/ 3-Thread Wave Stitch

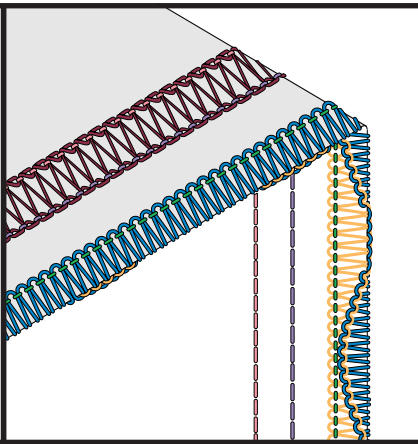

**6-Thread Stitch**  
Cover Stitch Wide  
w/ 3-Thread Rolled Wave

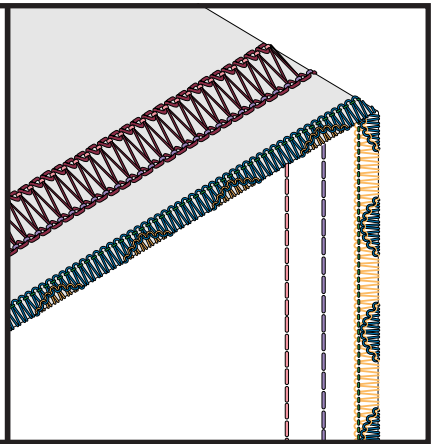

**6-Thread Stitch**  
Cover Stitch Narrow Left  
w/ 3-Thread Rolled Wave

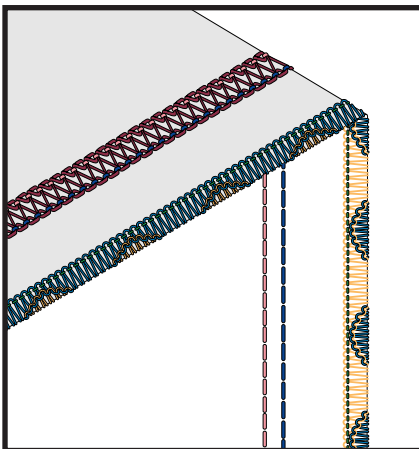

**5-Thread Stitch**  
Right Chain Stitch  
w/3-Thread Wave Stitch

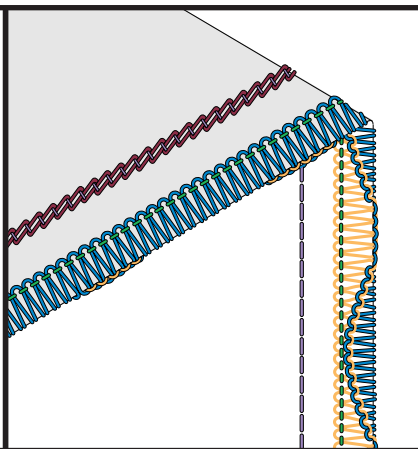

**5-Thread Stitch**  
Right Chain Stitch  
w/3-Thread Rolled Wave

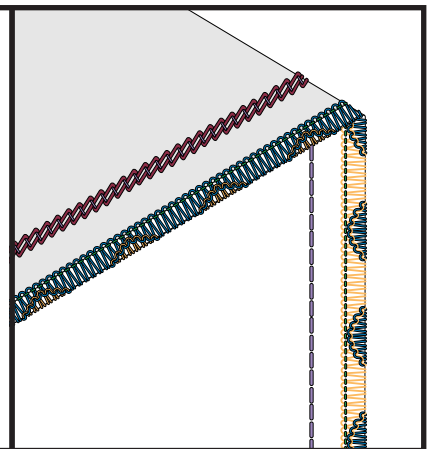

# 7-Thread Reversed Wave Stitch

7-Thread Reversed Wave Stitch is a combined stitch of 3-Thread Reverse Wave and 4-Thread triple cover stitch. This stitch looks gorgeous with decorative threads appearing on wave stitch and triple cover stitch in the back of fabric.

## For the 7-Thread Reversed Wave Stitch:

1. Use standard cutting blade cover.
2. Thread upper and lower loopers for the 3-thread reversed wave stitch. (see page 43)
3. Thread chain looper.
4. Thread C-1, C-2, C-3, and O-2 (overlock) needle positions.
5. Engage the upper blade to cut the fabric.
6. Select "B" using the Stitch Selector Lever.
7. Set the Wave/Overlock Selector lever from "OVERLOCK" to "WAVE".

The stitch selection charts in the back of the manual have other combination of stitches such as:

- 6-Thread Reversed Wave - wide (cover stitch wide with 3-thread reverse wave)
  - 6-Thread Reversed Wave - narrow (cover stitch narrow with 3-thread reverse wave)
  - 5-Thread Reversed Wave - (chain stitch with 3-thread reverse wave)
- (For recommended settings, see chart on pages 88 and 89)

All these stitch combinations work in the same manner as the 7-Thread Reversed Wave Stitch. See next page for illustrations of the various stitch combinations.

**Note:** Due to the change in the O-2 and upper looper telescopic antennae thread paths, always sew the 7-thread Reversed Wave Stitch at a slow speed.

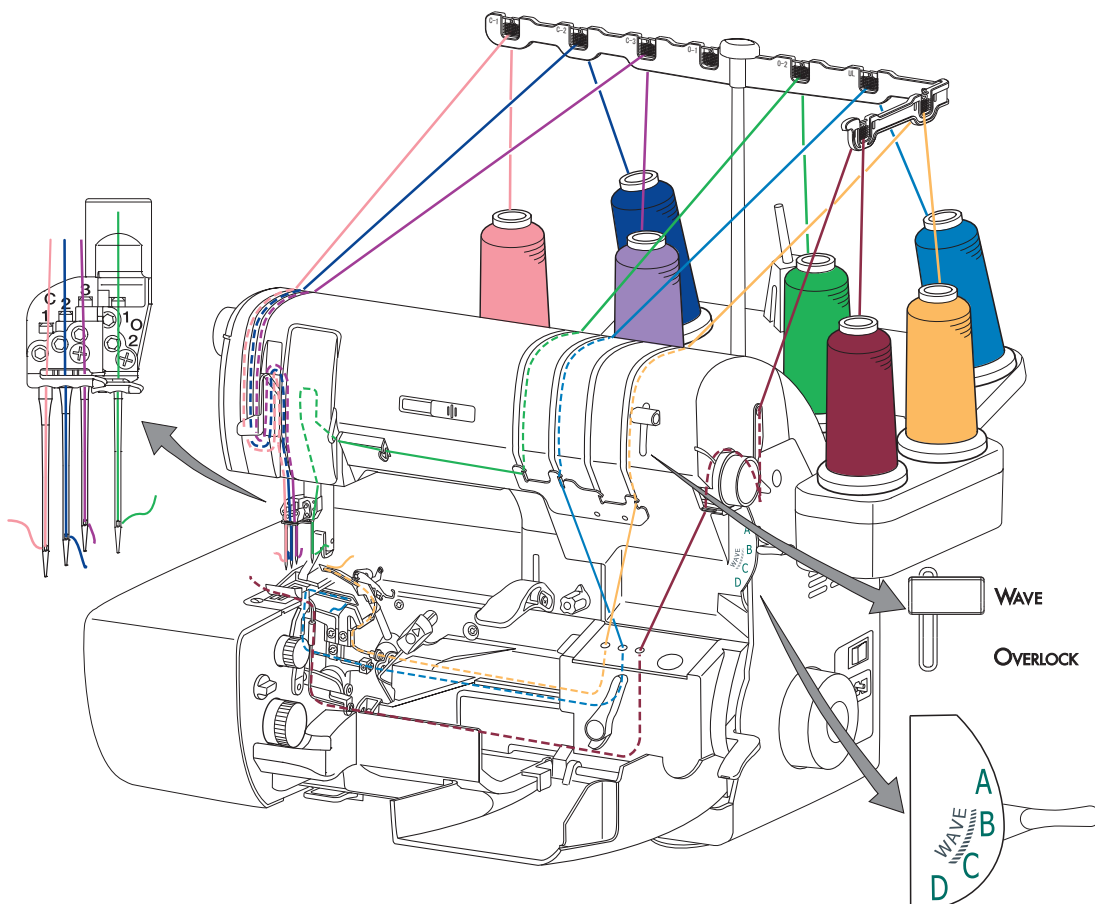

# 7-Thread Reversed Wave Stitch (Cont.)

## Variations of Stitches

**7-Thread Stitch**  
Triple Cover Stitch  
w/ 3-Thread Reversed  
Wave Stitch

**6-Thread Stitch**  
Cover Stitch Wide  
w/ 3-Thread Reversed  
Wave Stitch

**5-Thread Stitch**  
Right Chain Stitch  
w/ 3-Thread Reversed  
Wave Stitch

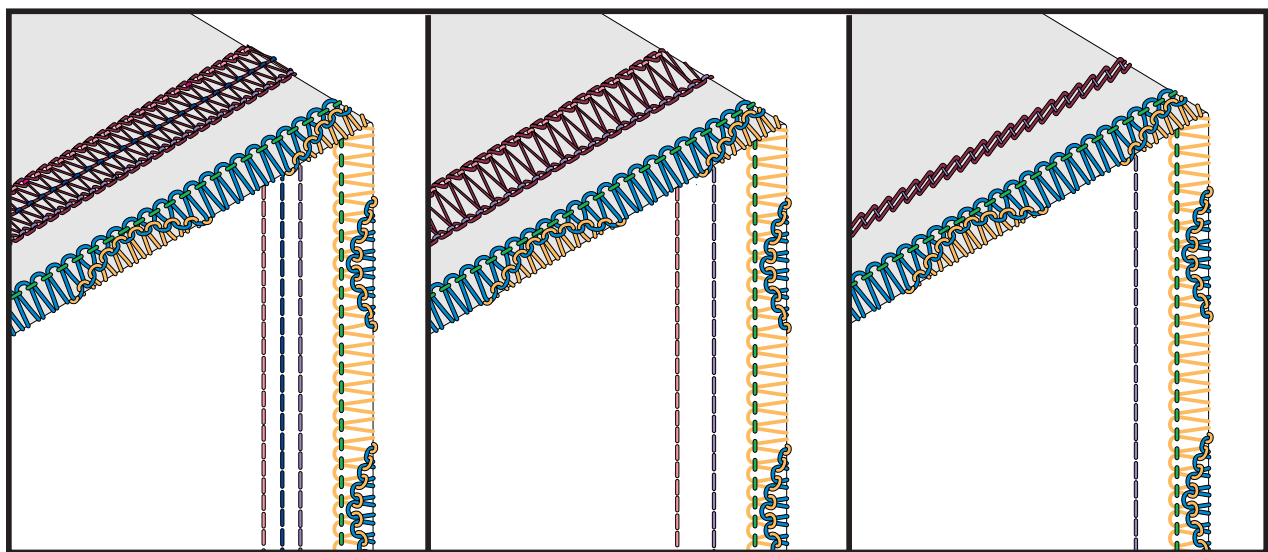

# 8-Thread Stitch

8-Thread Stitch is a combined stitch of 4-Thread Overlock and 4-Thread Triple Cover Stitch. The 8-thread stitch is perfect for garment construction on heavy weight woven fabrics and used as a decorative topstitching with decorative overlock edge finish. The stitch is very durable as well as being a decorative stitch. The stitch width is 5/8 inch (16.0mm) wide.

## For the 8-Thread Stitch:

1. Use standard cutting blade cover.
2. Thread upper, lower, and chain loopers.
3. Thread C-1, C-2, C-3, O-1, and O-2 needle positions.
4. Engage the upper blade to cut the fabric.
5. Select "A" using the Stitch Selector Lever.
6. Set Wave / Overlock Selector Lever on "OVERLOCK".

The stitch selection charts in the back of the manual have other combination of stitches such as:

- 7-Thread - wide (Triple Cover Stitch with 3-Thread Overlock Wide)
- 7-Thread - narrow (Triple Cover Stitch with 3-Thread Overlock Narrow)
- 6-Thread - wide (Wide Cover Stitch with 3-Thread Overlock Wide)
- 6-Thread - narrow (Narrow Cover Stitch with 3-Thread Overlock Narrow)

All these stitch combinations work in the same manner as the 8-Thread Stitch. See next page for illustrations of the various stitch combinations.

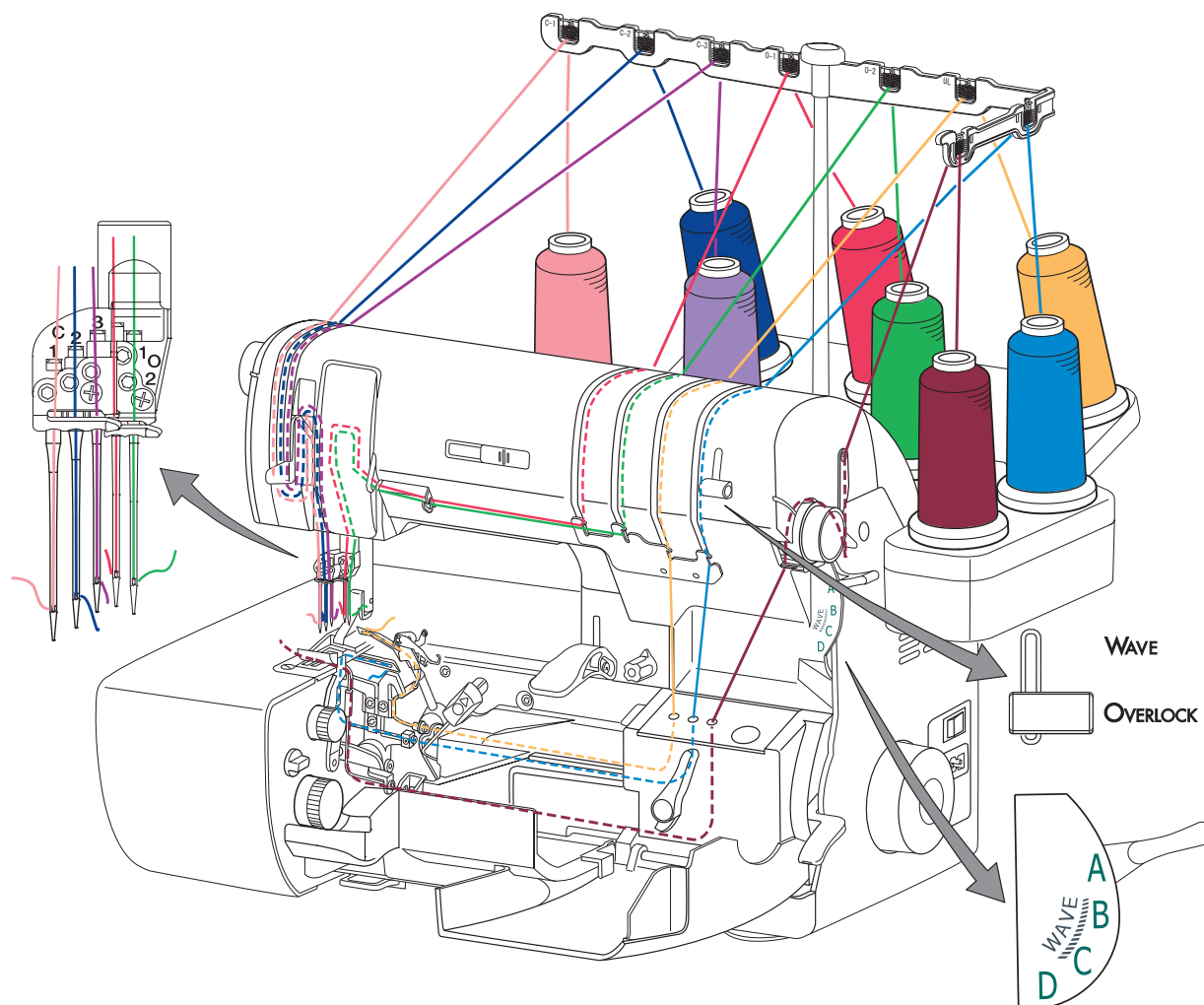

# 8-Thread Stitch (Cont.)

## Variations of Stitches

**8-Thread Stitch**  
Triple Cover Stitch  
w/ 4-Thread Overlock

**7-Thread - wide**  
Triple Cover Stitch  
w/3-Thread Overlock Wide

**7-Thread - narrow**  
Triple Cover Stitch  
w/3-Thread Overlock Narrow

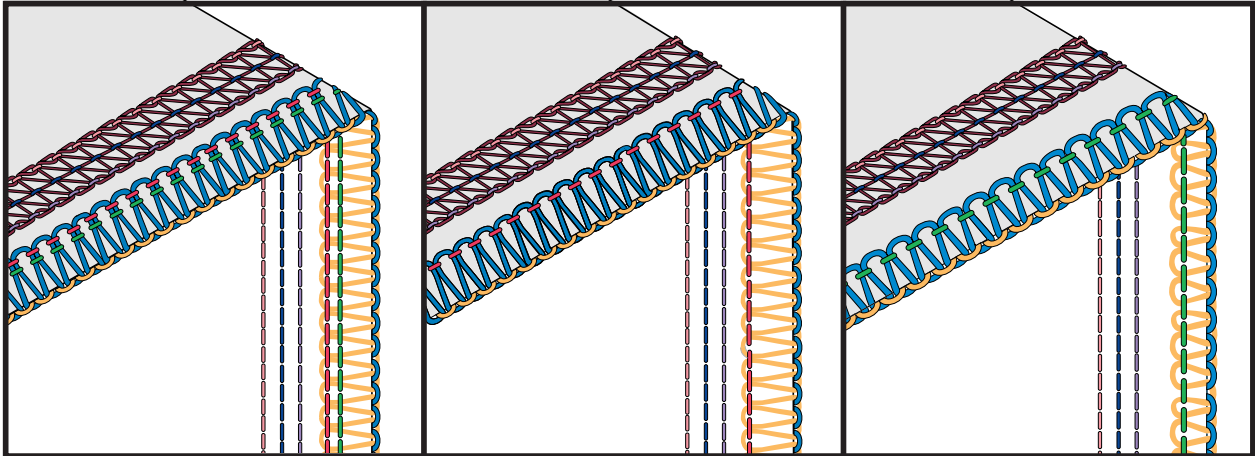

## Expressive Stitches: Chain/Cover Stitches Combined with Overlock Stitches

With the great features of Overlock Stitching and Chain/Cover Stitching on the Ovation, many different stitches branch off from the basic "Express" stitches. The following combinations can let you "Express" your creativity as never before.

Use the "Stitch Selection Chart" at the back of the manual for threading your Ovation with the different combinations.

The most common used combinations are the:

8-Thread Stitch - 4-Thread Overlock & Triple Cover Stitch

5-Thread Safety Stitch - 3-Thread Overlock & Chain Stitch C-3 needle position

4-Thread Safety Stitch - 2-Thread Overlock & Chain Stitch C-3 needle position

### "Expressive" Combinations:

4-Thread Overlock & Chain C-3 needle position

4-Thread Overlock & Chain C-2 needle position

4-Thread Overlock & Chain C-1 needle position

4-Thread Overlock & Right Narrow Cover Stitch

4-Thread Overlock & Left Narrow Cover Stitch

4-Thread Overlock & Wide Cover Stitch

4-Thread Overlock & Triple Cover Stitch

3-Thread Overlock Narrow & Chain C-3 needle position

3-Thread Overlock Narrow & Chain C-2 needle position

3-Thread Overlock Narrow & Chain C-1 needle position

3-Thread Overlock Narrow & Right Narrow Cover Stitch

3-Thread Overlock Narrow & Left Narrow Cover Stitch

3-Thread Overlock Narrow & Wide Cover Stitch

3-Thread Overlock Narrow & Triple Cover Stitch

3-Thread Wave Stitch & Chain C-3 needle position

3-Thread Wave Stitch & Chain C-2 needle position

3-Thread Wave Stitch & Chain C-1 needle position

3-Thread Wave Stitch & Right Narrow Cover Stitch

3-Thread Wave Stitch & Left Narrow Cover Stitch

3-Thread Wave Stitch & Wide Cover Stitch

3-Thread Wave Stitch & Triple Cover Stitch

3-Thread Reversed Wave Stitch & Chain C-3 needle position

3-Thread Reversed Wave Stitch & Chain C-2 needle position

3-Thread Reversed Wave Stitch & Chain C-1 needle position

3-Thread Reversed Wave Stitch & Right Narrow Cover Stitch

3-Thread Reversed Wave Stitch & Left Narrow Cover Stitch

3-Thread Reversed Wave Stitch & Wide Cover Stitch

3-Thread Reversed Wave Stitch & Triple Cover Stitch

## Expressive Stitches (Cont.)

3-Thread Overlock Wide & Chain C-3 needle position  
3-Thread Overlock Wide & Chain C-2 needle position  
3-Thread Overlock Wide & Chain C-1 needle position  
3-Thread Overlock Wide & Right Narrow Cover Stitch  
3-Thread Overlock Wide & Left Narrow Cover Stitch  
3-Thread Overlock Wide & Wide Cover Stitch  
3-Thread Overlock Wide & Triple Cover Stitch

3-Thread Flatlock Narrow & Chain C-3 needle position  
3-Thread Flatlock Narrow & Chain C-2 needle position  
3-Thread Flatlock Narrow & Chain C-1 needle position  
3-Thread Flatlock Narrow & Right Narrow Cover Stitch  
3-Thread Flatlock Narrow & Left Narrow Cover Stitch  
3-Thread Flatlock Narrow & Wide Cover Stitch  
3-Thread Flatlock Narrow & Triple Cover Stitch

3-Thread Rolled Hem & Chain C-3 needle position  
3-Thread Rolled Hem & Chain C-2 needle position  
3-Thread Rolled Hem & Chain C-1 needle position  
3-Thread Rolled Hem & Right Narrow Cover Stitch  
3-Thread Rolled Hem & Left Narrow Cover Stitch  
3-Thread Rolled Hem & Wide Cover Stitch  
3-Thread Rolled Hem & Triple Cover Stitch

3-Thread Rolled Wave & Chain C-3 needle position  
3-Thread Rolled Wave & Chain C-2 needle position  
3-Thread Rolled Wave & Chain C-1 needle position  
3-Thread Rolled Wave & Right Narrow Cover Stitch  
3-Thread Rolled Wave & Left Narrow Cover Stitch  
3-Thread Rolled Wave & Wide Cover Stitch  
3-Thread Rolled Wave & Triple Cover Stitch

2-Thread Overlock Narrow & Chain C-3 needle position  
2-Thread Overlock Narrow & Chain C-2 needle position  
2-Thread Overlock Narrow & Chain C-1 needle position  
2-Thread Overlock Narrow & Right Narrow Cover Stitch  
2-Thread Overlock Narrow & Left Narrow Cover Stitch  
2-Thread Overlock Narrow & Wide Cover Stitch  
2-Thread Overlock Narrow & Triple Cover Stitch

2-Thread Overlock Wide & Chain C-3 needle position  
2-Thread Overlock Wide & Chain C-2 needle position  
2-Thread Overlock Wide & Chain C-1 needle position  
2-Thread Overlock Wide & Right Narrow Cover Stitch  
2-Thread Overlock Wide & Left Narrow Cover Stitch  
2-Thread Overlock Wide & Wide Cover Stitch  
2-Thread Overlock Wide & Triple Cover Stitch

## Turning Corners - Chain Stitch

Sew to the point in fabric where you want to turn a corner. Stop the machine. Turn the handwheel toward you (counterclockwise) by hand, making sure the needle is going down in the fabric. Slowly start to raise the needle OUT OF FABRIC. Stop when you see the eye of the needle. (The point of the needle will still be in the fabric) Raise the presser foot, and slowly pivot the fabric. (fig. B) Lower the presser foot and continue to sew. (fig. C)

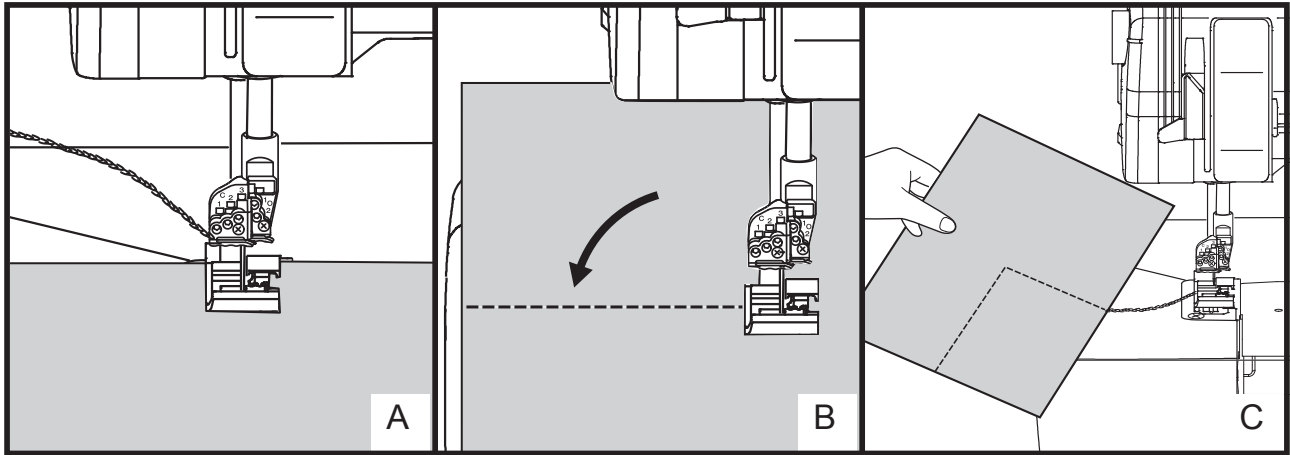

## Turning Corners - Cover Stitch

Sew to the point in fabric where you want to turn a corner. Stop the machine. Turn the handwheel toward you (counterclockwise) until the needles are down in the fabric. Turn the handwheel away from you (clockwise) until the needles are in the highest position and the needles are out of the fabric. Raise the presser foot and slowly pivot the fabric. Align the needles with the stitching on the fabric (fig. B) and lower the presser foot. Continue to sew. (fig. C)

To keep the stitch from unraveling at the corner(s), use a hand needle and thread to complete the corner on the top of the fabric and catch the chain looper thread on the underside.

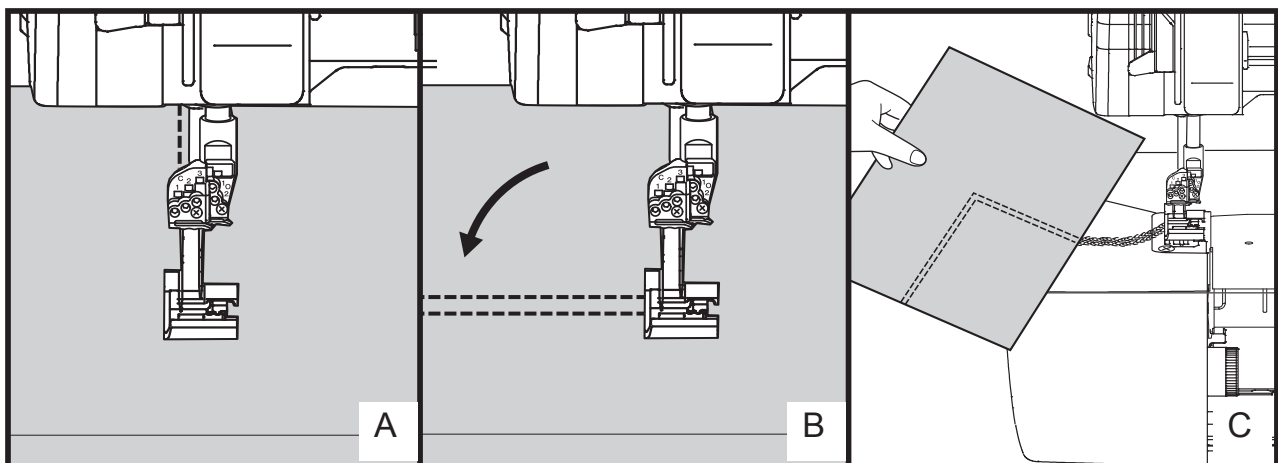

## Turning Outside Corner - Overlock

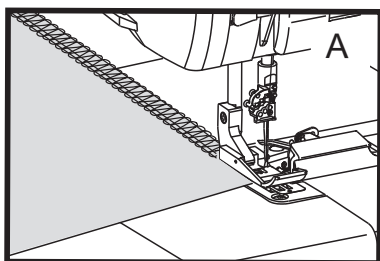

1. Stitch along one edge until you reach the corner. Take one stitch off the edge of the fabric. (fig. A) (As you approach the edge, you may want to stop and manually turn the handwheel towards you)

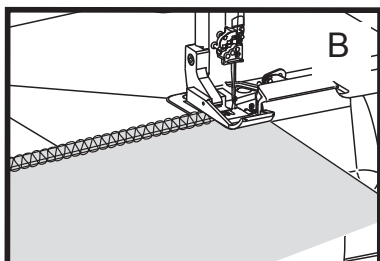

2. Raise the needle(s) to the highest position.  
3. Clear the stitch fingers, and rotate the fabric to reposition the needle at the previous row of stitching. (fig. B) Gently pull up on all threads to remove slack and resume stitching. (fig. C)

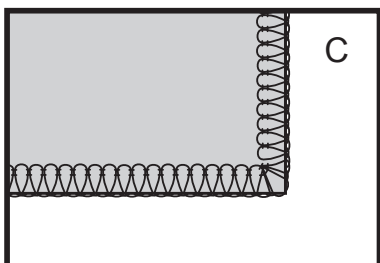

**Note:** A loose thread loop at the corner is caused by too much slack in the needle thread when clearing the stitch fingers. Try again, turning corners requires a little practice!

## Turning Inside Corner - Overlock

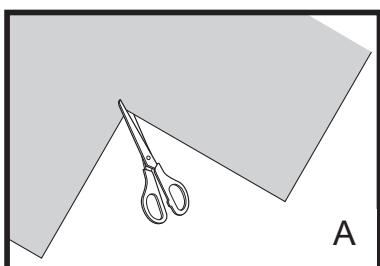

1. Reinforce loosely woven fabrics at the corner with staystitching on the conventional sewing machine. Clip to the corner. (fig. A)

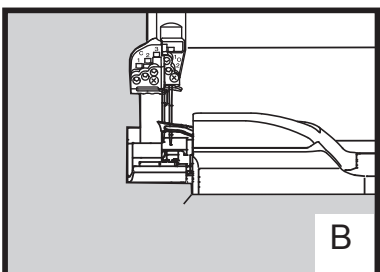

2. Align the fabric edge with the blade, and stitch until the blade reaches the corner, not the needles. Don't cut into the corner. (fig. B)

3. Lower the needle(s) to anchor the fabric.

4. Raise the presser foot and straighten out the fabric, forming a pleat at the corner. (fig. C)

5. Be sure the marked stitching line is straight, then continue serging the remaining edge. When done correctly, the pleat will disappear after stitching. (fig. D)

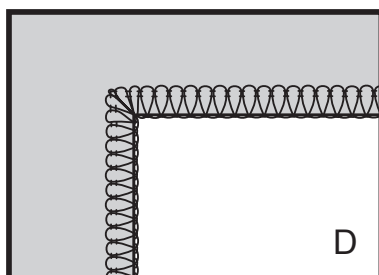
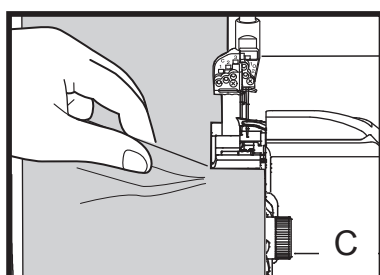

## Flat Hemming - Cover Stitch

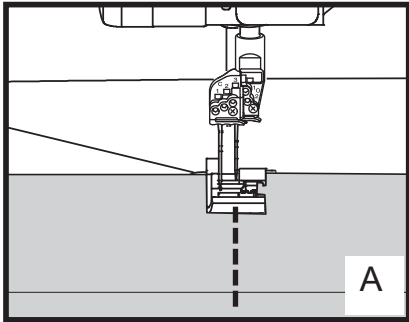

1. Leave one seam on the garment open.
2. Measure, turn up and press hem on garment.
3. On right side of garment mark hem allowance with marking pen.
4. Place garment right side up under the presser foot, aligning the marked hem with the needles. Make sure both needles are positioned on the raw edge of the hem. (fig A)
5. Sew hem.
6. Sew seam on garment.

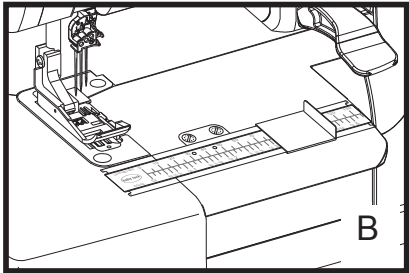

**Note:** Optional guide or attachments will help with hemming. (fig.B) Ask your Baby Lock retailer.

## Hemming in the Round - Cover Stitch

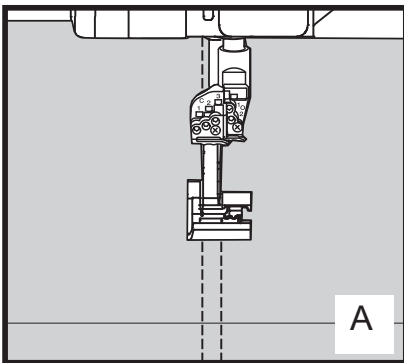

1. Sew all seams on the garment.
2. Measure, turn up and press the hem on garment.
3. Stitch around the hem, overlapping the hem approximately 1/2 inch (13mm). (fig.A)
4. Turn the handwheel towards you until the needles are in the lowest position in the fabric.
5. Carefully reverse the handwheel until the needles are in the highest position.
6. Raise the presser foot to release the tension.
7. Carefully and firmly pull fabric and threads to the left. Cut threads.
8. Pull threads to the back of fabric and tie off. (fig.B)
9. Use a seam sealant to secure the threads at the tie off.

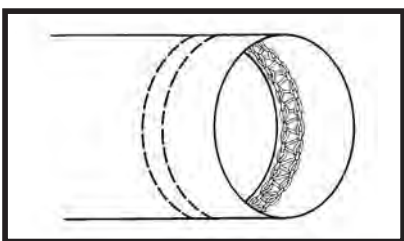
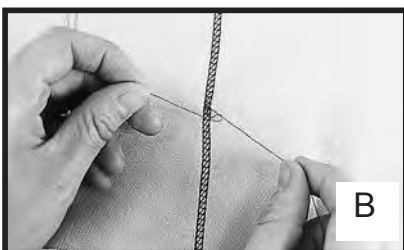

# Blind Hemming - Overlock

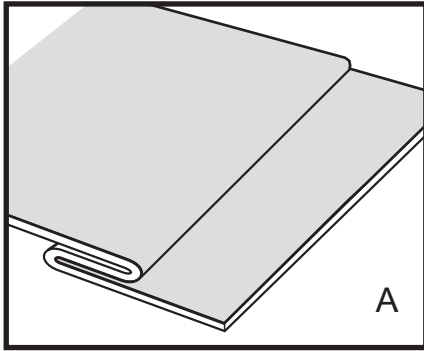

Your Baby Lock Ovation can create a sturdy, nearly invisible blindhem.

1. Set the machine for 2-Thread Overlock with the O-2 needle threaded. Set the stitch width at 5.0 and the stitch length at 4.0 in the standard range.
2. Fold up the hemline and press it in place. Then fold the hem allowance back against the fabric's right side to create a fold about 1/4 " from the top edge of the hem as shown. (fig. A)
3. Align the fold under the presser foot and stitch, allowing the needle to catch only a thread or two of the soft fold; the blade will trim the top edge of the hem and the loopers will overcast the edge for a clean finish. (fig. B)
4. Open the fold and press flat. (fig. C)

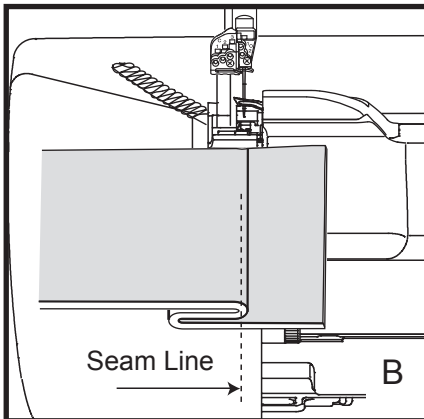

**Note:** An optional blindhem foot for consistent guiding is available through your Baby Lock retailer. (fig. D)

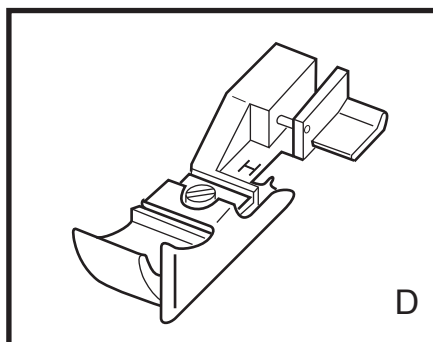
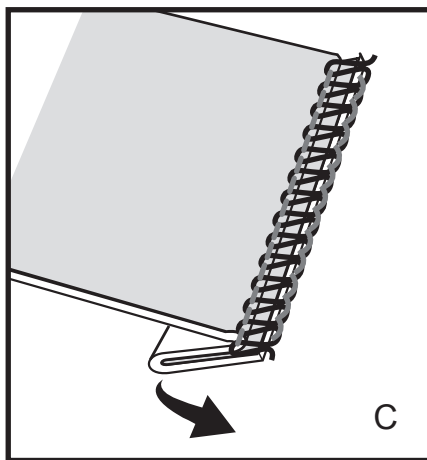

## Tape slots

The presser foot which comes with your Ovation has 3 types of slots. This enables you to use assorted sized tapes with various serging applications.

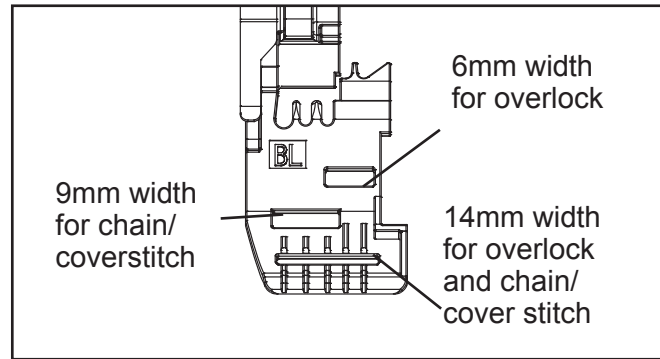

## Inserting Tapes - Overlock

The slot in the standard presser foot is designed to guide stabilizing tape, narrow elastic or decorative ribbon into the stitching. Insert tape or elastic into the slot and under the back of the foot. (fig. A) Adjust the stitch width to match the tape width. Place the fabric under the foot and stitch. (fig. B)

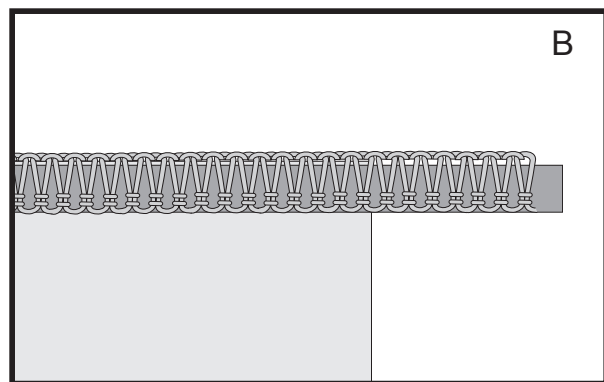
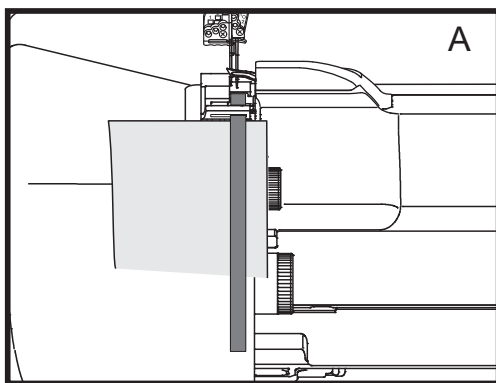

## Inserting Tapes - Cover Stitch

The slot on the standard foot can be used with the narrow, wide, or triple cover stitches. Decorative tape, ribbon, or elastic can be inserted into the slot and sewn with the cover stitch. (fig. A)

Insert the tape, ribbon or elastic into the slot and down under the foot to the needles. (Remember, that the cover stitch must be started in the fabric)

When using the sewing table, the decorative tape, ribbon, or elastic can be placed anywhere on the fabric. (fig. B)

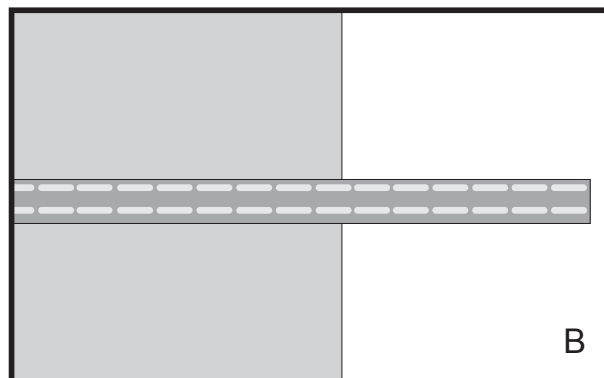
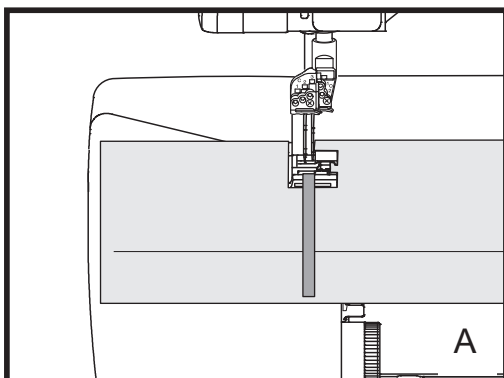

# Flatlock "Decorative" - Overlock

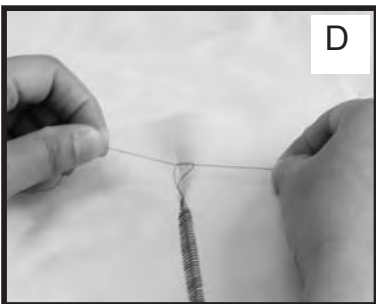
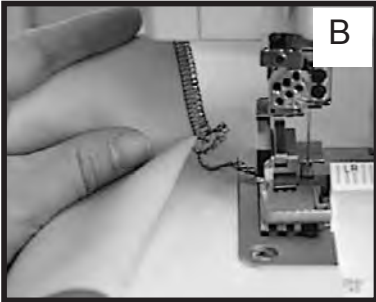
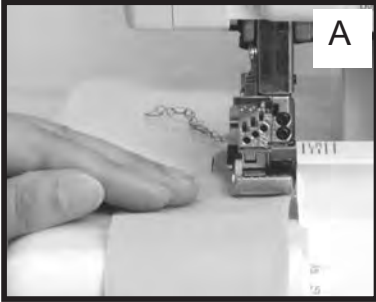

The flatlock stitch need not be limited at seamlines.

When sewn on a fold, flatlocking can create attractive decorative effects within the body of a garment or project. Either follow placement lines on your pattern or design your own special effects by stitching the fabric before laying out pattern pieces.

1. Set the machine for 2-thread flatlock - wide. (see page 36)
2. Turn the cutting blade locking dial clockwise to disengage the upper blade.
3. Set the stitch length to desired setting.
4. Fold the fabric (right side or wrong side out, depending on the loop or ladder stitch you want to show) along stitch placement lines.
5. Position the fabric under the presser foot, aligning the fold of the fabric 1/8 inch (3.5mm) to the left of the upper blade. (fig A) (see note)
6. Stitch to the desired ending point.
7. Clear the stitch fingers and chain off the fabric. (fig B)
8. Clip threads, leaving a 3-4 inch (7.5-10cm) chain.
9. Gently pull the fabric to flatten the stitches. (fig C)
10. Separate the chain threads and thread them through a hand needle and pull them to the fabric back side. If necessary, tie a knot to secure the threads. (fig D)

**Note:** If the fabric does not pull completely flat under the stitches, guide the fabric fold to the left so that the loops hang slightly off the fold as they are being stitched.

## Securing Ends - Overlock

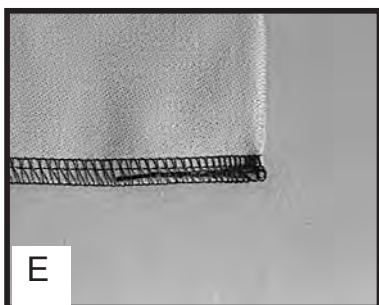
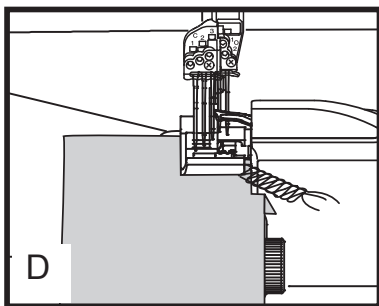
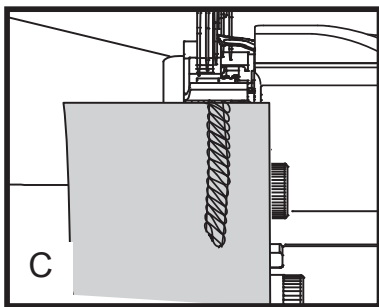
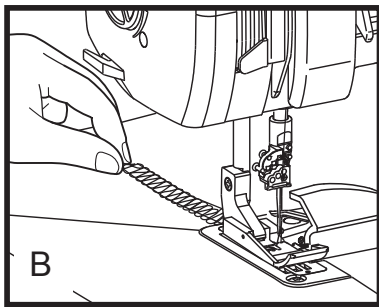
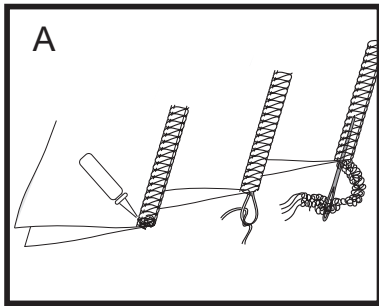

The serger stitch will not unravel readily, and in most cases serged seams are secured by an intersecting seam. If that's not the case, these are several options for securing seams. (fig. A)

1. Leave a 3 inch (7.5cm) chain, separate the threads and tie a knot.
2. Apply a dot of seam sealant on the thread chain at the fabric edge. Allow to dry and cut off the excess thread chain.
3. Leave a 3-4 inch (7.5-10cm) thread chain and use a large-eye tapestry needle or double-eye needle to weave the chain back into the stitching.
4. Lock the beginning or end of a seam by serging over the previous stitches.

### To lock the beginning of the seam:

1. Manually turn the handwheel toward you taking 2-3 stitches into the fabric. Leave the needle(s) in the lowest position to anchor the fabric.
2. Raise the presser foot.
3. Smooth out the thread chain with your fingers. (fig. B) Then bring the chain around and under the foot, so that it aligns with the edge of the fabric. (fig. C)
4. Lower the foot and continue sewing, catching the thread chain in the stitches for about 1 inch (2.5cm). Let the blades cut off any remaining thread chain. (fig. D-E)

## Securing Ends - Overlock (Cont.)

### To lock the end of the seam:

1. Take one stitch off the end of the seam. (fig. F)
2. Raise the presser foot and bring the needle(s) to the highest position. Pull back gently on the fabric to clear the stitch fingers.
3. Carefully turn the fabric over, end to end (fig. G), and reposition it under the presser foot with the needle at the seam edge, aligned with the previous needle line. (fig. H)
4. Lower presser foot and sew 5-6 stitches over the previous stitches, being careful not to cut them. You may want to turn the cutting blade locking dial clockwise to the "LOCK" position. Pivot the fabric and chain off. (fig. I - J)

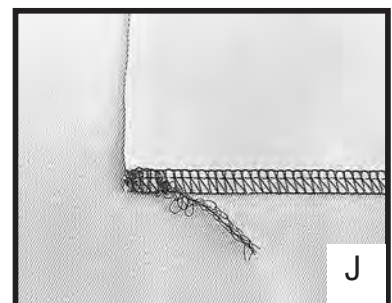
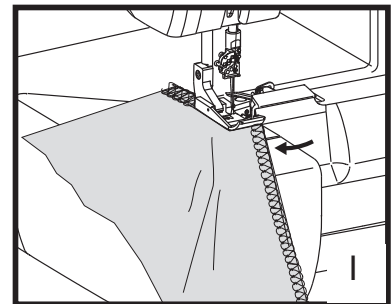
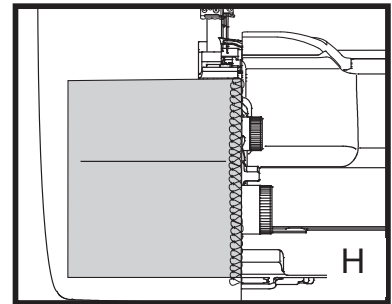
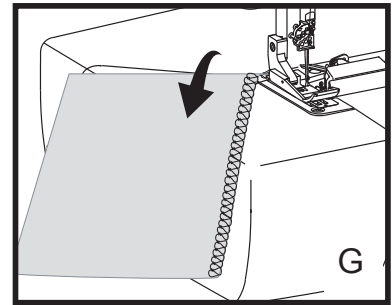
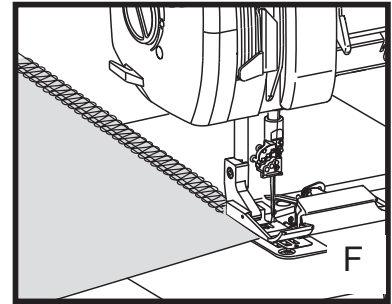

## Securing Chain and Cover Stitching

The Chain Stitch and Cover Stitch can easily be removed. Trim the chain tail to edge of fabric at the "end" of the seam and pull on the chain looper thread on underside of the fabric. This will give you the opportunity to "Unsew" an incorrect seam very easily.

To secure the chain stitch or cover stitch, at the end of the seam, bring the needle thread(s) to the back of the fabric and tug on the needle threads to secure them. The cover stitch needle threads may also be tied to prevent raveling of the stitch. Seam sealant can also be applied to the thread ends.

Because the chain stitch can be easily removed, the stitch can have a multitude of sewing functions.

- For dressmakers it can be used as a fitting seam. It can easily be removed to let out the seam quickly.
- tucks in children's clothing.
- in wide elastic in waistbands.

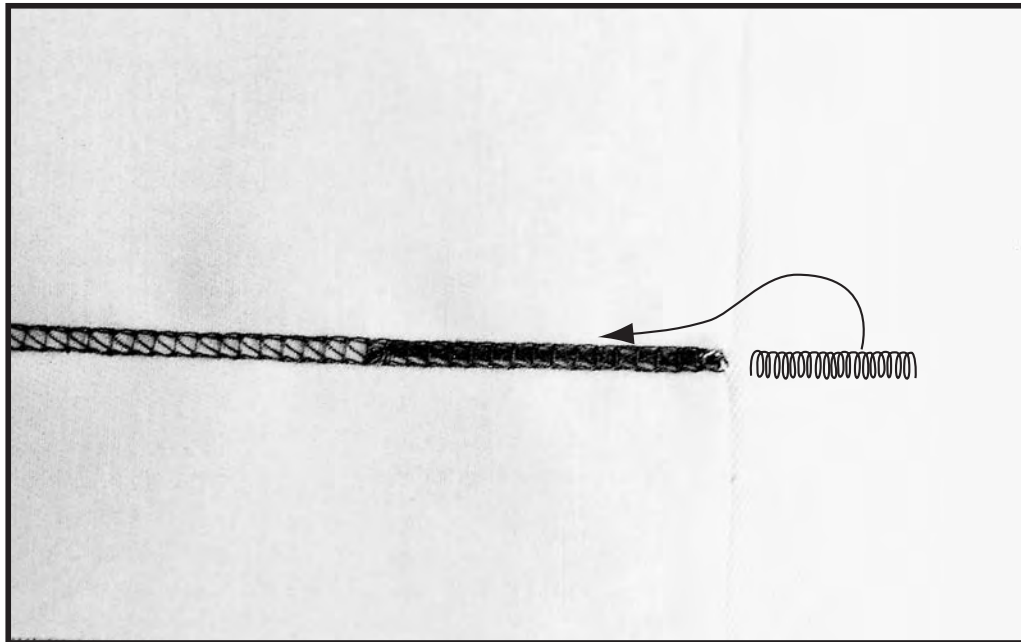

Notes:

## Using Specialty Threads

Beautiful stitches can be formed by serging with specialty threads, cords, and ribbons. These heavy or shiny threads can be used to enhance the appearance of a stitch, add strength and elasticity, or create special effects. It depends on the thread you choose for the chosen technique.

Some specialty threads work well through the needle and loopers, while others are too heavy to be threaded through the needle and are for looper use only.

Use the "Specialty Thread Guide Chart" on pages 80 and 81 as a guide for the specialty threads. Keep in mind that the quality of the thread may vary from one manufacturer to another. Make test samples before starting on the project.

## Lightweight Threads

**Lightweight threads** such as rayon machine embroidery thread or lingerie thread, can easily be threaded on the Ovation. Very fine monofilament threads may require threading assistance using a "Threading Cradle" (page 79) or "Looper Threading Tool" (page 78).

## Medium Weight Threads

**Medium weight threads**, such as topstitching thread, Décor rayon and stretch nylon thread are too bulky to easily "jet-air" through the threading port and loopers. By using a "Threading Cradle" or "Looper Threading Tool", the heavier threads can be threaded easily in the Ovation.

## Heavy Weight Threads

**Heavy weight threads** such as Pearl Crown Rayon, Décor 6, and Candlelight will need extra attention in the upper, lower, and chain loopers. Please follow the Specialty Thread Guide Chart on page 80 for special instructions concerning the use of these threads.

# Bypassing the Threading Port

Heavy weight threads can be used through your regular looper thread paths. Specific techniques may require that the thread bypass the thread port for the thread pull to be loosened. Start with the machine threaded with regular serger thread.

1. Open the front and the cutting blade covers and raise the presser foot.
2. Just above the threading port, clip the looper thread to be replaced. Pull the thread out of the upper guides and remove the cone.
3. Place the specialty thread on the spool pin. Thread it into the upper guides and clip it a couple of inches beyond the base plate. (fig. A)
4. Thread the specialty thread into the Bypassing thread guide located on the left side of the threading ports. (fig. B)
5. With machine in the serging position, use the tweezers to pull the existing looper thread out of tube extending from the threading mechanism. (fig. C) Leave the thread in the looper arm.
6. Tie the specialty thread onto the regular thread with an overhand knot. (fig. D) Pull on the regular thread from the looper eye until the specialty thread comes through the looper eye. (fig. E)
7. Place upper looper thread under the foot and to the left: clip lower looper thread at the base plate.

If the thread is heavy and the overhand knot (step #6) is too large for the looper tube, follow Steps 1 through 7 on page 79 to make a thread cradle. Then:

1. Engage the threading lever to the serging position.
2. While holding the loose ends of the thread cradle with one hand, use the tweezers to pull the cradle loop out of the tube extending from the threading mechanism with the other hand.
3. Insert 2 inches (5cm) of your decorative thread into the cradle loop. Pull on the loose ends of the thread cradle from the looper eye until the specialty thread comes through the looper eye.

When bypassing the threading port, thread will be visible from the guide to the looper tube. (fig. F) Close the cutting blade cover and front cover before continuing to sew.

**Note:** When necessary to use Bypassing thread guides with thread cradle make sure threads are not twisted and / or tangled leading from the guides.

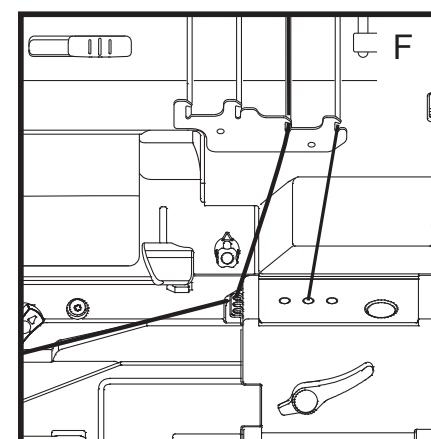
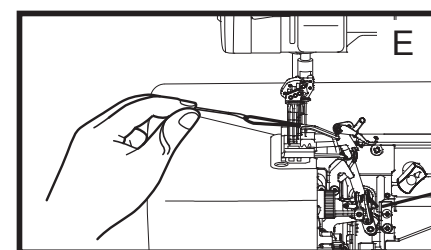
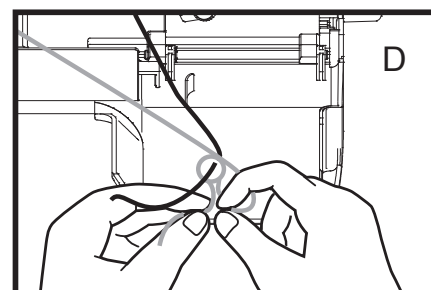
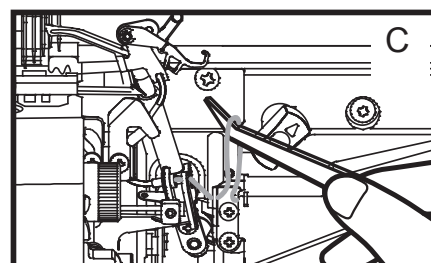
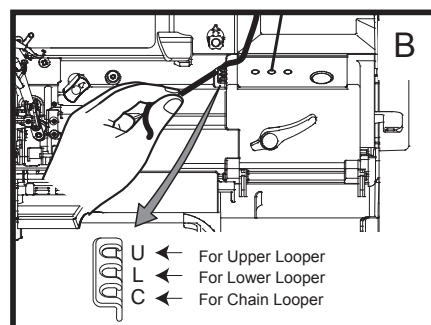
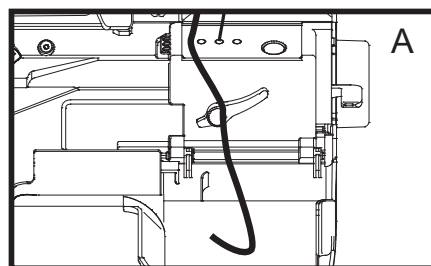

# Looper Threading Tool

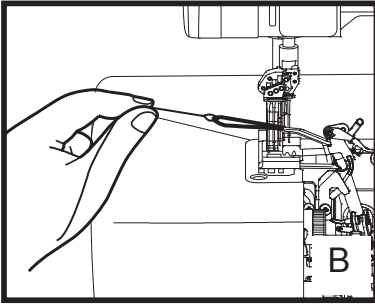
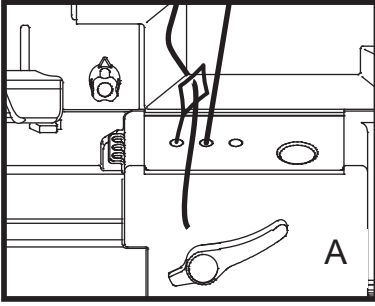

1. Open the front cover and raise the presser foot.
2. At the threading port, cut the looper thread that is to be replaced. Remove thread from under the foot and the upper thread guides. Replace cone of thread with specialty thread.
3. Engage the threading lever to the threading position.
4. Thread specialty thread into the upper thread guides, leaving an 18 inch (40cm) tail above the threading port.
5. Place the straight end of the looper threading tool into the threading port. Push the looper threading tool until the end comes out of the looper eye. For the chain looper, open side door of machine to see threading tool come out of the eye of chain looper.
6. Insert the specialty thread tail into the looper threading tool eye. (fig.A) Pull the straight end of the looper threading tool through the looper eye bringing the specialty thread with it. (fig.B)
7. Place upper looper thread under the foot and to the left, cut lower looper thread to 4 inches (10cm) and leave it hanging loose. Cut chain looper thread 4 inches (10cm) and place in tray. Close the side door, cutting blade cover and front cover of machine.

**Note:** Make sure the looper tubes are clear of thread(s) before re-threading machine.

# Thread Cradle for Loopers

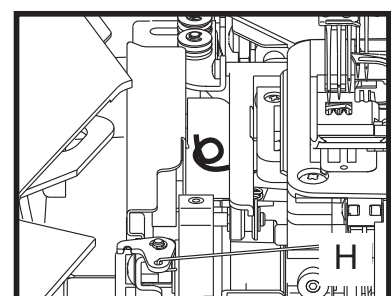
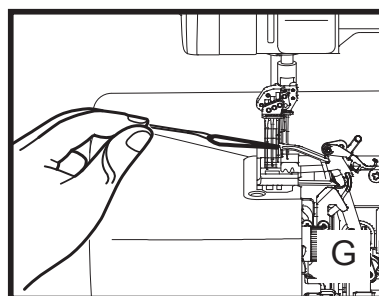
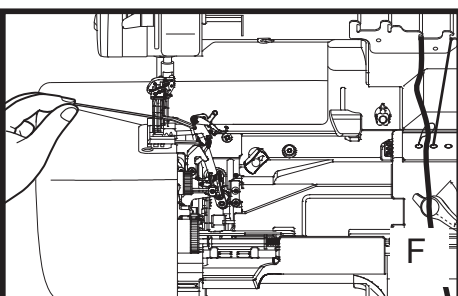
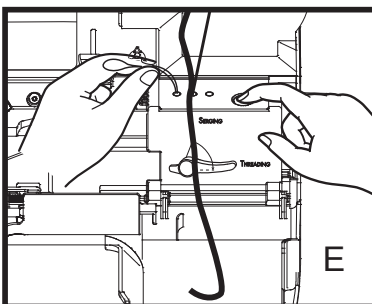
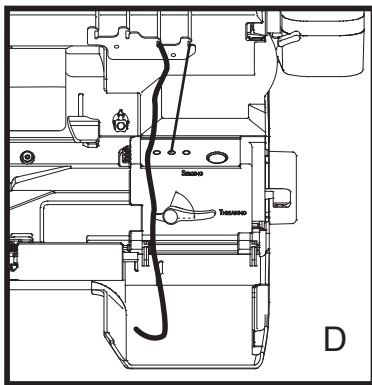
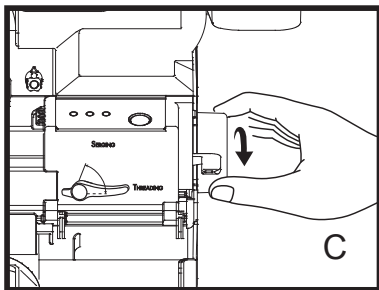
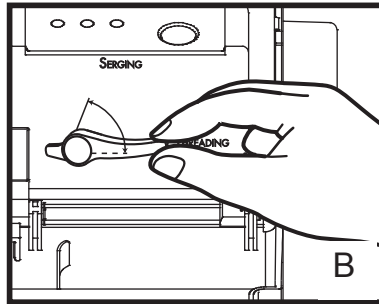
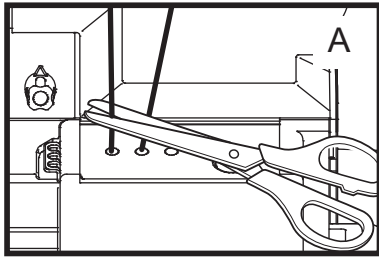

1. Open the front cover and cutting blade cover then raise the presser foot.
2. At the threading port, clip the looper thread that is to be replaced. (fig.A) Remove thread from under the presser foot and the upper thread guides. Replace cone of thread with specialty thread.
3. With the threading lever engaged in the threading position (fig. B) turn handwheel toward you to close looper tubes. (fig. C)
4. Thread specialty thread into the upper thread guides, leaving an 18 inch (40cm) tail above the threading port. (fig.D)
5. Cut a 24 inch (55cm) strand of serger thread and fold in half to form a thread cradle. Insert the loose ends of the thread cradle into the port about 1 inch (2.5cm).
6. Holding the cradle loop with left hand, push the threading button with your right hand (fig.E) until the thread ends come out the looper eye. For chain looper, open side door of machine to make sure thread is laying inside the tray.
7. Insert the specialty thread tail into the cradle loop (fig.F), pull the serger thread ends until the specialty thread comes through the looper eye. (fig.G) Discard or set aside the thread cradle.
8. Place upper looper thread under the foot and to the left, cut lower looper thread to 4 inches (10cm) and leave it hanging loose. Cut chain looper thread 4 inches (10cm) and place in tray.(fig. H)

Close side door, cutting blade cover and front cover of machine.

## Specialty Thread Guide Chart

| <b>OVERLOCK STITCHES</b>   | <b>Topstitching<br/>Buttonhole Twist<br/>(Medium weight)</b> | <b>Wooly Nylon<br/>(Medium weight)</b>                 | <b>Metallic Threads<br/>(Lightweight)</b>                      |
|--|--|--|--|
| <b>APPLICATION</b>   | Decorative Edging<br>Decorative Flatlocking                  | Rolled Hem<br>Soft seams on Lingerie<br>and sportswear | Decorative Edging<br>Decorative Topstitching                   |
| <b>4-Thread Seams</b>  | Not recommended  | Use in loopers only                                    | For decorative exposed<br>seams. Use in needles<br>and loopers |
| <b>4-Thread Edging</b>   | Use in loopers only  | Use in loopers only                                    | Use in needles and<br>loopers                                  |
| <b>3-Thread Seams</b>  | Not recommended  | Use in loopers only                                    | For decorative exposed<br>seams. Use in needles<br>and loopers |
| <b>3-Thread Edging</b>   | Use in loopers only  | Use in loopers only                                    | Use in needle and<br>loopers                                   |
| <b>3-Thread Rolled<br/>Edging</b>                                      | Use in upper looper only                                     | Use in upper looper only                               | Use in upper looper only.<br>Lengthen stitch length.           |
| <b>3-Thread<br/>Wave</b>   | In upper or lower looper.<br>Or both loopers                 | In upper or lower looper.<br>Or both loopers           | In upper or lower looper.<br>Or both loopers                   |
| <b>3-Thread<br/>Rolled Wave</b>  | Use in upper looper<br>only                                  | In upper or lower looper.<br>Or both loopers           | In upper or lower looper.<br>Or both loopers                   |
| <b>2-Thread Flatlock<br/>(wide or narrow)</b>                          | Not recommended  | Use in lower looper only                               | Use in lower looper only                                       |
| <b>COMMENTS:</b>   | Sew at a slower speed<br>when sewing with<br>heavier threads |  | Sew at a slower speed<br>when sewing with<br>metallic threads  |
| <b>CHAIN/COVER<br/>STITCHES</b>  | <b>Topstitching<br/>Buttonhole Twist<br/>(Medium weight)</b> | <b>Wooly Nylon<br/>(Medium weight)</b>                 | <b>Metallic Threads<br/>(Lightweight)</b>                      |
| <b>2-Thread Chain<br/>C-1, C-2, or C-3<br/>Needle Position</b>         | In chain looper only   | In chain looper only                                   | In chain needle only   |
| <b>3-Thread Cover Stitch<br/>Left Narrow<br/>Right Narrow<br/>Wide</b> | In chain looper only   | In chain looper only                                   | In needles only  |
| <b>4-Thread Triple Cover<br/>Stitch</b>                                | In chain looper only   | In chain looper only                                   | In needles only  |
| <b>5-Thread Safety Stitch</b>  | Not recommended  | In loopers only  | Not recommended  |
| <b>6-Thread Stitch<br/>7-Thread Stitch<br/>8-Thread Stitch</b>         | In loopers only  | In loopers only  | Not recommended  |
| <b>COMMENTS:</b>   | Not recommended for<br>needles. Use in<br>looper(s) only.    | Not recommended for<br>needles                         | Sew at a slower speed<br>when sewing with<br>metallic threads. |

## Specialty Thread Guide Chart (Cont.)

|  |   |   |  |
|--|---|---|--|
| <b>OVERLOCK STITCHES</b>                                   | <b>Clear Nylon (Lightweight) ※1</b>   | <b>Lingerie Thread, Rayon or Polyester Machine-embroidery Thread (Lightweight) ※2</b>   | <b>Decorative Thread: Décor, Candlelight, Pearl Crown Rayon (Heavy weight) ※3</b>  |
| <b>APPLICATION</b>   | Techniques requiring thread invisibility.   | Lingerie and light-weight fabrics, edging of fine fabric, fine rolled hem   | Decorative edging<br>Decorative flatlocking<br>Decorative rolled hem<br>Decorative chain/coverstitching                      |
| <b>4-Thread Seams</b>                                      | Not recommended   | Lingerie thread for seams. Machine embroidery thread for exposed decorative seams   | Not recommended  |
| <b>4-Thread Edging</b>                                     | Not recommended   | Machine Embroidery Thread only  | Use in looper(s) only  |
| <b>3-Thread Seams</b>                                      | Recommended for blind hemming   | Lingerie thread only  | Not recommended  |
| <b>3-Thread Edging</b>                                     | Not recommended   | Machine Embroidery Thread only  | Use in looper(s) only  |
| <b>3-Thread Rolled Edging</b>                              | Lengthen Stitch length slightly   | Use in needle and loopers   | Use in looper(s) only  |
| <b>3-Thread Wave</b>                                       | Not recommended   | Machine Embroidery Thread in upper and lower loopers  | Use in upper looper or lower looper. Not both loopers at once.   |
| <b>3-Thread Rolled Wave</b>                                | Not recommended   | Machine Embroidery Thread in upper looper   | Use in upper looper only   |
| <b>2-Thread Flatlock (wide or narrow)</b>                  | Recommended for blind hemming   | Use in needle and lower looper  | Use in lower looper only   |
| <b>COMMENTS:</b>   | Make sure to use soft, pliable monofilament thread. Sew at a slower speed when sewing with monofilament thread. | Use thread nets or sponge disks to keep thread from spilling off spool. Sew at a slower speed when sewing with decorative thread. | Candlelight thread: Bypass threading ports when threading loopers. Sew at a slower speed when sewing with decorative thread. |
| <b>CHAIN/COVER STITCHES</b>                                | Same as above※1   | Same as above※2   | Same as above※3  |
| <b>2-Thread Chain C-1, C-2, or C-3 Needle Position</b>     | Use in needle and chain looper  | Use in needle and chain looper  | Use in chain looper only   |
| <b>3-Thread Cover Stitch Left Narrow Right Narrow Wide</b> | Use in needles and chain looper   | Lingerie Thread: Use in needles and chain looper. Machine embroidery thread: Use in needles only.                                 | Use in chain looper only   |
| <b>4-Thread Triple Cover Stitch</b>                        | Use in needles and chain looper   | Lingerie Thread: Use in needles and chain looper. Machine embroidery thread: Use in needles only.                                 | Use in chain looper only   |
| <b>5-Thread Safety Stitch</b>                              | Not recommended   | Lingerie thread recommended only  | Use in chain looper and lower looper only for a reverse decorative stitch.   |
| <b>6-Thread Stitch 7-Thread Stitch 8-Thread Stitch</b>     | Not recommended   | Machine Embroidery Thread only  | Use in chain looper and lower looper only for a reverse decorative stitch.   |
| <b>COMMENTS:</b>   | Make sure to use soft, pliable monofilament thread. Sew at a slower speed when sewing with monofilament thread. | Use thread nets or sponge disks to keep thread from spilling off spool. Sew at a slower speed when sewing with decorative thread. | Not recommended for needles  |

# Troubleshooting

Before taking your machine in for service, check the following:

**Machine fails to start:**

1. Is the electrical plug and foot control jack properly connected?
2. Is the power switch on?
3. Check household circuit breaker or fuse.
4. Is the threading lever in the serging position?
5. Are the side, cutting blade and front covers closed securely?

**Thread breaks:**

1. Is the machine threaded correctly? Check each thread path carefully.
2. Is the correct needle inserted for the particular stitch? - C-1, C-2, C-3, O-1, or O-2?
3. Is the needle inserted correctly?
4. Is the needle bent or worn?
5. Are you using good quality thread?
6. Is the thread feeding off the cone/spool freely?
7. Is the needle size correct for the type of fabric being used?
8. Are the needles being used the correct Organ or Schmetz ELx705CF system?

**Chain or Cover Stitching:**

1. Are the tensions too tight on the chain/cover needles or the chain looper?
2. Is the stitch length too short?
3. Did you start the first stitch in the fabric?

**Overlock stitching:**

1. Is the stitch selector on the proper setting?
2. Is the upper looper positioning knob in the "UP" position?

**Skipped Stitches:**

1. Is the needle bent or worn?
2. Is the needle inserted correctly?
3. Is the serger threaded correctly?
4. Is the presser foot pressure right for the fabric?
5. Is the correct needle being used for the particular stitch?
6. Is the correct needle being used for the type of fabric being sewn?
7. Is the fabric being pulled from the rear of the machine while sewing?

**Fabric will not feed in machine:**

1. Is the machine engaged in the serging position?
2. Is the presser foot down?
3. Are the cutting blades sharp?
4. Are the cutting blades, presser foot, and feed dog free of lint?
5. Are the cutting blades properly set and is the upper blade against the lower blade?
6. Is the presser foot pressure right for the fabric?
7. Is the stitch length set properly?
8. Is the needle plate secure on the machine?

# Troubleshooting (Cont.)

**Stitch Unbalanced:**

1. Is the serger threaded correctly?
2. Is the proper presser foot on the serger?
3. Is the correct needle inserted and threaded?

**Chain or Cover Stitch unbalanced:**

1. Is the thread in the tensions?
2. Are the tensions set correctly for the chain/cover needles?
3. Is the tension dial set correctly for the chain looper?
4. Is the chain looper threaded correctly?
5. Is the needle thread(s) in the correct tension disk?

**Overlock Stitching unbalanced:**

1. Is the stitch selector on the proper setting?
2. Is the thread well seated in the thread slots?
3. Is the Upper & Lower looper thread fine-tuning knob positioned correctly?

**Note:** If you change the position of the Upper & Lower looper thread fine-tuning knob and the stitch is unbalanced, return the knob to the center position and recheck the stitch.

**Looper threading difficulties:**

1. Is the thread end in the proper threading port?
2. Is at least 1/2 inch (1.2cm) of the thread end in the threading port?
3. Is there at least 22 inches (56cm) of loose thread beyond the thread guide above the threading port?
4. Is the upper looper positioning knob set at "UP" position?
5. Is there a kink or twist in the 22 inch (56cm) of thread to restrict the flow into the threading port?
6. Is the thread caught to prevent going through the loopers?

**Poor Cutting:**

1. Are the cutting blade(s) dull?
2. Have you sewn over a straight pin?
3. Is the upper blade in the locked position?
4. Have the cutting blades been improperly replaced?
5. Is the fabric being pulled from the rear of the machine while sewing?

**Wave Stitch is not formed:**

1. Is the machine threaded correctly? Check each thread path carefully.
2. Is the machine set for 3-Thread Wave sewing?
3. Is the Wave/Overlock Selector Lever set on "WAVE"?
4. For rolled wave edging, is the stitch length dial set for "ROLLED HEM" ?
5. Is the Stitch Selector Lever set correctly? Set the Stitch Selector Lever at "B" for 3-Thread Wave Stitch or "C" for 3-Thread Rolled Wave Stitch.

# Replacing Needles

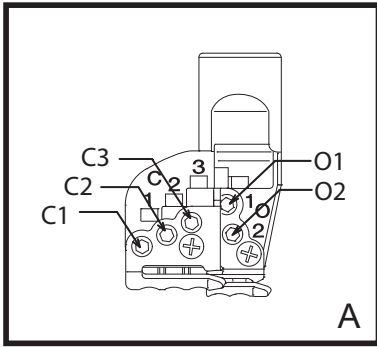

## Needle Identification (fig. A)-

The chain/cover stitch needle(s) are on the front left portion of the needle clamp and are identified by C-1,C-2 and C-3.

C-1-Left chain/cover stitch needle can be used for chain stitch, left narrow cover stitch, wide cover stitch or triple cover stitch.

C-2-Center chain/cover stitch needle can be used for a chain stitch, left narrow cover stitch, right narrow cover stitch or triple cover stitch.

C-3-Right chain/cover stitch needle can be used for a chain stitch, right narrow cover stitch, wide cover stitch, or triple cover stitch.

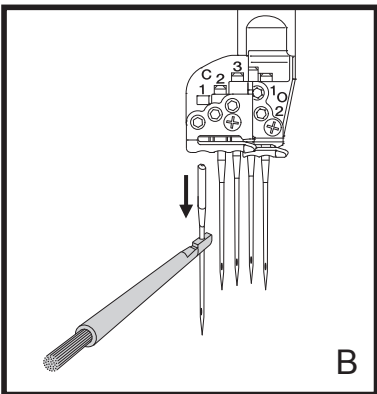

The overlock needles are on the back right portion of the needle clamp and are identified by O-1 and O-2.

O-1-Left overlock needle can be used for wide overlock stitches.

O-2-Right overlock needle can be used for narrow overlock stitches and rolled or narrow hemming.

**Note:** Both overlock needles are used for 4-thread overlock stitching.

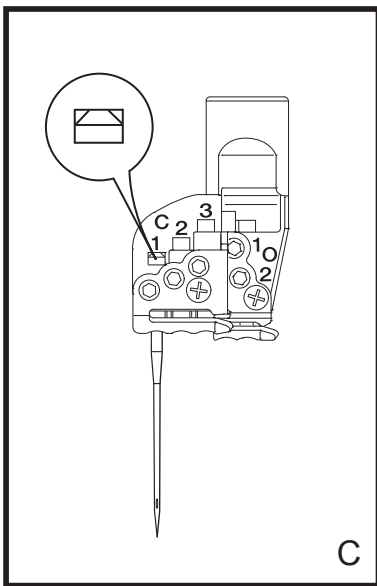

## To replace a needle -

1. Raise the needle(s) to the highest position by turning the handwheel toward you.
2. Using the allen screwdriver, loosen the needle screw for the needle to be changed. Screws are located by sequence as indicated above.

**Note:** To prevent the needle from falling into the needle plate, hold it with the needle insert tool as you loosen the screw. (fig. B)

3. Use the needle insert tool or tweezers to insert the new needle with the flat side to the back.

Insert needle as far as it will go, check the needle viewing window. (fig. C)

4. Tighten the needle clamp screw.

**Note:** If you do drop a needle down into the machine just pull out the needle-drop drawer at the bottom of your serger. The needle will be on the drawer. (fig. D)

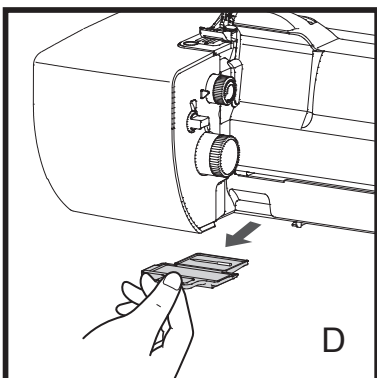

To reinsert the needle-drop drawer use right hand and align drawer with the left and right slots on bottom of machine and slide drawer in.

## CAUTION:

- Moving Parts- To reduce risk of injury, switch off before servicing.

CLOSE COVER BEFORE OPERATING MACHINE

## Replacing Cutting Blades

The fixed blade is made of a special long lasting steel and does not require frequent replacement. If necessary, contact your nearest retailer for replacement of the blade.

The upper cutting blade is made of a softer steel material and will require replacement. A spare blade is provided with the machine for replacement if necessary. The spare upper cutting blade is located in the accessory compartment & thread stand.

If for some reason your machine does not cut or perform as it should be, please take your machine to your nearest Baby Lock retailer. It is possible that the result of poor cutting may indicate other problems.

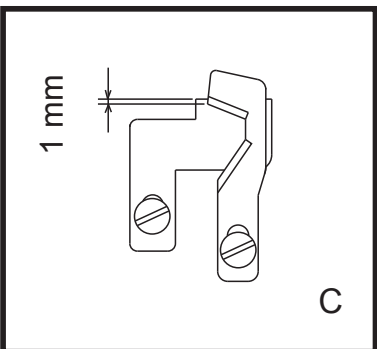
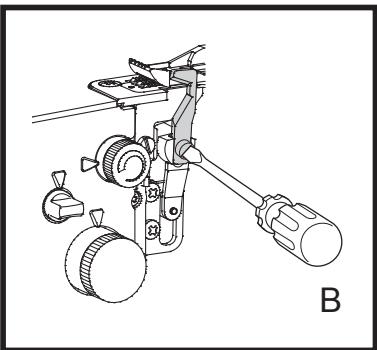
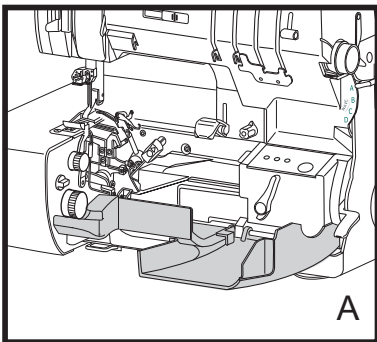

**TO REPLACE UPPER CUTTING BLADE** proceed as follow :

1. For safety reasons, unplug main power cord.
2. Open front cover and cutting blade cover. (fig. A)
3. Remove screw and upper blade. (fig. B)
4. Insert new upper blade into blade slot.
5. Insert screw and place upper blade to its highest position.
6. Hold upper blade in place and tighten screw.
7. Check and make sure that the upper section of cutting area of blade is set 1mm below the fixed blade when upper blade is in its lowest position. (fig.C)
8. Close cutting blade cover and front cover.

## Replacing LED Lighting

Your Baby Lock Ovation is equipped with a long-life LED lighting system, which is not necessary to change bulbs.

In case of replacing LED unit, please contact your authorized Baby Lock retailer.

# Cleaning

Your Baby Lock will operate at best performance if it is kept clean at all times. The serger's cutting action creates much more lint than you will find on conventional sewing machine.

Your serger's major moving parts are well protected and do not need to be oiled.

However, we recommend that you use the cleaning brush often during garment construction in order to keep lint off the blades, the needle bar, the feed dog mechanism and loopers. If machine needs to be oiled, check with your nearest Baby Lock retailer for use of high grade recommended sewing machine oil.

## TO REMOVE NEEDLE PLATE PROCEED AS FOLLOW:

1. For safety reasons, unplug main power cord.
2. Raise and remove presser foot.
3. Set stitch length dial to rolled hem setting.
4. Remove needles from needle clamp.
5. For easy access to the needle plate lock pin set screw, lower needle clamp to its lowest position. (fig. A)
6. Place allen screwdriver (1.5mm) into allen screw and loosen needle plate pin holder screw. (fig. B for location of screw)
7. Remove needle plate lock pin (fig B) and remove needle plate front screw. (left arrow in fig B)
8. Open left side cover of machine and remove needle plate.
9. Clean machine. (fig. C)
10. Place needle plate onto machine and insert needle plate lock pin.
11. Tighten allen screw needle plate lock pin and check and make sure that top needle plate lock pin is flush with needle plate.
12. Place needle plate front screw and tighten screw.

**Note:** For better stitch performance, make sure needle C-1, C-2 and C-3 do not touch either side of needle plate hole.

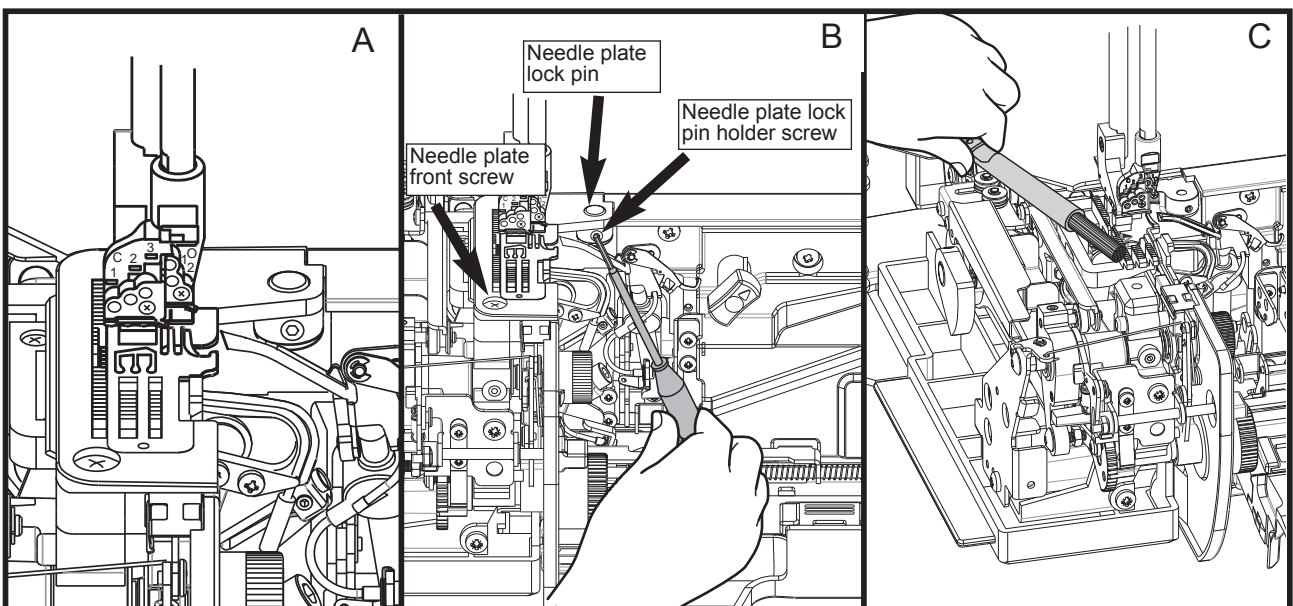

# Technical Data

## Stitch Types:

Chain Stitch  
- Left (C-1), Center (C-2), Right (C-3)

Cover Stitch  
- Narrow Left  
- Narrow Right  
- Wide  
- Triple

Overlock Stitch  
- 4-Thread Overlock (narrow and wide)  
- 3-Thread Overlock (narrow and wide)  
- 3-Thread Flatlock  
- 3-Thread Rolled Hem  
- 3-Thread Wave  
- 3-Thread Rolled Wave  
- 3-Thread Reversed Wave  
- 2-Thread Overlock (narrow and wide)  
- 2-Thread Flatlock (narrow and wide)

Combined Stitch  
- 5-Thread Safety Stitch  
- 6-Thread Stitch  
- 7-Thread Stitch  
- 8-Thread Stitch

## Stitch Width:

Cover Stitch  
- Triple Cover Stitch: 6.0mm  
- Cover Stitch - Wide: 6.0mm  
- Cover Stitch - Narrow: 3.0mm

Overlock Stitch  
- Standard 2/3/4-Thread Overlock with left needle: 5.5-7.5mm  
- Standard 2/3/4-Thread Overlock with right needle: 3.0-5.0mm  
- 3-Thread Rolled Hem with right needle : 1.5mm

Combined Stitch  
- 5-Thread Safety Stitch: 6.5-16.0mm  
- 6-Thread Ultra Stitch: 9.5-16.0mm  
- 7-Thread Ultra Stitch: 12.5-16.0mm  
- 8-Thread Ultra Stitch: 14.0-16.0mm

## Stitch Length:

0.75 - 4.0mm

## Differential Feed:

Gathering effect: N ~ 2

Stretching effect: N ~ 0.6

## Presser Foot:

Snap on exclusive feet for Ovation

## Handwheel:

Rotate backward (toward you; counterclockwise)

## Loopers:

3 Loopers: Upper(U), Lower(L), Chain(C)

## Needle System:

Organ or Schmetz ELx705CF #80/12 - #90/14

## Number of Needles:

5 total: 3 Chain/Cover Stitch, 2 Overlock

## Sewing Speed:

Up to 1500 s.p.m.

## Machine Weight:

12.4kgs/28lbs.

## Light System:

6 LED Lights

## Chart for Stitch Selection Settings for Chain/Cover and Combination Stitches

| Stitch Name              | Nb. Needles & ndle position | Looper(s) U - L - C | Stitch L/dial | Stitch W/dial | Stitch Selector | Wave Selector | Ch. looper tension dial | Ch/Cov needle tension dial | Diff. Feed | Finish seam Width |
|--------------------------|-----------------------------|---------------------|---------------|---------------|-----------------|---------------|-------------------------|----------------------------|------------|-------------------|
| <b>8 Thread</b>          |                             |                     |               |               |                 |               |                         |                            |            |                   |
| Triple Cover stitch with | C1 - C2 - C3                | U - L - C           | 2.5 - 4.0     | 7.5           | A               | OVERLOCK      | Cover Stitch            | 5.0 *                      | N          | 16 mm             |
| 4 thread overlock        | O1 - O2                     |                     |               |               |                 |               |                         |                            |            |                   |
| <b>7 Thread</b>          |                             |                     |               |               |                 |               |                         |                            |            |                   |
| Triple Cover stitch with | C1-C2-C3-O1 (Wide)          | U - L - C           | 2.5 - 4.0     | 7.5           | A               | OVERLOCK      | Cover Stitch            | 5.0 *                      | N          | 16 mm             |
| 3 thread overlock        | C1-C2-C3-O2 (Narrow)        | U - L - C           | 2.5 - 4.0     | 5.0           | B               | OVERLOCK      | Cover Stitch            | 5.0 *                      | N          | 16 mm             |
| Cover Stitch with        | C1-C2-O1-O2                 | U - L - C           | 2.5 - 4.0     | 7.5           | A               | OVERLOCK      | Cover Stitch            | 5.0 *                      | N          | 16 mm             |
| 4 thread overlock        | C1-C3-O1-O2                 | "                   | "             | "             | "               | "             | "                       | "                          | "          | 16 mm             |
|                          | C2-C3-O1-O2                 | "                   | "             | "             | "               | "             | "                       | "                          | "          | 13 mm             |
| Triple Cover stitch with | C1-C2-C3-O2                 | U - L - C           | 1.5 - 2.5     | 5.0           | B               | WAVE          | Cover Stitch            | 5.0 *                      | N          | 16 mm             |
| 3 thread Wave            | C1-C2-C3-O2 (Reversed Wave) | "                   | "             | "             | "               | "             | "                       | "                          | "          | 16 mm             |
| <b>6 Thread</b>          |                             |                     |               |               |                 |               |                         |                            |            |                   |
| Cover Stitch with        | C1 - C2 - O1                | U - L - C           | 2.5 - 4.0     | 7.5           | A               | OVERLOCK      | Cover Stitch            | 5.0 *                      | N          | 16 mm             |
| 3 thread overlock        | C1 - C3 - O1                | "                   | "             | "             | "               | "             | "                       | "                          | "          | 16 mm             |
| O1 (wide)                | C2 - C3 - O1                | "                   | "             | "             | "               | "             | "                       | "                          | "          | 13 mm             |
| O2 (narrow)              | C1 - C2 - O2                | U - L - C           | 2.5 - 4.0     | 5.0           | B               | "             | Cover Stitch            | 5.0 *                      | N          | 16 mm             |
|                          | C1 - C3 - O2                | "                   | "             | "             | "               | "             | "                       | "                          | "          | 16 mm             |
|                          | C2 - C3 - O2                | "                   | "             | "             | "               | "             | "                       | "                          | "          | 13 mm             |
| Chain Stitch with        | C1 - O1 - O2                | U - L - C           | 2.5 - 4.0     | 7.5           | A               | OVERLOCK      | Chain Stitch            | 4-6 *                      | N          | 16 mm             |
| 4 thread overlock        | C2 - O1 - O2                | "                   | "             | "             | "               | "             | "                       | 4-6 *                      | "          | 13 mm             |
|                          | C3 - O1 - O2                | "                   | "             | "             | "               | "             | "                       | 4-6 *                      | "          | 10 mm             |
| <b>5 Thread</b>          |                             |                     |               |               |                 |               |                         |                            |            |                   |
| Chain Stitch with        | C1 - O1                     | U - L - C           | 2.5 - 4.0     | 7.5           | A               | OVERLOCK      | Chain Stitch            | 4-6 *                      | N          | 16 mm             |
| 3 thread overlock        | C2 - O1                     | "                   | "             | "             | "               | "             | "                       | 4-6 *                      | "          | 13 mm             |
|                          | C3 - O1                     | "                   | "             | "             | "               | "             | "                       | 4-6 *                      | "          | 10 mm             |

Notes : ( U - L - C ) = Upper - Lower - Chain looper

( \* ) = Tension settings on Chain Looper and on Cover/Stitch needles may vary depending on the threads.

