

User's Guide

Onyx™ | 15

Onyx™ | 25

TABLE OF CONTENTS

INTRODUCTION	I	SEWING	19
Intended Use.....	1	Sewing.....	19
Machine Overview.....	1	Start to Sew – Straight Stitch.....	19
Needle Area Overview.....	2	Change Sewing Direction.....	20
Top of Machine.....	2	Finish Sewing.....	20
Accessories.....	3	Straight Stretch Stitch.....	20
Included Accessories (Not Pictured).....	3	Multi-Step Zigzag Stitch.....	21
Presser Feet.....	3	Slant Overedge Stitch.....	21
Accessory Tray.....	4	Closed Overlock Stitch.....	22
Stitch Overview (model Onyx 15).....	5	Blind Hems.....	22
Utility Stitches.....	5	Darning and Mending.....	23
Decorative Stitches.....	5	Repair Large Holes.....	23
Stitch Overview (model Onyx 25).....	6	Repair Tears.....	23
Utility Stitches.....	6	Standard Buttonhole (model Onyx 15).....	24
Decorative Stitches.....	6	Standard Buttonhole (model Onyx 25).....	25
Sewing Guide Reference Chart.....	7	Sew Zippers.....	26
Recommended Settings - Overview.....	7		
Fabrics Guide.....	7	MAINTENANCE	27
Model Onyx 15.....	7	Cleaning the Machine Exterior.....	27
Model Onyx 25.....	7	Removing the Needle Plate and Cleaning the Bobbin Area.....	27
		Cleaning under the Bobbin Area.....	27
PREPARATIONS	8	Troubleshooting.....	28
Unpacking the Machine.....	8	Thread Loops on Underside of Fabric.....	28
Connect to the Power Supply.....	8	Bobbin Thread Breaking.....	28
Pack Away After Sewing.....	8	Bobbin Thread Showing on Top of Fabric.....	28
Free Arm / Removable Accessory Tray.....	9	Bobbin Winding Difficulties.....	28
Presser Foot Lifter.....	9	Fabric Puckers.....	29
Thread Cutter.....	9	Fabric Is Tunneling Under Stitches.....	29
Spool Pin.....	10	Loud Noise When Sewing.....	29
Bobbin Winding.....	11	Machine is Not Feeding Fabric.....	29
Inserting the Bobbin.....	11	Machine Will Not Sew.....	29
Threading the Upper Thread.....	12	The Needles Breaks.....	30
Needle Threader.....	13	Needle Threader Not Working.....	30
Needles.....	13	Skipping Stitches.....	30
Selection Guide — Needle Size, Fabric, Thread.....	14	Stitches Distorted.....	30
Changing the Needle.....	14	Thread Bunching at Beginning.....	31
Thread Tension.....	15	Upper Thread Breaking.....	31
Sew without Feed Teeth.....	15	Service.....	32
Presser Foot Pressure.....	15	Non-Original Parts and Accessories.....	32
Changing the Presser Foot.....	16	Intellectual property.....	33
Attaching the Edge/Quilting Guide.....	16	Technical Specification.....	34
		Importer to the UK.....	35
		MANUFACTURER.....	35
OPERATING YOUR MACHINE	17		
Select a Stitch.....	17		
For sewing the grey stitch patterns.....	17		
For sewing the S1 or S2 stitch patterns.....	17		
Stitch Width Dial & Stitch Length Dial.....	18		
Reverse Sewing.....	18		

INTRODUCTION

INTENDED USE

Optimal use and maintenance are described in these instructions. This product is not intended for industrial or commercial use. Additional assistance, by region, may be found online at www.husqvarnaviking.com

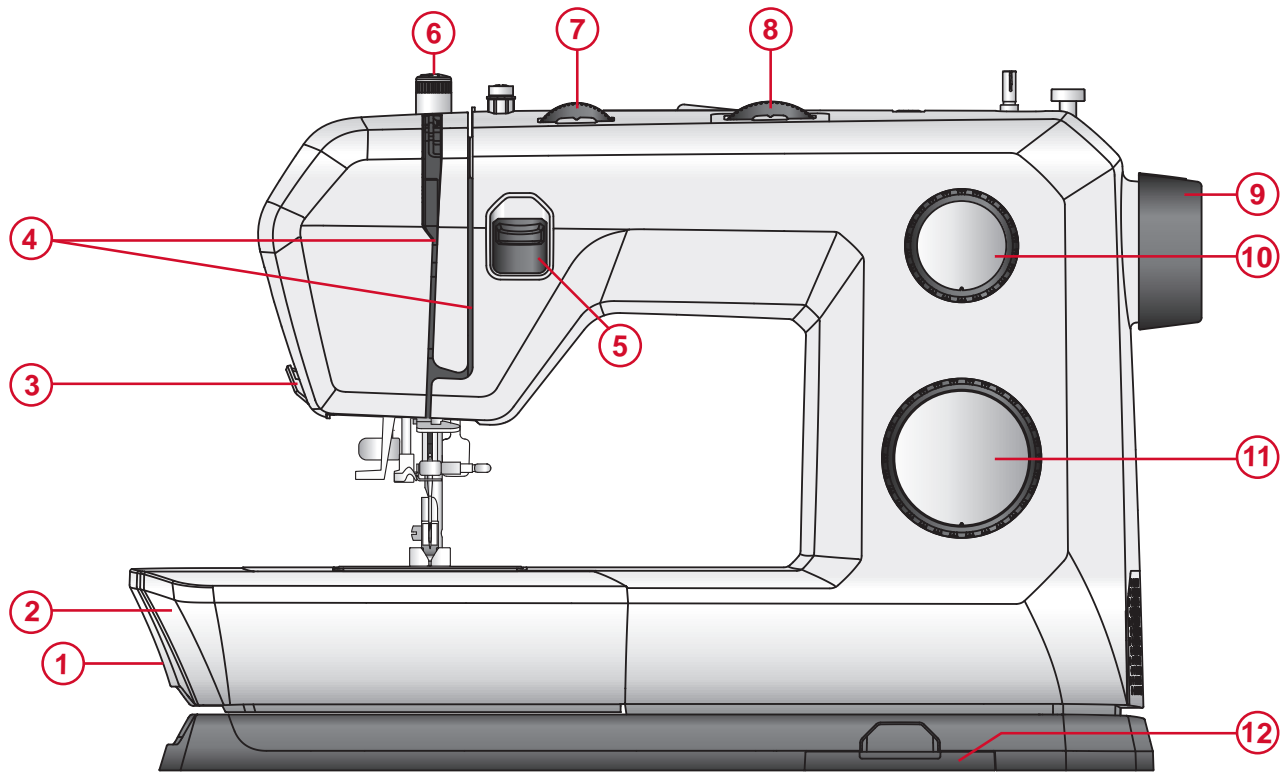

MACHINE OVERVIEW

- 1. Feed Teeth Lever** — move from side to side to engage or disengage the feed teeth. Positioned at the back of the free arm.
- 2. Accessory Tray / Free Arm** — provides a flat surface when sewing and allows storage for your accessories. Remove the accessory tray to use the free arm which makes it easier to sew, e.g., trouser hems and sleeves.
- 3. Thread Cutter** — for trimming thread ends at the end of sewing.
- 4. Threading Slots** — thread paths with tension discs and take up lever.
- 5. Reverse Sewing Lever** — reverses stitching direction, for example, when securing the beginning or ending of a seam.
- 6. Presser Foot Pressure** — controls the pressure the presser foot exerts onto the fabric.
- 7. Thread Tension Dial** — adjustable for setting the desired tension for your stitch, thread and fabric.
- 8. Stitch Width Dial (model Onyx 25)** — controls the width of stitches, making them narrower or wider.
- 9. Hand Wheel** — used to manually control the movement of the needle and the thread take-up lever.
- 10. Stitch Length Dial** — controls the length of stitches, making them shorter or longer as desired. It is also used for stretch stitch selection.
- 11. Stitch Selector Dial** — is used to select stitch patterns and buttonhole settings.
- 12. Sewing Guide Reference Chart** — pull out to view recommendations for your desired stitch and the technique you want to use.

NEEDLE AREA OVERVIEW

1. **Needle Plate** — provides a flat area around presser foot for sewing. Guidelines indicate various seam allowances used to guide fabric while sewing.
2. **Feed Teeth** — feed the fabric under the presser foot when sewing.
3. **Presser Foot** — holds fabric against feed teeth which draw fabric under the presser foot as you sew.
4. **Presser Foot Holder Screw** — loosen the screw to remove the presser foot holder.
5. **Presser Foot Holder** — holds the presser foot.
6. **Built-in Needle Threader** — thread the needle quickly and easily.
7. **Buttonhole Lever** — used for buttonhole sewing.
8. **Thread Guide** — helps maintain thread flow when sewing.
9. **Presser Foot Bar** — accommodates the presser foot holder.
10. **Needle Clamp Screw** — secures the needle.
11. **Needle Thread Guide** — helps maintain thread flow when sewing.
12. **Bobbin Cover Release Button** — push to open the bobbin cover.
13. **Bobbin Cover** — protects the bobbin while sewing.

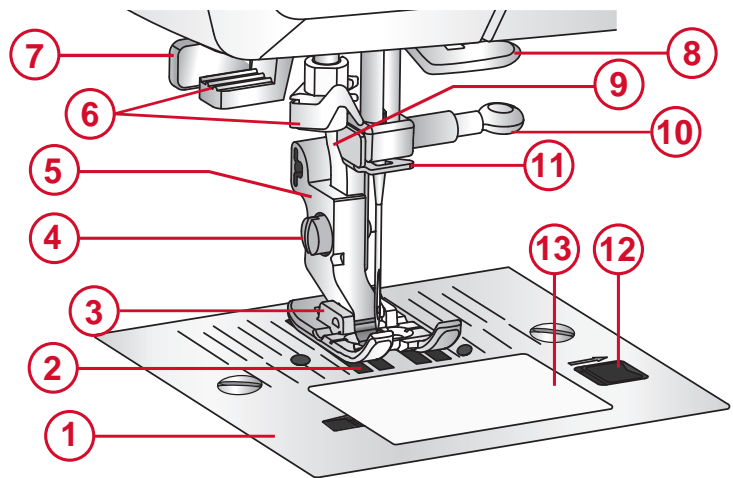

TOP OF MACHINE

1. Thread guides
2. Handle
3. Spool pin
4. Hole for auxiliary spool pin
5. Bobbin winding spindle
6. Bobbin winding stopper
7. Bobbin winding tension disc
8. Thread tension discs
9. Thread take-up lever

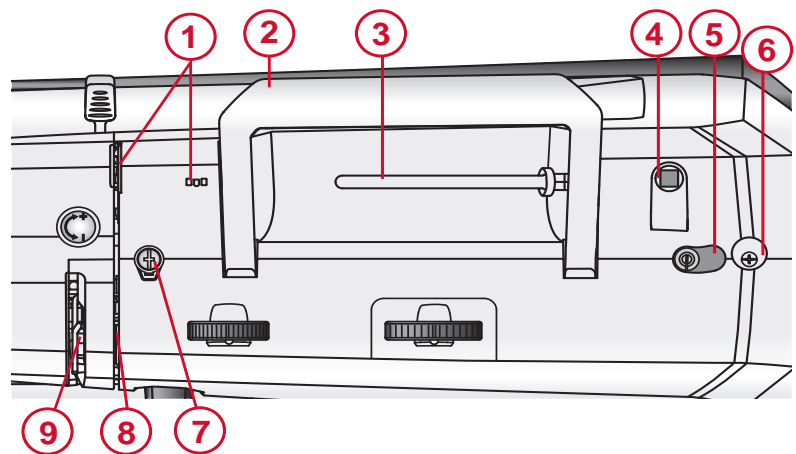

ACCESSORIES

1. Screwdriver
2. Felt pad (x2)
3. Seam ripper/brush
4. Bobbins (x4)
5. Spool cap large
6. Spool cap small
7. Edge/Quilting guide
8. Auxiliary spool pin

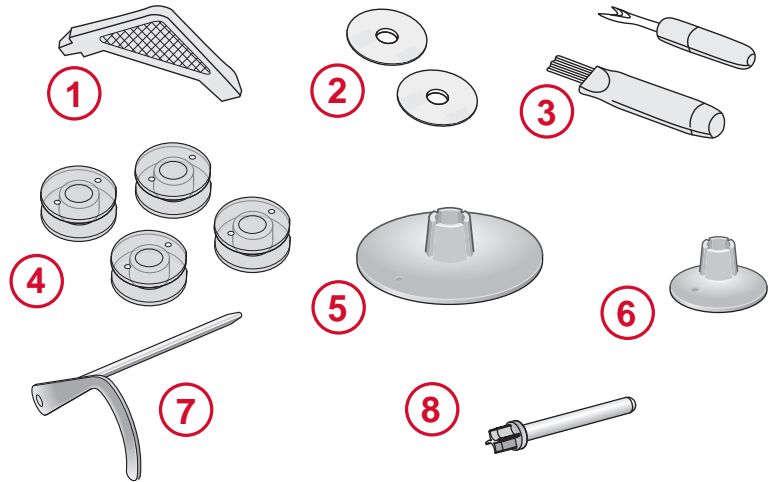

INCLUDED ACCESSORIES (NOT PICTURED)

- Needles
- Foot control
- Power cord

PRESSER FEET



Utility Foot A

Attached on the machine upon delivery. This foot is used mainly for straight stitching and zigzag stitching with a stitch length longer than 1 mm.



Presser Foot B

For sewing close zigzag stitches (satin stitches) with less than 1.0mm stitch length, other utility stitches or decorative stitches, use this foot. The tunnel on the underside of the foot is designed to feed smoothly over the stitches.

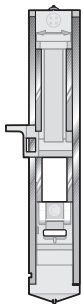

Buttonhole Slider Foot C (model Onyx 25)

This foot has a space in the back to set the size of the buttonhole. The machine will sew a buttonhole to fit that button size.



Buttonhole Foot C (model Onyx 15)

For manual buttonholes. This foot has guidelines to determine buttonhole length. The middle guideline measures 1/2" (12mm) from the needle position. The two tunnels on the underside of the foot ensure smooth feeding over the buttonhole columns. The finger on the back of the foot holds cording for corded buttonholes.



Blind Hem Foot D

This foot is used for blind hem stitches. The inner edge of this foot guides the fabric. The right toe of the foot is designed to ride along the hem edge.



Zipper Foot E

This foot can be snapped on either to the right or to the left of the needle.

This makes it easy to sew both sides of the zipper. Move needle position to right or left to sew closer to zipper teeth or for covering large cording.

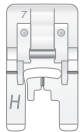

Non-Stick Glide Foot H

This foot, with a non-stick coating underneath, is used when sewing foam, vinyl, plastic, or leather to keep these materials from sticking to the foot.



Edging Foot J

Used for overcasting and seam/overcasting, with stitches that have a stitch width of 5.0 and 5.5mm. Stitches form over the pin which prevents puckering at the edge of the fabric.



Quilter's 1/4" Piecing Foot P (model Onyx 25)

This foot is used when piecing quilt blocks. The foot has seam guide marks at 1/4" (6 mm) and 1/8" (3 mm).

ACCESSORY TRAY



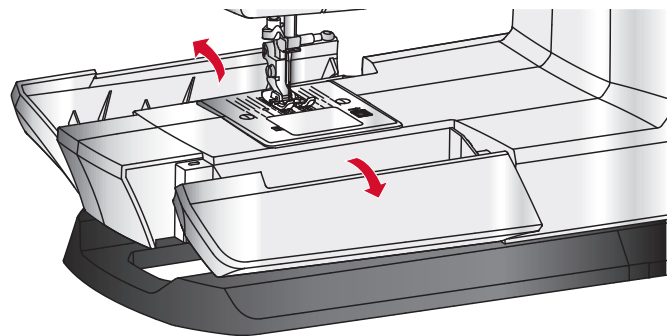









Open the extension table for storing accessories. The accessory tray features special compartments for presser feet and bobbins, plus space for needles and other accessories. Store the accessories in the tray so that they are easily accessible.



STITCH OVERVIEW (MODEL ONYX 15)

Utility Stitches

The stitches described in the below chart are utility stitches, used mainly for utility sewing. When sewing, use a thread tension between 3–5. Always test sew on a piece of scrap fabric, and adjust the tension if necessary.

		Application
 Straight Stitch Center Position	A	The basic stitch used for sewing. The most common use for a straight stitch is to sew two pieces of fabric together.
 Straight Stretch Stitch	A	Stronger than a regular straight stitch, on stretch knit fabrics, because it locks three times — forward, backward and forward again. Use it to reinforce seams of sportswear and for curved seams that take a lot of strain.
 Zigzag Stitch	A	A very versatile stitch for decorative sewing, applique, attaching trims, and more.
 Multi-Step Zigzag Stitch	B	Finish seam allowances to prevent the fabric from unravelling. When seam finishing, the smaller step of the stitches will help keep fabric more flat than a regular zigzag. It can also be used for mending tears and sewing elastic.
 Overlock Stitch	B	Sew a seam and overcast in one step. For medium and medium/heavy stretch fabrics.
 Blind Hem Stitch	D	Sew hems that are practically invisible from the right side of the fabric. It is used for skirts, dresses, trousers, curtains, etc, made with non-stretch fabrics.
 Stretch Blind Hem Stitch	D	Sew hems that are practically invisible from the right side of the fabric. It is used for garments and other projects made with stretch knit fabrics.
 Slant Overedge Stitch	B	Seam and overcast in one step. For medium and heavy stretch fabrics.
 Closed Overlock Stitch	B	Sew decorative hems and overlapped seams, belts and bands. For medium/heavy stretch fabrics.
 Honeycomb Stitch	B	For elastic insertion, decorative stitching, smocking, couching and hemming.
 4-step Buttonhole	C	Sew buttonholes on home decór, garments, crafts and more.













Decorative Stitches

Your machine also features decorative stitches. The stitches not described in the previous chart are decorative stitches. When sewing the decorative stitches, make sure to use a stabilizer underneath the fabric for better appearance. Use a thread tension between 3–5. Always test sew on a piece of scrap fabric, and adjust the tension if necessary.

STITCH OVERVIEW (MODEL ONYX 25)

Utility Stitches

The stitches described in the below chart are utility stitches, used mainly for utility sewing. When sewing, use a thread tension between 3–5. Always test sew on a piece of scrap fabric, and adjust the tension if necessary.

			Application
	Straight Stitch Center Position	A	The basic stitch used for sewing. The most common use for a straight stitch is to sew two pieces of fabric together.
	Straight Stretch Stitch	A	Stronger than a regular straight stitch, on stretch knit fabrics, because it locks three times — forward, backward and forward again. Use it to reinforce seams of sportswear and for curved seams which take a lot of strain.
	Zigzag Stitch	A	A very versatile stitch for decorative sewing, applique, attaching trims, and more.
	Multi-Step Zigzag Stitch	B	Finish seam allowances to prevent the fabric from unravelling. When seam finishing, the smaller step of the stitches will help keep fabric more flat than a regular zigzag. It can also be used for mending tears and sewing elastic.
	Overlock Stitch	B	Sew seam and overcast in one step. For medium and medium/heavy stretch fabrics.
	Blind Hem Stitch	D	Sew hems that are practically invisible from the right side of the fabric. It is used for skirts, dresses, trousers, curtains, etc, made with non-stretch fabrics.
	Stretch Blind Hem Stitch	D	Sew hems that are practically invisible from the right side of the fabric. It is used for garments and other projects made with stretch knit fabrics.
	Slant Overedge Stitch	B	Seam and overcast in one step. For medium and heavy stretch fabrics.
	Closed Overlock Stitch	B	Sew decorative hems and overlapped seams, belts and bands. For medium/heavy stretch fabrics.
	Honeycomb Stitch	B	For elastic insertion, decorative stitching, smocking, couching and hemming.
	1-step Buttonhole	C	Sew buttonholes on home décor, garments, crafts and more.

Decorative Stitches

Your machine also features decorative stitches. The stitches not described in the previous chart are decorative stitches. When sewing the decorative stitches, make sure to use a stabilizer underneath the fabric for better appearance. Use a thread tension between 3–5. Always test sew on a piece of scrap fabric, and adjust the tension if necessary.

Sewing Guide Reference Chart

Consult the Sewing Guide Reference Chart for a fast and easy way to select the best stitch, stitch length, stitch width (Onyx 25), thread tension, presser foot and presser foot pressure for your sewing technique and fabric.

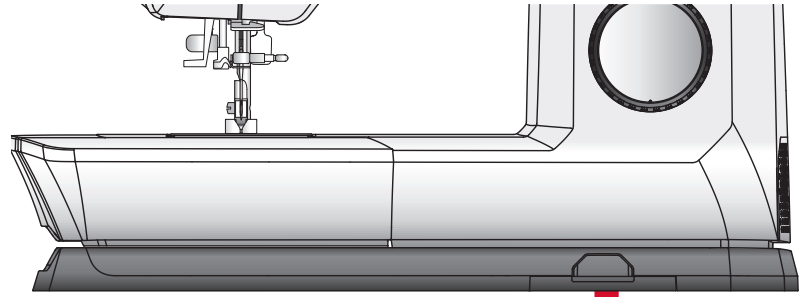

Stitch	Foot	Pressure	Tension	Length	Width
↔	↔	A	3-5	L 2.5	
↔	↔	B	5-7	L 1.0	
↔	↔	C	3-5	L 1.0	
↔	↔	A	2-4	L 4.0	
↔	↔	B	4-6	L 2.0	
↔	↔	A	3-5	L 2.5	
↔	↔	C	2-4	L 0.5	

Model Onyx 15

Stitch	Foot	Pressure	Tension	Length	Width
↔	↔	A	3-5	L 2.5	W 0.0
↔	↔	B	5-7	L 1.0	W 5.0
↔	↔	C	3-5	L 1.5	W 1.5
↔	↔	A	2-4	L 4.0	W 0.0
↔	↔	B	4-6	L 2.0	W 3-4
↔	↔	A	3-5	L 2.5	W 0.0
↔	↔	C	2-4	L 0.5	W 5.0

Model Onyx 25

Recommended Settings - Overview

1. Fabric
2. Presser foot pressure
3. Sewing technique
4. Stitch
5. Presser foot
6. Thread tension
7. Stitch length
8. Stitch width (Onyx 25)

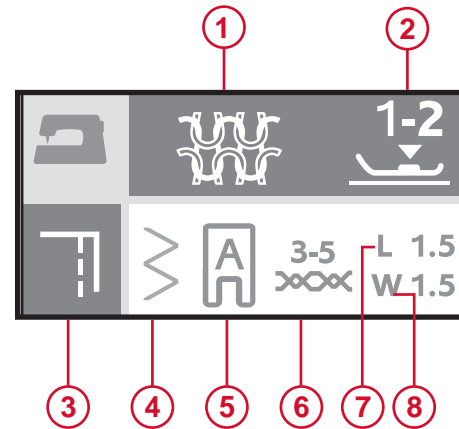

Fabrics Guide



WOVEN FABRICS: for stable fabrics that have no stretch. Usually woven.



STRETCH FABRICS: for fabrics that have stretch. Usually knit.



LEATHER/VINYL: for suede, real leather and for artificial leather and suede.

PREPARATIONS

UNPACKING THE MACHINE

After lifting the machine out of the box and removing all packing material and the plastic bag, wipe the machine, particularly around the needle and needle plate to remove any oil before sewing.

Note: Your sewing machine is adjusted to provide the best stitch result at normal room temperature. Extreme hot and cold temperatures can affect the sewn result.

CONNECT TO THE POWER SUPPLY

Among the accessories you will find the power cord and the foot control.

On the bottom right side of the sewing machine, you will find the connecting sockets and the ON/OFF button.

1. Connect the power cord to the rear socket on the bottom right side of the machine (A). Plug the cord into the wall socket.
2. Press the ON/OFF switch (B) to "I" to turn on power and light.

Sewing speed is regulated by pressing the foot control.

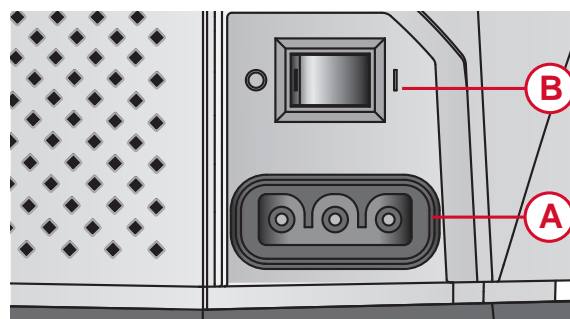

For the USA and Canada

This sewing machine has a polarized plug (one blade wider than the other). To reduce the risk of electric shock, this plug is intended to fit in a polarized outlet only one way. If the plug does not fit fully in the outlet, reverse the plug. If it still does not fit, contact a qualified electrician to install the proper outlet. Do not modify the plug in any way.

PACK AWAY AFTER SEWING

1. Switch the main switch off. After switching off, residual power may still remain in the machine. This may cause the light to stay on for a few seconds while the power is consumed. This is normal behavior for an energy efficient appliance.
2. Unplug the cord from the wall socket and then from the machine.
3. Wind the cord around the foot control for easy storage.
4. Place all accessories in the accessory tray. Slide the tray on to the machine around the free arm.
5. Place the foot control and cord in the space above the free arm.
6. Place the soft cover on the machine to help protect it from dust and lint.

FREE ARM / REMOVABLE ACCESSORY TRAY

Store presser feet, bobbins, needles and other accessories in the accessory tray so that they are easily accessible.

Keep the accessory tray on the machine to provide a larger, flat work surface.

Use the free arm to facilitate sewing trouser legs and sleeve hems. To use the free arm, slide off the accessory tray. When attached, a hook keeps the accessory tray securely attached to the machine. Remove the tray by sliding it to the left.

When the accessory tray is removed from the machine, open the door by putting a finger in the groove at the left side of the accessory box (A) and carefully pull it open. Push the door closed before putting the tray back onto the machine.

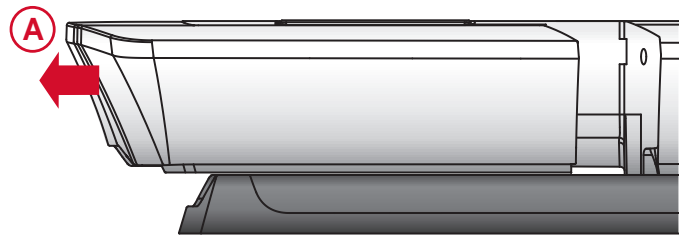

PRESSER FOOT LIFTER

The presser foot lever is located at the back side of the sewing machine head. The lever is used to raise and lower the presser foot. Raise the lever up for machine threading, lower it for sewing.

By raising the presser foot lever and then pressing it farther upwards, the lift height of the presser foot is increased to an extra height allowing you to place thick fabric layers under the foot.

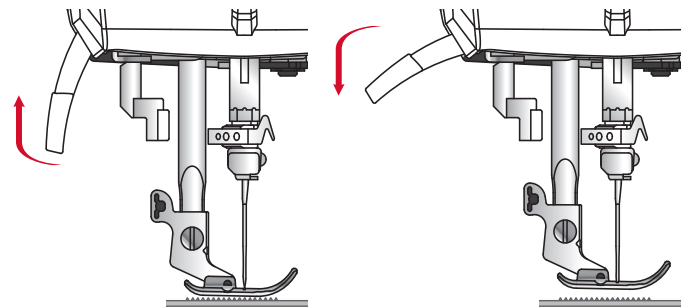

THREAD CUTTER

To use the thread cutter, pull the thread from back to front as illustrated. Doing this will leave the thread ends long enough so that the needle doesn't become unthreaded when you start to sew again.

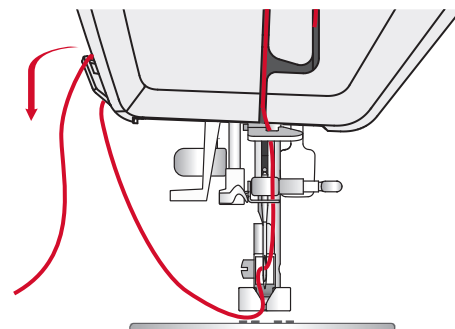

SPOOL PIN

Your machine has two spool pins, a main spool pin and an auxiliary spool pin. The spool pins are designed for all types of thread. The main spool pin is adjustable and can be used both in a horizontal position (the thread reels off the spool) and a vertical position (the thread spool rotates). Use the horizontal position for regular sewing threads and the vertical position for large spools or specialty threads.

Main Spool Pin

Place the thread spool on the spool pin. Make sure that the thread reels off the spool counter clockwise and slide on a spool cap. Use a spool cap slightly larger than the thread spool. For narrow thread spools (A), use a smaller spool cap in front of the spool. For large thread spools (B), use a larger spool cap in front of the spool. The flat side of the spool cap should be pressed firmly against the spool. There should be no space between the spool cap and the thread spool.

Note: Not all thread spools are manufactured in the same way. If you experience problems with the thread, turn it in the opposite way or use the vertical position.

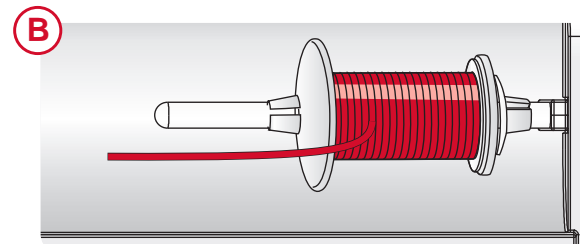
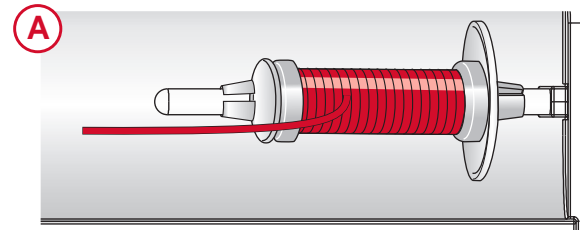

Auxiliary Spool Pin

The Auxiliary Spool Pin is used when winding a bobbin thread from a second spool of thread or when sewing with large spools or with specialty threads. Insert the Auxiliary Spool Pin into the designated hole at the top of the machine (A). Place a felt pad under the thread spool. This is to prevent the thread from reeling off too fast. Do not place a spool cap on top of the spool pin as that would prevent the spool from rotating.

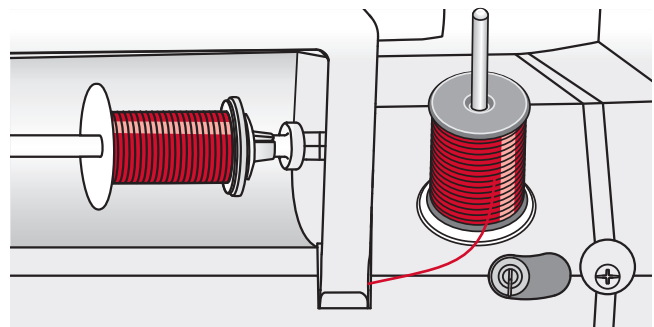
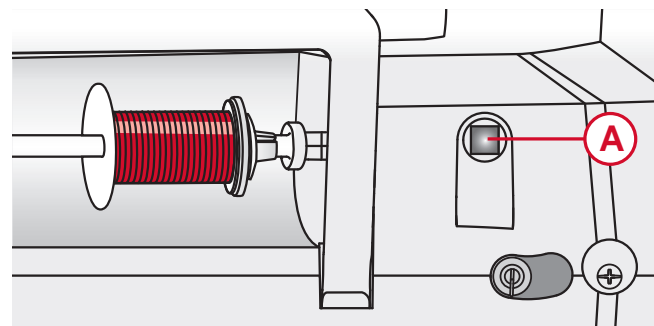

BOBBIN WINDING

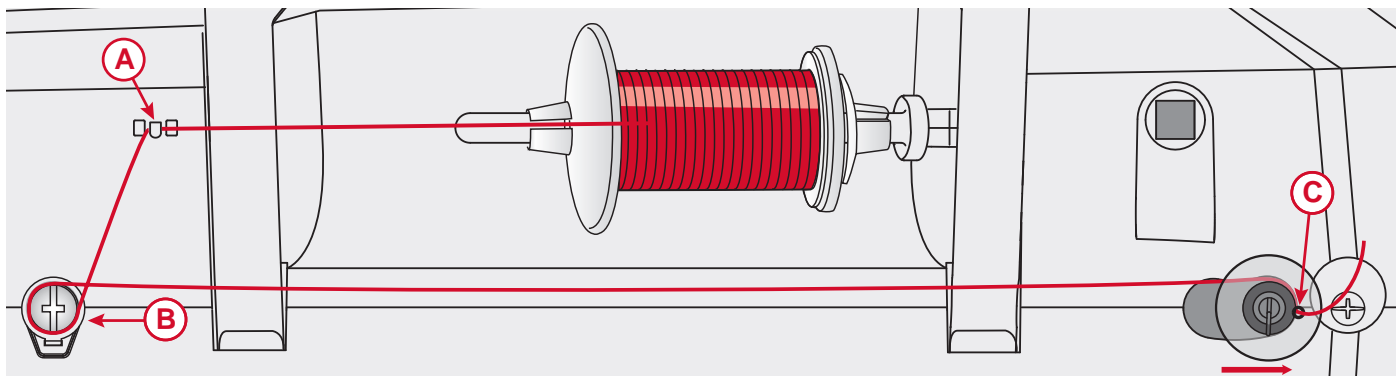

1. Place the thread spool on the spool pin. Slide a spool cap firmly against the spool.
2. Place the thread into the thread guide (A) from front to the back. Bring the thread clockwise around the bobbin winding tension disc (B), making sure that the thread is pulled snugly between the discs.
3. Thread through the hole in the bobbin (C) from the inside to the outside.
4. Place the bobbin on the bobbin winding spindle. Make sure the bobbin is pushed down firmly.
5. Push the bobbin winding spindle to the right. Hold the thread end, and press the foot control to start winding. After a few turns, take your foot off the foot control to stop winding. Cut the excess thread tail above the bobbin, making sure to trim it close to the bobbin. Step on the foot control to resume winding. When the bobbin is full, the bobbin winding will slow down and stop automatically.
6. Push the bobbin winding spindle to the left. Remove the bobbin and cut the thread.

Note: When the bobbin winding spindle is pushed to the right, the machine will not sew. Make sure to push the bobbin spindle back to the sewing position (left) before sewing.

INSERTING THE BOBBIN

Make sure that the needle is fully raised and the machine is turned off before inserting or removing the bobbin.

1. Open the bobbin cover by pushing the release button to the right (A). Remove the cover (B).
2. Insert the bobbin in the bobbin case with the thread running in a counterclockwise direction.
3. Draw the thread at the arrow markings into the stitch plate thread guide from (C) to (D).
4. Pull the thread at the arrow markings into the stitch plate thread guide from (D) to (E). To cut off excess thread pull thread back over the cutting off blade at point (E). Close the bobbin cover plate.
5. Replace the bobbin cover.

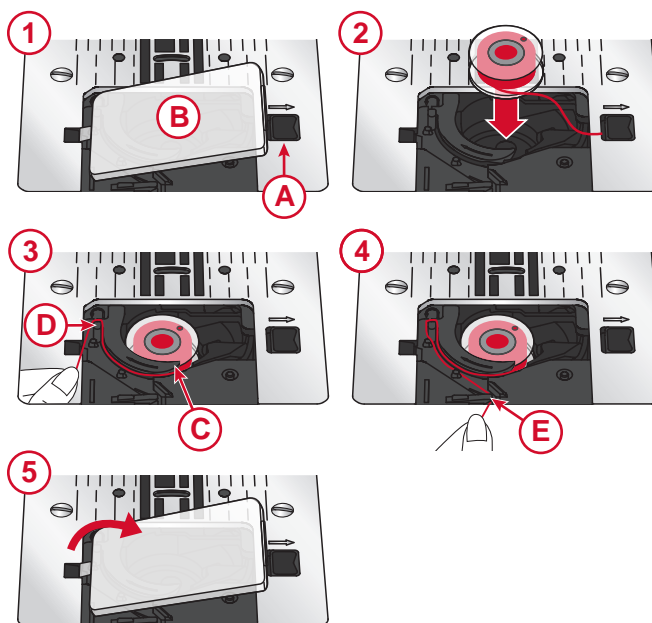

THREADING THE UPPER THREAD

Important! Make sure that the presser foot is raised and the needle is in its highest position by turning the handwheel toward you. This is very important to help ensure that the machine is correctly threaded. Not doing so can result in poor stitch quality when you start to sew.

1. Place the thread on the spool pin and fit the appropriately sized spool cap.
2. Pull the thread into the thread guide (A) from front to the back and thread guide (B) from back to front. Pull the thread between the tension discs (C).
3. Continue bringing the thread down through the right threading slot, around the U-turn, then back upwards through the left threading slot.

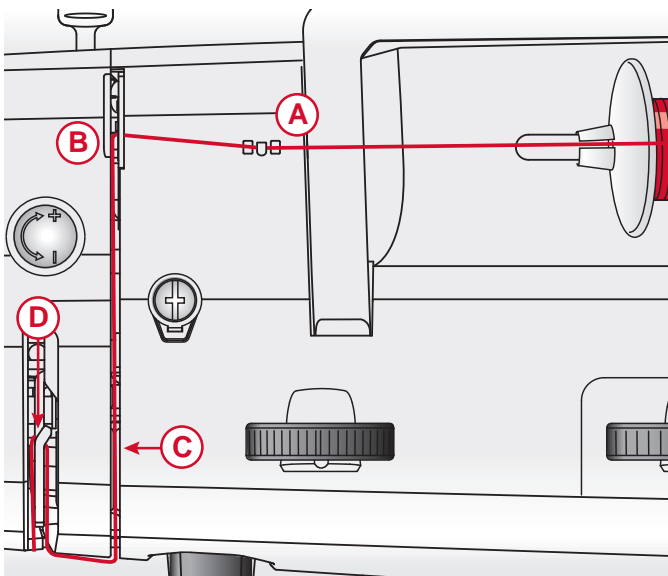

Machine from above

4. Bring the thread from the right into the take-up lever (D) and down in the left-hand threading slot, into the lower thread guide (E) and to the needle thread guide (F).
5. Thread the needle from front to back.

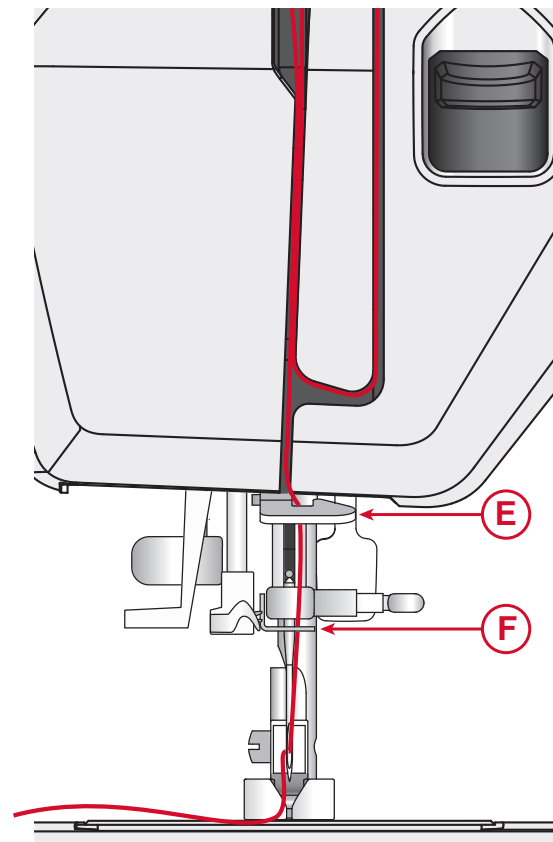

Machine from front

NEEDLE THREADER

The built-in needle threader allows you to thread the needle quickly and easily.

The needle must be in its highest position to use the built-in needle threader. Turn the hand wheel towards you until the needle is in its highest position. It is also recommended that you lower the presser foot.

1. Use the handle (A) to pull the needle threader all the way down. The metal flanges cover the needle. A small hook will pass through the needle eye (B).
2. Place the thread from the back over the thread guide (C) and under the small hook (D).
3. Let the needle threader gently swing back. The hook pulls the thread through the needle eye and forms a loop behind the needle. Pull the thread loop out behind the needle.
4. Raise the presser foot and place the thread under it.
5. Pull out about 6–8" (15–20cm) of thread beyond the needle eye. This will prevent the machine from coming unthreaded when you start to sew.

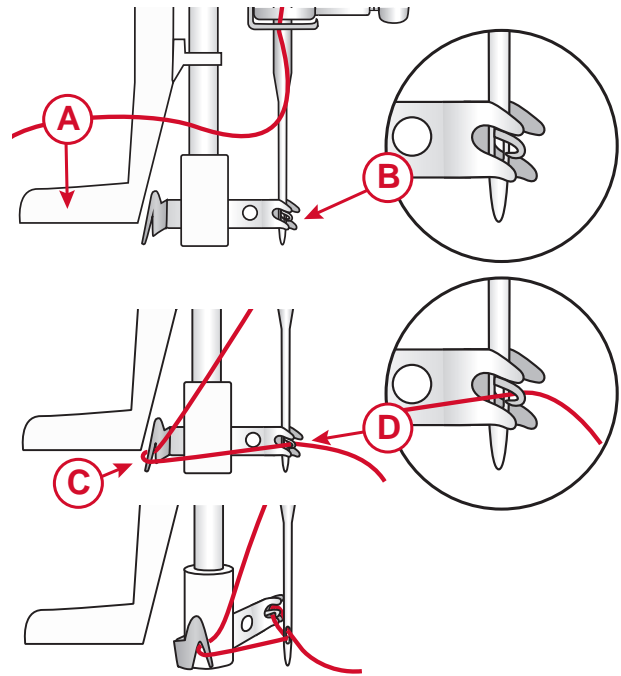

Note: The needle threader is designed to be used for size 75-100 needles. You cannot use the needle threader for size 70 needles or smaller, wing needles or twin needles. There are also some optional accessories that require manual threading of the needle. When threading the needle manually, make sure that the needle is threaded from front to back.

NEEDLES

The sewing machine needle plays an important role in successful sewing. Use only quality needles. We recommend needles of system 130/705H. The needle package included with your machine contains needles of the most frequently used sizes.



Be sure to match the needle to the thread you are using. Heavier threads require a needle with a larger needle eye. If the needle eye is too small for the thread, the needle threader may not work properly.

Universal Needle



Universal needles have a slightly rounded point and come in a variety of sizes. For general sewing in a variety of fabric types and weights.

Stretch Needle



Stretch needles have a ball point and a special scarf to eliminate skipped stitches when there is a flex in the fabric. For knits, swimwear, fleece, synthetic suedes and synthetic leathers.

Denim Needle



Denim needles have a sharp point to penetrate tightly woven fabrics without deflecting the needle. For canvas, denim and microfibers.

Note: To avoid needle breakage, use only medium/low speed and the recommended needle on thick fabrics works.

Important Needle Information



Change the needle often. As a general rule, needles should be changed every 6-8 hours of actual stitching time.

Always use a straight needle with a sharp point and make sure the point is not bent or damaged (A).

A damaged needle (B) can cause skipped stitches, breakage or snapping of the thread. It can also damage the needle plate.

Do not use asymmetrical twin needles (C), as they can damage your sewing machine.

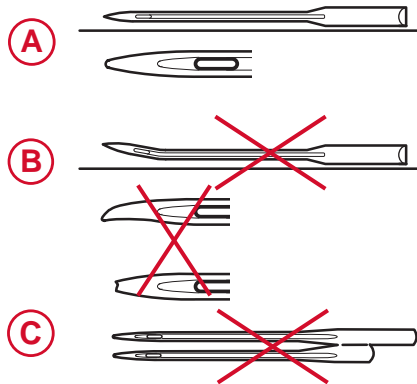

SELECTION GUIDE — NEEDLE SIZE, FABRIC, THREAD

Needle Size	Fabric	
70 (9) 80 (12)	Lightweight fabrics: Fine cotton, voile, silk, muslin, interlock, tricot, jersey, crepe, polyester, chiffon, organza, organdy	Light duty all-purpose thread
80 (12) 90 (14)	Medium weight fabrics: Quilting cotton, satin, double knit, lightweight wool, rayon, polyester, lightweight linen	Use polyester threads on synthetic fabrics and all-purpose or cotton thread on natural fabrics for best results.
90 (14)	Medium weight fabrics: Firm woven, medium weight linen, cotton/polyester blend, terrycloth, chambray, double knit	
100 (16)	Heavy weight fabrics: Canvas, wool, denim, home decor, fleece, heavy knit	Polyester or all-purpose thread.

CHANGING THE NEEDLE

Note: Before you begin changing the needle, it can be helpful to place a small piece of paper or fabric underneath the needle area, over the hole in the needle plate, so that the needle doesn't accidentally fall down into the machine.

1. Loosen the needle clamp screw. If it feels tight, use the screwdriver from your accessories to aid with loosening the screw.
2. Remove the needle.
3. Push the new needle upwards into the needle clamp with the flat side of the needle away from you.
4. When the needle will go up no further, tighten the screw securely.

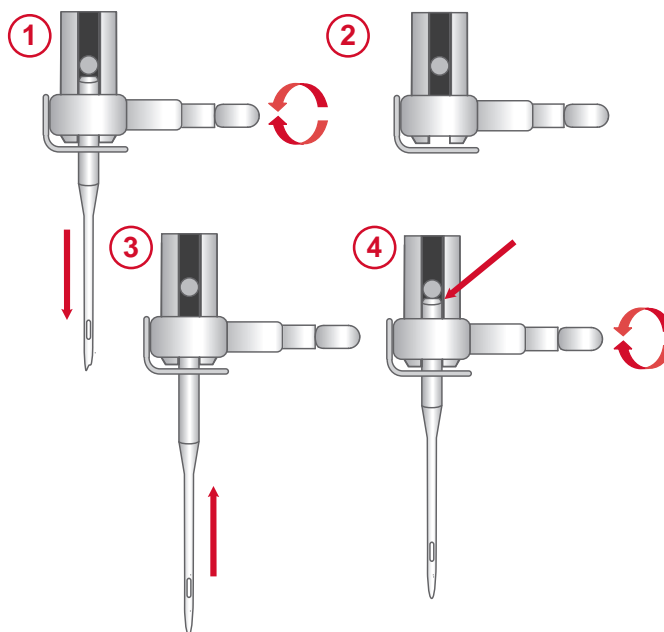

THREAD TENSION

To set the thread tension, turn the dial on top of the machine. Depending on the fabric, thread, etc, the tension may need to be adjusted. For the best stitch appearance and durability, make sure the needle thread tension is correctly adjusted. For general sewing, the threads evenly meet between the two layers of fabric (A).

If the bobbin thread is visible on the top side of the fabric, the needle thread tension is too tight (B). Reduce the needle thread tension.

If top thread is visible on the underside of the fabric, the needle thread tension is too loose (C). Increase the needle thread tension.

For decorative stitches and buttonholes, the top thread should be visible on the underside of the fabric.

Make a few tests on a scrap piece of the fabric you are going to sew and check the tension.

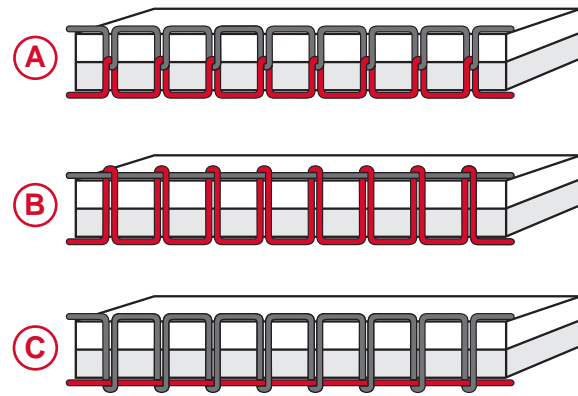

SEW WITHOUT FEED TEETH

When sewing on buttons or doing other sewing techniques where you don't want the fabric to feed, you need to lower the feed teeth.

The feed teeth lever is found at the back of the free arm.

1. Lower the feed teeth by moving the lever to the “Feed Teeth Down” position.
2. Raise the feed teeth by moving the lever to the “Feed Teeth Up” position.

Note: The feed teeth will not raise immediately when the lever is switched. Turn the hand wheel toward you one full turn or start sewing to re-engage the feed teeth.

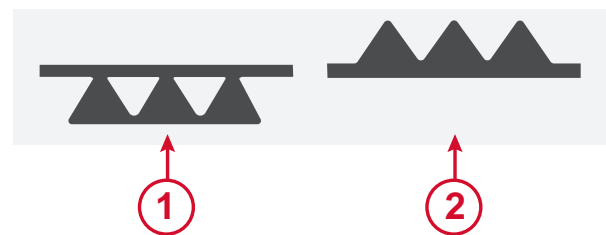

PRESSER FOOT PRESSURE

The presser foot pressure is used to control the amount of pressure that the presser foot exerts onto the fabric, to ensure smooth feeding of the fabric while sewing. The presser foot pressure has been pre-set to the standard value "2". Though it needs no adjustment for most fabrics, it can be adjusted for very thick or very thin fabric - increase for heavy weight fabrics, decrease for lightweight fabrics.

Note: If the dial is turned counterclockwise too much, it could come off. If this happens, simply replace the dial and turn it clockwise until it stays in place.

Note: If the dial is turned clockwise until it comes to a stop, it has reached the maximum pressure available. Do not try to turn the dial any further!

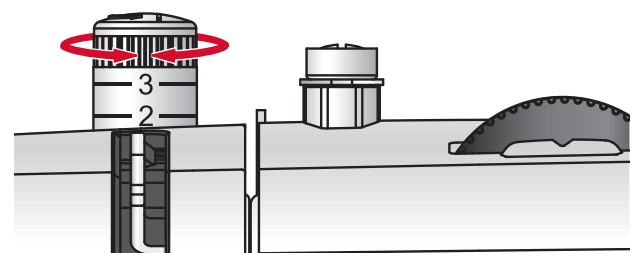

CHANGING THE PRESSER FOOT

1. Make sure the needle is in the highest position. Pull the presser foot towards you.
2. Line up the cross pin on the foot with the gap in the presser foot ankle. Press back until the foot snaps into place.

Note: If you find it difficult to place the presser foot in the correct position, keep the release button pressed while lowering the presser foot. Use your thumb to carefully guide the presser foot into the correct position and it will snap into place.

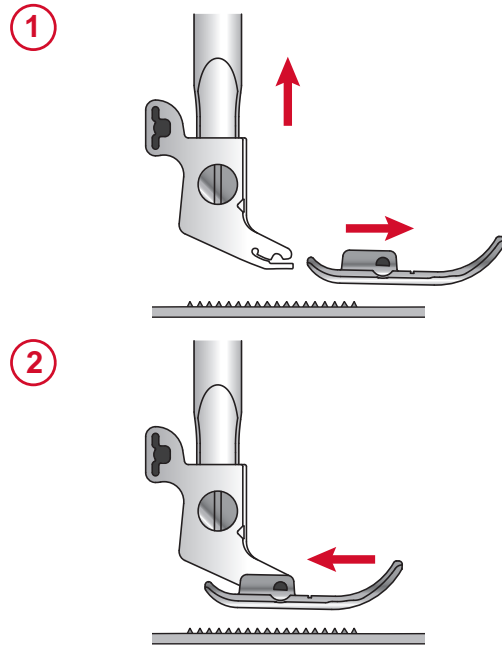

ATTACHING THE EDGE/QUILTING GUIDE

Attach the edge/quilting guide in the slot (A) as illustrated. Adjust as needed for hems, pleats, quilting, etc.



Turn power switch to off ("O") when carrying out any of the above operations!

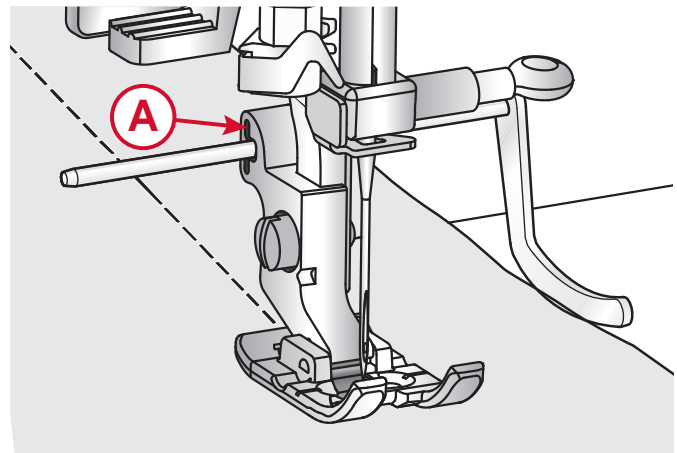

OPERATING YOUR MACHINE

SELECT A STITCH

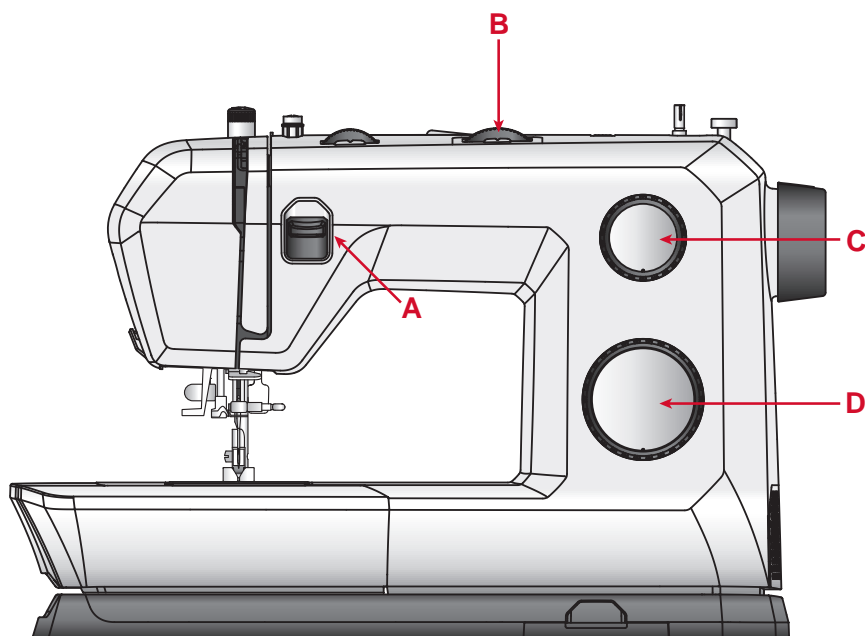

Model Onyx 15

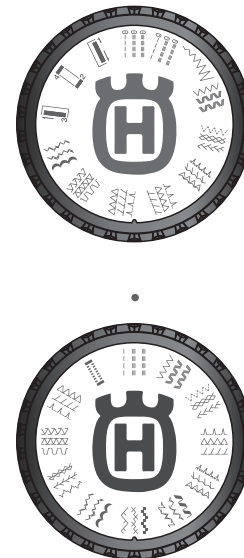

Model Onyx 25

- A. Reverse sewing lever
- B. Stitch width dial (model Onyx 25)
- C. Stitch length dial
- D. Stitch selector dial

The stitch selector dial is used to select the stitch you want to sew. The dial can be turned to the left or to the right.

For sewing the grey stitch patterns

Turn the Stitch Selector Dial until it clicks in place under the dot directly above the dial on the machine.

Set the Stitch Length Dial according to the length you want. It can be set anywhere between 0.5 and 4, with 4 being the longest setting.

For straight stitch sewing, the Stitch Width Dial (Onyx 25 only) can be set at 0 for the center needle position or 6 for the left needle position.

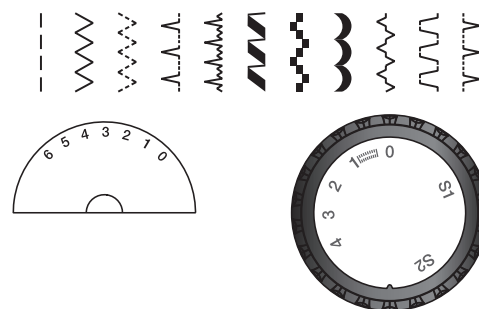

Stitch Width Dial

Stitch Length Dial

For sewing the S1 or S2 stitch patterns

Turn the Stitch Selector Dial until it clicks in place under the dot directly above the dial on the machine.

Set the Stitch Length Dial so that the S1 or S2 is lined up with the dot above this dial. This dial must be set at the S1 marking for the blue stitches or the S2 marking for the grey stitches, or the stitch pattern will not sew.

Set the Stitch Width Dial (Onyx 25 only) to a wide setting (4-6). If desired, you can set it to a lower setting, depending on the look you want.

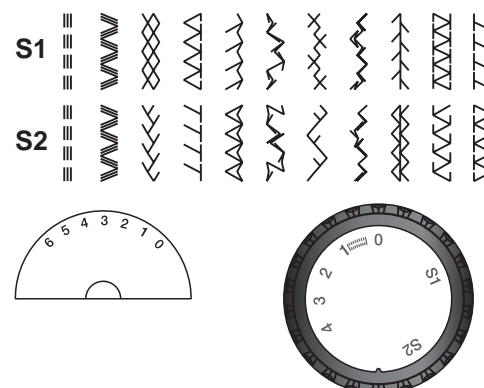

Stitch Width Dial

Stitch Length Dial

STITCH WIDTH DIAL & STITCH LENGTH DIAL

Function of stitch width dial (model Onyx 25)

The maximum zigzag stitch width for zigzag stitching is 6mm; however, the width can be reduced on any pattern. The width increases as you move zigzag dial from "0" - "6". (1)

Function of stitch length dial while zigzag stitching

Set the Stitch Selector Dial to zigzag. The density of zigzag stitches increase as the setting of stitch length dial approaches "0". Standard zigzag stitches are usually achieved at "3" or below. Dense zigzag stitches are called satin stitches.

Function of stitch length dial for straight stitching

For straight stitch sewing, turn the Stitch Selector Dial to the straight stitch setting. Turn the Stitch Length Dial, and the length of the individual stitches will decrease as the dial approaches "0". The length of the individual stitches will increase as the dial approaches "4". Generally speaking, use a longer stitch length when sewing heavier weight fabrics or when using a thicker needle or thread. Use a shorter stitch length when sewing lighter weight fabrics or when using a finer needle or thread.

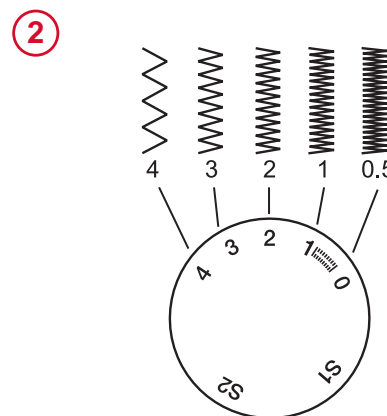
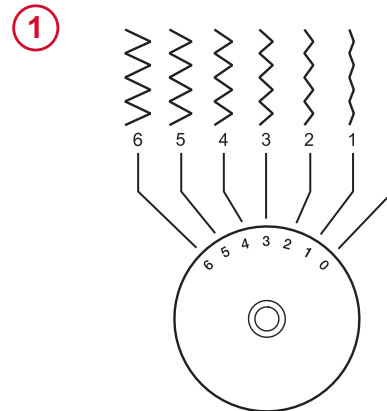

REVERSE SEWING

To secure the beginning and the end of a seam, press down the reverse lever. Sew a few reverse stitches. Release the lever and the machine will sew forward again.

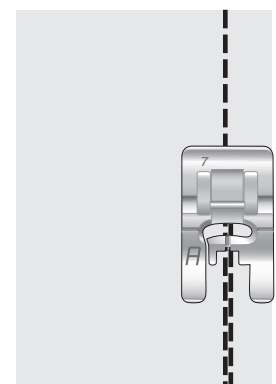





SEWING

SEWING

Next to each stitch or sewing technique described in this section of the manual is a chart showing the recommended settings and presser foot. See sample of the chart to the right.

Note: Some fabrics have a lot of excess dye which can cause discoloration on other fabric but also on your sewing machine. This discoloring may be very difficult or impossible to remove. Fleece and denim fabric, especially in red and blue, often contain a lot of excess dye. If you suspect that your fabric/ready-to-wear garment contains a lot of excess dye, always pre-wash it before sewing to avoid the discoloring.

Note: For best sewing result, use the same thread on top and bobbin. If sewing with specialty/decorative threads, use regular sewing thread in the bobbin.

				
	3.5	2.5	3-5	A

(A) **(B)** **(C)** **(D)** **(E)**

- A. Stitch
- B. Stitch width in mm
- C. Stitch length in mm
- D. Thread tension
- E. Presser foot

START TO SEW – STRAIGHT STITCH





Set your machine for straight stitch (see chart to the right).

Raise the presser foot and position the fabric under it, next to a seam allowance guide line on the needle plate. On the bobbin cover there is a 1/4" (6mm) guide line.

Place the top thread underneath the presser foot.

Lower the needle to the point where you want to start. Bring the threads toward the back and lower the presser foot. Press the foot control. Gently guide the fabric along the seam guide letting the machine feed the fabric (A). If the bobbin thread isn't pulled up, it will be automatically as you start to sew.

To secure the beginning of a seam, press and hold the reverse lever. Sew a few reverse stitches. Release the reverse lever and the machine will sew forward again (B).

				
	0	2-4	3-5	A

Set up for straight stitch

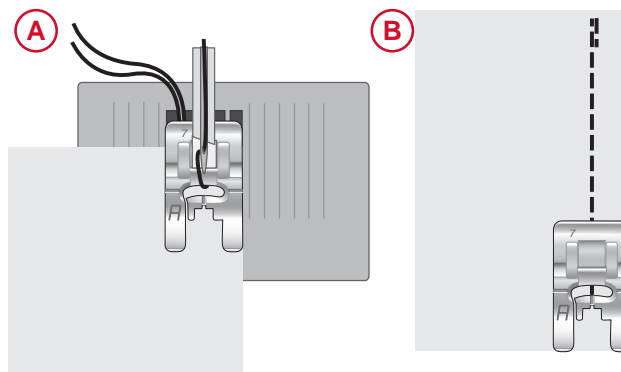

CHANGE SEWING DIRECTION

To change sewing direction, stop the machine and lower the needle.

Raise the presser foot.

Pivot the fabric around the needle to change sewing direction as desired. Lower the presser foot and continue sewing in the new direction.

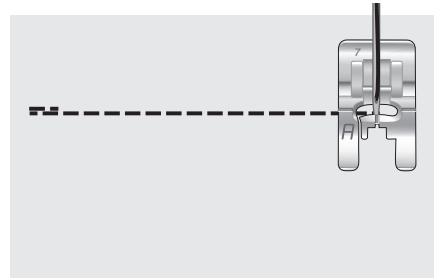

FINISH SEWING

Press and hold the Reverse lever and sew a few stitches in reverse when you reach the end of the seam. Release the button and sew forward again to the end of the seam. This will secure the seam so the stitches don't unravel.

Turn the handwheel toward you to raise the needle to its highest position. Raise the presser foot and remove the fabric, pulling the threads to the back.

Pull the threads up and into the thread knife so that the threads are cut to the proper length and your needle won't come unthreaded when you start the next seam.

STRAIGHT STRETCH STITCH

This stitch is stronger than regular straight stitch, due to the fact that it is a triple and stretch stitch. The Straight Stretch Stitch can be used for heavy stretch fabrics, for crotch seams which are subject to considerable strain, and for topstitching heavy fabrics.

Carefully guide the fabric while sewing as the fabric moves back and forth.

	0	S1,S2	3-5	A



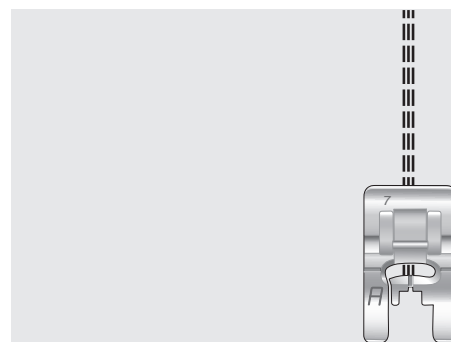

Set up for Straight Stretch Stitch



MULTI-STEP ZIGZAG STITCH

Multi-step zigzag stitch is used to overcast raw edges. Make sure the needle pierces the fabric on the left side and overcasts the edge on the right side.

The stitch can also be used as a stretch stitch to allow seams to stretch when sewing knit fabrics.

				
	3-5	1	3-5	B

Set up for multi-step zigzag stitch







SLANT OVEREDGE STITCH

The slant overedge stitch sews the seam and overcasts the edge all at one time, perfect for stretch fabrics. This stitch is more elastic than normal seams, very durable and quickly sewn.

Place the fabric under the presser foot aligning the edge of the presser foot with the edge of the fabric. Once the seam is finished, trim excess fabric outside the seam.

Tip: You can also use the Blind Hem Foot to sew at the very edge of the fabric. Adjust the extension on the foot, and let it guide along the fabric edge. Always test sew on a piece of scrap fabric first, as the result might vary due to the fabric weight and quality.

				
	3-5	S1	3-5	B



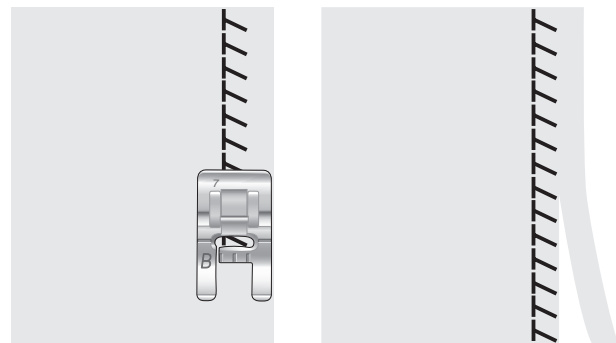

Set up for slant overedge stitch



CLOSED OVERLOCK STITCH

The closed overlock stitch can be used for sewing medium to heavier weight stretch fabrics.

Use this stitch to hem stretch fabrics (A) and for belt loops (B). Fold a hem to the wrong side and stitch with closed overlock stitch from the right side. Trim away excess fabric.





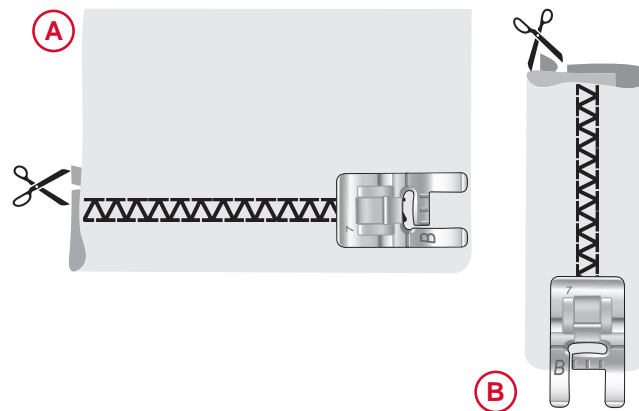

				
	5	S1	3-5	B

Set up for closed overlock stitch



BLIND HEMS

The blind hem stitch is used to make invisible hems on skirts, trousers and home décor projects. There are two types of blind hem; one is recommended for medium to heavy woven fabric (1), the other for medium to heavy stretch fabric (2).

					
①	②	3-5	1-2	3-5	D

Set up for blind hem

- Fold the fabric as illustrated. Make sure the folded edge of the fabric follows the inside of the right “toe” of Blind Hem Foot D.
- Lower the presser foot and step on the foot control.
- The left swing of the needle should just catch the edge of the folded fabric.
- If necessary, adjust the stitch width as needed to barely “catch” the fold.

Note: The blind hem technique is not recommended for light weight fabric.



Woven fabric

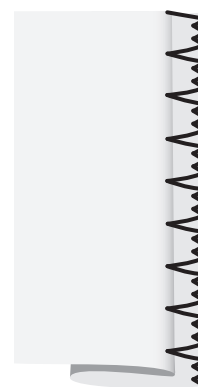

Stretch fabric

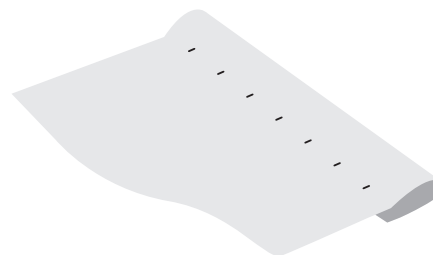

Right side of fabric

DARNING AND MENDING





Repair Large Holes

To cover large holes, it is necessary to sew a new piece of fabric onto the damaged area.





Baste the new piece of fabric onto the damaged area on the right side of the fabric.

Sew over the fabric edges with the zigzag or the multi-step zigzag stitch.

Trim the damaged area close to the seam from the wrong side of the fabric.

				
	4-6	2	3-5	A

Set up for zigzag

				
	5	1-2	3-5	B

Set up for multi-step zigzag

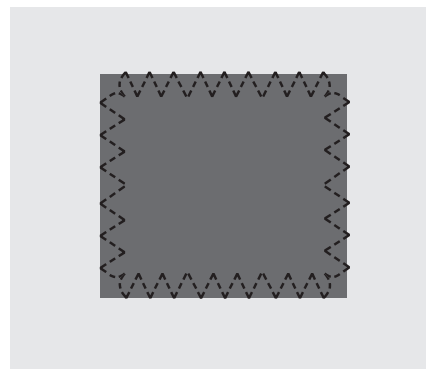

Repair Tears

On tears, frayed edges or small holes, it is useful to lay a piece of fabric on the wrong side of the fabric. The fabric underneath reinforces the damaged area.

Lay a piece of fabric underneath the damaged fabric. It must be a little larger than the damaged area.

Sew over the damaged area using the zigzag or multi-step zigzag stitch.

Trim the piece of fabric used as reinforcement.

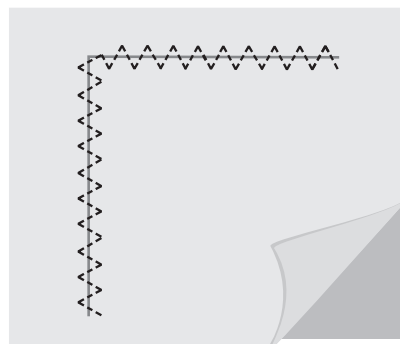

STANDARD BUTTONHOLE (MODEL ONYX 15)

The fabric should be interfaced and/or stabilized where buttonholes are to be sewn. It is suggested to hold fabric slightly when sewing buttonholes.





Prepare the Buttonhole

Measure diameter and thickness of the button and add 3mm (1/8") for bartacks to obtain correct buttonhole length. Mark the start position and buttonhole length on the fabric (A).

Attach the Buttonhole foot C.

Place the fabric under the foot, so that the marking on the buttonhole foot (B) aligns with start position (A) on fabric. Lower the foot, so that the buttonhole center line marked on the fabric aligns with the center of the buttonhole foot (B).

Sew the Buttonhole

1. Select stitch “” and sew the right side of the buttonhole to the required length.
2. Raise the needle to its highest position. Select stitch “” and sew a few bartacks.
3. Raise the needle to its highest position. Select stitch “” and sew the left side of the buttonhole until it matches the previous side in length.
4. Raise the needle to its highest position. Select stitch “” and sew a few bartacks.
5. To secure the buttonhole, thread the top thread into a needle, pull to the wrong side and tie the end before cutting excess thread.







Use seam ripper and cut the buttonhole open from both ends towards the middle.

The density of the buttonhole is adjusted with the Stitch Length Dial in the “”.

Note: Density varies according to the fabric. Always test sew a buttonhole on the fabric you are using to sew the buttonhole.

Tips:

- *Slightly reducing upper thread tension will produce better results.*
- *Use an extra stabilizer for fine or stretchy fabrics.*

  				
3	4	5	3-5	C

Set up for buttonhole

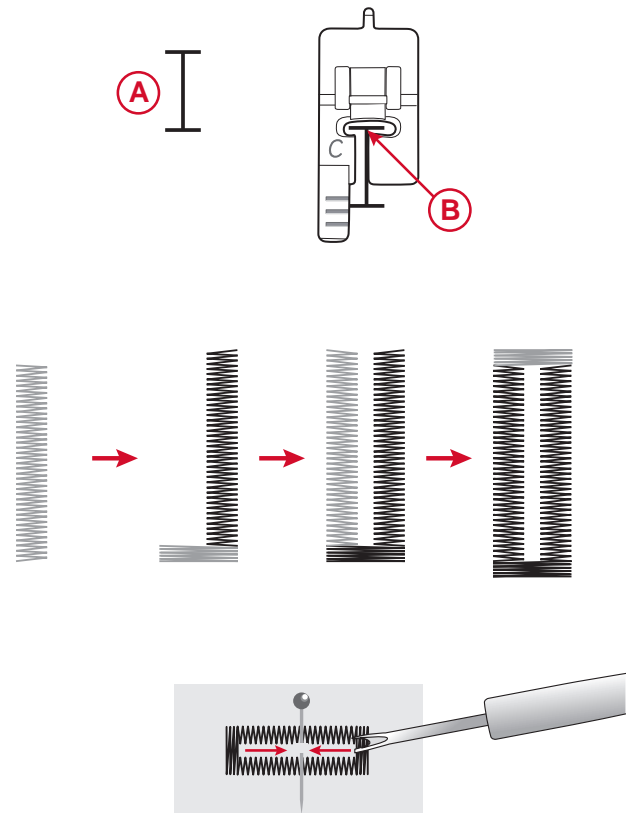







STANDARD BUTTONHOLE (MODEL ONYX 25)

Sew buttonholes perfectly sized for your button. The fabric should be interfaced and/or stabilized where buttonholes are to be sewn.

1. Mark the start position of the buttonhole on the fabric (A).
2. On the Buttonhole foot C, push the button holder open by pushing the lever backwards (B). Insert the button. Push the button holder forward until the button is locked in place (C). The button will determine the length of the buttonhole.
3. Attach the Buttonhole foot C.
4. Make sure that the thread is pulled through the hole in the presser foot and placed under the foot.
5. Position your fabric under the presser foot so that the marking on the fabric is aligned with the center of the Buttonhole Foot (D).
6. Lower the Buttonhole Lever and gently push it back (E).
7. Hold the end of the upper thread and start sewing. The buttonhole is sewn from the front of the presser foot to the back. Stop sewing when the buttonhole is finished (F).
8. Once the buttonhole is finished, raise the presser foot. Push the buttonhole lever all the way up.
9. To secure the bartack, thread the end of the top thread into a hand sewing needle, pull to the wrong side and tie the end before cutting excess thread.
10. Use a seam ripper and cut the buttonhole open from both ends towards the middle (G).

If you want to sew another buttonhole, do not push the buttonhole lever up when the buttonhole is finished. Instead, push it away from you again. Sew another buttonhole.

Note: Always sew a test buttonhole on a piece of scrap fabric.

				
	5		3-5	C

Set up for buttonhole

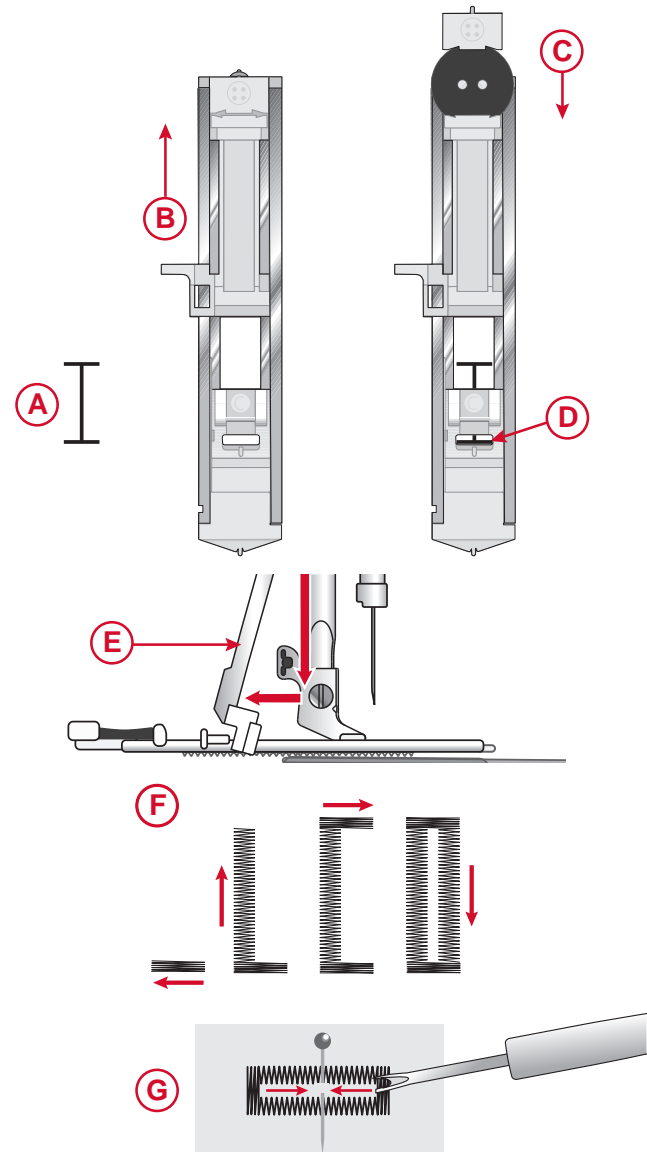





SEW ZIPPERS

The Zipper Foot can be attached on either the right or the left of the needle, making it easy to sew both sides of the zipper.

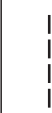
To sew the right side of the zipper, attach the foot in the left presser foot position (A).

To sew the left side of zipper, attach the foot in the right presser foot position (B).

				
	0	1.5-3	3-5	E

Set up for sewing zippers

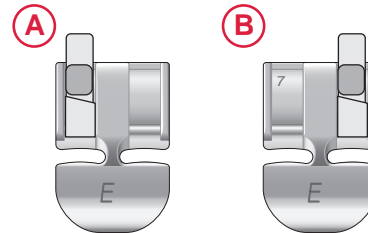

Centered Zipper

- Place the fabric pieces right sides together and pin. Mark the zipper length on your fabric.
- Baste the zipper seam using the specified seam allowance (use straight stitch with stitch length 4mm, thread tension 2). Baste to the end of zipper marking (C).
- Set up the machine for straight stitch (see table above), backstitch a few stitches and sew the rest of the seam using the specified seam allowance (C).
- Press the seam allowances open. Place the right side of the zipper to the wrong side of the seam, tape in place (D).
- Flip your project, making sure that the right side is facing up. Snap on the Zipper Foot, to the left side of the needle (A).
- Sew along the right side of the zipper to the end of your zipper, remember to backstitch in the beginning (E). Stop with the needle down in the fabric, lift the presser foot and turn your project to sew across the bottom of the zipper.
- Attach the Zipper Foot to the right side of the needle (B). Sew the remaining zipper side as you did with the first side (F).
- Flip your project to remove the tape on the back side.
- Flip your project to the right side again and remove the basting stitches.

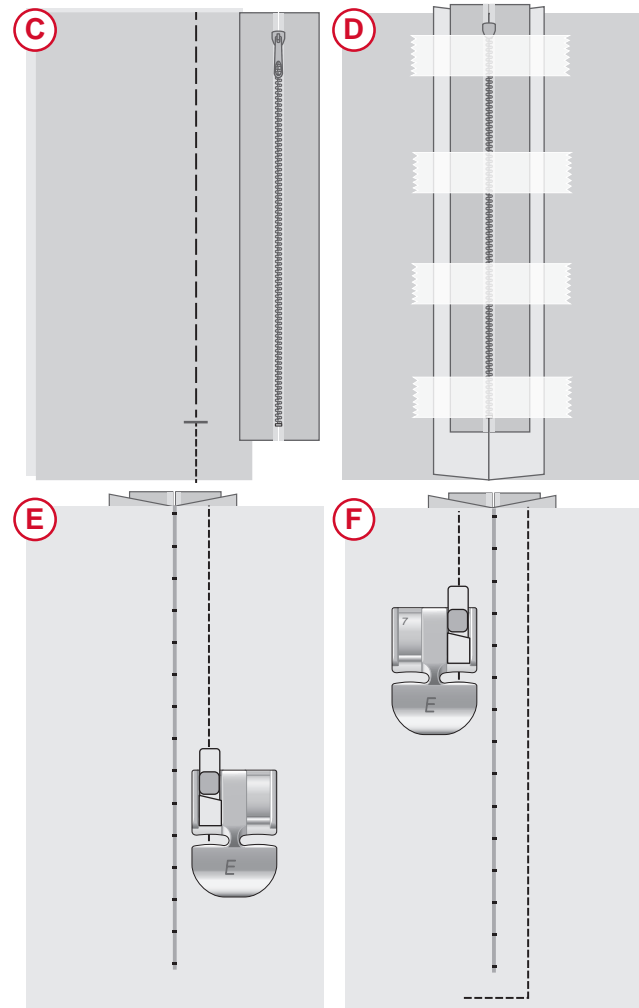

MAINTENANCE

CLEANING THE MACHINE EXTERIOR

To keep your sewing machine operating well, clean it often. No lubrication (oiling) is needed. Wipe the exterior surface of your machine with a soft cloth to remove any dust or lint built up.

REMOVING THE NEEDLE PLATE AND CLEANING THE BOBBIN AREA

 *Raise the needle and turn off the machine.*

Remove the presser foot. Slide off the bobbin cover and remove the bobbin.

Remove the screws in the needle plate by using the screwdriver. Lift up and remove the needle plate.

Clean the feed teeth and the bobbin area with the brush found among the accessories.

Place the needle plate over the feed teeth, replace and tighten the screws.

Attach the presser foot, insert the bobbin and replace the bobbin cover.

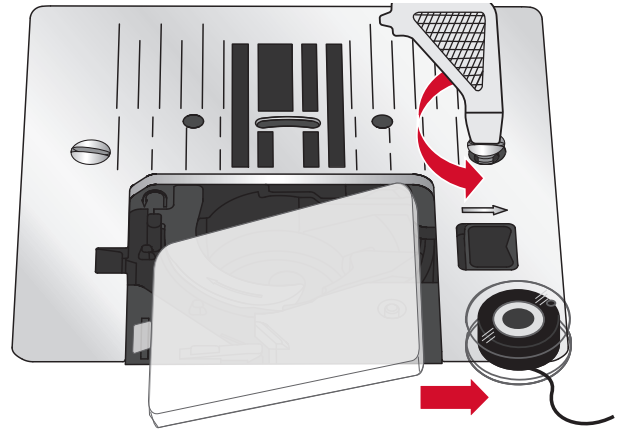

CLEANING UNDER THE BOBBIN AREA

 *Raise the needle and turn off the machine.*

Clean the area under the bobbin case after sewing several projects or any time you notice an accumulation of lint in the bobbin case area.

Remove the presser foot. Slide off the bobbin cover and remove the bobbin.

Remove the screws in the needle plate by using the L-screwdriver. Lift up and remove the needle plate.

Clean the area with the brush or with a dry cloth.

Note: Do not blow air into the bobbin case area. The dust and lint will be blown into your machine.

Guide the “forked” end of the bobbin case (A) under the bobbin case holder (B) and under the feed teeth. Move the bobbin case slightly from right to left until it slips correctly into the hook race (C). To make sure the bobbin case is properly replaced, turn the handwheel towards you. The hook race (C) should rotate freely in a counter-clockwise direction.

Place the needle plate over the feed teeth, replace and tighten the screws.

Attach the presser foot, insert the bobbin and replace the bobbin cover.

Note: Regularly clean the lint and threads from the bobbin area. Check the area when changing the needle plate.

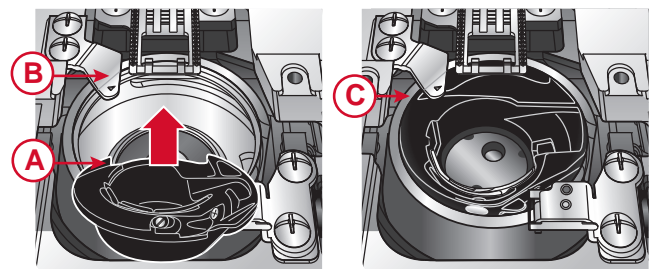
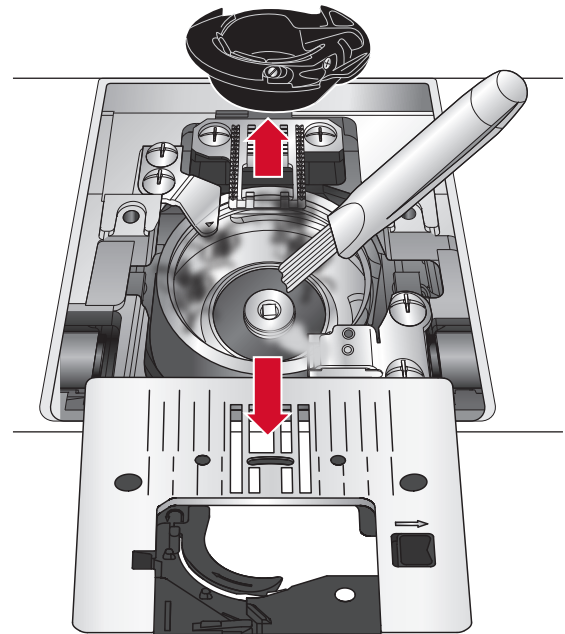

TROUBLESHOOTING

In this troubleshooting guide you will find solutions to the problems you may have with your machine. For further information please contact your local authorized HUSQVARNA® VIKING® retailer who will be happy to help you.

Thread Loops on Underside of Fabric

Possible cause: Thread looping on the underside of the fabric is always an indication that the upper thread is not correctly threaded. This happens when the upper thread is not correctly placed in the thread tension mechanism and has not been threaded through the take up lever.

Solution: Rethread the machine, making sure to first raise the presser foot lifter before starting to thread, so thread can be properly seated in the tension mechanism and take up lever. To know if you have rethreaded the machine correctly, try this test:

- Raise the presser foot lifter and thread the top of the machine.
- Thread the needle, but don't put the thread under the presser foot yet. As you pull the upper thread to the left, it should pull freely.
- Put the presser foot lifter down. As you pull the upper thread to the left, you should feel resistance. This means you are threaded correctly.
- Put the thread under the presser foot, and then draw up the bobbin thread. Slip both thread tails under the presser foot towards the back. Lower the presser foot and begin sewing.

If you put the presser foot lifter down, but the thread still pulls freely (you feel no difference whether the presser foot is up or down), this means that you have threaded incorrectly. Remove the upper thread and rethread the machine.

Bobbin Thread Breaking

Possible cause: Bobbin is threaded incorrectly.

Solution: Check that bobbin is placed correctly in the bobbin holder.

Possible cause: Bobbin wound too full or unevenly.

Solution: Bobbin thread may not have been correctly placed into bobbin winding tension disc during the bobbin winding process.

Possible cause: Dirt or lint in bobbin holder.

Solution: Clean bobbin holder.

Possible cause: Wrong bobbins being used.

Solution: Use bobbins that are the same style as those that come with the machine – don't substitute.

Bobbin Thread Showing on Top of Fabric

Possible cause: Top thread is too tight.

Solution: Reduce upper thread tension.

Possible cause: Thread path is obstructed, putting extra tension on top thread.

Solution: Check that the top thread path is not obstructed and thread is moving freely through the thread path.

Possible cause: Bobbin thread not in bobbin case tension.

Solution: Rethread bobbin.

Bobbin Winding Difficulties

Possible cause: Bobbin thread loosely wound on bobbin.

Solution: Rewind bobbin, making sure that the thread is placed snugly in the bobbin winding tension disc.

Possible cause: Bobbin winding spindle not fully engaged, therefore bobbin not winding.

Solution: Check that the bobbin winding spindle has been fully engaged before starting to wind.

Possible cause: Bobbin is winding sloppily because thread end not held at beginning of winding process.

Solution: Before starting to wind, hold the thread tail (coming out of the bobbin) securely, allow the bobbin to partially fill, then stop to trim the thread tail close to the bobbin.

Fabric Puckers

Possible cause: Top thread is too tight.

Solution: Reduce top thread tension.

Possible cause: Stitch length is set too short.

Solution: Increase stitch length setting.

Possible cause: Wrong style needle for fabric type.

Solution: Use correct needle style and size for your fabric.

Fabric Is Tunneling Under Stitches

Possible cause: Fabric is not properly stabilized for the density of the stitches (for example, satin stitch applique).

Solution: Add a fabric stabilizer underneath the fabric to help keep the stitches from tunneling in together, forming a puckered ridge in fabric.

Loud Noise When Sewing

Possible cause: Thread not in take-up lever.

Solution: Retread the machine, making sure the take up lever is in its highest position so thread goes in the eye of the take up lever — turn machine hand wheel toward you to raise the take up lever to its highest position for threading.

Possible cause: Thread path is obstructed.

Solution: Check that thread is not caught on the thread spool or behind the spool cap.

Machine is Not Feeding Fabric

Possible cause: Presser foot lifter has not been lowered onto fabric after threading.

Solution: Lower the presser foot lifter before starting to sew. Don't "push" or "pull" the fabric as you sew.

Possible cause: Feed teeth lever may have been returned to "up" position, but the handwheel has not yet been turned one full turn to completely re-engage the feed teeth.

Solution: The feed teeth need to be raised and re-engaged by turning the handwheel one full revolution.

Possible cause: Stitch length is set at zero.

Solution: Increase stitch length setting.

Machine Will Not Sew

Possible cause: Bobbin winding spindle is engaged when you try to sew.

Solution: Disengage bobbin winding spindle by pushing it to the left.

Possible cause: Power cord and/or foot control not plugged in correctly.

Solution: Make sure power cord/foot control are correctly seated in machine and power supply.

Possible cause: Wrong bobbins being used.

Solution: Use bobbins that are the same style as those that come with the machine — don't substitute.

The Needles Breaks

Possible cause: Bent, dull or damaged needle.

Solution: Discard needle, insert new needle.

Possible cause: Wrong size needle for fabric.

Solution: Insert appropriate needle for fabric type.

Possible cause: Machine not threaded correctly.

Solution: Rethread the machine completely.

Possible cause: “Pushing” or “pulling” fabric.

Solution: Don't manually push/pull fabric in order to sew, but allow the machine's feed teeth to draw fabric under the presser foot as you guide it.

Needle Threader Not Working

Possible cause: Needle not in correct position.

Solution: Raise needle to its highest position by turning hand wheel toward you.

Possible cause: Needle inserted incorrectly.

Solution: Position needle all the way up in the needle clamp.

Possible cause: Needle is bent.

Solution: Remove the bent needle, insert new needle.

Possible cause: Hook pin damaged.

Solution: Needle Threader needs replacement. Contact authorized service center.

Skipping Stitches

Possible cause: Needle inserted incorrectly.

Solution: Check that flat side of needle top is toward back of machine and needle is up as far as it can go, then tighten needle clamp screw.

Possible cause: Wrong needle for fabric sewn.

Solution: Use correct needle style and size for your fabric.

Possible cause: Bent, dull or damaged needle.

Solution: Discard needle and insert new needle.

Stitches Distorted

Possible cause: “Pushing” or “pulling” the fabric.

Solution: Don't manually push/pull fabric in order to sew, but allow the machine's feed teeth to draw fabric under presser foot as you guide it.

Possible cause: Incorrect stitch length setting.

Solution: Adjust stitch length setting.

Possible cause: Stabilizer may be needed for technique.

Solution: Place stabilizer underneath fabric.

Thread Bunching at Beginning

Possible cause: Top and bobbin threads have not been properly placed underneath presser foot before starting to sew.

Solution: *Ensure that both the top thread and the bobbin thread are under the presser foot and toward the back before starting to sew.*

Possible cause: Sewing was started with no fabric under the presser foot.

Solution: *Place fabric under foot, making sure that needle comes down into fabric; lightly hold both thread tails for first few stitches.*

Possible cause: Stabilizer may be needed for technique.

Solution: *Place stabilizer underneath fabric.*

Upper Thread Breaking

Possible cause: Thread path obstructed.

Solution: *Check if thread is caught on thread spool (rough spots on the spool itself) or behind spool pin or spool cap (if the thread has fallen behind the spool cap and therefore cannot feed freely through the machine path).*

Possible cause: Machine is not threaded correctly.

Solution: *Remove upper thread completely, raise presser foot lifter, rethread machine making sure thread is in take-up lever (raise take-up lever to its highest position by turning hand wheel toward you).*

Possible cause: Upper tension too tight.

Solution: *Reduce upper thread tension.*

Technical Specification

Household Sewing Machine

Sewing Speed 750 ± 50rpm	Rated Voltage 240 V/50Hz, 230 V/50Hz, 220 V/50-60Hz, 127 V/60 Hz, 120 V/60 Hz, 100V/50-60Hz	Presser Foot Rise Height 6.5mm
Protection class: II (Europe)	Stitch Width 0-5.0mm (model Onyx 15) 0-6.0mm (model Onyx 25)	Stitch Length 0-4.0mm (model Onyx 15) 0-4.0mm (model Onyx 25)
Light LED Light	Nominal Consumption 70W	Net Weight Machine only 5.9kg (model Onyx 15) 6.1kg (model Onyx 25)
Machine Dimensions Length: ≈45cm Width: ≈20cm Height: ≈28cm	Foot Control FC-2902D (220-240V) manufactured by Zhejiang Founder Motor Corporation, LTD. (Vietnam) / 4C-326G (230V) / 4C-336G (240V) manufactured by Wakaho Electric Ind. Co., Ltd. (Vietnam). FC-1902 (110-120V area)KD-1902(100V)manufactured by ZHEJIANG FOUNDER MOTOR CORPORATION LTD. (China) / 4C-326C (220V) 4C-316B (110-125V area) 4C-316C (127V)manufactured by Wakaho Electric Ind. Co., Ltd. (Vietnam).	

The technical specifications and this user's guide can be changed without prior notice.