

Instruction Book

2000CPX

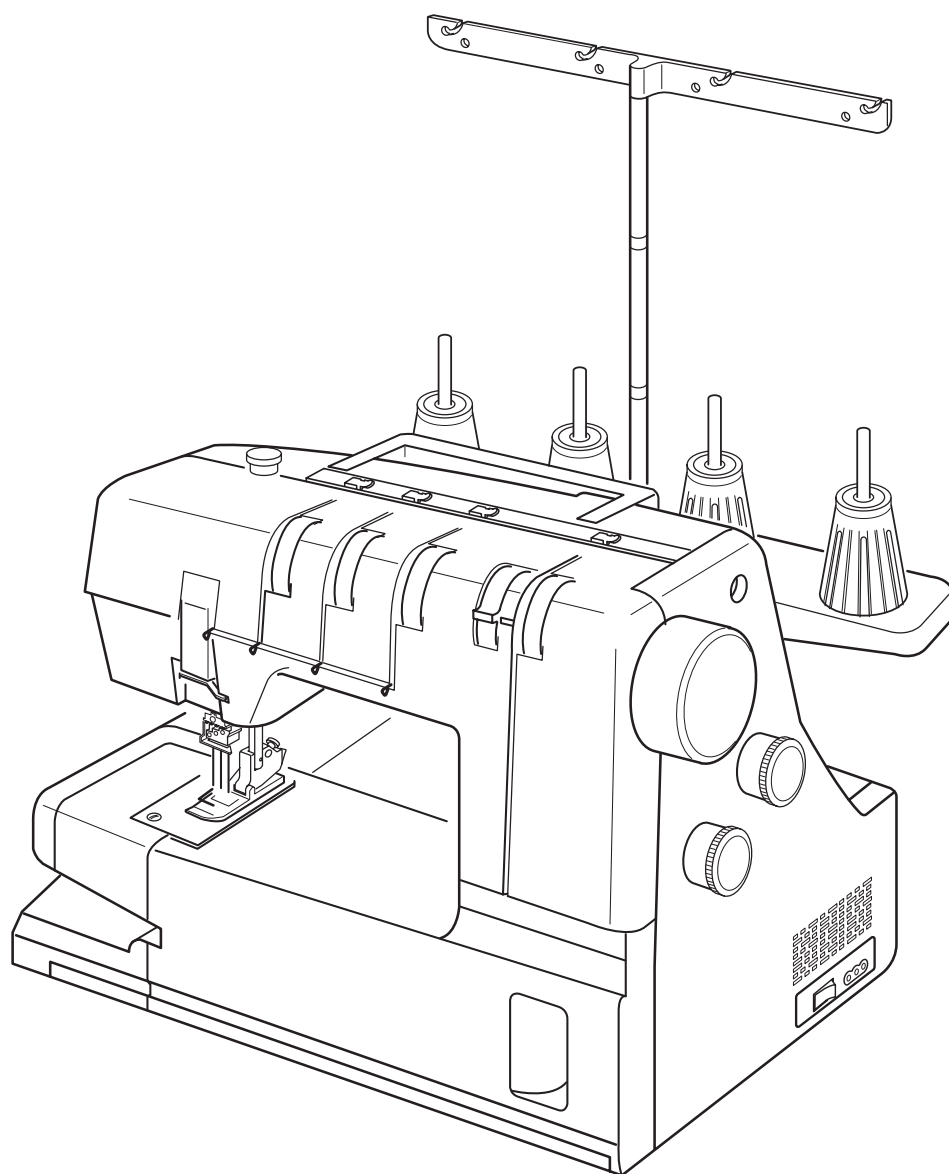

TABLE OF CONTENTS

KNOW YOUR MACHINE

Names of Parts	2
Standard Accessories	4

GETTING READY TO SEW

Connecting the Machine to the Power Supply	6
Controlling Sewing Speed	6
How to Turn the Handwheel	8
Opening and Closing the Looper Cover	8
Extension Table	8
Raising or Lowering the Presser Foot	10
Removing the Presser Foot	10
Attaching the Presser Foot	10
Adjustment of Foot Pressure	10
Adjustment of Stitch Length	12
Adjustment of Differential Feed Ratio	12
Changing Needle	14
How to use the needle threader/holder	14
Setting the Thread Guide Bar	16
Setting the Spool Cones	16
Threading the Machine	18
Threading the needles	20
How to use the threader	22
Threading the looper	24

STITCH TYPES

Triple Cover Stitch	28
Balancing the thread tension	28
Cover Stitch	30
Balancing the thread tension	32
Chain Stitch	34
Balancing the thread tension	34
Curling Problem	36
Finishing the Seam	38
Beginning of the seam	38
End of the seam	38
Knotting the threads	38
Removing the Fabric in the Middle of the Stitching	40
Hemming with the Cover Stitch	42
Free Arm Hemming	42
Triple Cover Stitch Applications	44

CARE OF YOUR MACHINE

Cleaning the Feed Dogs and Looper Area	46
Troubleshooting	48

KNOW YOUR MACHINE

Names of Parts

- ① Differential feed dial
- ② Stitch length dial
- ③ Handwheel
- ④ Spool stand
- ⑤ Spool holder
- ⑥ Spool pin
- ⑦ Thread guide bar
- ⑧ Thread guide post
- ⑨ Looper thread tension dial
- ⑩ Looper thread tension switching lever
- ⑪ Thread guide plate
- ⑫ Carrying handle
- ⑬ Right needle thread tension dial
- ⑭ Pressure adjusting screw
- ⑮ Center needle thread tension dial
- ⑯ Left needle thread tension dial
- ⑰ Looper
- ⑱ Looper release knob
- ⑲ Looper thread take-up lever
- ⑳ Looper cover
- ㉑ Power switch
- ㉒ Machine socket
- ㉓ Presser foot lifter
- ㉔ Presser foot holder
- ㉕ Thread cutter
- ㉖ Extension table
- ㉗ Needle plate
- ㉘ Attachment mount
- ㉙ Presser foot
- ㉚ Left needle (#80/12)
- ㉛ Center needle (#80/12)
- ㉜ Right needle (#80/12)
- ㉝ Feed dogs

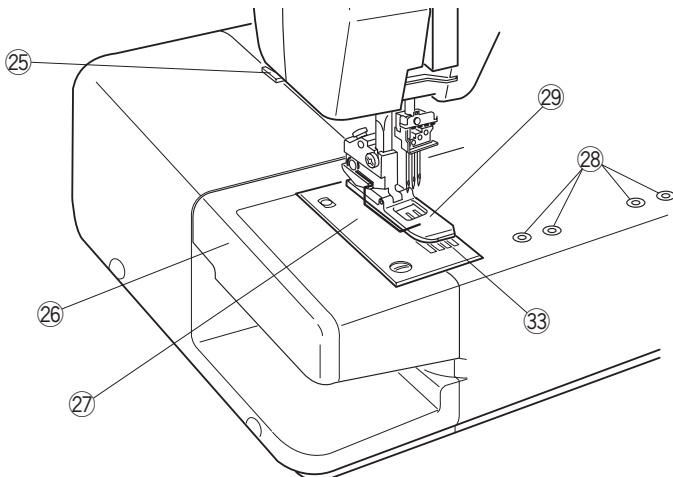
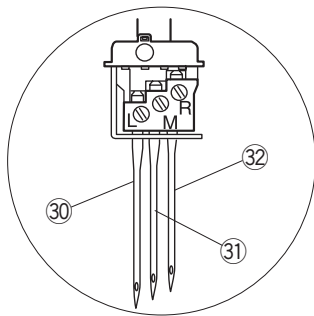
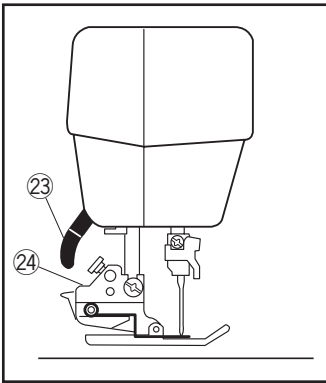
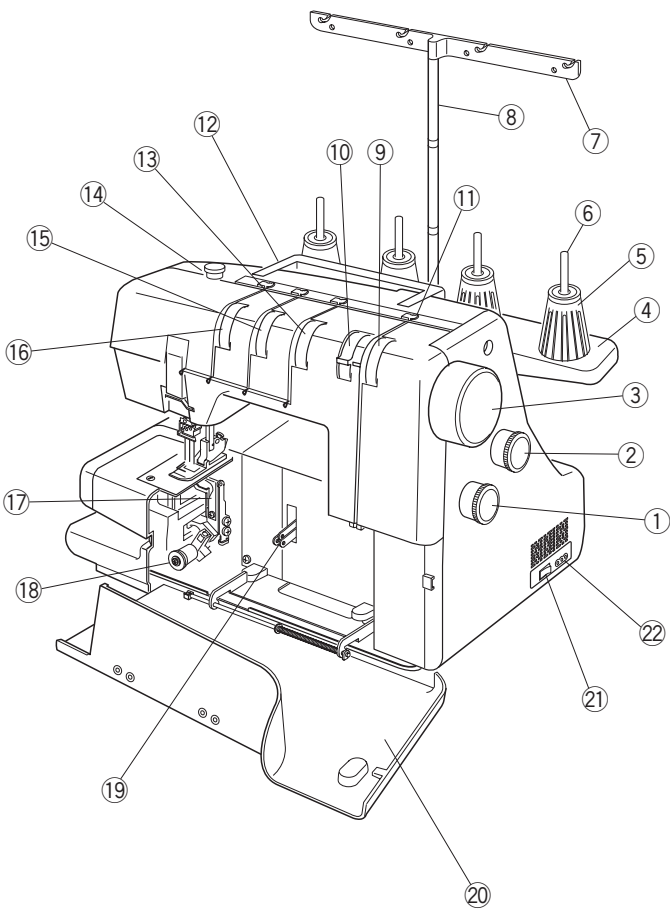

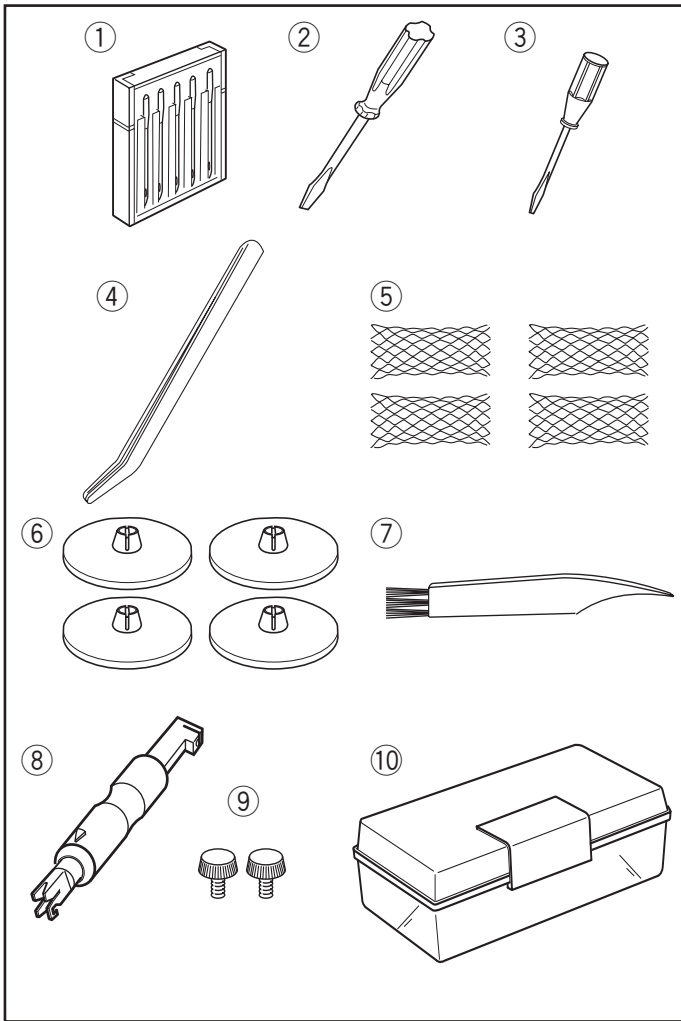

Standard Accessories

- ① Set of needles: 2 X #80/12, 3 X #90/14
(Schmetz EL X 705)
- ② Screwdriver (Large)
- ③ Screwdriver (Small)
- ④ Tweezers
- ⑤ Nets
- ⑥ Spool holder caps
- ⑦ Lint brush
- ⑧ Needle threader
- ⑨ Attachment screws (for fixing optional accessories)
(Refer to the instruction sheet of the optional
accessory)
- ⑩ Accessory box

GETTING READY TO SEW

Connecting the Machine to the Power Supply

- 1 Turn off the power switch, and connect the machine plug to the machine socket.
- 2 Connect the power supply plug to your power supply.
- 3 Turn on the power switch.

- ① Power switch
- ② Machine plug
- ③ Machine socket
- ④ Power supply plug
- ⑤ Power supply
- ⑥ Foot control

Controlling Sewing Speed

Sewing speed can be varied by the foot control.

The harder you press on the control, the faster the machine runs.

Step on the foot control with the presser foot lifter up, and practice controlling the speed.

- ① Foot control

For Your Safety:

- * While the machine is in operation, always keep your eyes on the sewing area, and do not touch any moving parts such as the thread take-up lever, loopers, handwheel or needles.
- * Always disconnect the machine from the power supply:
 - when leaving the machine unattended.
 - when attaching or removing parts.
 - when threading or cleaning the machine.
- * Do not place anything on the foot control, except when the machine is in use.

Operating instruction:

- The symbol “O” of a switch indicates the “off” position of a switch.
- Foot controller Model YC-482J-1 is for use with this sewing machine (U.S.A. and Canada only).

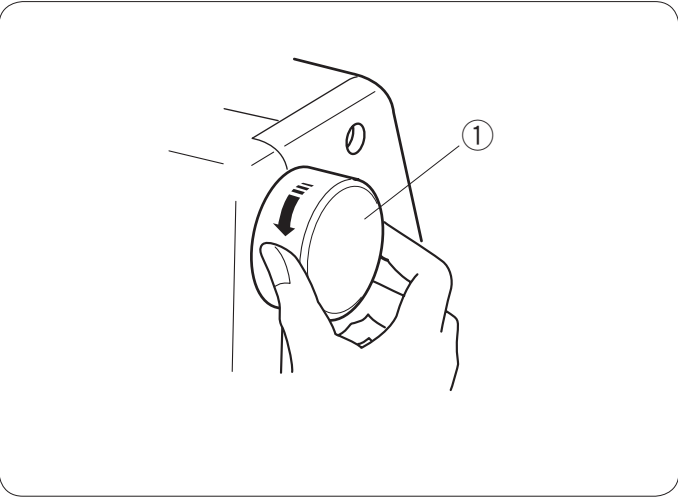

How to Turn the Handwheel

Always turn the handwheel toward you (counterclockwise).

- ① Handwheel

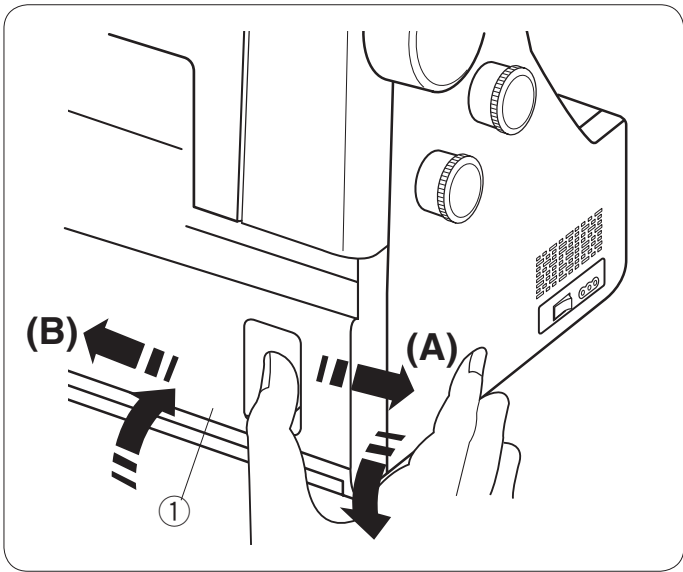

Opening and Closing the Looper Cover

To open: (A)

While pushing with the thumb to the right as far as it will go, pull the looper cover toward you.

To close: (B)

Lift the looper cover and push it against the machine. The looper cover snaps into its position automatically.

- ① Looper cover

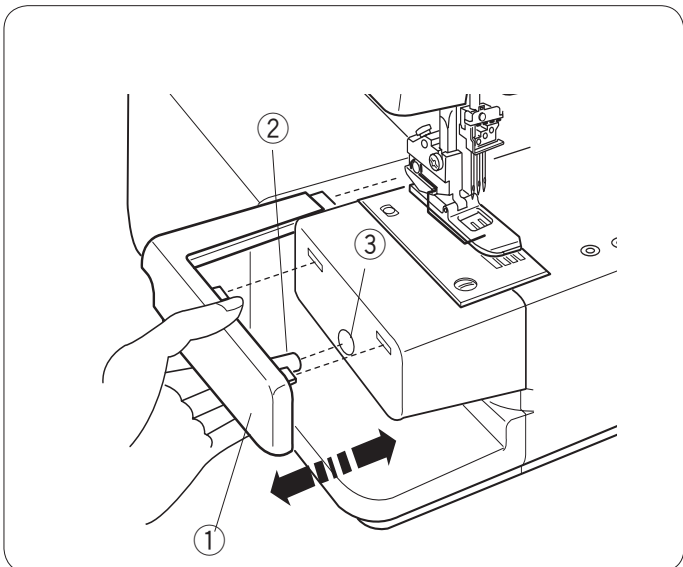

Extension Table

The extension table provides added sewing surface and can be easily removed for free arm sewing.

Detaching the table:

Pull the table away from the machine.

- ① Extension table

Attaching the table:

Align the pin on the table with the hole in the machine. Push the extension table until it snaps into the machine.

- ② Pin
- ③ Hole

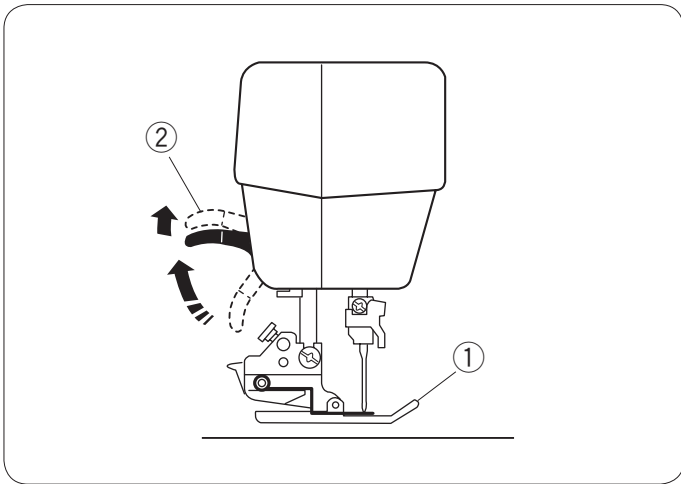

Raising or Lowering the Presser Foot

By raising or lowering the presser foot lifter, the presser foot goes up or down.

* While in operation, keep the presser foot lowered except when threading the machine or test running without threads.

NOTE:

Thread tension will be released when the presser foot lifter is raised.

- ① Presser foot
- ② Presser foot lifter

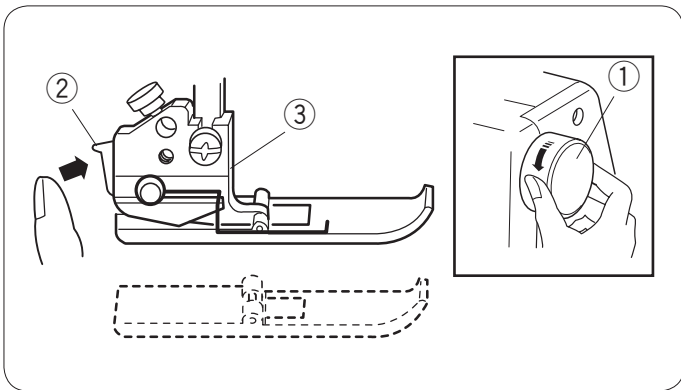

Removing the Presser Foot

- 1 Turn off the power switch and unplug the machine.
- 2 Turn the handwheel toward you to raise the needle. Raise the presser foot.
- 3 Press the lever located on the back of the foot holder. The presser foot will drop off.

- ① Handwheel
- ② Lever
- ③ Foot holder

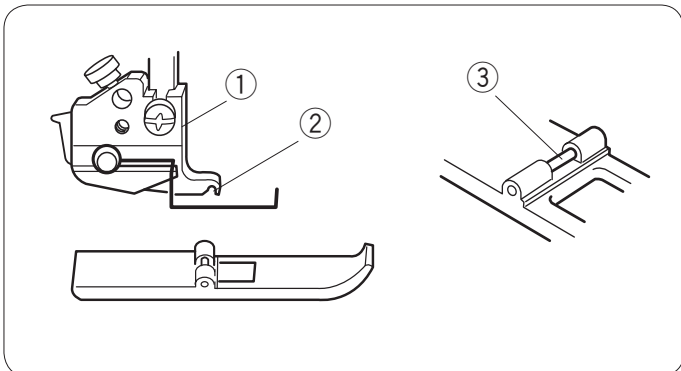

Attaching the Presser Foot

- 1 Turn off the power switch and unplug the machine.
- 2 Place the presser foot so that the pin on the foot lies just under the groove of the foot holder.
- 3 Lower the foot holder to lock the foot into place.
- 4 Raise the presser foot lifter to check that the presser foot is secure.

- ① Foot holder
- ② Groove
- ③ Pin

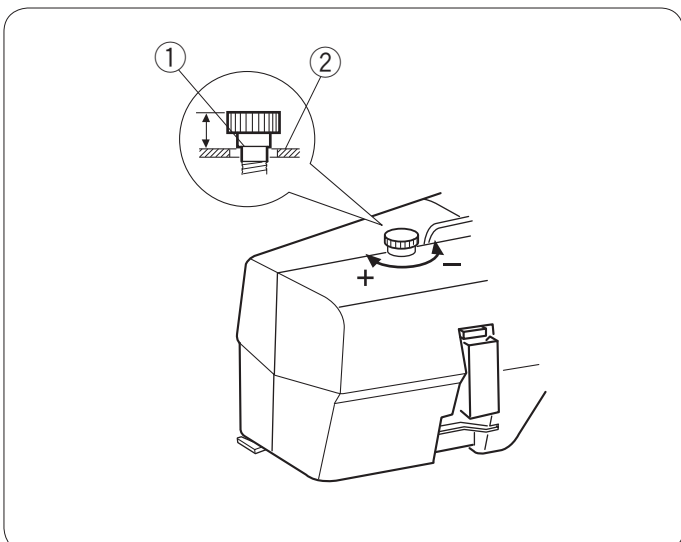

Adjusting the Foot Pressure

It is not necessary to adjust the pressure of the presser foot for regular sewing.

When sewing heavyweight fabrics, increase the foot pressure by turning the adjusting screw in the direction of "+".

When sewing lightweight fabrics, decrease the foot pressure by turning the adjusting screw in the direction of "-".

For regular sewing, align the line on the screw with the top surface of the machine.

- ① Line
- ② Top surface

Adjustment of Stitch Length

To adjust the stitch length, turn the dial.
The larger the number, the longer the stitch.

For regular sewing, set the stitch length at 3 – 3.5.

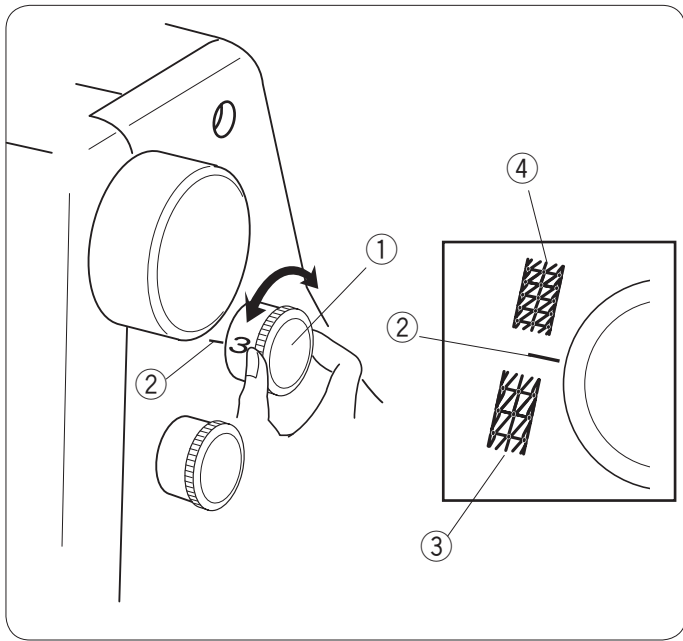

- ① Stitch length dial
- ② Setting mark
- ③ To lengthen
- ④ To shorten

Adjustment of Differential Feed Ratio

The differential feed ratio can be altered by turning the dial.

The number on the dial indicates the ratio between the main and the sub feed motion.

- Set the dial at 1.0 for regular sewing.
- Set the dial at a lower number when sewing fine fabrics that tend to pucker.
- Set the dial at a higher number when sewing stretch fabrics such as knits, jersey and tricot.

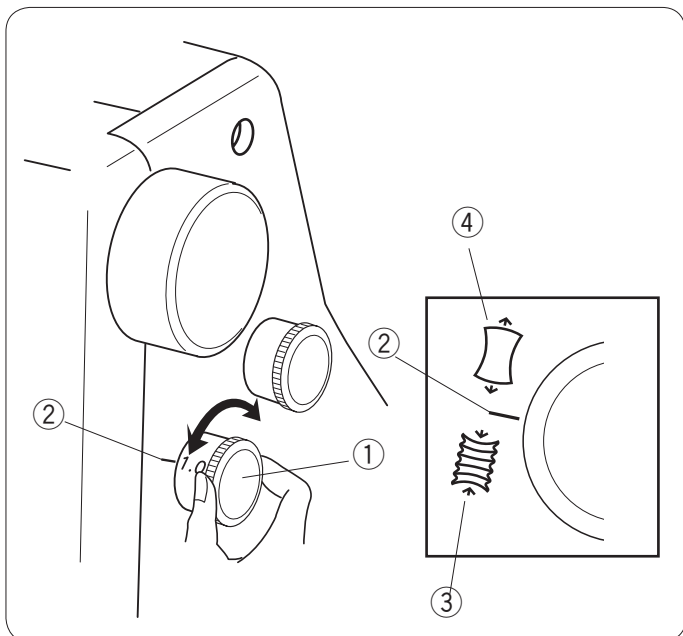

- ① Differential feed dial
- ② Setting mark
- ③ To shrink
- ④ Changing Needle

Changing Needle



WARNING:

Turn the power switch off and unplug the machine before changing needles.

Turn the handwheel toward you to raise the needle to its highest position.

- ① Handwheel

Then loosen the needle clamp screw for the needle you are going to remove.

- ② Needle clamp screw
- ③ Small screwdriver

Insert a new needle into the needle clamp with the flat side to the back and push it up against the stopper, then tighten the needle clamp screw.

- ④ Flat side
- ⑤ Stopper

How to use the needle threader/holder

To attach the needle easily, use the end of the needle threader to hold the needle.

Insert a needle into the needle threader/holder with the flat side facing back as shown.

Hold the stem and insert the needle into the needle clamp and push it up as far as it will go.

Tighten the needle clamp screw firmly while supporting the holder in place.

Pull the holder down to remove it.

- ⑥ Needle threader/holder

NOTES:

Use Organ needles EL X 705 size 80/12 or EL X 705 size 90/14.

Do not use any needle which is bent or blunt.

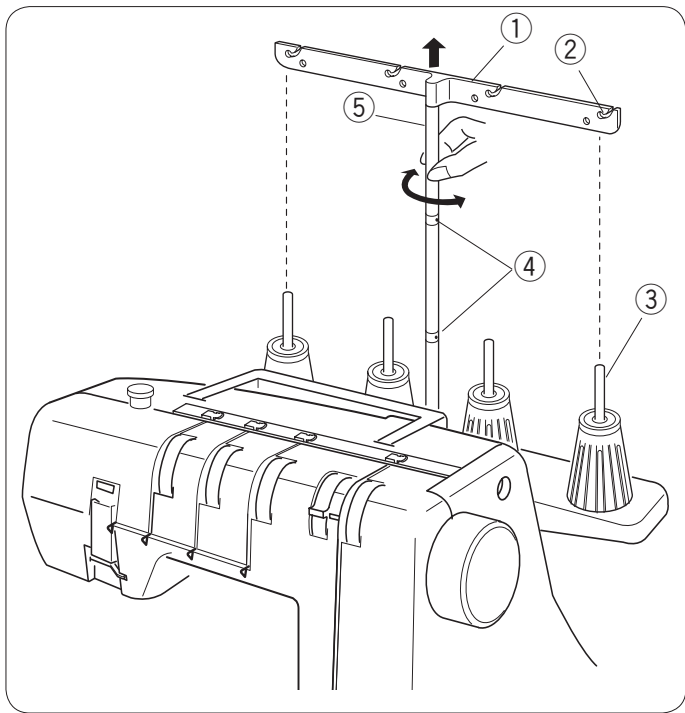

Setting the Thread Guide Bar

Pull the thread guide bar up as far as it will go.

Turn the thread guide bar so that the thread guides are right above the spool pins.

- ① Thread guide bar
- ② Thread guide
- ③ Spool pin
- ④ Stoppers
- ⑤ Thread guide post

NOTE:

Make sure the two stoppers on the thread guide post, as shown, are set in at the correct position.

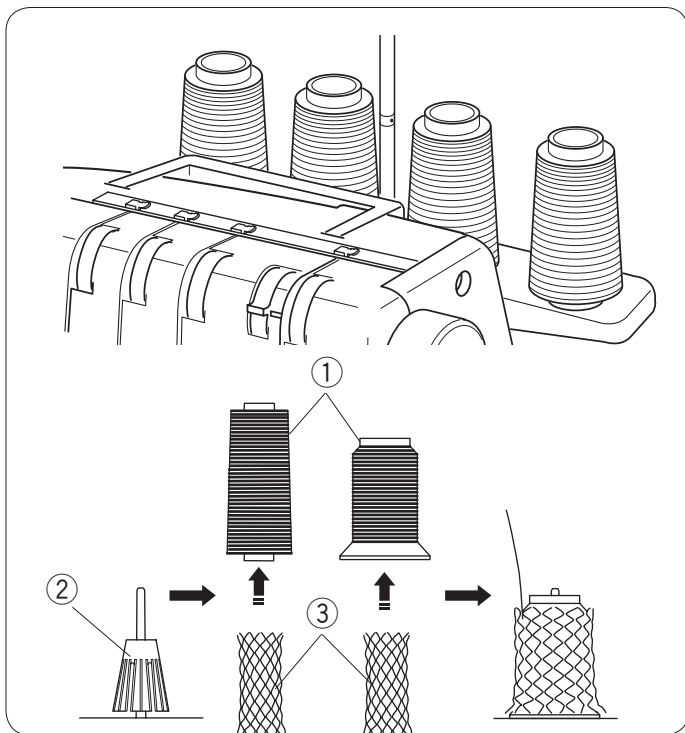

Setting the Spool Cones

Place the spool cones on the spool holders. Thread the machine in the following order:

If the thread slips down from a spool cone during threading and/or sewing, put a net over the spool cone as illustrated to prevent jamming.

- ① Spool cone
- ② Spool holder
- ③ Net

When using small spools, remove the spool holders from the spool pins.

- ④ Small spool of thread
- ⑤ Spool pin

Place the spool with its slit side up, and put the spool holder cap on top of it.

- ⑥ Spool holder cap

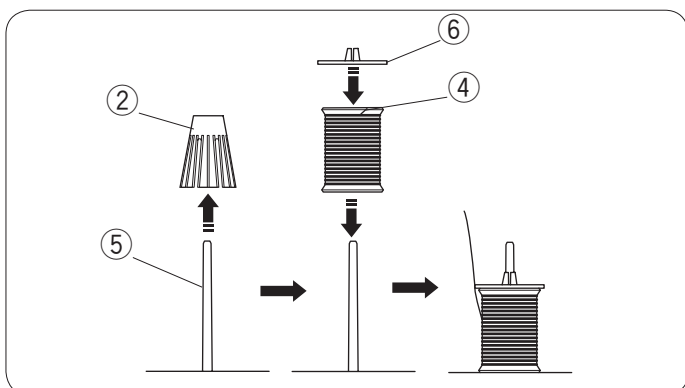

Threading the Machine



WARNING:

Turn the power switch off and unplug the machine before threading the machine.

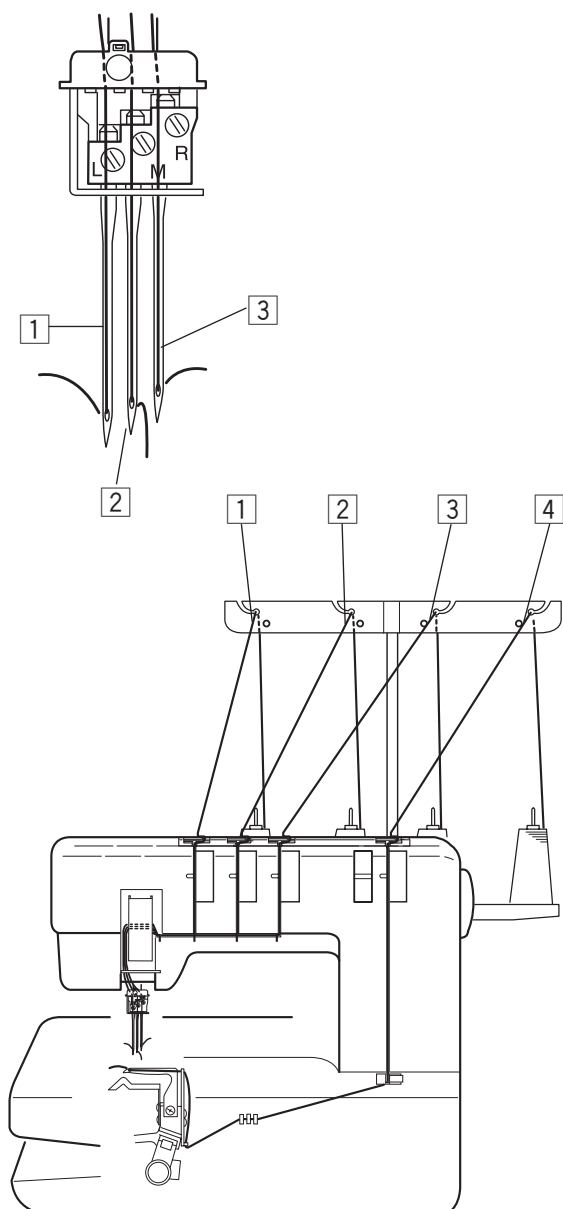

- 1 Left needle thread
- 2 Center needle thread
- 3 Right needle thread
- 4 Looper thread

Raise the presser foot lifter.

- ① Presser foot lifter

NOTE:

When threading the machine always raise the presser foot.

Turn the handwheel toward you to bring the needles to their highest position.

- ② Handwheel

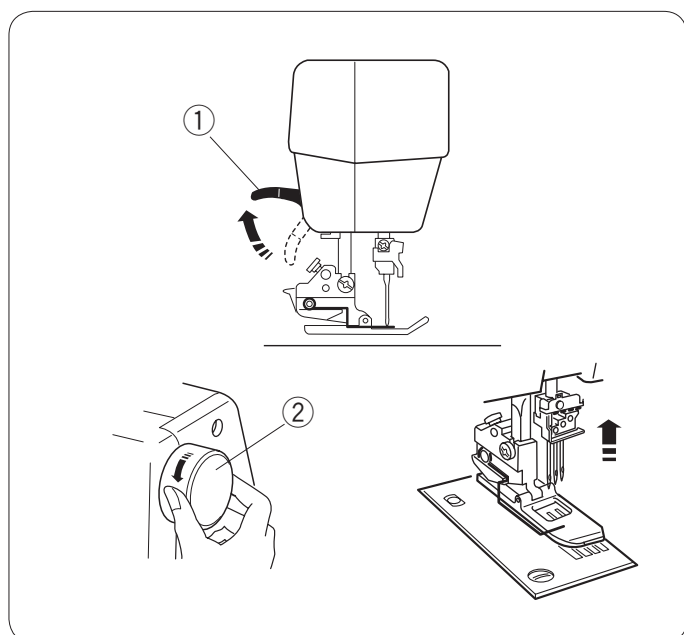

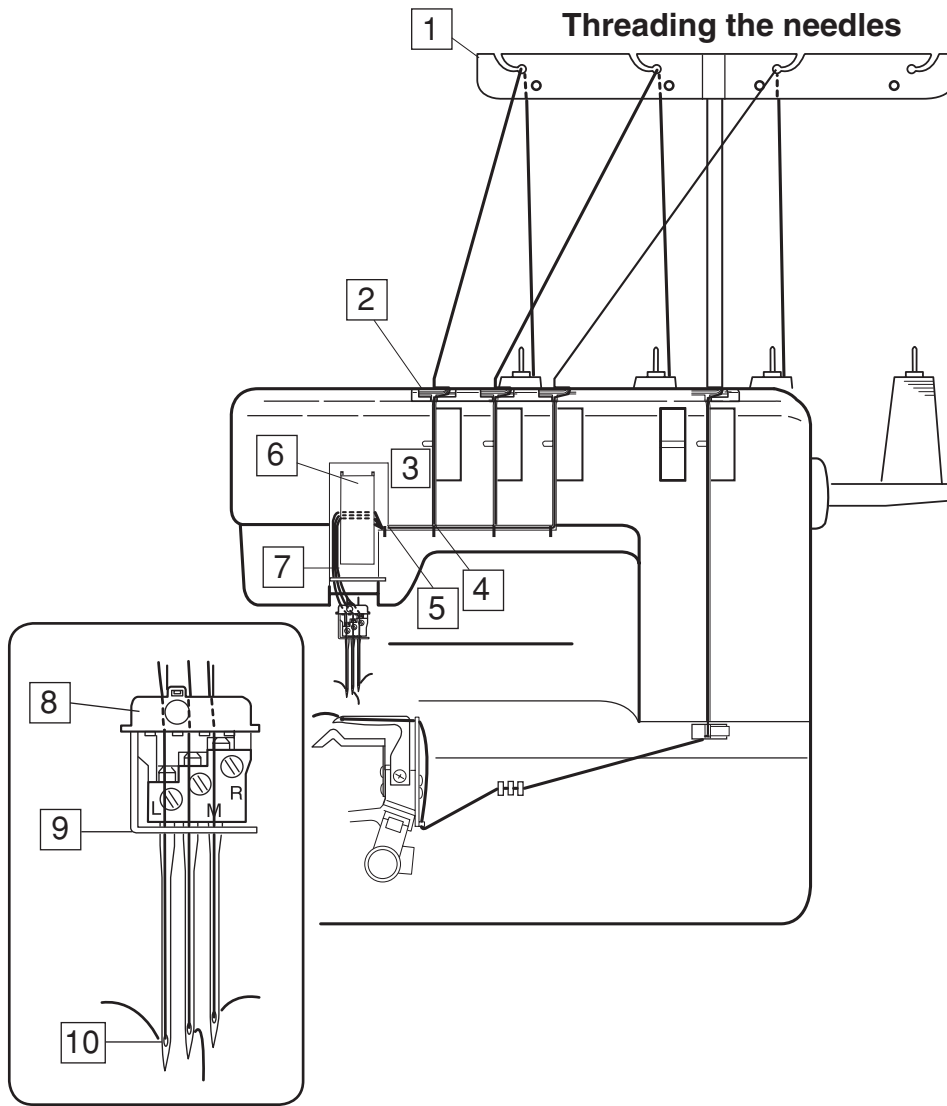

Thread each needle in the following steps:

- 1 Draw the thread through the left side thread guide bar from back to front as shown (A).

NOTE:
If the thread is coming out from the thread guide notch, pass the thread through the thread guide hole again as shown (B)

- ① Thread guide bar

- 2 Slip the thread into the thread guide plate on the machine as shown.

- ② Thread guide plate

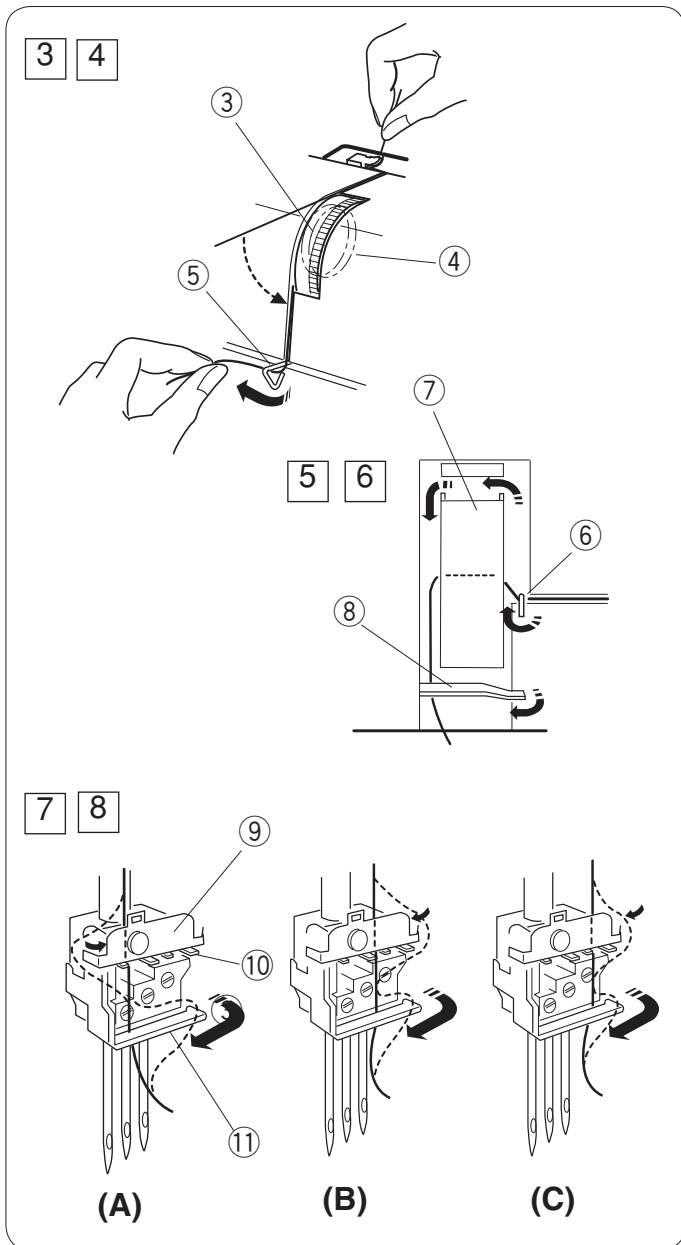

- 3 Hold the thread at both ends and tug gently to ensure the thread is correctly inserted between the tension disks. (If the presser foot lifter is raised, the thread easily inserts between the tension discs.)
 - 3 Tension dial
 - 4 Tension disks
- 4 Pass the thread through the thread guide (A) from the right.
 - 5 Thread guide (A)
- 5 Draw the thread to the left and pass it through the thread guide (B). Draw the thread up and slip it behind the take-up lever cover.
 - 6 Thread guide (B)
 - 7 Take-up lever cover
- 6 Pull the thread down and slip it behind the thread guide (C) from the right.
 - 8 Thread guide (C)
- 7 Thread each needle as follows:

Left Needle (A): Pass the thread behind the thread guide plate from the left. Pass the thread between the first and second prongs from the left.

Center needle (B): Pass the thread behind the thread guide plate from the right. Pass the thread between two inner prongs.

Right needle (C): Pass the thread behind the thread guide plate from the right. Pass the thread between the first and second prongs from the right.

 - 9 Thread guide plate
 - 10 Prongs
- 8 Slip all the threads behind the needle bar thread guide from the right. Thread each needle with the threader (see below).
 - 11 Needle bar thread guide

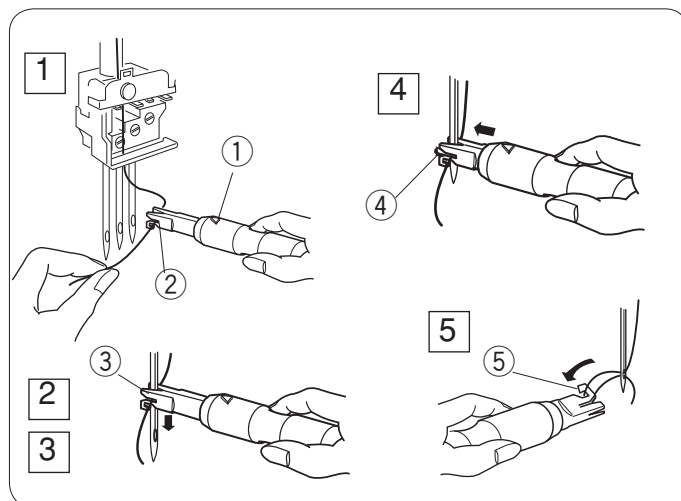

How to use the threader

- 1 Hold the grip of the threader with the triangle mark up. Insert the thread into the slit of the Y-shaped notch.
 - 1 Triangle mark
 - 2 Y-shaped notch
- 2 Place the V-shaped notch over the needle just above the needle eye.
- 3 Slide the threader down along the needle while pushing it against the needle, until the threader pin enters into the needle eye.
 - 3 V-shaped notch
 - 4 Threader pin
- 4 Push the threader and the thread will go through the needle eye.
- 5 Remove the threader from the needle. Then pick up the loop of the thread with the hook. Pull the thread end out to the back.
 - 5 Hook

Threading the looper

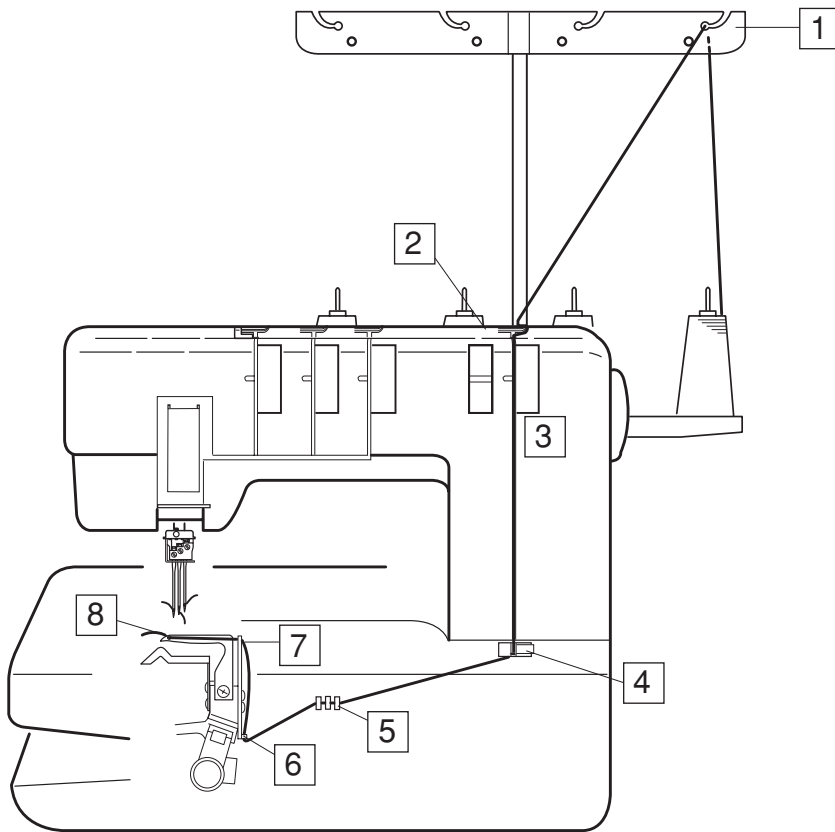

Thread the looper in the following steps:

- ① Draw the thread through the right side thread guide bar from back to front as shown (A).

NOTE:
If the thread is coming out from the thread guide notch, pass the thread through the thread guide hole again as shown (B).

- ① Thread guide bar

- ② Slip the thread into the thread guide plate on the machine as shown.

- ② Thread guide plate

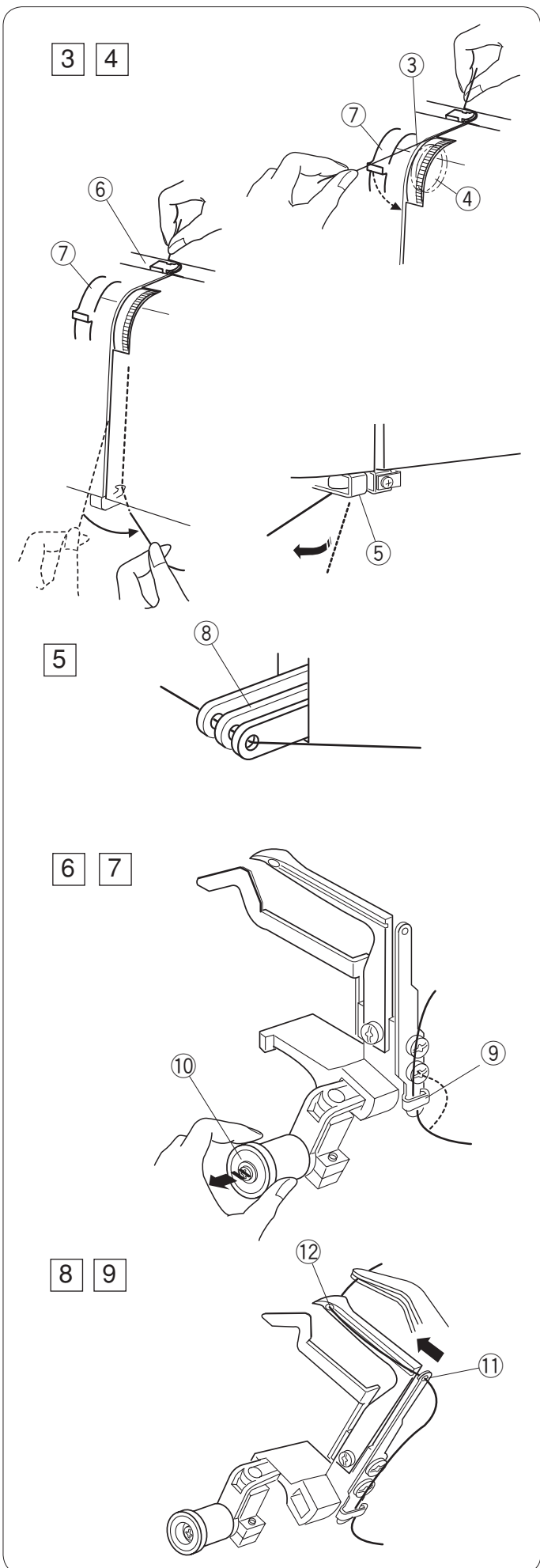

3 Hold the thread at both ends and tug gently to ensure the thread is correctly inserted between the tension disks. (If the presser foot lifter is raised, the thread easily inserts between the tension disks.)

- 3 Tension dial
- 4 Tension disks

4 Draw the thread down into the looper thread guide (A).

* Pull the thread to pass it through the looper thread guide (A) while holding the thread at the thread guide plate.

- 5 Looper thread guide (A)
- 6 Thread guide plate
- 7 Looper thread tension switching lever

5 Pass the thread through the eyes of the looper take-up levers.

- 8 Looper take-up lever

NOTE:

Be sure to raise the needles to the highest position so the eyes of the looper take-up levers will align.

6 Slip the thread behind the looper thread guide (B) from the right.

- 9 Looper thread guide (B)

7 Pull the looper release knob and the looper will slant to the right for easy access.

- 10 Looper release knob

8 Pass the thread through the eye of the looper thread guide (D) then through the eye of looper. Draw the thread end 4" (10 cm) to the back

- 11 Looper thread guide (D)
- 12 Eye of the looper

NOTE:

You may use a pair of tweezers.

9 Push the looper in the direction of the arrow, back to the original position.

STITCH TYPES

Triple Cover Stitch

The triple cover stitch is sewn with all three needles. This stitch forms three parallel rows of the straight stitch on the right side, ideal for hemming, attaching elastics, decorative stitches etc.

- ① Left needle
- ② Center needle
- ③ Right needle

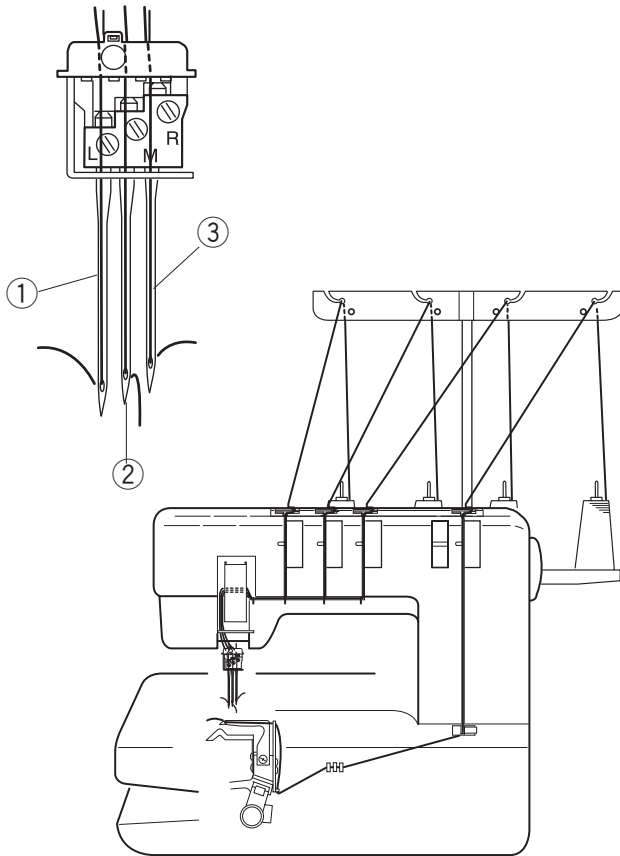

Type of Fabric		Needle Size	Type of Thread
Light to medium weight	Fine knits Fine Jersey	80/12 or 90/14	#60-90 Spun
Heavyweight	Jersey Fleece	90/14	#60 Spun

NOTE: The machine is installed with the #80/12 needles.

Balancing the thread tension

① Set the tension dials as follows:

- ① Left needle thread tension dial: 4
- ② Center needle thread tension dial: 4
- ③ Right needle thread tension dial: 4
- ④ Looper thread tension dial: 3

② Check the tension balance by test stitching on the same fabric and threads as actual garments. Fine-tune the tension as necessary.

Balanced tension:

The rows of stitches on the right side of the fabric are straight and even. The looper thread forms the dual rows of squares with diagonals.

- ① Wrong side of the fabric
- ② Looper thread
- ③ Left needle thread
- ④ Center needle thread
- ⑤ Right needle thread

(A) If the needle thread tension is too loose:

- The stitches on the right side are irregular and loose.
- There is a gap between head and tail of the looper thread crossing points.

Tighten the needle thread tension, and/or loosen the looper thread tension to correct it.

(B) If the needle thread tension is too tight:

- The fabric puckers.
- Loosen the needle thread tension, and/or tighten the looper thread tension to correct it.

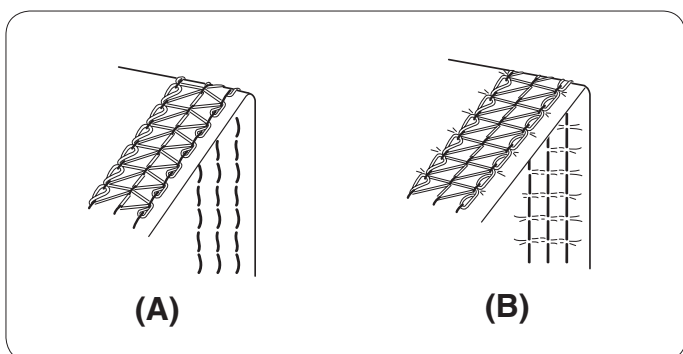
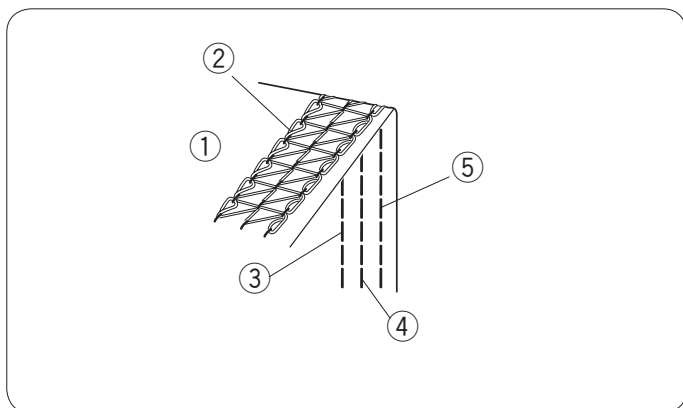
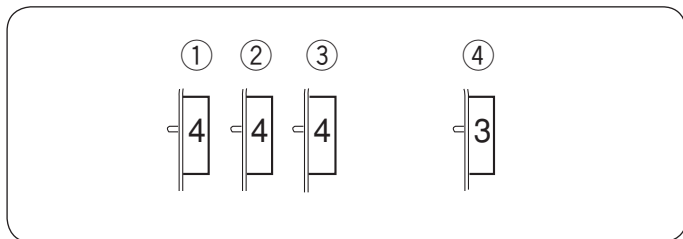

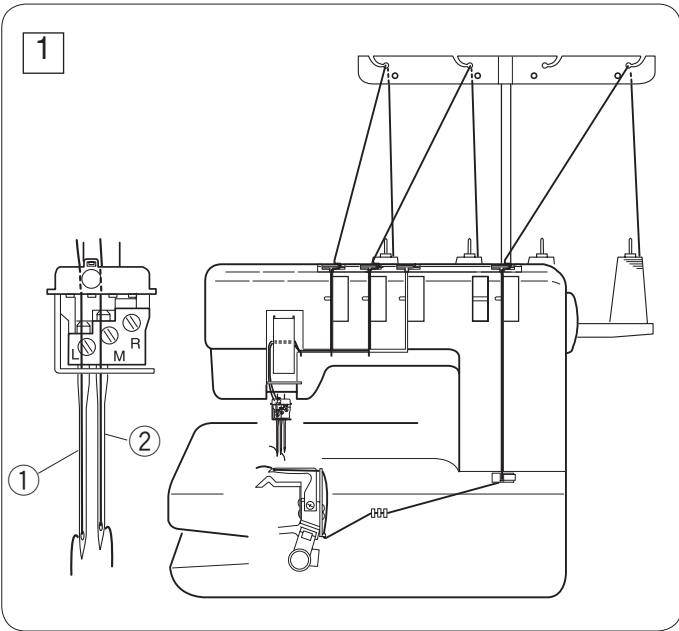

Cover Stitch

This stitch is sewn with two needles and forms two parallel rows of the straight stitch on the right side, widely used on cuffs and stretch welts of T-shirts etc.

There are three types of cover stitch:

- Narrow-left (3 mm wide)
- Narrow-right (3 mm wide)
- Wide (6 mm wide).

1 Narrow-left (3 mm wide)

Remove the right needle (see page 14). Thread the looper, left and center needles.

NOTE:

Tighten the needle clamp screw on the side that is not being used to prevent losing the screw.

- ① Left needle
- ② Center needle

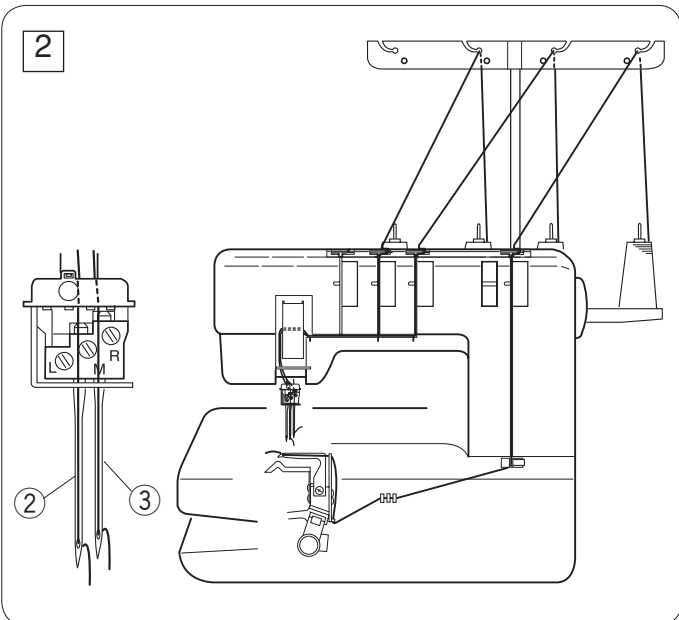

2 Narrow-right (3 mm wide)

Remove the left needle (see page 14). Thread the looper, right and center needles.

NOTE:

Tighten the needle clamp screw on the side that is not being used to prevent losing the screw.

- ② Center needle
- ③ Right needle

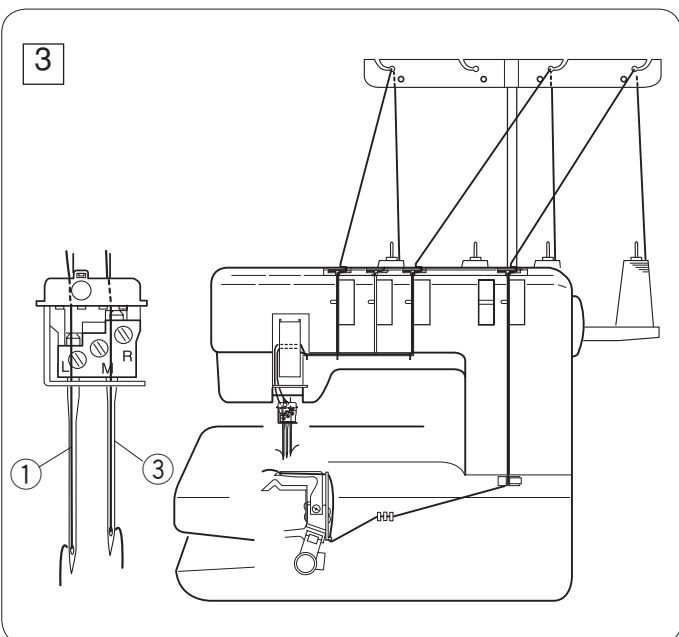

3 Wide (6 mm wide)

Remove the center needle (see page 14). Thread the looper, right and left needles.

NOTE:

Tighten the needle clamp screw on the side that is not being used to prevent losing the screw.

- ① Left needle
- ③ Right needle

Balancing the thread tension

① Set the tension dials as follows:

For narrow-left (3 mm wide):

① Left needle thread tension dial:	4
② Center needle thread tension dial:	4
③ Looper thread tension dial:	3

For narrow-right (3 mm wide):

① Center needle thread tension dial:	4
② Right needle thread tension dial:	4
③ Looper thread tension dial:	3

For Wide (6 mm wide):

① Left needle thread tension dial:	4
② Right needle thread tension dial:	4
③ Looper thread tension dial:	3

② Check the tension balance by test stitching on the same fabric and threads as actual garment. Fine-tune the tension as necessary.

Balanced tension:

The rows of stitches on the right side of the fabric are straight and even. The looper thread forms a row of squares with diagonals.

- ① Wrong side of the fabric
- ② Looper thread
- ③ Left needle thread
- ④ Right needle thread

(A) If the needle thread tension is too loose:

- The stitches on the right side are irregular and loose.
- There is a gap between head and tail of the looper thread crossing points.

Tighten the needle thread tension, and/or loosen the looper thread tension to correct it.

(B) If the needle thread tension is too tight:

- The fabric puckers.

Loosen the needle thread tension, and/or tighten the looper thread tension to correct it.

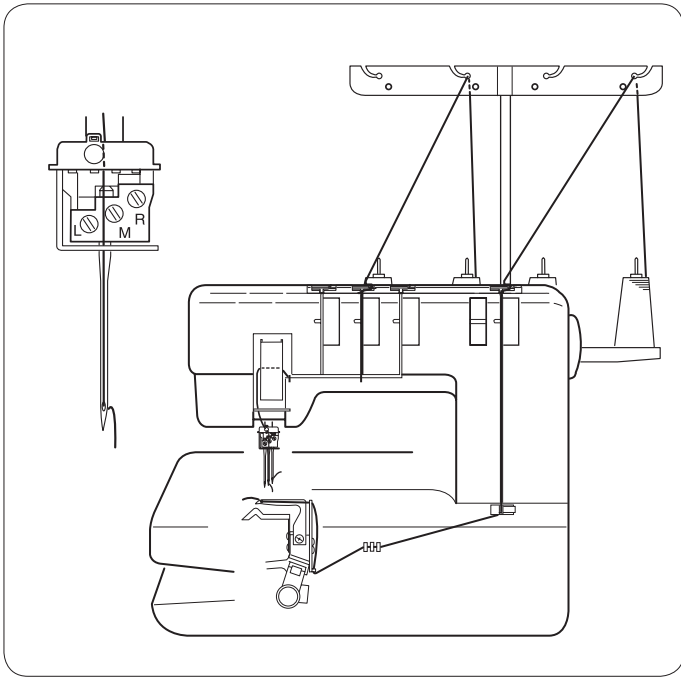

Chain Stitch

This stitch is sewn with a single needle and forms a chain of looper thread on the wrong side of the fabric.

This is a durable and flexible stitch used for seaming knit fabrics, attaching elastics, attaching bias tapes etc.

Thread one of the three needles and looper. Remove the needles not to be used (see page 14).

NOTE:

Tighten the needle clamp screws on the sides that are not being used to prevent losing the screws.

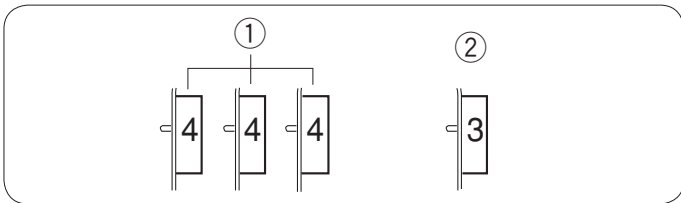

Balancing the thread tension

1 Set the tension dials as follows:

- ① Needle thread tension dial: 4
- ② Looper thread tension dial: 3

NOTE:

Adjust the tension dial for the needle being used.

2 Check the tension balance by test stitching on the same fabric and threads as actual garment. Fine-tune the tension as necessary.

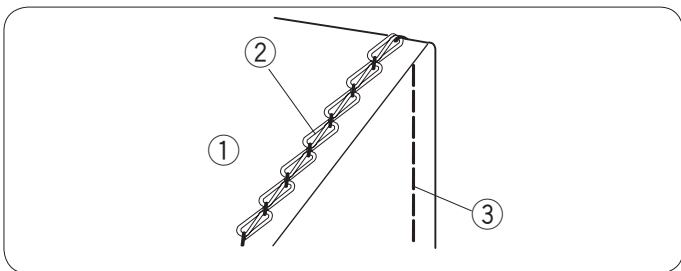

Balanced tension:

The straight stitch on the right side of the fabric is straight and even. The looper thread forms a chain.

- ① Wrong side of the fabric
- ② Looper thread
- ③ Needle thread

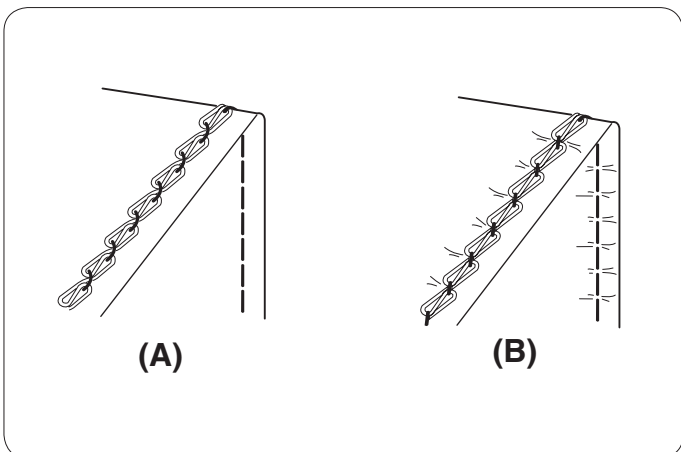

(A) If the needle thread tension is too loose:

- The stitch on the right side is irregular and loose.
- The needle thread forms loops on the wrong side of the fabric.

Tighten the needle thread tension, and/or loosen the looper thread tension to correct it.

(B) If the needle thread tension is too tight:

- The fabric puckers.

Loosen the needle thread tension, and/or tighten the looper thread tension to correct it.

Curling Problem

To avoid the curling problem of the fabric being sewn, switch the looper thread tension switching lever to "SOFT", and adjust the stitch length to "3.0" or higher.

If the skipped stitch occurs, adjust the stitch length to a higher length, or switch the thread tension switching lever to "TIGHT", and adjust the thread tension.

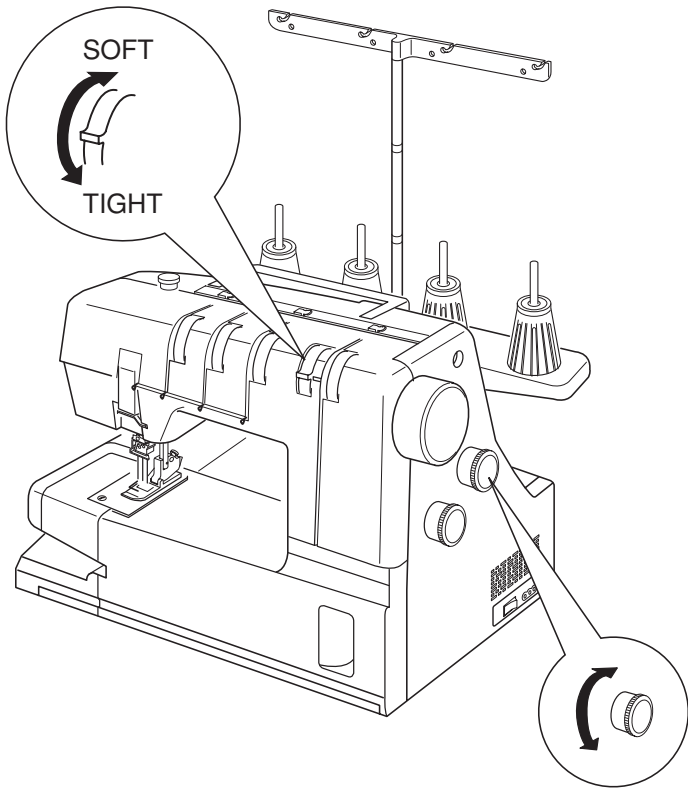

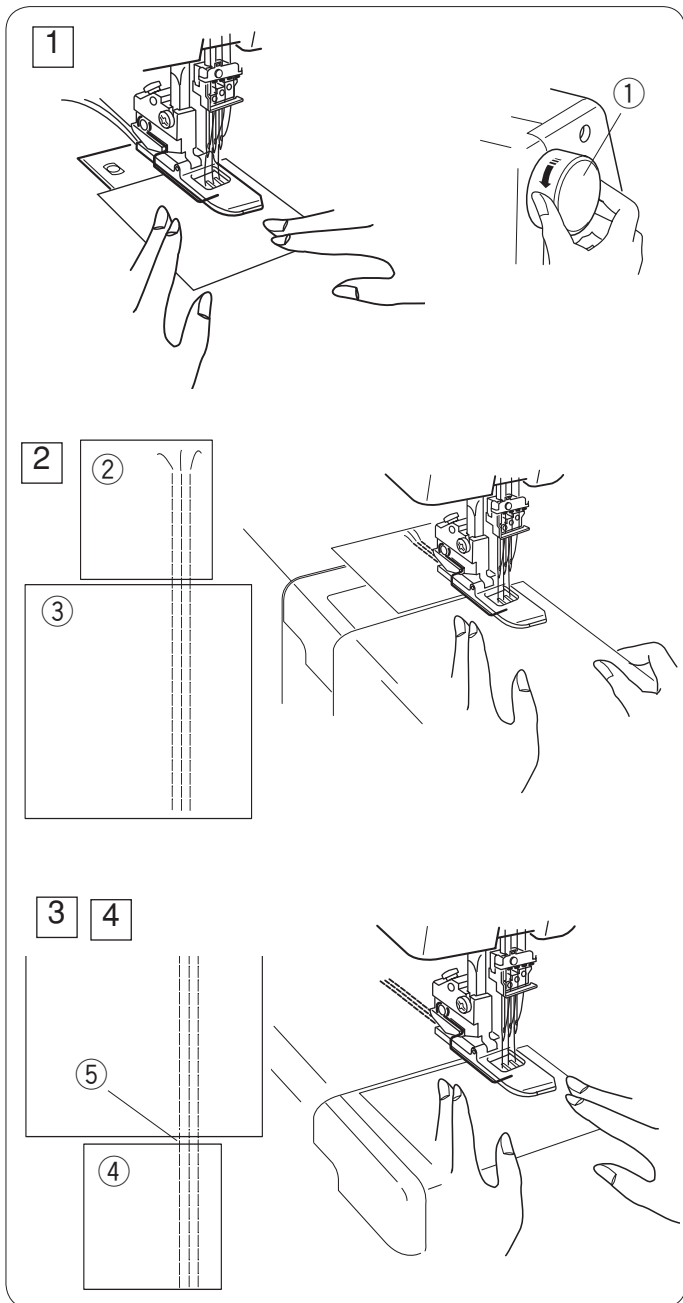

Finishing the Seam

To achieve the best results, use a piece of scrap fabric at the beginning and end of the seam.

Beginning of the seam

- 1 Raise the presser foot and insert a piece of scrap fabric under the foot. Lower the foot and turn the handwheel several times toward you. Depress the foot control to start sewing slowly.

① Handwheel

- 2 Stop sewing at the end of the scrap fabric. Insert the work fabric after the scrap as shown, then start sewing on the work fabric.

② Scrap fabric

③ Work fabric

End of the seam

- 3 Stop sewing at the end of the work fabric. Insert another piece of scrap fabric after the work fabric as shown, then sew through the scrap.

④ Another scrap fabric

- 4 Cut the connecting threads between the work fabric and scrap fabric.

⑤ Connecting threads

Knitting the threads

Draw the needle threads to the wrong side of the fabric by using a pair of tweezers and knot them together.

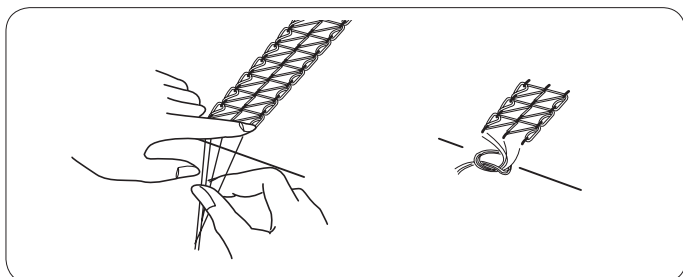

Removing the Fabric in the Middle of the Stitching

1 Raise the needles to their highest position by turning the handwheel toward you.

① Handwheel

2 Raise the presser foot with the presser foot lifter.

② Presser foot lifter

3 Pull the needle threads before the needle eyes. This prevents the threads from being caught when removing the fabric.

4 Pull the fabric to the rear.

5 Remove the fabric and cut the threads with the thread cutter.

③ Thread cutter

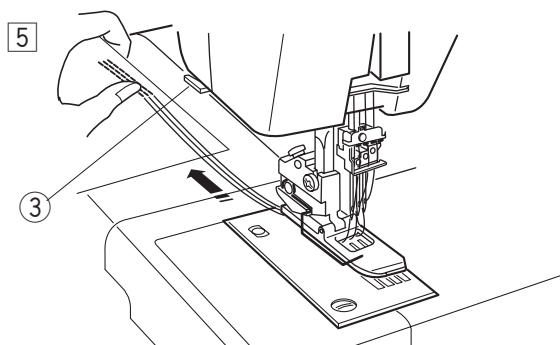
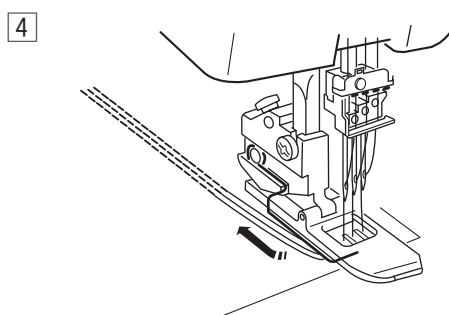
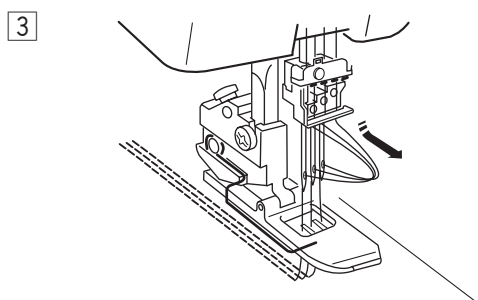
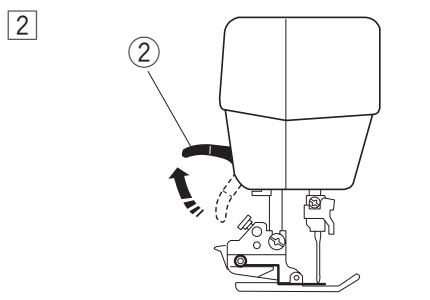
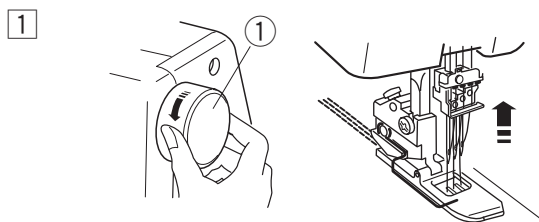

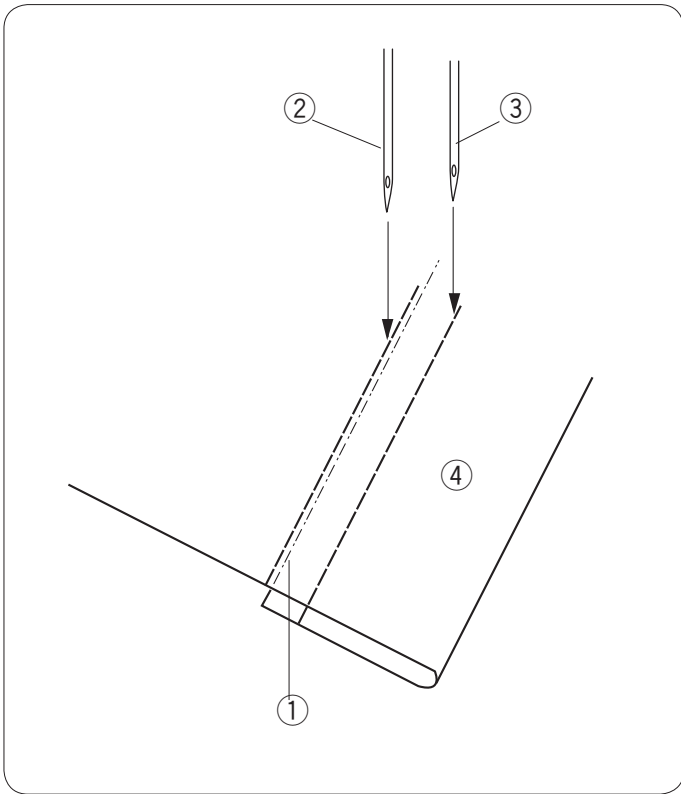

Hemming with the Cover Stitch

- 1 Fold up the edge of the fabric to the wrong side and press.
- 2 Draw a line with a tailor's chalk on the right side of the fabric to mark the fabric edge.
- 3 Place the fabric so the left needle drops just to the left side of the marked line. Lower the presser foot.
- 4 Sew carefully along the marked line.
- 5 After finishing sewing, raise the presser foot and remove the fabric to the rear.
- 6 Draw the needle threads to the wrong side of the fabric and knot them together.

- 1 Marked line
- 2 Left needle
- 3 Right needle
- 4 Right side of the fabric

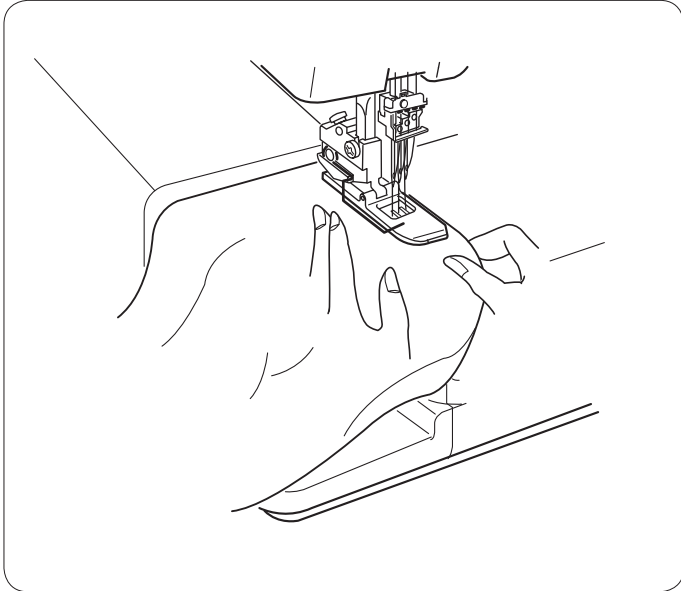

Free Arm Hemming

The extension table can be detached for free arm hemming on the tubular parts of the garments, such as sleeves, cuffs etc.

- 1 Detach the extension table (see page 8).
- 2 Stitch the hem in the same way as hemming with cover stitch.
- 3 Continue to sew over the stitches 2" (4 to 5 cm) beyond the beginning of the seam and stop the machine.
Cut the threads at the beginning and at the end.

Triple Cover Stitch Applications

Hemming on sleeves and waistlines

- ① Sleeve
- ② Waistline

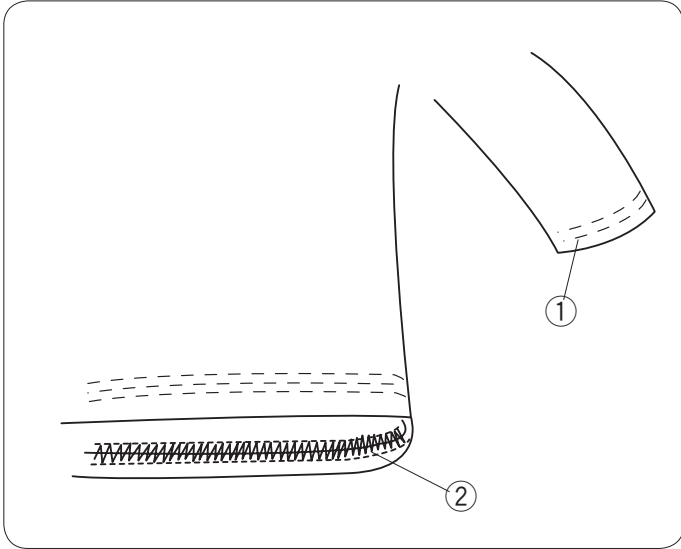

Attaching laces and tapes

- ① Tape or lace
- ② Right side of the fabric
- ③ Wrong side of the fabric

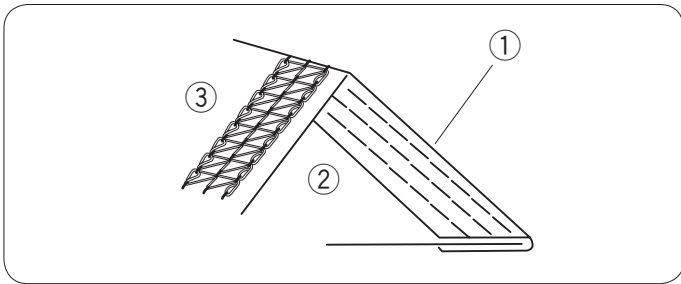

Attaching elastics

- ① Right side of the fabric
- ② Wrong side of the fabric
- ③ Elastic

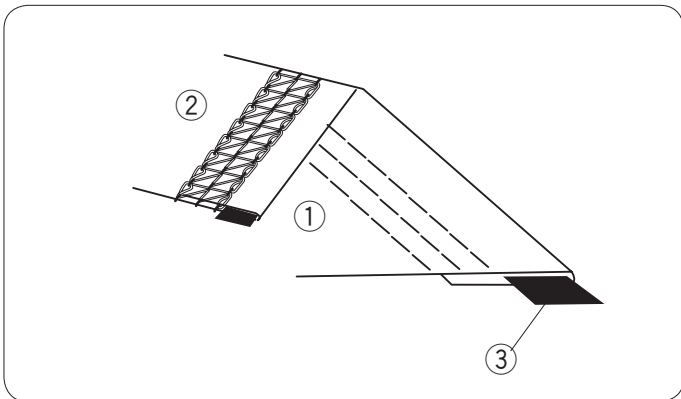

Decorative stitch

- ① Right side of the fabric
- ② Wrong side of the fabric

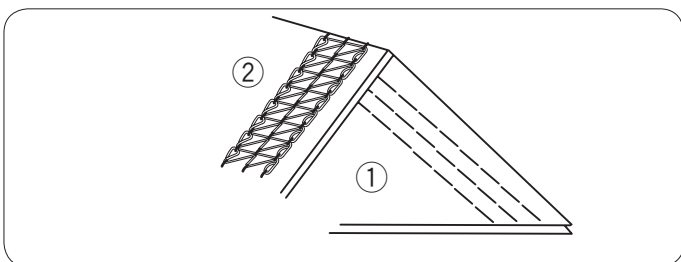

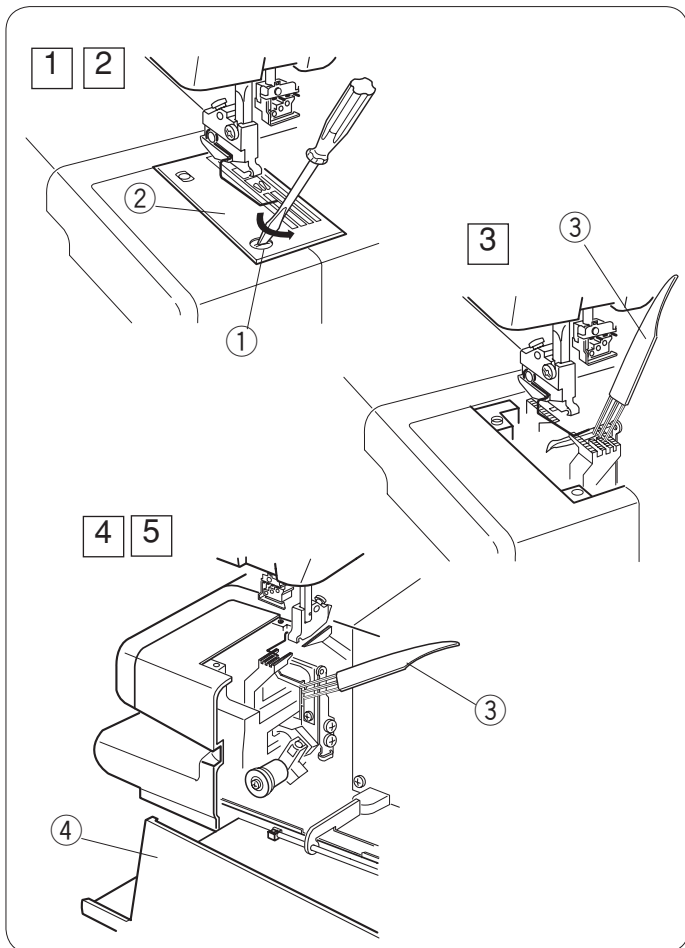

CARE OF YOUR MACHINE

Cleaning the Feed Dogs and Looper Area



WARNING:

Turn the power switch off and unplug the machine before cleaning.

NOTE:

Do not dismantle the machine in any way other than what is explained in this section.

- 1 Remove the presser foot and needles.
- 2 Remove the setscrew and needle plate.
- 3 Clean the feed dogs with a lint brush.
 - ① Setscrew
 - ② Needle plate
 - ③ Lint brush
- 4 Open the looper cover and clean the looper and surrounding area with the lint brush.
- 5 Replace the needle plate, needles and presser foot. Close the looper cover.
 - ④ Looper cover

Troubleshooting

Problem	Cause	Reference
Needle thread breaks.	<ol style="list-style-type: none"> 1. The machine is not threaded correctly. 2. The thread tension is too tight. 3. The needle is bent or blunt. 4. The needle is not set correctly. 5. A wrong needle is used. 	<p>See pages 16 - 26.</p> <p>See pages 28, 32, 34.</p> <p>See page 14.</p> <p>See page 14.</p> <p>See page 14.</p>
Needle bends or breaks.	<ol style="list-style-type: none"> 1. The needle is bent or blunt. 2. The needle is not set correctly. 3. The needle clamp screw is loose. 4. The fabric is forcedly pulled. 	<p>See page 14.</p> <p>See page 14.</p> <p>See page 14.</p> <p>Do not pull the fabric.</p>
Skipped stitches	<ol style="list-style-type: none"> 1. The needle is not set correctly. 2. The needle is bent or blunt. 3. The tension is out of balance. 4. The machine is not threaded correctly. 	<p>See page 14.</p> <p>See page 14.</p> <p>See pages 28, 32, 34.</p> <p>See pages 18 - 26.</p>
Seam puckering	<ol style="list-style-type: none"> 1. The tension is out of balance. 	<p>See pages 28, 32, 34.</p>
Machine does not operate.	<ol style="list-style-type: none"> 1. The machine is not connected to the power supply. 2. The foot control is not plugged in firmly. 	<p>See page 6.</p> <p>See page 6.</p>