

Instruction Book

Memory Craft 6700P

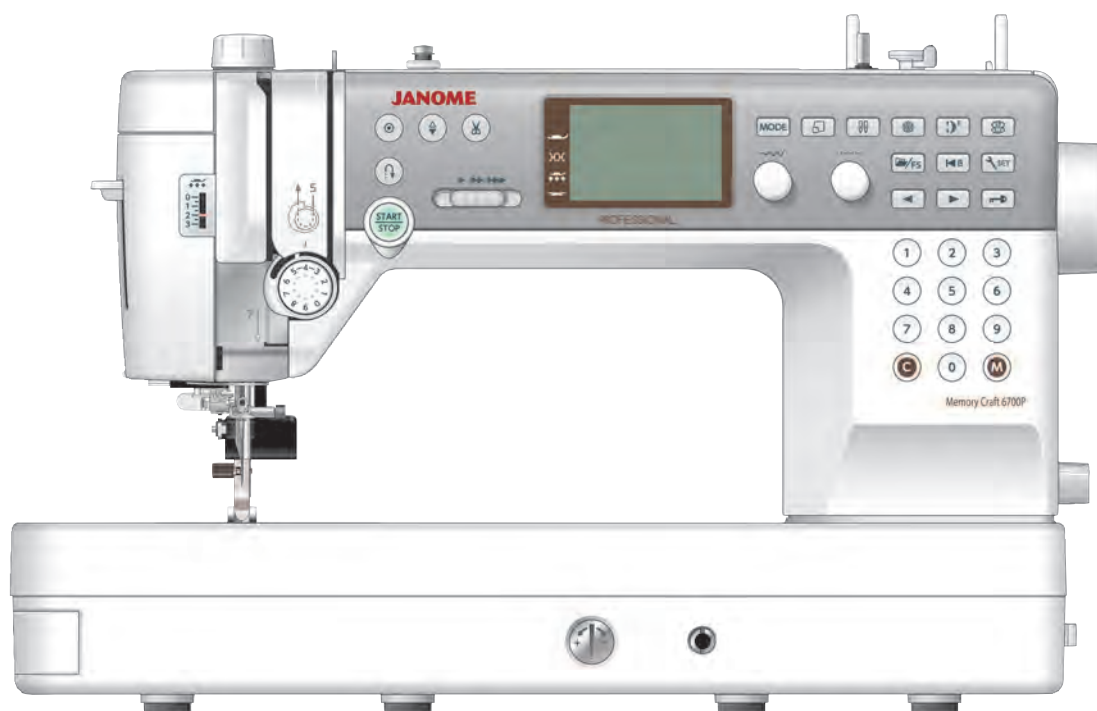

TABLE OF CONTENTS

ESSENTIAL PARTS	
Names of Parts.....	4
Standard Accessories.....	5
Extension Table.....	6
Stitch Reference Chart.....	7
GETTING READY TO SEW	
Connecting the Power Supply.....	8
Operating Instructions.....	8
Controlling Sewing Speed.....	9
Foot Control.....	9
Machine Operating Keys.....	10
Function Keys and Jog Dials.....	11-12
Raising and Lowering the Presser Foot.....	13
Knee Lifter.....	13
Replacing the Presser Foot.....	14
Adjusting the Foot Pressure.....	15
Removing and Attaching the Foot Holder.....	15
Attaching the Dual Feed Foot AD.....	16
Attaching the Professional Grade Foot HP.....	16
Attaching the Darning Foot PD-H.....	16
Replacing Needles.....	17
Winding the Bobbin.....	18-20
Inserting the Bobbin.....	21
Threading the Machine.....	22-23
Built-in Needle Threader.....	24
Drawing up the Bobbin Thread.....	25
Replacing the Needle Plate.....	26
Balancing Thread Tension.....	27
Dropping the Feed Dog.....	28
Selecting the Sewing Mode.....	29
Selecting the Pattern.....	30
Mode 1: Direct pattern selection mode.....	30
Customizing direct pattern selection.....	31
Pattern Selection in Mode 2 and Mode 3.....	32
• Using numeral keys.....	32
• Using jog dials.....	32
• Using arrow keys.....	33
Customizing Machine Settings.....	33
Screen brightness.....	34
Buzzer sound.....	34
Auto thread cutting.....	34
Needle stop position.....	34
Adjustable start-up speed (START/STOP key).....	34
Adjustable start-up speed (Foot control).....	35
Favorite stitch adjustment (FS).....	35
Resume setting.....	35
Bobbin winding speed.....	35
Language selection.....	35
Auto-off timer.....	36
Reset all to default.....	36
BASIC SEWING	
Straight Stitch.....	37-39
Sewing from the Edge of Thick Fabric.....	37
Changing Sewing Direction.....	37
Turning a Square Corner.....	37
Securing Seams.....	38
Cutting Threads.....	38
Needle Plate Guides.....	38
Adjusting the Needle Drop Position.....	39
Adjusting the Stitch Length.....	39
Favorite Stitch Adjustment.....	40
Sewing with the Dual Feed Device.....	41
Sewing with the Professional grade foot HP.....	42
Variety of Straight Stitches.....	43-44
Straight Stitch in Center Needle Position.....	43
Lock-a-matic Stitch.....	43
Locking Stitch.....	43
Straight Stitch in Left Needle Position.....	44
Triple Stretch Stitch.....	44
Stretch Stitches.....	44
Zipper Sewing.....	45-47
Rolled Hem.....	48
Gathering.....	49
Pintucking.....	49
Basting.....	50
Zigzag Stitches.....	51
Adjusting the stitch length.....	51
Adjusting the stitch width.....	51
Variety of Overcasting Stitches.....	52-53
Multiple Zigzag Stitch.....	52
Overcasting Stitch.....	52
Knit Stitch.....	52
Double Overcasting Stitch.....	53
Overlocking Stitch.....	53
Blind Hemming.....	54
Shell Tuck.....	56
Variety of Buttonholes.....	57
Sensor (Square) Buttonhole.....	58-61
Adjusting the buttonhole width.....	61
Adjusting the buttonhole stitch density.....	61
Using the Stabilizer Plate.....	62
Automatic (square) Buttonhole.....	63-64
Round End and Fine Fabric Buttonholes.....	65
Keyhole Buttonholes.....	65
Stretch Buttonhole.....	65
Knit Buttonhole.....	65
Corded Buttonhole.....	66
Button Sewing.....	67
Darning.....	68
Tacking.....	69
Eyelet.....	70
DECORATIVE STITCHES	
Applique.....	71
Fringing.....	72
Drawn Work.....	72-73
Smocking.....	73
Fagoting.....	74
Scallop.....	74
Patchwork Piecing.....	75
Angle Scales on the Needle Plate.....	75
Patchwork.....	75
Quilting.....	76
Stippling.....	76
Clasp Stitch.....	77
Free Motion Quilting (1).....	77-78
Free Motion Quilting (2).....	78
Satin Stitches.....	79
Elongation ratio.....	79
Twin Needle Sewing.....	80-81
PROGRAMMING A PATTERN COMBINATION	
Pattern Combination.....	82
Editing a Pattern Combination.....	83

TABLE OF CONTENTS

Deleting a Pattern.....	83
Inserting a Pattern.....	84
Duplicating a Pattern.....	84
Programming Auto-lock Stitch.....	85
Automatic Thread Cutting.....	85
Mirror Image.....	86
Pattern Combination with a Mirror Image.....	87
Sewing the Pattern from the Beginning.....	88
Sewing the Pattern Combination from the Beginning ..	88
Bridge Stitches.....	89-90
Uniform Stitch Adjustment.....	90
Individual Stitch Adjustment.....	91

MONOGRAMMING

Entering Monogram Letters with Jog Dials.....	92
• Selecting a character style.....	92
• Selecting a font style.....	93
• Selecting a letter (character).....	93
Programming a Monogram.....	94
Spacing.....	95
Monogram size.....	95
Reducing the size of letters.....	95

STORING AND RECALLING A PATTERN COMBINATION

Storing a Pattern Combination.....	96
Recalling a Stored Combination.....	97
Deleting a Stored Combination.....	97

Correcting Distorted Stitch Patterns.....	98
---	----

CARE AND MAINTENANCE

Cleaning the Hook Area.....	99
Problems and Warning Signals.....	100-101
Troubleshooting.....	102

Stitch Chart.....	103
Stitch Chart (Monogram).....	104

ESSENTIAL PARTS

Names of Parts

- ① Foot pressure dial
- ② Thread take-up lever
- ③ Left thread guide
- ④ Upper thread guide
- ⑤ Stitch reference chart
- ⑥ LCD screen
- ⑦ Retractable thread guide
- ⑧ Bobbin winder spindle
- ⑨ Bobbin winder stopper
- ⑩ Bobbin thread cutter (upper)
- ⑪ Function keys
- ⑫ Stitch length adjusting dial (Jog dial)
- ⑬ Stitch width adjusting dial (Jog dial)
- ⑭ Knee lifter socket
- ⑮ Feed balancing dial
- ⑯ Thread tension dial
- ⑰ Needle plate release lever
- ⑱ Thread cutter (on face plate)
- ⑲ Needle threader lever
- ⑳ Lower thread guide
- ㉑ Needle clamp screw
- ㉒ Needle bar thread guide
- ㉓ Needle
- ㉔ Zigzag foot A
- ㉕ Hook cover release button
- ㉖ Hook cover plate
- ㉗ Bobbin thread cutter
- ㉘ Needle plate
- ㉙ Feed dog
- ㉚ Foot holder
- ㉛ Setscrew
- ㉜ Lever
- ㉝ Needle threader
- ㉞ Buttonhole lever
- ㉟ Start/stop key
- ㊱ Reverse key
- ㊲ Auto-lock key
- ㊳ Needle up/down key
- ㊴ Thread cutter key
- ㊵ Speed control slider
- ㊶ Presser foot lifter
- ㊷ Dual feed mechanism
- ㊸ Spool pins
- ㊹ Power switch
- ㊺ Foot control jack
- ㊻ Machine socket
- ㊼ Drop feed lever
- ㊽ Dual feed adjusting dial
- ㊾ Thread cutter jack *
- ㊿ Handwheel
- 1 Right thread guide
- 2 Carrying handle
- 3 Bobbin winding tension disk
- 4 Stitch chart bracket

* Thread cutter switch is the optional item.

NOTE:

To carry the sewing machine, hold the carrying handle with your hand, and support the sewing machine with the other hand.

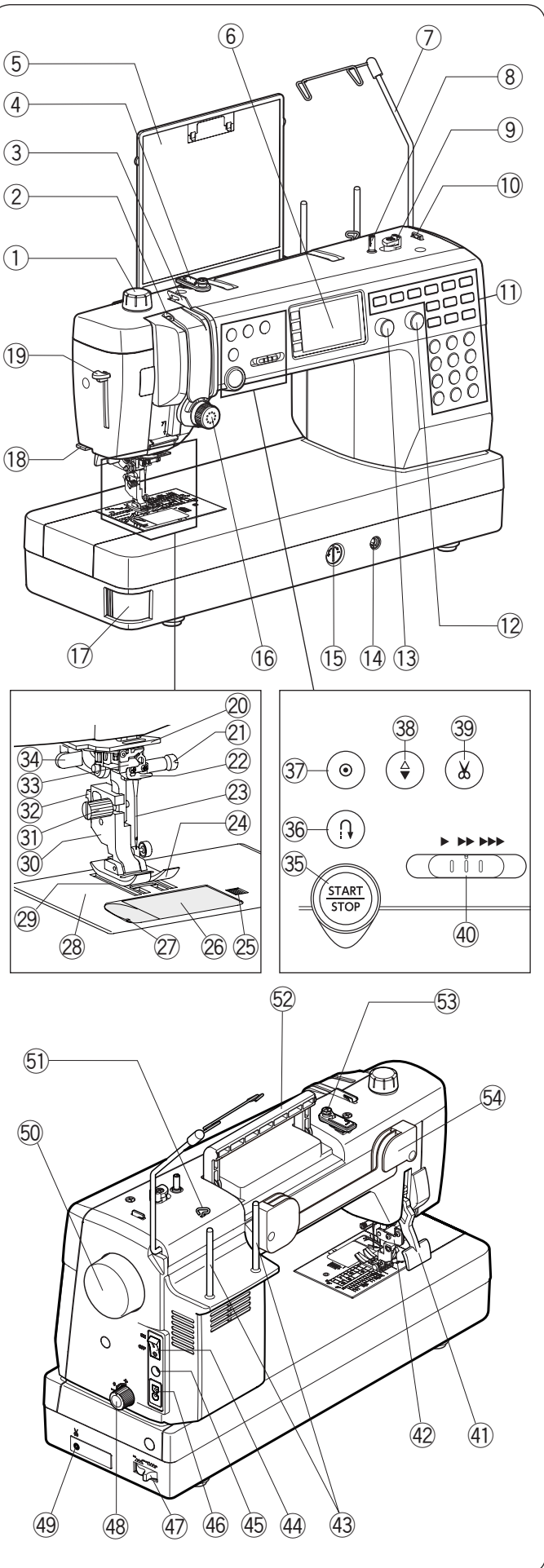

NOTE:

Sewing machine design and specifications are subject to change without prior notice.

Standard Accessories

No.	Part Name	Part No.
1	Zigzag foot A (Set on the machine)	859802006
2	Overedge foot M	859810007
3	Satin stitch foot F	859806011
4	Blind hemming foot G	859807001
5	Zipper foot E	859805009
6	Automatic buttonhole foot R	862822013
7	Stabilizer plate	859832016
8	Rolled hem foot D	859804008
9	Open toe satin stitch foot F2	859813000
10	Button sewing foot T	859811008
11	1/4" seam foot O	859814001
12	Professional grade foot HP	865803006
13	Darning foot PD-H	859839002
14	Convertible free motion quilting foot QB-S	858820018
15	Close-toe foot	858820111
16	Open-toe foot	858821019
17	Clear view foot	202002521
18	Dual feed foot holder	859817015
19	Dual feed foot AD (twin)	859819109
20	Button shank plate	832820007
21	Bobbin X 5 (1 set on the machine)	102261103
22	Needle set	859856005
23	Lint brush	802424004
24	Seam ripper (Buttonhole opener)	647808009
25	Quilting guide bar	755802001
26	Screwdriver	820832005
27	Net X 2	624806006
28	Spool holder (large) X 2	822020503
29	Spool holder (small) X 2	822019509
30	Spool holder (special) X 2	862408008
31	Spool rest	770850001
32	Knee lifter	846417011
33	Needle plate (set on the machine)	861606016
34	Straight stitch needle plate	862817107
35	Professional grade needle plate	865805008

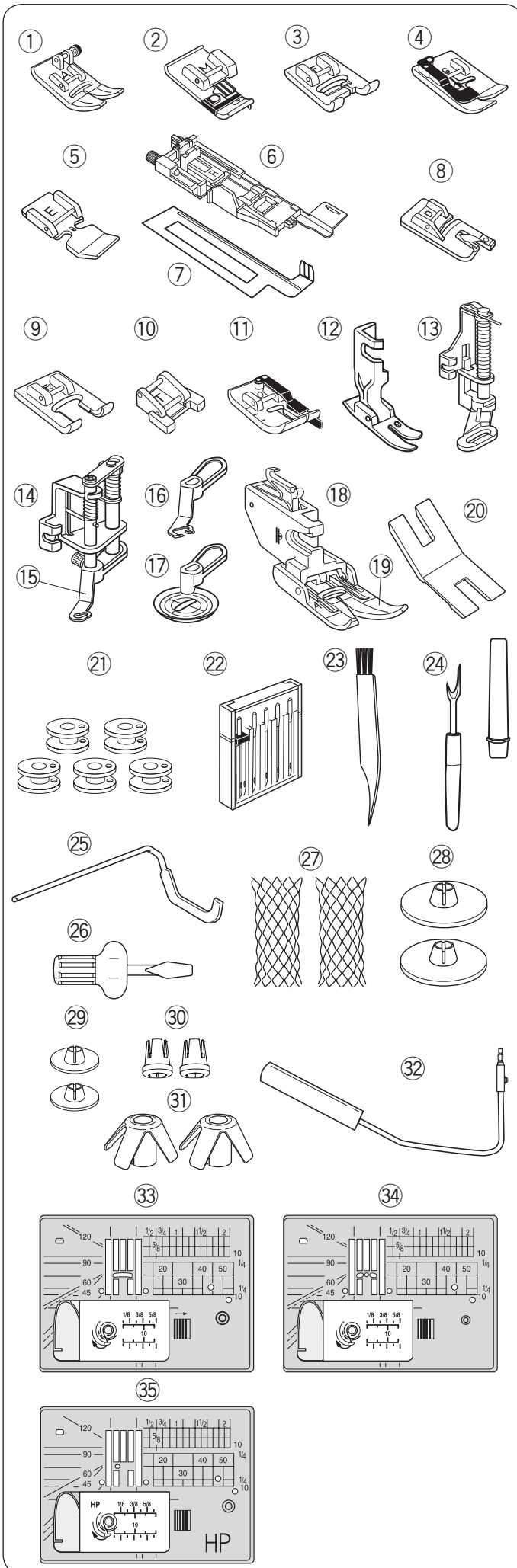

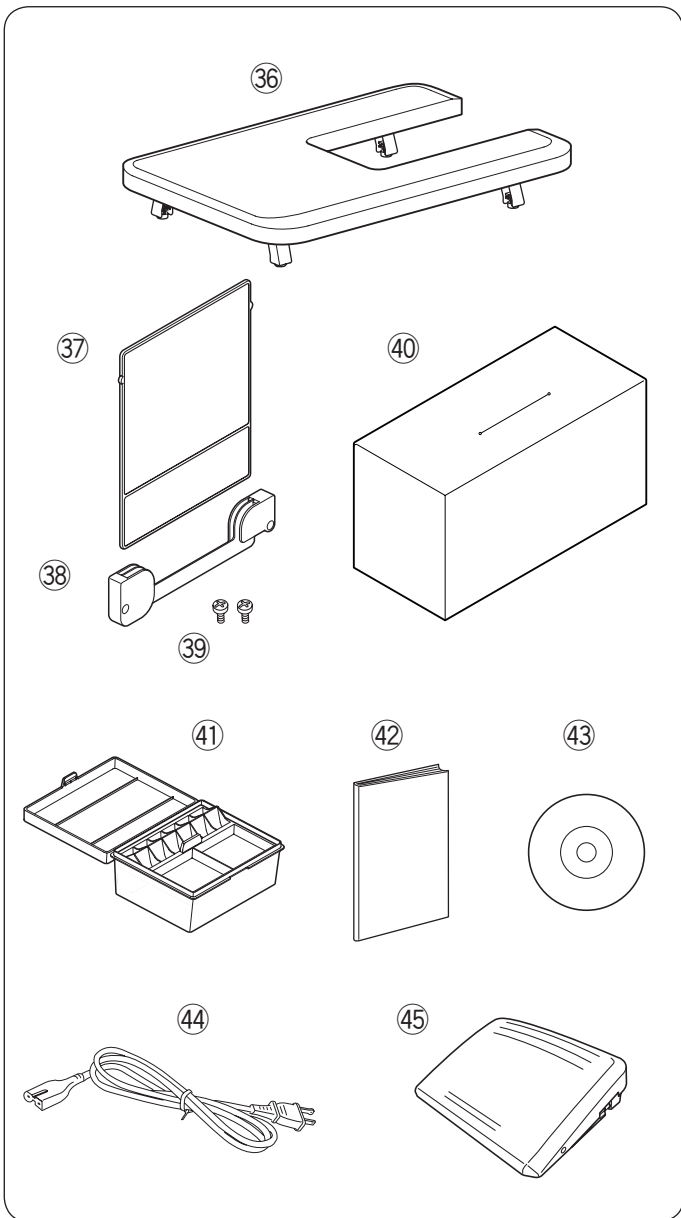

No.	Part Name	Part No.	
36	Extension table	846401001	
37	Stitch reference chart	866629009	
38	Stitch chart bracket	846285007	
39	Setscrew X 2	000163600	
40	Dust cover	767805001	
41	Accessory box	866801007	
42	Instruction book	866800006	
43	Instructional DVD	866804000	
44	Power cable*	U.S.A. and Canada	856519004
		U.K.	830377008
		Australia	830314018
45	Foot control	043170108	

*The power supply cable included may differ from the illustration.

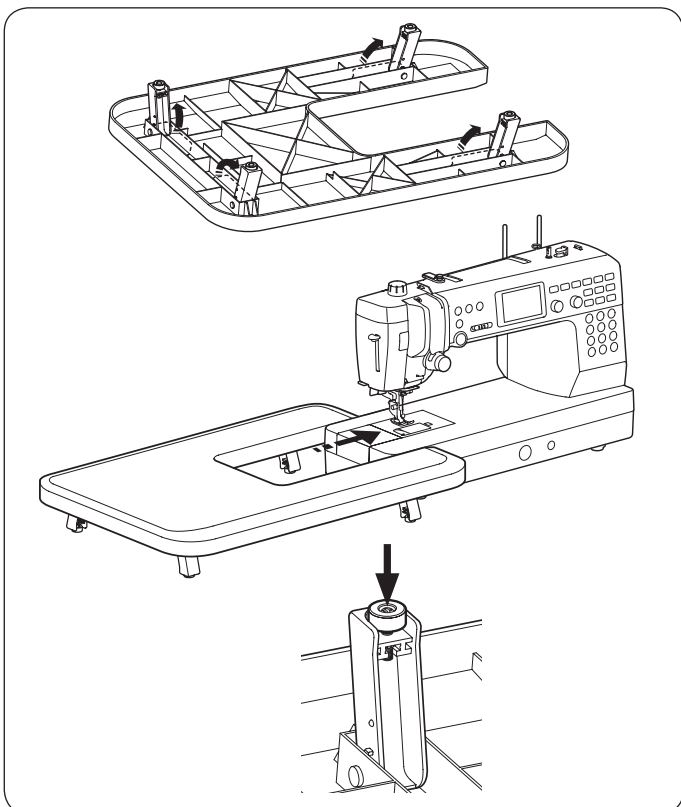

Extension Table Attaching the table

Spread the legs of extension table.

Holding the table with both hands and slide it gently to the right.

Adjusting the table height

Turn setscrews of the table legs with a screwdriver.

NOTE:

A Phillips screwdriver is required for adjusting the extension table height.

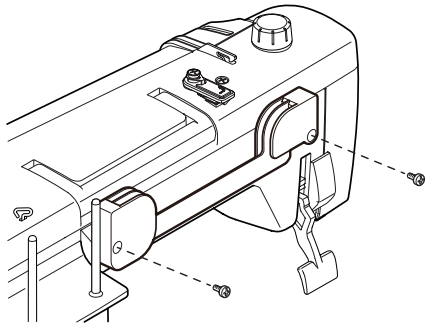

Stitch Reference Chart

Attaching the stitch chart bracket

Align the screws with the holes on the backside of the machine. Firmly tighten screws with screwdriver.

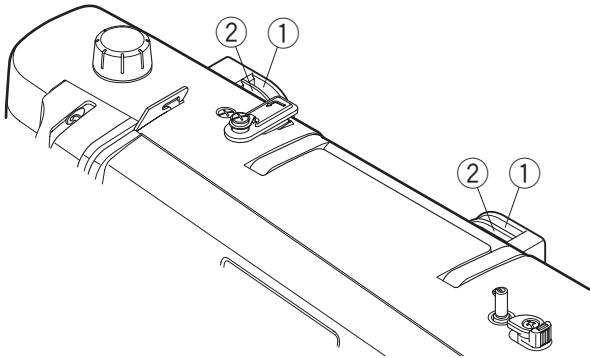

Stitch chart position

The stitch chart can be placed in two positions on the chart bracket, store or view.

- ① Back slots
- ② Front slots

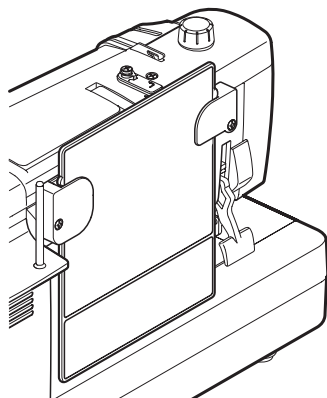

The back slots ① on the bracket are for store position. Slide stitch chart down between the back slots until the stitch chart stops.

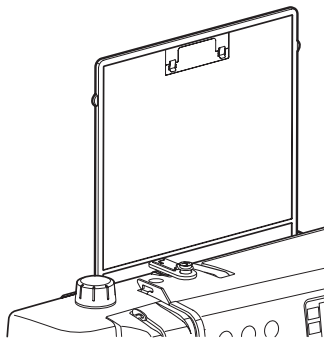

The front slots ② on the brackets are for view position. Pull up and out the stitch chart from back slots. Slide stitch chart down between the front slots.

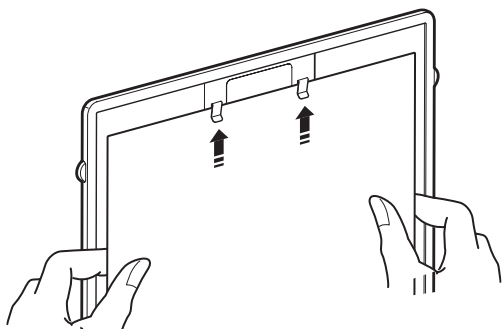

Clip board

Flip over the stitch chart (Mode 3 side) and then clip or sewing instructions, notes, etc., to board.

NOTE:

Do not clip multiple layers of paper or cardboard. Slide paper under clips; do not raise clips.

GETTING READY TO SEW

Connecting the Power Supply

- 1 First make sure the power switch ① is off.
- 2 Insert the machine plug ② of the power supply cable into the machine socket ③.
- 3 Insert the power supply plug ④ into the wall outlet ⑤, and turn the power switch ① on.

- ① Power switch
- ② Machine plug
- ③ Machine socket
- ④ Power supply plug
- ⑤ Wall outlet

NOTE:

Make sure to use the power supply cable that came with the machine.

If you turn off the power switch, wait for 5 seconds before turning it on again.



WARNING:

While in operation, always keep your eyes on the sewing area, and do not touch any moving parts such as the thread take-up lever, handwheel or needle.

Always turn off the power switch and unplug the machine from the power supply:

- when leaving the machine unattended.
- when cleaning the machine.

Do not place any objects on the foot control.

If you want to use the foot control, pull out the cord from the foot control and insert the pin connector into the jack on the machine.

- 1 First make sure the power switch ① is off.
- 2 Insert the machine plug ② of the power supply cable into the machine socket ③.
- 3 Draw out the cord from the foot control and insert the pin connector ④ into the jack ⑤ on the machine.
- 4 Insert the power supply plug ⑥ into the wall outlet ⑦, and turn the power switch ① on.

- ① Power switch
- ② Machine plug
- ③ Machine socket
- ④ Pin connector
- ⑤ Foot control jack
- ⑥ Power supply plug
- ⑦ Wall outlet

NOTE:

The start/stop key does not work when the foot control is connected.

Operating Instructions:

The symbol "O" on a switch indicates the "off" position of the switch.

For the U.S.A. and Canada only

Polarized plug (one blade wider than the other):

To reduce the risk of electric shock, this plug is intended to fit in a polarized outlet only one way. If it does not fit fully in the outlet, reverse the plug. If it still does not fit, contact a qualified electrician to install the proper outlet. Do not modify the plug in any way.

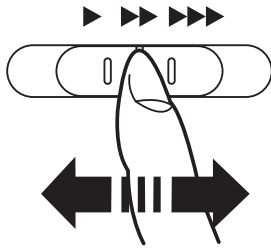

Controlling Sewing Speed

Speed control slider

You can limit the maximum sewing speed with the speed control slider according to your sewing needs. To increase the sewing speed, move the slider to the right. To decrease the sewing speed, move the slider to the left.

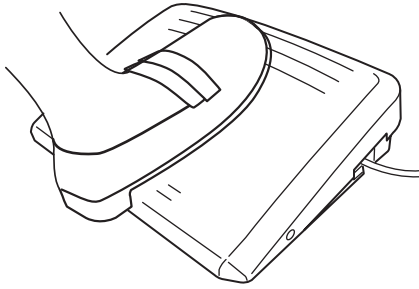

Foot Control

Pressing on the foot control can vary sewing speed. The harder you press the foot control, the faster the machine runs.

NOTE:

- The machine runs at the maximum speed set by the speed control slider when the foot control is fully depressed.
- You can select the desired start-up speed from slow, medium or high (refer to page 35).

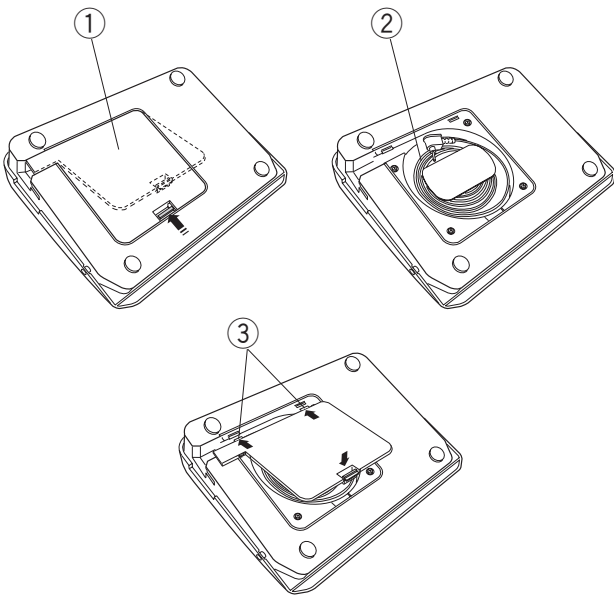

Cord storage

The cord of the foot control can be conveniently stored in the cord storage under the base cover of the foot control.

- ① Base cover
- ② Cord
- ③ Hooks

Operating Instructions:

Foot control model 21380 is for use with this sewing machine.

NOTE:

If you start the machine with the presser foot up, the LCD screen will advise you to lower the presser foot. Lower the presser foot and start sewing.

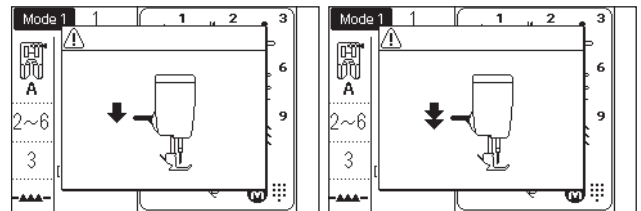

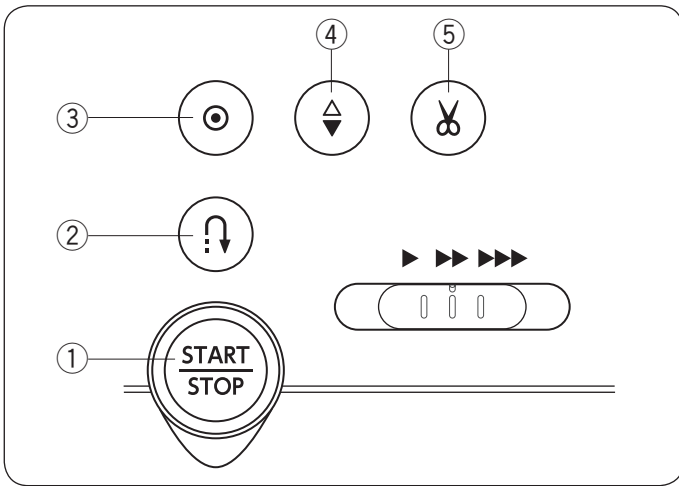

Machine Operating Keys

① Start/stop key

Press this key to start or stop the machine.

The machine starts running slowly for the first few stitches, it then runs at the speed set by the speed control slider. The machine runs slowly as long as this key is pressed.

The key will turn red when the machine is running, and green when it has been stopped.

Pressing and holding this key while sewing will slow down the sewing speed and the machine will stop when the key is released.

NOTE:

- The start/stop key cannot be used when the foot control is connected to the machine.
- You can select the desired start-up speed from slow, medium or high (refer to page 34).
- If you start the machine with the presser foot up, the LCD screen will advise you to lower the presser foot. Lower the presser foot and start sewing.

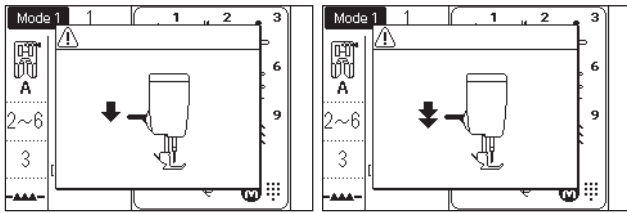

② Reverse key

• When following stitch patterns are selected;

Mode 1	Mode 2
① ④ ⑤ ⑥	001 004 006 007 008 011 082 083 084 135 136 137 138

The machine will sew in reverse as long as the reverse key is pressed. Release the key to sew forward.

When the machine is stopped and foot control is disconnected, the machine will sew in reverse slowly as long as the reverse key is pressed.

Release the key to stop the machine.

• When following stitch patterns are selected;

Mode 1	Mode 2
② ③	002 003 024 033 034

There will be particular functions of the reverse key when the patterns shown above are selected. Refer to pages 43, 63-64, 68 and 69 for instructions.

• When any other stitches are selected;

If you press the reverse key when sewing any other patterns, the machine will immediately sew locking stitches and automatically stop.

③ Auto-lock key

• When following stitch patterns are selected;

Mode 1	Mode 2
① ④ ⑤ ⑥	001 004 006 007 008 011 082 083 084 135 136 137 138

Press the auto-lock key to sew a locking stitch immediately. The machine will automatically stop.

When the machine is stopped, and press the auto-lock key to turn on the auto-lock function. The machine will immediately sew locking stitches and automatically stop when the machine is started.

• When any other stitches are selected;

Press the auto-lock key to sew a locking stitch at the end of current pattern. The machine will automatically stop.

When the machine is stopped, and press the auto-lock key to turn on the auto-lock function. The machine will sew a locking stitch at the end of the current pattern and automatically stop when the machine is started.

The machine will trim the threads automatically after locking the stitch when the auto thread cutting is turned on (refer to page 34).

④ Needle up/down key

Press this key to bring the needle bar up or down.

The machine will stop with the needle in down position. However, you can change the needle stop position in the machine setting mode (refer to page 34).

⑤ Thread cutter key

After finish sewing, press this key to trim the threads. The needle bar automatically rises after trimming the threads (refer to page 38).

After using auto thread cutting or threading the bobbin holder, you can start sewing without drawing up the bobbin thread.

NOTE:

The thread cutter key does not function:

- directly after turning on the power.
- when the presser foot is raised with the foot lifter.
- after being pressed 3 times in a row.

Use the thread cutter on the face plate if the thread is #30 or thicker (refer to page 38).

Function Keys and Jog Dials

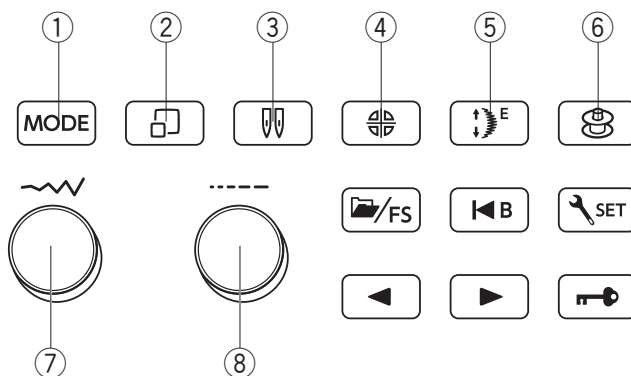
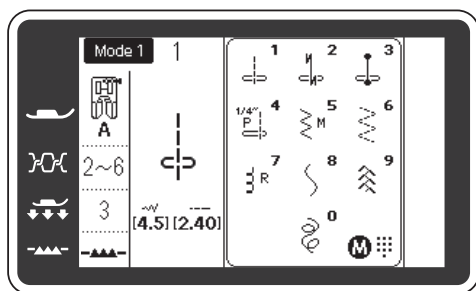

① **Mode key** (refer to page 29)

When the power is turned on, the pattern selection mode 1 is set automatically.

Each time you press the mode key, the mode will change from 1 to 3. The selected mode is indicated on the upper left corner of the LCD screen.

② **Stitch display key** (refer to pages 30, 32, 92)

In mode 1, press the stitch display key to open or close the direct pattern reference window.

In mode 2 or 3, press the stitch display key to open or close the pattern selection window.

③ **Twin needle key** (refer to page 81)

Press this key when sewing with a twin needle.

④ **Mirror image key** (refer to pages 86-87)

Press this key to sew a mirror image of the selected pattern.

⑤ **Elongation key** (refer to page 79)

Press this key to elongate satin stitch patterns.

⑥ **Bobbin winding key**

Press this key to wind the bobbin (refer to page 20).

⑦ **Stitch width adjusting dial** (refer to pages 32, 33, 39, 51, 90-93, 96-97, etc)

Turn this jog dial to alter the stitch width or needle drop position of the selected stitch pattern.

You can also alter the page number or move the cursor with this dial .

⑧ **Stitch length adjusting dial** (refer to pages 32, 33, 39, 51, 90-93, 96-97, etc)

Turn this jog dial to alter the stitch length of the selected pattern.

You can also move the cursor with this dial.

Function Keys and Jog Dials (Continued)

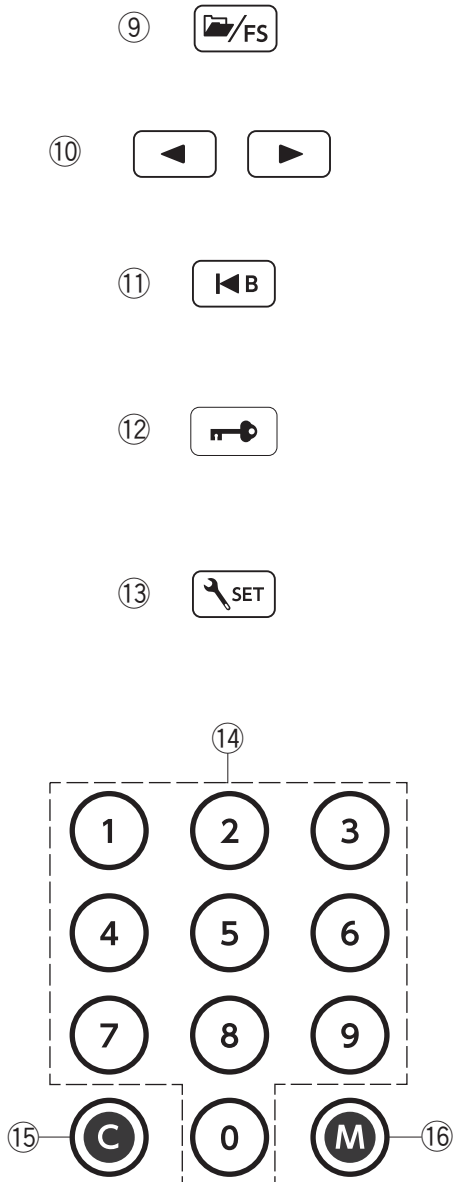
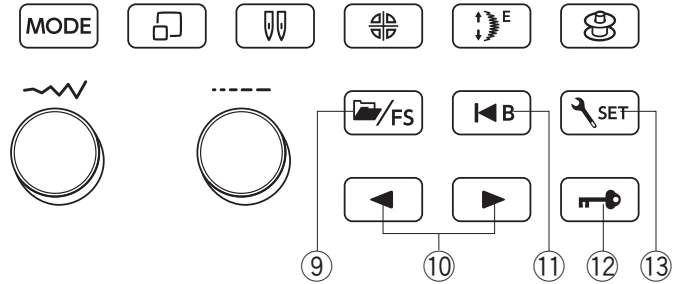
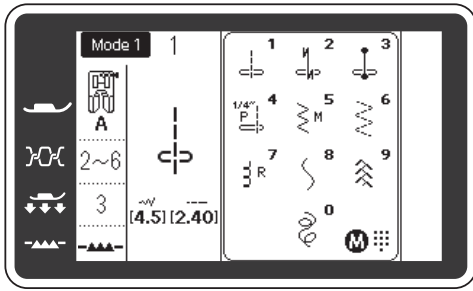

⑨ Folder/FS key

This key has two functions.

- 1: To stock or to recall the programmed pattern combinations (refer to page 96-97).
- 2: To register or to delete the favorite stitch settings (refer to page 40).

⑩ Arrow keys (refer to pages 33, 83, 87)

Press “◀” or “▶” to select the stitch pattern, edit the pattern combination, move the cursor or tun the page, etc.

⑪ Startover key (refer to page 88)

Press this key to sew a pattern combination from the beginning.

⑫ Lockout key

Press this key to lockout the machine when threading the machine, replacing the accessories etc.

To reduce the risk of injury, all keys except the lockout key are deactivated.

To unlock the machine, press this key again.

⑬ Set key (refer to page 33)

Press this key to enter the machine setting mode for customizing the machine settings.

⑭ Numeral keys (refer to page 30-32)

• Mode 1:

You can select direct stitch patterns by pressing corresponding keys.

• Mode 2, 3:

Enter a 3-digit pattern number to select the desired stitch pattern.

⑮ Clear key (refer to page 83)

Press this key to delete the memorized pattern or cancel the settings.

⑯ Memory key (refer to page 31, 32, 82)

Press this key to select the desired pattern, register programmed pattern combinations, or confirm settings.

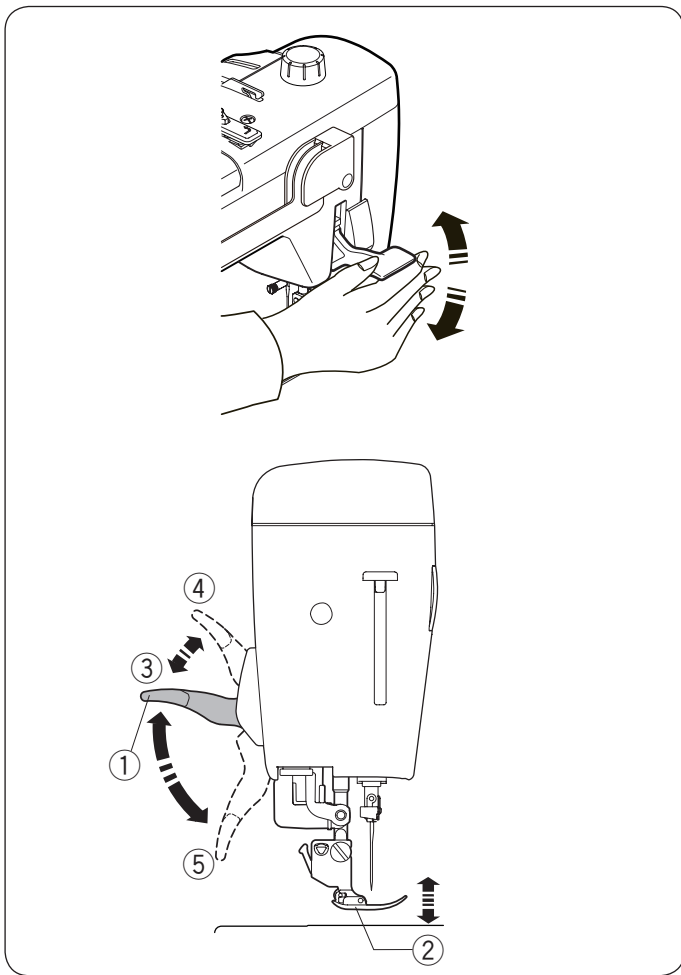

Raising and Lowering the Presser Foot

! CAUTION:

Do not turn the handwheel or press the up/down needle key when the presser foot is in extra lifted position. It may cause damage to the presser foot.

NOTE:

If you start the machine with the presser foot up, the LCD screen will advise you to lower the presser foot. Lower the presser foot and start sewing.

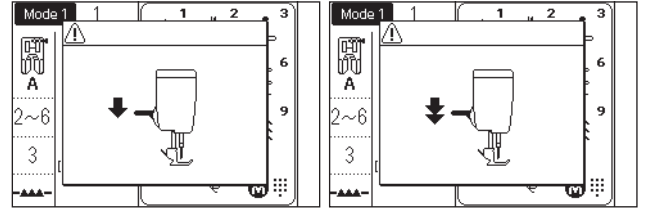

The presser foot lifter or the knee lifter raises and lowers the presser foot.

You can raise the presser foot about 7 mm (1/4") higher than the normal up position by exerting more pressure when lifting the presser foot. This allows for changing the needle plate and helps you to place layers of thick fabric.

- ① Presser foot lifter
- ② Presser foot
- ③ Up position
- ④ Extra lifted position
- ⑤ Down position

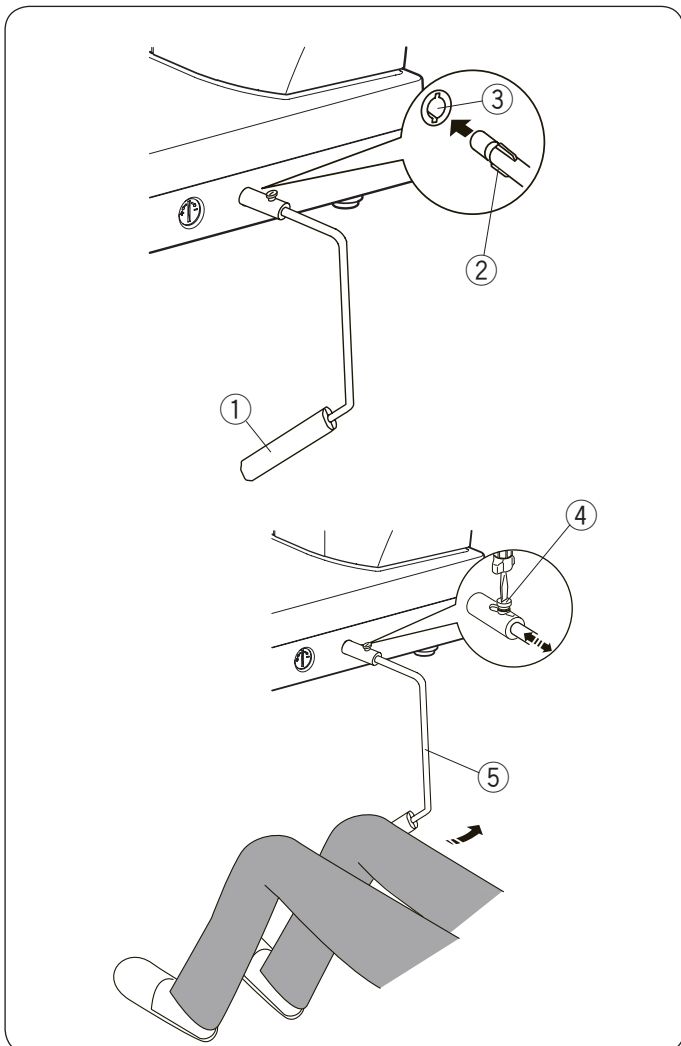

Knee Lifter

The knee lifter is extremely helpful when sewing patchwork, quilting etc, since it allows you to handle the fabric while your knee controls the presser foot.

Attaching the knee lifter

Match the ribs on the knee lifter with the notches in the knee lifter socket and insert the knee lifter.

- ① Knee lifter
- ② Rib
- ③ Knee lifter socket

Adjusting the knee lifter

The angle of the knee lifter can be adjusted to fit you. Loosen the setscrew and slide the angle bar in or out to adjust the angle of the knee lifter.

Tighten the setscrew to secure the angle bar.

- ④ Setscrew
- ⑤ Angle bar

Using the knee lifter

Push the knee lifter with your knee to easily move the presser foot up and down.

You can control how high the foot rises by the amount of knee pressure you exert.

Replacing the Presser Foot

! CAUTION:

Always make sure to press the lockout key to before replacing the presser foot.
Use the proper foot for the selected pattern.
The wrong foot can cause the needle to break.

- 1 Raise the needle by pressing the needle up/down key.
Press the lockout key.

- 1 Needle up/down key
- 2 Lockout key

- 2 Raise the presser foot lifter.

- 3 Presser foot lifter

- 3 Press the black lever on the back of the foot holder.
The presser foot will drop off.

- 4 Lever

! CAUTION:

To avoid damaging the lever, do not push it down.

- 4 Place the presser foot so that the pin on the foot lies just under the groove of the foot holder.

Lower the presser bar to lock the foot in place.
Each foot is marked with an identification letter.

- 5 Pin
- 6 Groove
- 7 Identification letter

1



2

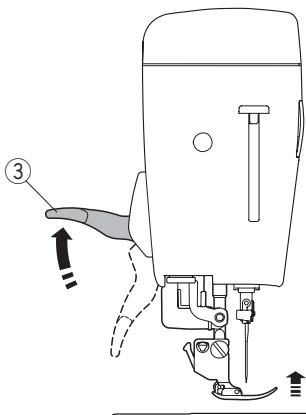

3

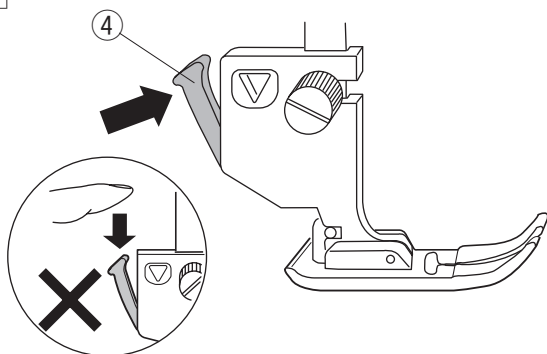

4

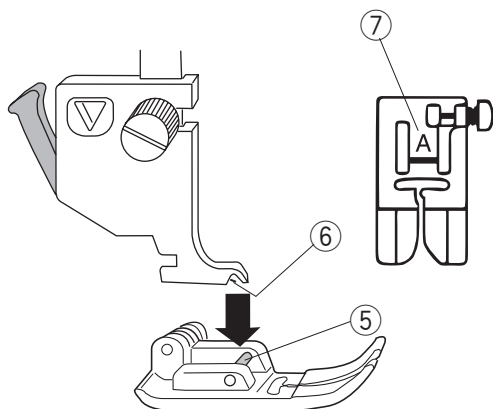

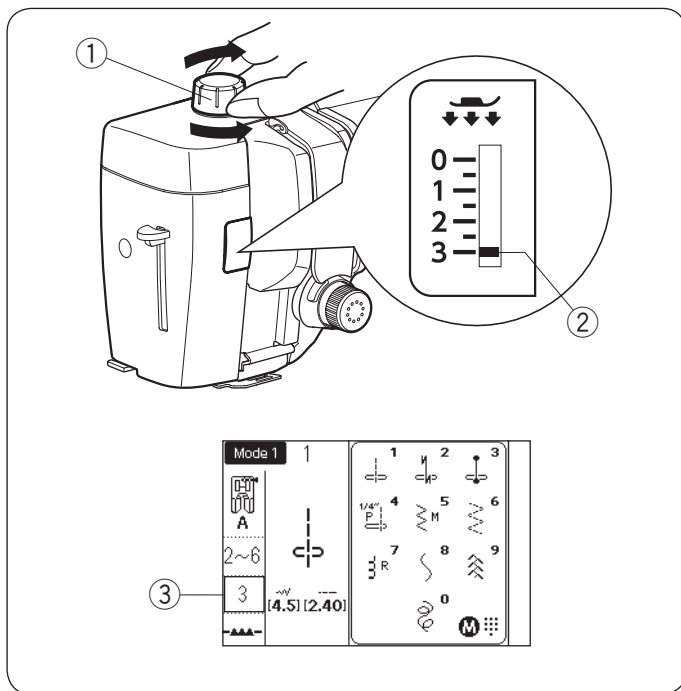

Adjusting the Foot Pressure

The foot pressure dial should be set at “3” for regular sewing.

Reduce the pressure for appliqué, sewing on fine synthetics and elastic fabrics.

Set the dial at “1” when sewing extra fine fabrics.

Consult information on the LCD screen for the recommended foot pressure setting.

- ① Foot pressure dial
- ② Setting mark
- ③ Recommended foot pressure setting

NOTE:

Do not reduce the foot pressure lower than “0”.

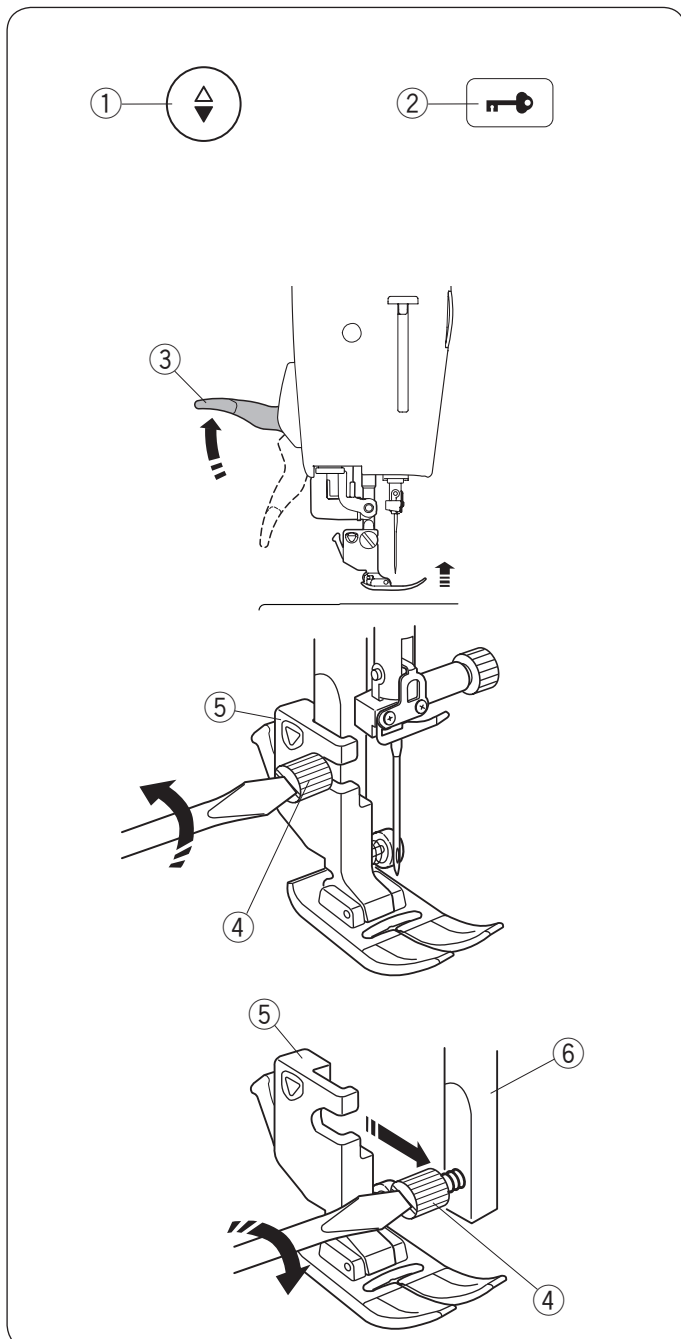

Removing and Attaching the Foot Holder

Remove the foot holder before using Professional grade foot HP, Darning foot PD-H, Convertible free motion quilting foot QB-S, or Dual feed foot AD.

! CAUTION:

Always make sure to press the lockout key to lockout the machine before replacing the foot holder.

Removing the foot holder

Raise the needle by pressing the needle up/down key. Press the lockout key and raise the presser foot with the presser foot lifter.

- ① Needle up/down key
- ② Lockout key
- ③ Presser foot lifter

Loosen the setscrew and remove the foot holder.

- ④ Setscrew
- ⑤ Foot holder

Attaching the foot holder

Attach the foot holder to the presser bar from the rear. Tighten the thumbscrew securely with the screwdriver.

- ⑥ Presser bar

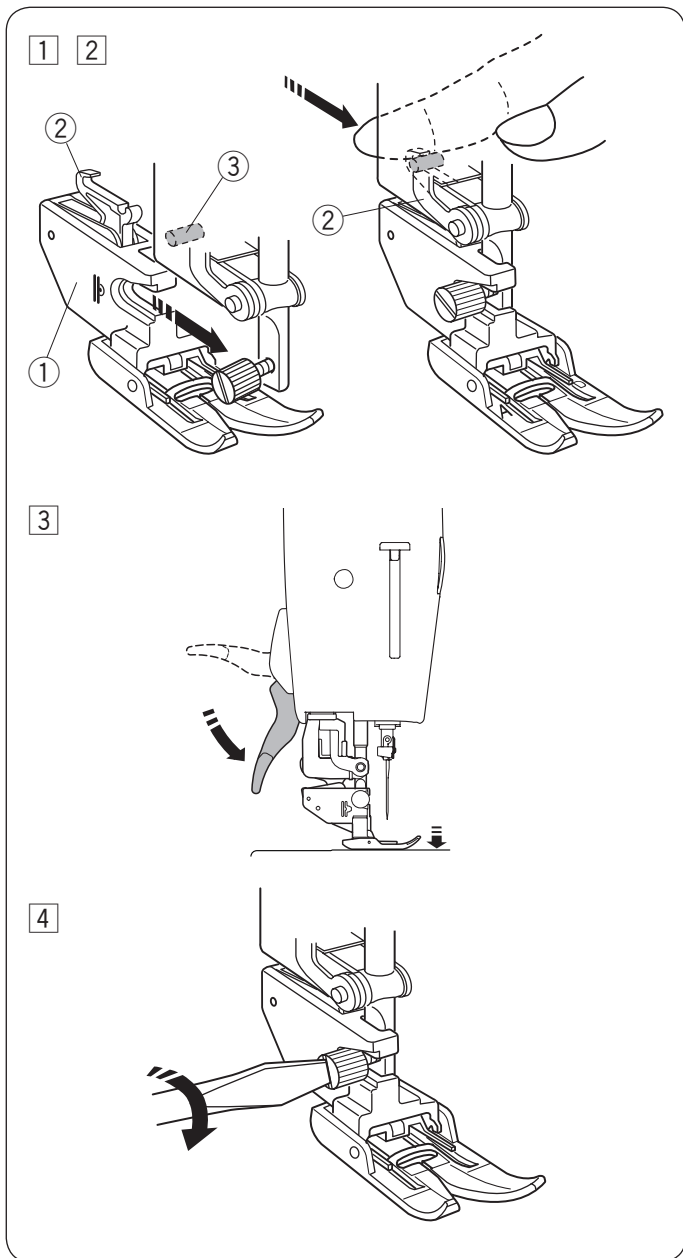

Attaching the Dual Feed Foot AD

- 1 Attach the dual feed holder to the presser bar.
 - ① Dual feed holder
- 2 Tighten the setscrew with your fingers. Push the dual feed link to engage it with upper feed drive.
 - ② Dual feed link
 - ③ Upper feed drive
- 3 Lower the presser foot lifter. Lower the needle to the lowest position by turning the handwheel.
- 4 Tighten the setscrew securely with the screwdriver.

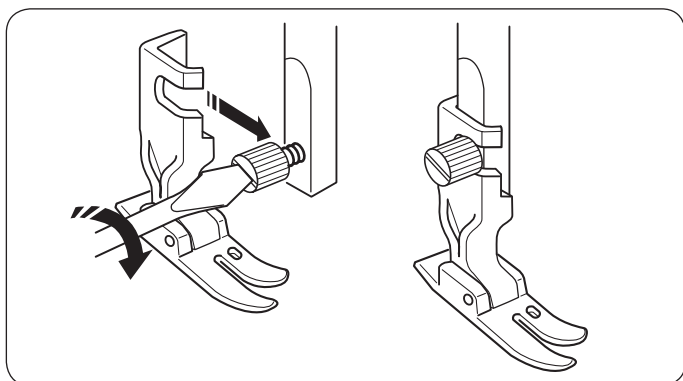

Attaching the Professional Grade Foot HP

Attach the professional grade foot HP to the presser bar. Tighten the setscrew firmly with the screwdriver.

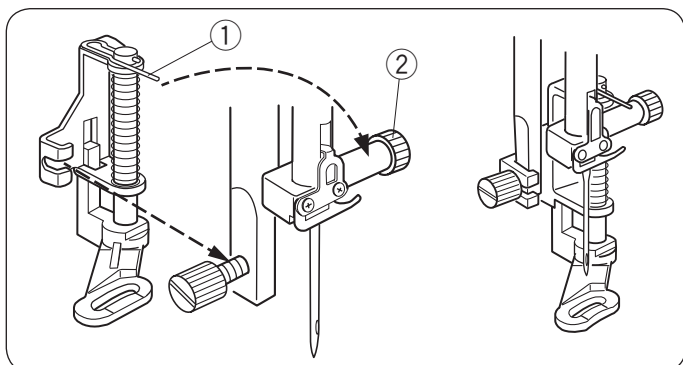

Attaching the Darning Foot PD-H

Attach the darning foot PD-H to the presser bar by putting the pin on the needle clamp screw.

- ① Pin
- ② Needle clamp screw

Tighten the setscrew firmly with the screwdriver.

Replacing Needles

⚠ CAUTION:

Always make sure to press the lockout key to lockout the machine before replacing the needle.

Raise the needle by pressing the needle up/down key. Press the lockout key.

- ① Needle up/down key
- ② Lockout key

Loosen the needle clamp screw by turning it counterclockwise.

Remove the needle from the clamp.

- ③ Needle clamp screw

Insert a new needle into the needle clamp with the flat side of the needle to the rear.

- ④ Flat side

When inserting the needle into the needle clamp, push it up against the stopper pin and tighten the needle clamp screw firmly with a screwdriver.

To check needle straightness, place the flat side of the needle onto something flat (a needle plate, glass etc.). The gap between the needle and the flat surface should be consistent.

- ⑤ Gap

Never use a blunt needle.

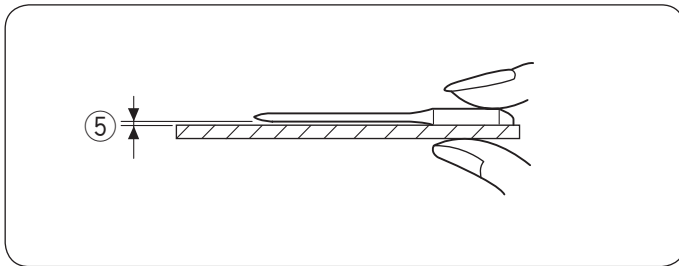
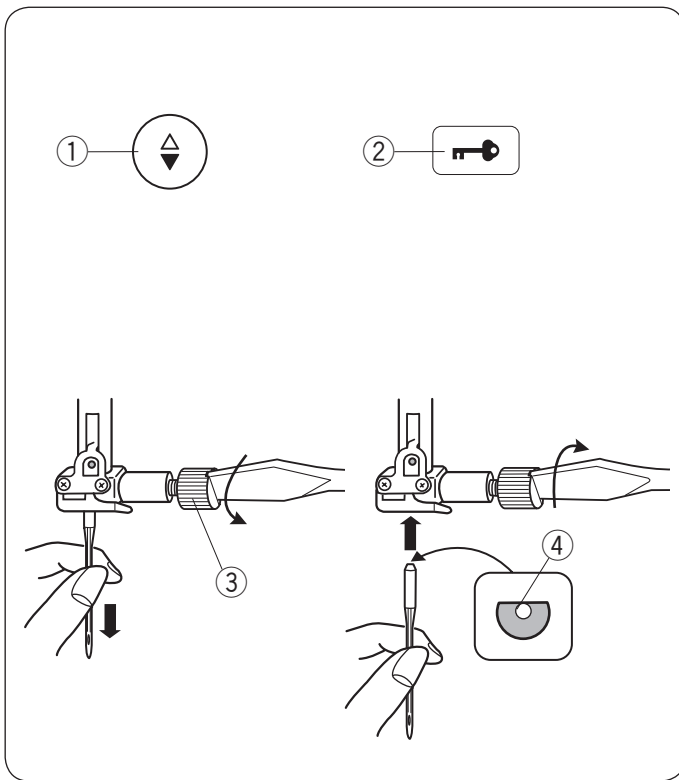

	Fabric	Thread	Needle
Fine	Lawn	Silk #80-100	Blue tip needle
	Georgette	Cotton #80-100	Universal needle
	Tricot	Synthetic #80-100	#9/65-11/75
	Organza Crepe		
Medium	Sheeting	Silk #50	Red tip needle
	Jersey	Cotton #50-80	Purple tip needle
	Broadcloth	Synthetic #50-80	Universal needle
	Fleece		#11/75-14/90
Heavy weight	Denim	Silk #30-50	Red tip needle
	Tweed	Cotton #40-50	Purple tip needle
	Coating	Synthetic #40-50	Universal needle
	Quilting		#14/90-16/100

NOTE:

1 x twin needle, 2 x blue tip needle (#11/75), 1 x red tip needle (#14/90) and 1 x purple tip needle (#14/90) are included in the needle case (Part No. 859856005).

Fabric and Needle Chart

- For general sewing, use red tip needle.
- Fine threads and needles should be used for sewing fine fabrics.
- In general, use the same thread for both needle and bobbin.
- Use a blue tip needle for sewing fine fabrics, stretch fabrics, tricot and buttonholes to prevent skipped stitches.
- Use a purple tip needle for sewing knits, free quilting and across the hem to prevent skipped stitches.
- Use a stabilizer or interface to stretch or fine fabrics to prevent seam puckering.
- Always test the thread and needle size on a small piece of the same fabric you will use for actual sewing.

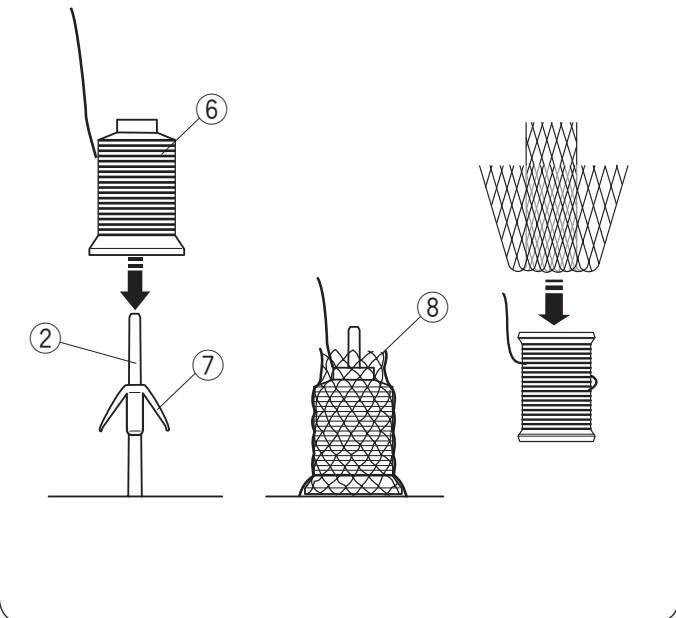
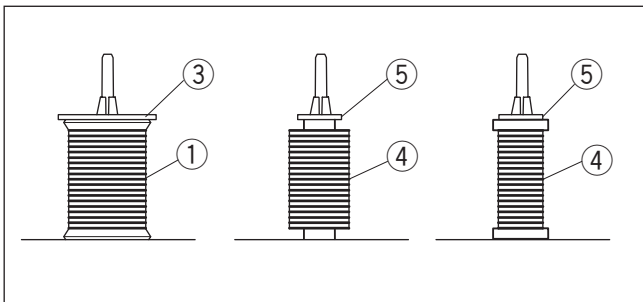
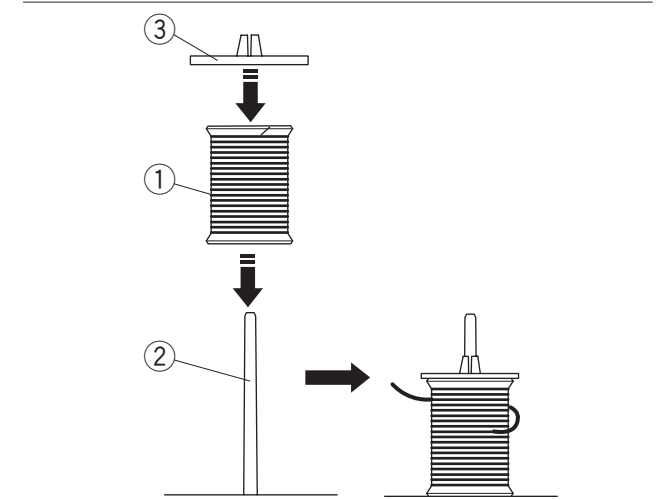
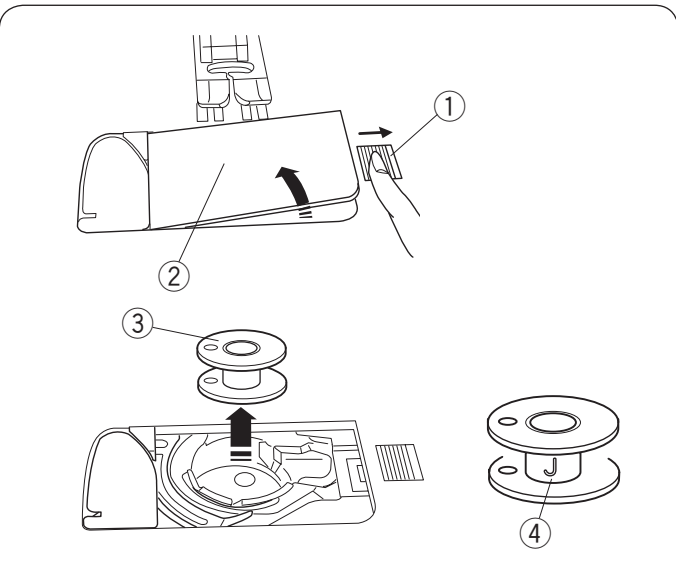

Winding the Bobbin

Removing the bobbin

Slide the hook cover release button to the right, and remove the hook cover plate.

- ① Hook cover release button
- ② Hook cover plate

Lift out the bobbin from the bobbin holder.

- ③ Bobbin

NOTE:

Use the "J" plastic bobbins for horizontal hook (marked with "J" ④). Using other bobbins, such as pre-wound paper bobbins, may cause stitching problems and/or damage to the bobbin holder.

Setting the spool of thread

Place the spool of thread on the spool pin with the thread coming off the spool as shown.

Attach the spool holder, and press it firmly against the spool of thread.

- ① Spool of thread
- ② Spool pin
- ③ Large spool holder

Use the large spool holder for ordinary spools, while the small spool holder for small spools.

- ④ Small spool
- ⑤ Small spool holder

NOTE:

Avoid using a paper cored spool when it begins to empty since it will not unwind smoothly. It may cause the thread to bunch or slip when using the auto thread cutter.

Setting the thread cone

Use the spool rest and the spool net for thread cones.

Attach the spool rests on the spool pin.

Place the spool cone on the spool pin.

Cover the thread cone with the spool net if the thread is shaky or kinky when sewing.

If the net is too long for a spool, fold the net and place it on the spool.

- ② Spool pin
- ⑥ Thread cone
- ⑦ Spool rest
- ⑧ Spool net

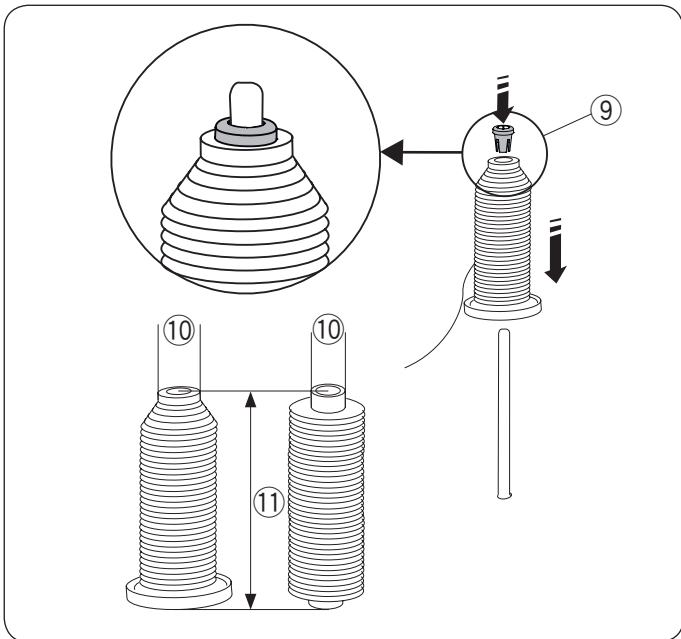

Setting the spool of thread or thread cone (special size)

Use the spool holder (special) to hold the specific size of the spool of threads as shown.

The sizes of the spools of thread are as follows; The hole diameter of the spool has a range of 3/8" to 7/16" (9.5 to 10.5 mm), and the spool length has a range of 2 3/4" to 3" (70 to 75 mm).

- ⑨ Spool holder (special)
- ⑩ Hole diameter (3/8" to 7/16")
- ⑪ Spool length (2 3/4" to 3")

Firmly insert the spool holder (special) into the hole and hold the spool as illustrated.

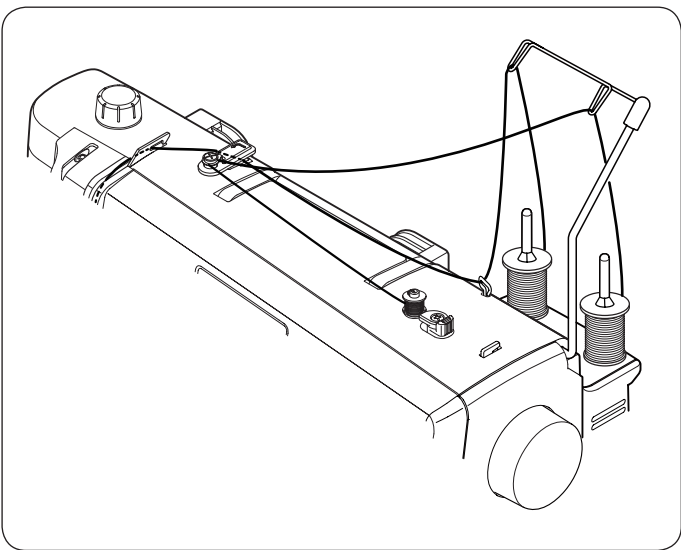

Bobbin winding while working on a sewing project

There are 2 spool pins on the spool stand.

You can use both spool pins when you need to wind a bobbin without unthreading the machine while working on a sewing project.

Place a spool of thread on the spool pin and fix the spool with the spool holder as shown.

NOTE:

Those spool pins are also used for twin needle sewing (refer to page 80).

Winding the bobbin

NOTE:

You can adjust the bobbin winding speed (refer to page 35).

- 1 Raise the retractable thread guide bar.
Pass the thread through the guide on the thread guide bar from behind.
 - 1 Thread guide bar
- 2 Pass the thread under the bobbin winding tension disk.
 - 2 Bobbin winding tension disk
- 3 Thread through the hole in the bobbin from the inside to the outside.
Put the bobbin on the bobbin winder spindle.
Push the bobbin winder stopper to the left.
 - 3 Bobbin winder spindle
 - 4 Bobbin winder stopper
- 4 Hold the free end of the thread in your hand and press the bobbin winding key.
Press the bobbin winding key again to stop the bobbin when it has wound several layers, and cut the thread close to the hole in the bobbin.
 - 5 Bobbin winding key

NOTE:

When the bobbin winding key is pushed without pushing the bobbin winder stopper to the left, the screen shown left is displayed.
Push the bobbin winder stopper to the left before the winding.

- 5 Press the bobbin winding key again. When the bobbin is fully wound, the machine will stop automatically.
The bobbin winder stopper automatically returns to its original position. Cut the thread.
 - 6 Thread cutter

NOTE:

For safety purposes, the machine will automatically stop 1.5 minutes after starting bobbin winding.

Inserting the Bobbin

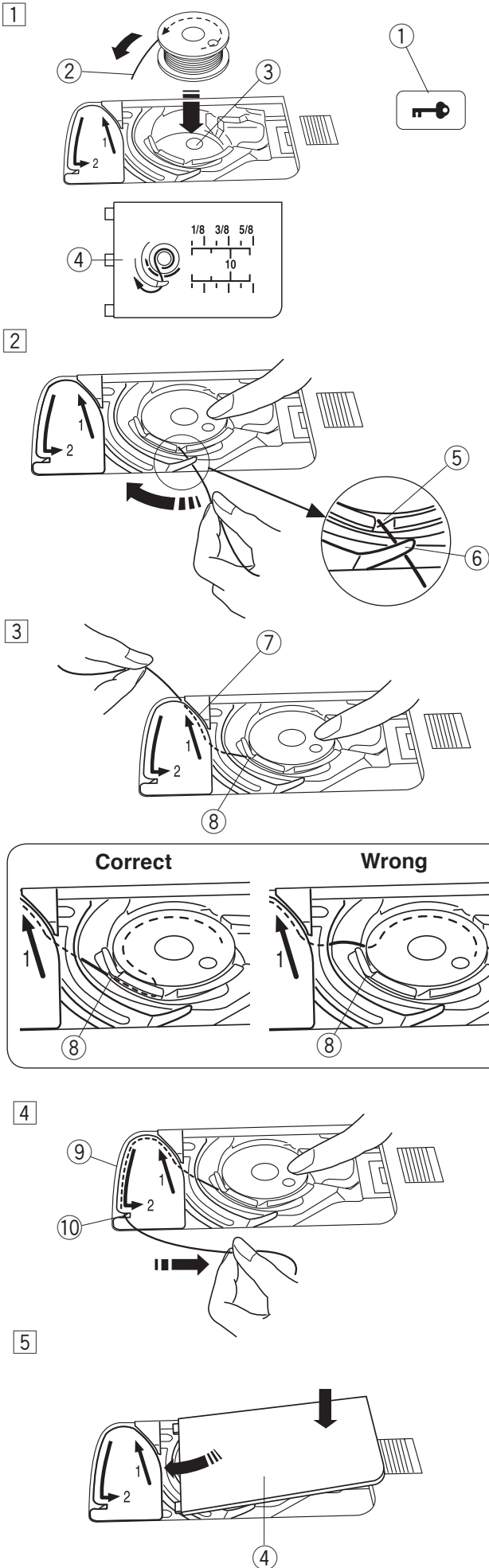

- 1 Press the lockout key.
Place a bobbin in the bobbin holder with the thread running off counterclockwise as shown on the hook cover plate.

- ① Lockout key
- ② End of thread
- ③ Bobbin holder
- ④ Hook cover plate

- 2 Hold the bobbin with your fingertip so it does not rotate.
Guide the thread into the front notch of the bobbin holder.
Pull the thread to the left to pass it under the guide.

- ⑤ Front notch
- ⑥ Guide

- 3 Draw the thread to the left to pass it into the guide path marked "1".
Make sure that the thread comes out from the side notch of the bobbin holder.

- ⑦ Guide path 1
- ⑧ Side notch

NOTE:

If the thread does not come out from the side notch, rethread from step 1.

- 4 Continue to draw the thread along the guide path marked "2" and pull the thread to the right through the slit. The thread will be cut to a proper length and held in place.

- ⑨ Guide path 2
- ⑩ Slit (Thread cutter)

- 5 Set the left edge of the hook cover plate into opening.
Push down the hook cover plate to fit in place.

NOTE:

Unless otherwise noted, you can start sewing without drawing up the bobbin thread.
Refer to page 25 for how to draw up the bobbin thread.

Threading the Machine

! CAUTION:

Always make sure to press the lockout key to lockout the machine before threading the machine.

- 1 Press the needle up/down key to raise the take-up lever to the highest position.

Press the lockout key to lockout the machine.

- ① Needle up/down key
- ② Thread take-up lever
- ③ Lockout key

- 2 Pass the thread through the guide on the thread guide bar from behind.

- ④ Thread guide bar

- 3 Pass the thread through the right thread guide.

- ⑤ Right thread guide

- 4 Hold the upper thread with both hands as shown and slip it under the thread guide plate.

- ⑥ Thread guide plate

- 5 Draw the thread toward you and pass it into the left thread guide.

- ⑦ Left thread guide

- 6 Draw the thread along the right channel, and around the tension dial from the right to the left. Pull the thread up to insert it between the tension disks and under the loop of the check spring.

Be sure that the thread is coming out from notch of the disk.

- ⑧ Right channel
- ⑨ Thread tension dial
- ⑩ Check spring
- ⑪ Notch

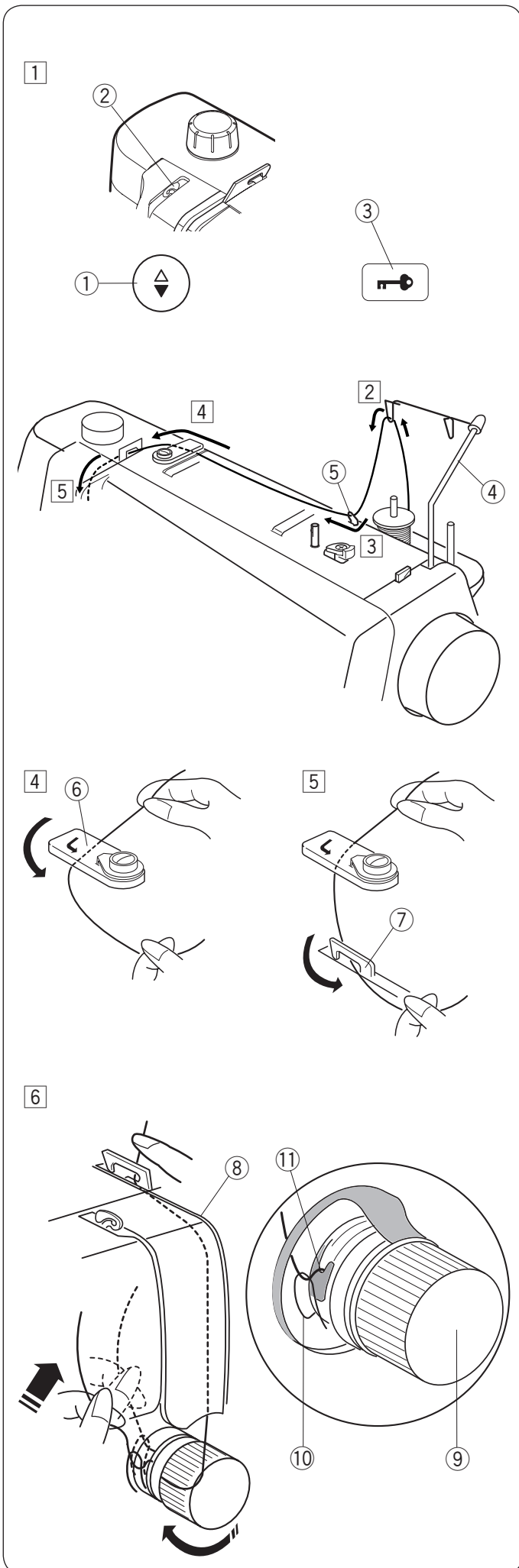

Threading the Machine (Continued)

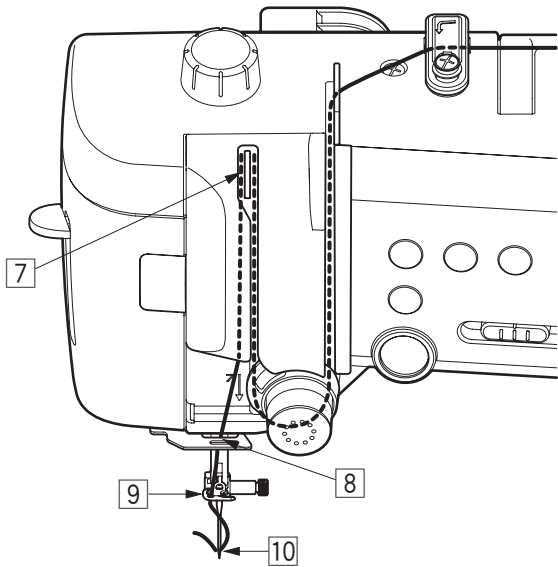

7

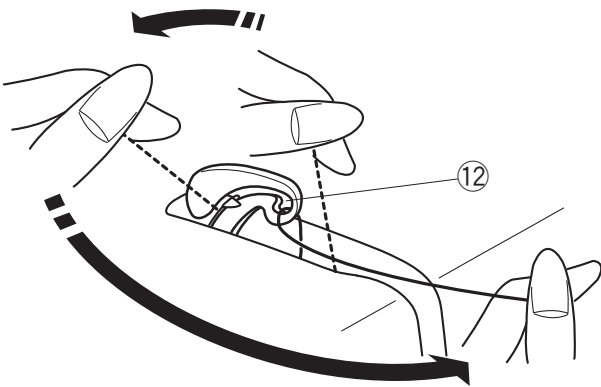

- 7 While holding the thread at the spool, firmly draw the thread up and to the back of the take-up lever. Draw the thread forward to draw it into the eye of the take-up lever.

12 Eye of the take-up lever

8 9

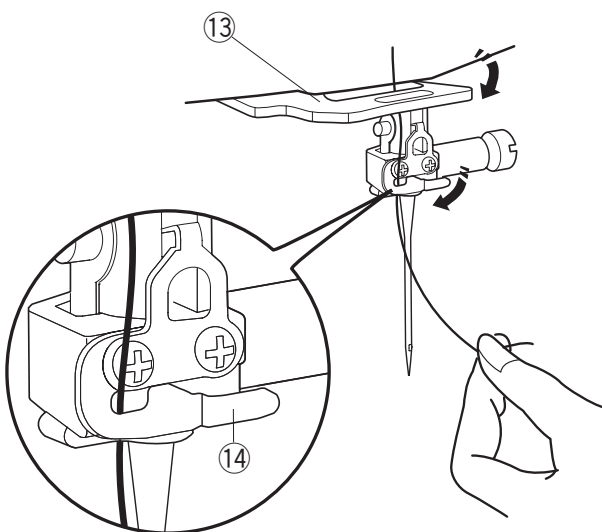

- 8 Then pull the thread down along the left channel and through the lower thread guide.

13 Lower thread guide

- 9 Slide the thread from the right of the needle bar thread guide to the left. Be sure to slide the thread to the end of the slit as shown.

14 Needle bar thread guide

- 10 Thread the needle with the needle threader (refer to the next page).

Built-in Needle Threader

NOTE:

- The needle threader can be used with a #11 to #16 needle.
Thread size 50 to 90 is recommended.
Do not use thread size 30 or thicker.
- The needle threader cannot be used with the twin needle.

- 1 Press the needle up/down key to raise the needle.
Press the lockout key to lock the machine.

- 1 Needle up/down key
- 2 Lockout key

- 2 Draw the thread through the slit ③ of the needle threader. The thread should pass under the hook ④.

- 3 Slit
- 4 Hook

- 3 Pull the thread up and slip it between the thread cutter and face plate from behind.
Pull the thread toward you to cut.

- 4 Pull down the needle threader lever as far as it will go.

- 5 Raise the threader slowly so a loop of the thread is pulled up through the needle eye.

- 6 Pull the thread loop to take the thread end out through the needle eye to the rear.

NOTE:

If the thread is caught in the hook and the thread loop is not formed, remove the thread from the hook and pull it to take the thread end out through the needle eye.

Drawing up the Bobbin Thread

After using auto thread cutting or threading the bobbin holder, you can start sewing without drawing up the bobbin thread.

However, you need to draw up the bobbin thread when sewing gathering stitches etc.

- 1 Remove the bobbin. Insert the bobbin into the bobbin holder again and rethread the bobbin holder according to the instructions on page 21, but leave a 10 cm (4") tail of bobbin thread as shown.

① Bobbin thread

NOTE:

Do not cut the bobbin thread with the thread cutter.

② Thread cutter

- 2 Raise the presser foot. Hold the needle thread lightly with your left hand.

③ Needle thread

- 3 Press the needle up/down key twice to lower and raise the needle and pick up the bobbin thread.

④ Needle up/down key

- 4 Pull both threads 10 cm (4") under and behind the presser foot.

1

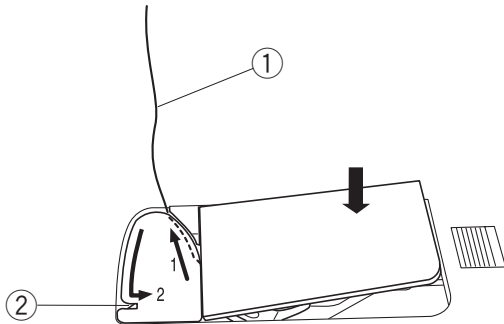

2

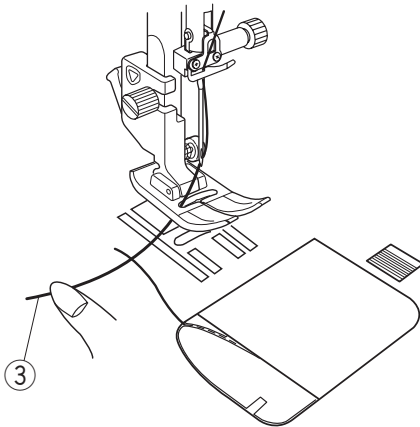

3

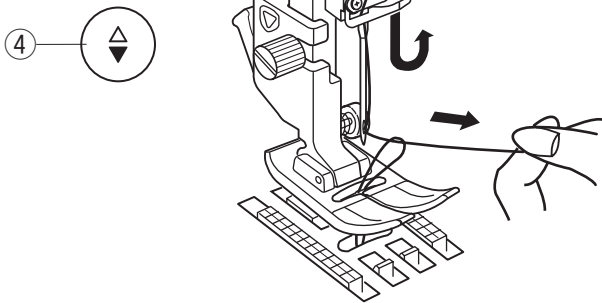

4

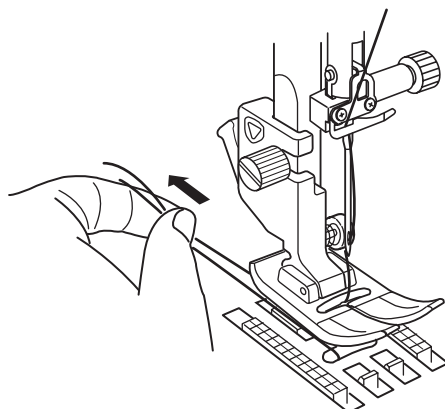

1

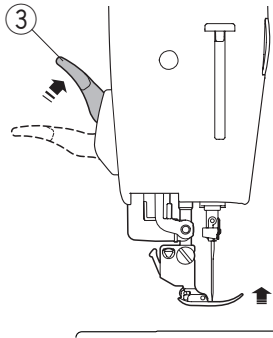

2

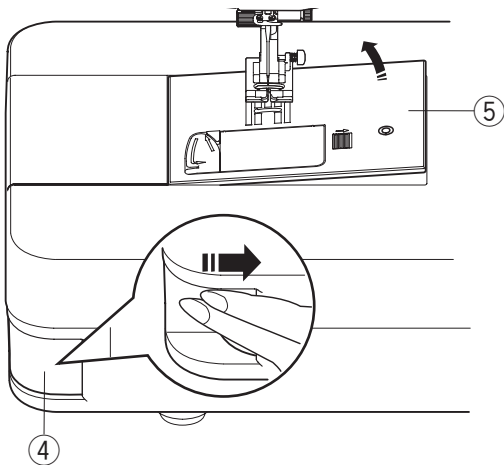

3

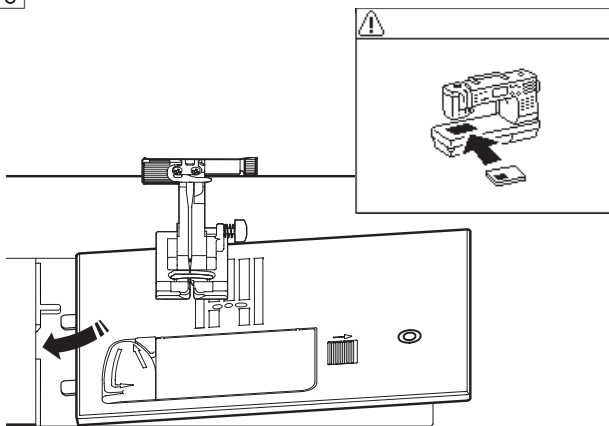

4

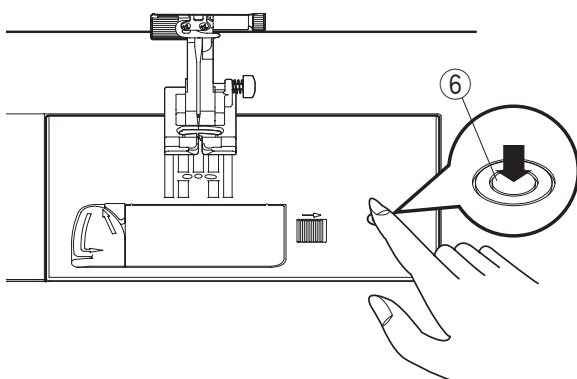

Replacing the Needle Plate

The straight stitch needle plate can be used for straight stitches with the left, center or right needle drop positions. Use the professional grade needle plate HP for the straight stitch with the left needle drop position. Attach the professional grade foot when sewing with the professional grade needle plate HP.

! CAUTION:

Always make sure to press the lockout key to lockout the machine before replacing the needle plate.

NOTE:

When the straight stitch needle plate or the professional grade plate is attached to the machine, the patterns not suitable for the straight stitch needle plate or the professional grade plate cannot be selected.

- 1 Press the needle up/down key to raise the needle. Press the lockout key. Raise the presser foot to the extra lifted position with the presser foot lifter.
 - ① Needle up/down key
 - ② Lockout key
 - ③ Presser foot lifter (extra lifted position)
- 2 Push the needle plate release lever to the right and the needle plate will snap off.
 - ④ Needle plate release lever
 - ⑤ Needle plate
- 3 A message will appear warning that the needle plate is not secured. Remove the needle plate to the right. Place the straight stitch needle plate on the machine. Set the left edge of the needle plate into the opening.

- 4 Push down on the mark of the needle plate until it locks in place. Make sure the warning message disappears and the straight stitch is automatically selected. Turn the handwheel slowly and make sure that the needle does not hit the needle plate. Press the lockout key to unlock.
 - ⑥ Mark

! CAUTION:

Never press the needle plate release lever while running the machine.

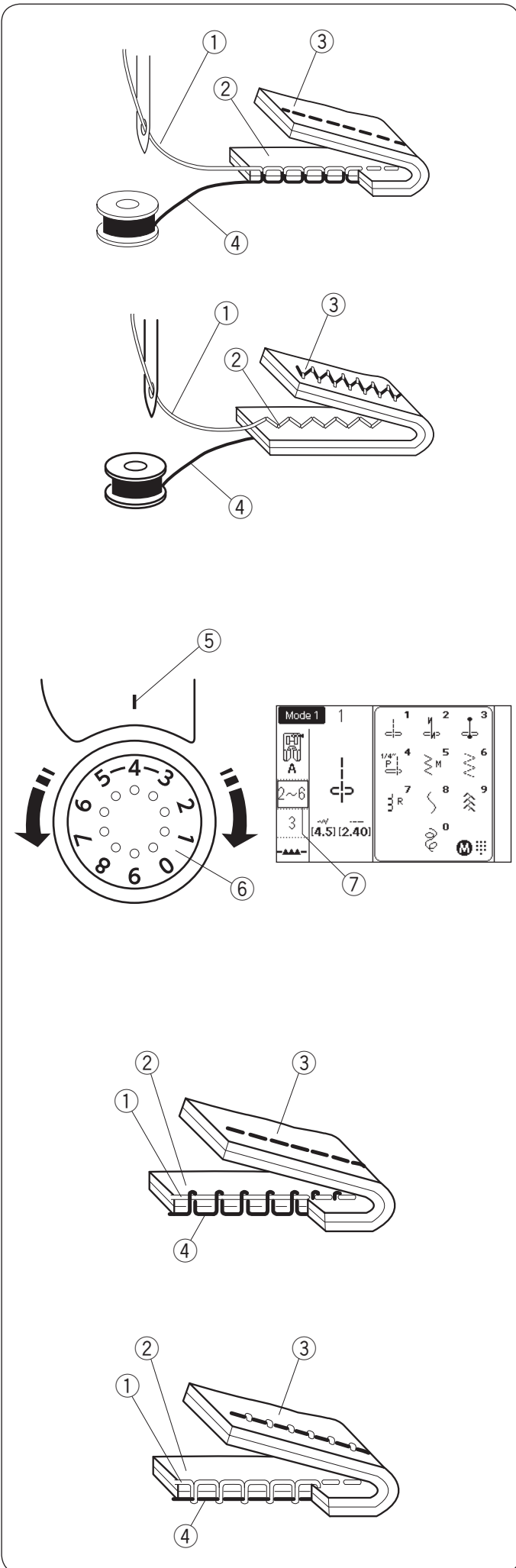

Balancing Thread Tension

Correct tension

The ideal straight stitch has threads locked between two layers of fabric.

- ① Needle thread
- ② Right side of the fabric
- ③ Wrong side of the fabric
- ④ Bobbin thread

For an ideal zigzag stitch, the bobbin thread does not show on the right side of the fabric, and the needle thread shows slightly on the wrong side of the fabric.

Adjusting the tension

Tension adjustment may be needed depending on the sewing materials, layers of fabric and other sewing conditions.

Turn the tension control dial to set the desired number at the setting mark.

Consult information on the LCD screen for the recommended tension setting.

- ⑤ Setting mark
- ⑥ Thread tension dial
- ⑦ Recommended tension setting

Needle thread tension is too tight:

The bobbin thread will appear on the right side of the fabric.

Loosen the needle thread tension by moving the dial to a lower number.

Needle thread tension is too loose:

The needle thread will appear on the wrong side of the fabric.

Tighten the needle thread tension by moving the dial to a higher number.

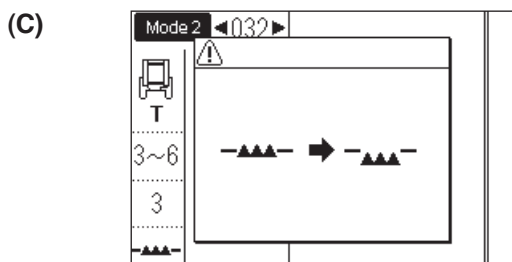
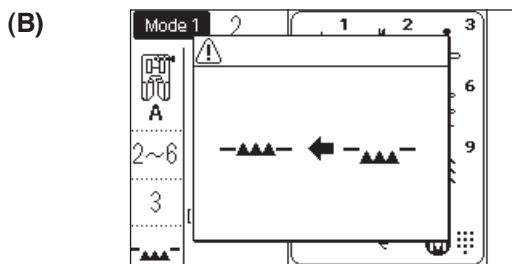
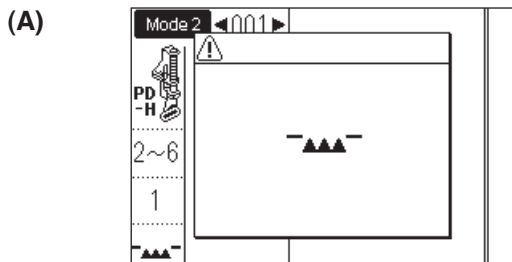
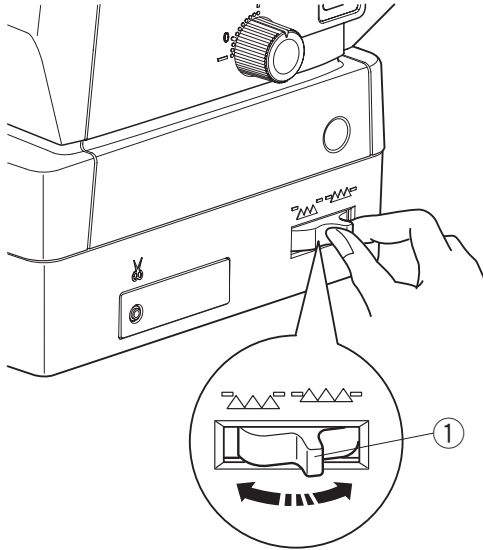
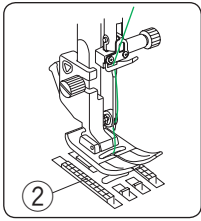

Dropping the Feed Dog

The feed dog can be lowered for sewing on buttons, free motion quilting etc.

Shift the drop feed lever toward you to lower the feed dog.

- ① Drop feed lever
- ② Feed dog

Shift the drop feed lever away from you to raise the feed dog, it will return to the up position when you start the machine.

If you start the machine with the feed dog lowered, a message will appear on the LCD screen.

The message (A) indicates the feed dog has been lowered.

You do not have to raise the feed dog if you do not want to feed the fabric with the feed dog while sewing. Be sure to replace the presser foot to the proper foot.

The message (B) advice you to raise the feed dog. Raise the feed dog and start the machine.

The message (C) advice you to lower the feed dog. Lower the feed dog and start the machine.



CAUTION:

Use the proper foot for the selected pattern.
The wrong foot can cause the needle to break.

Mode 1

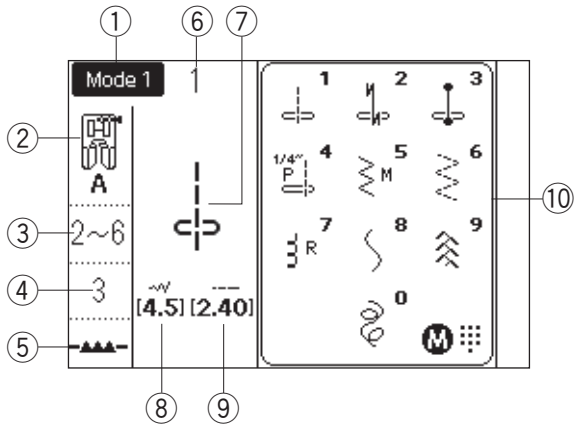

Mode 2, 3

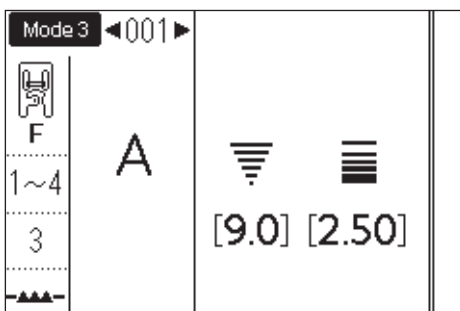
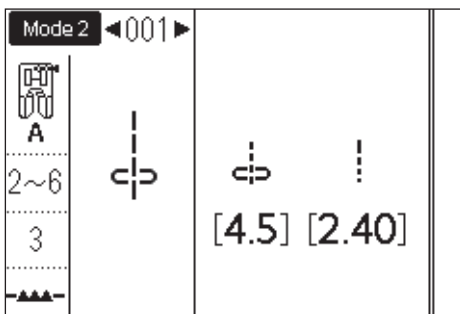
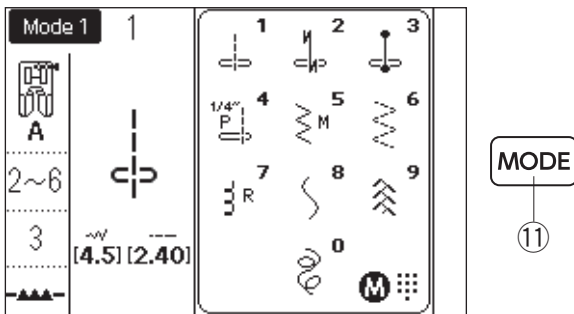
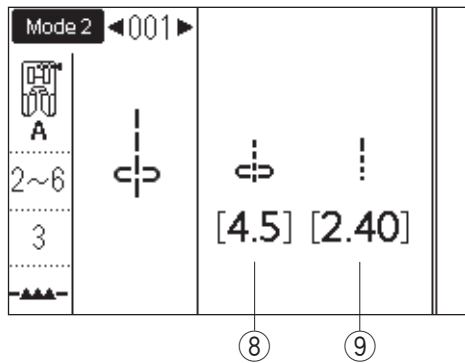

Selecting the Sewing Mode

LCD screen

When the power switch is turned on, the direct pattern selection (mode 1) is set automatically.

On the LCD screen, the mode number and the following information are displayed:

- ① Selected mode or type of attached needle plate
- ② Recommended foot
- ③ Recommended thread tension
- ④ Recommended foot pressure
- ⑤ Feed dog position
- ⑥ Stitch pattern number
- ⑦ Pattern image
- ⑧ Stitch width (or needle drop position)
- ⑨ Stitch length
- ⑩ Direct pattern reference window

Mode selection

Press the mode key to change the mode.

The following 3 sewing modes are available:

- ① Mode key

Mode 1 (Direct pattern selection mode):

The 10 most commonly used stitches can be selected directly. You can also register your favorite stitch pattern to the direct pattern selection (refer to page 31).

Mode 2 (Utility and decorative stitch patterns):

The utility, buttonhole, specialty, decorative stitches and patterns for patchwork quilting are available.

Mode 3 (Monogram):

You can program letters and special characters for monogramming.

NOTE:

When the straight stitch needle plate or the professional grade plate is attached to the machine, the reference chart suitable for the straight stitch needle plate or the professional grade plate will be displayed on the LCD screen. Refer to the pages 41 and 42.

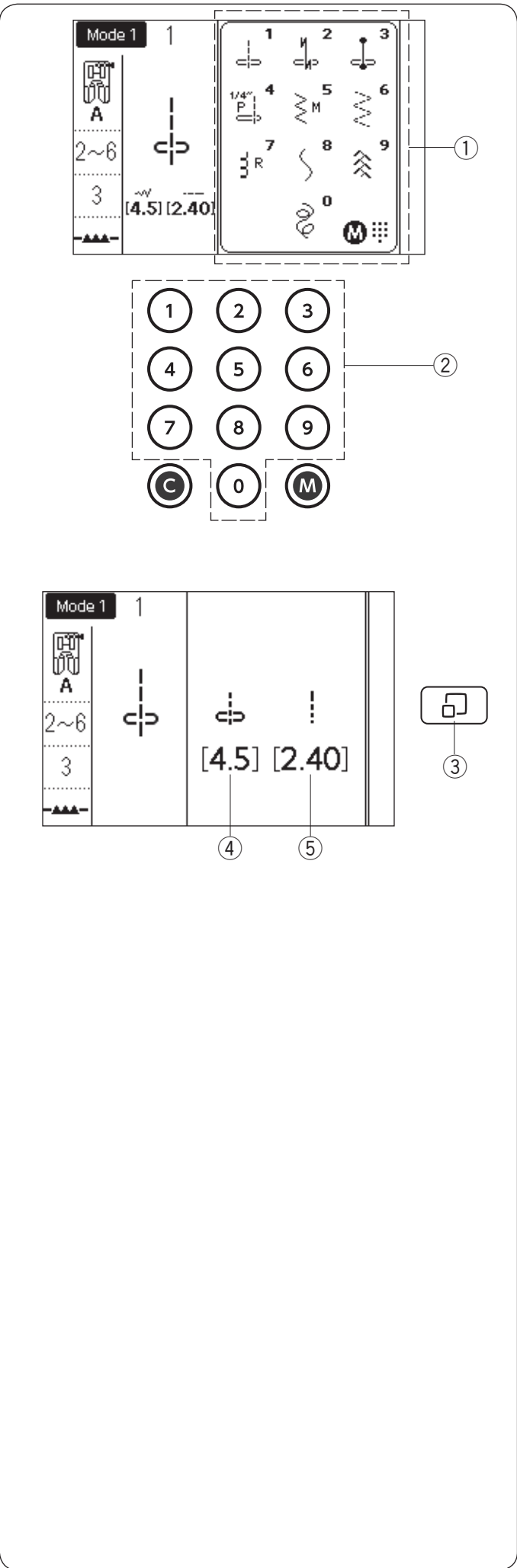

Selecting the Pattern

Mode 1: Direct pattern selection mode

You can select the stitch patterns on the direct pattern reference window by pressing the corresponding numeral keys.

- ① Direct pattern reference window
- ② Numeral keys

Direct pattern reference window

Press the stitch display key to hide the direct pattern reference window. The stitch width and length values are displayed to the right side of the LCD screen.

Press the stitch display key again to show the direct pattern reference window.

- ③ Stitch display key
- ④ Stitch width (or needle drop position)
- ⑤ Stitch length

Customizing direct pattern selection

You can assign your favorite stitch pattern to the direct pattern selection.

NOTE:

- You cannot customize the direct pattern selection if the direct pattern reference chart is hidden. Press the stitch display key to show the reference window ①.
- You can assign the stitch patterns in mode 2 only.

Example: Register stitch pattern "023" to "4" key

- 1 Select mode 1.
Press the memory key.
The direct pattern customize screen appears.
You can assign your favorite stitch pattern to the numeral keys from 4 to 9 and 0.
- 2 Memory key
- 2 Press the desired numeral key to which you want to assign a new stitch pattern. Select from among 4 - 9 and 0 as shown.
Press "4" key.
- 3 Enter the stitch number of the desired stitch pattern.
Press "0", "2" and "3" keys in order.
Press the memory key.

NOTE:

You can also select the desired pattern by turning the jog dials or pressing the arrow keys.

- 4 Press the memory key to assign the stitch pattern.
The stitch pattern image of the direct stitch pattern selection changes.
- 5 Now you can select the assigned stitch pattern (023) by pressing the numeral key (4) when selecting mode 1.

Resetting your direct pattern selection

To reset the customized direct stitch pattern selection, press the memory key.
Press the twin needle key and the confirmation message appears.
Press the memory key.
The direct stitch pattern selection screen changes to the default settings with the beep.
Press the memory key to reset the selection.

- 3 Twin needle key

NOTE:

Be sure to press the memory key again after the beep. Otherwise the direct pattern selection will not reset.

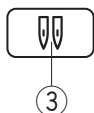
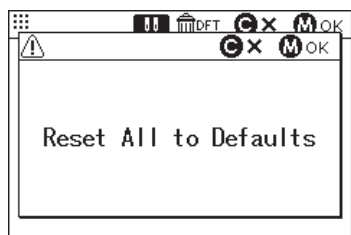
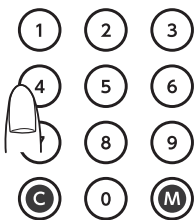
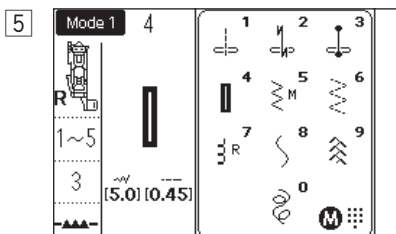
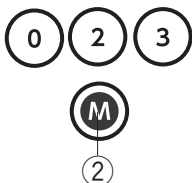
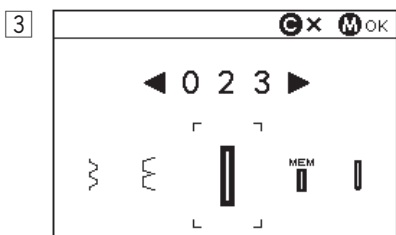
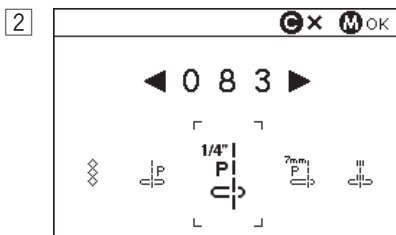
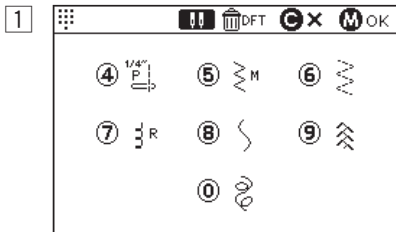
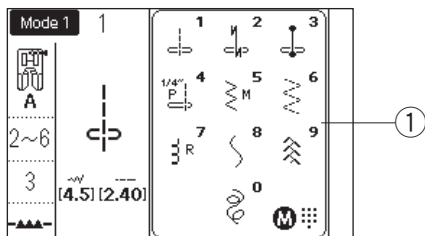

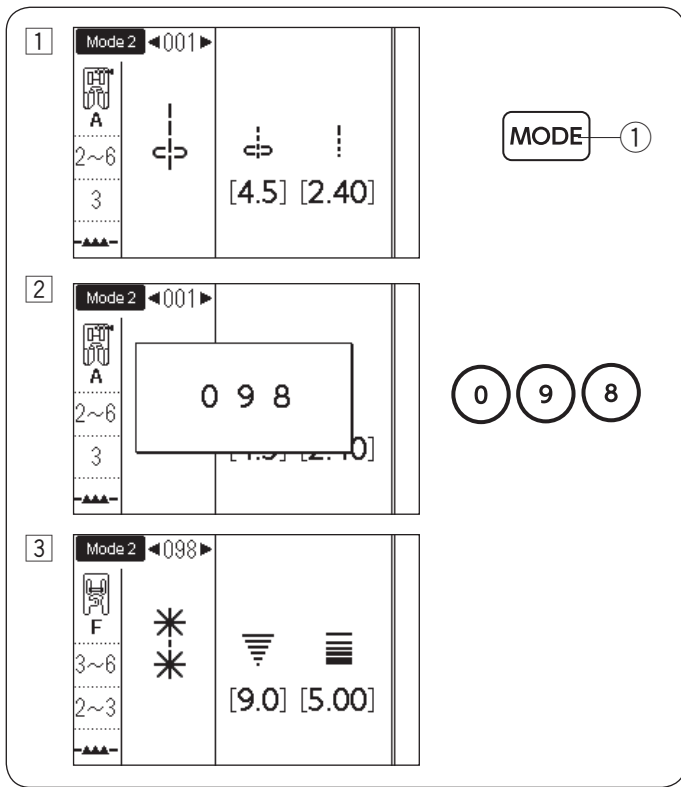

Pattern Selection in Mode 2 and Mode 3

• Using numeral keys

Enter the 3-digit pattern number by pressing the numeral keys to select the desired stitch pattern.

Example: Selecting pattern 098 in mode 2

- 1 Press the mode key to select mode 2.
 - ① Mode key

- 2 Press “0”, “9”, and “8” keys in order.

- 3 The stitch pattern “098” has been selected.

NOTE:

The machine accepts 3-digit numbers only. For example, press “0”, “9” and “8” keys in order when selecting pattern 098. Do not skip “0” and start with “9”.

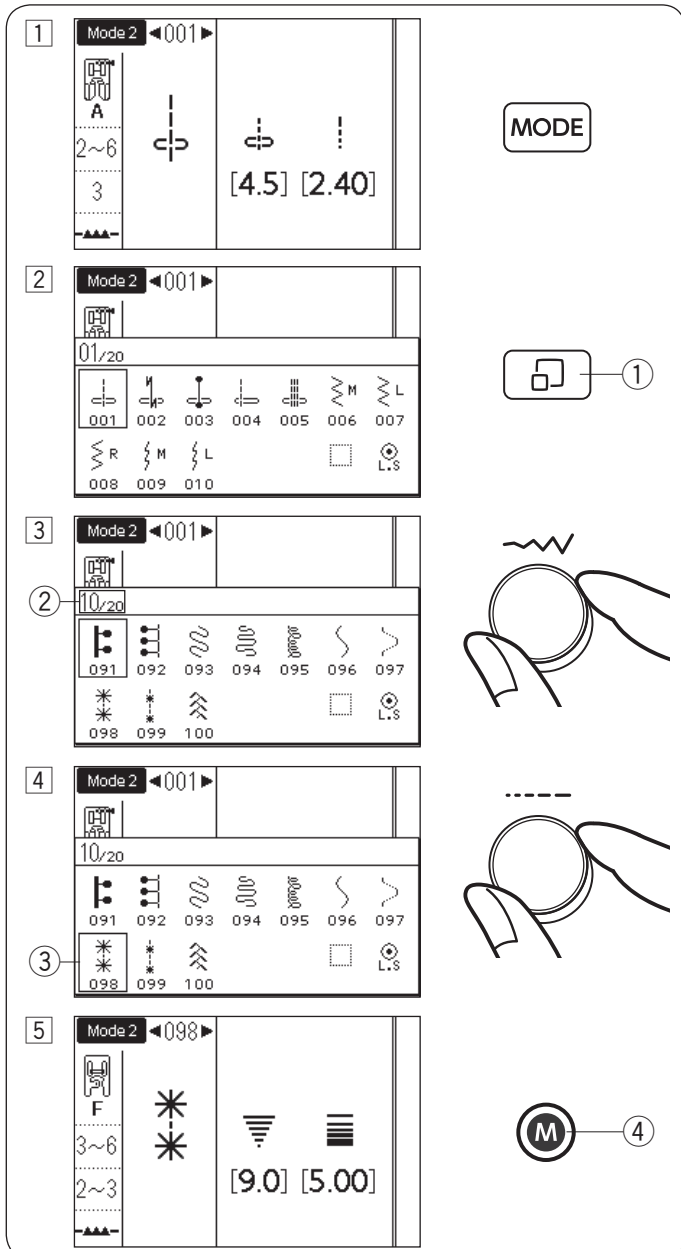

• Using jog dials

You can use jog dials to select your desired patterns.

Example: Selecting pattern 098 in mode 2

- 1 Press the mode key to select mode 2.

- 2 Press the stitch display key and the pattern selection window appears.
 - ① Stitch display key

- 3 To turn the page, turn the stitch width adjusting dial. Turn the dial until the page 10 ② appears.

- 4 To move the cursor left or right, turn the stitch length adjusting dial. Turn the dial until the cursor is at the stitch pattern 098 ③.

- 5 Press the memory key to select the stitch pattern 098.
 - ④ Memory key

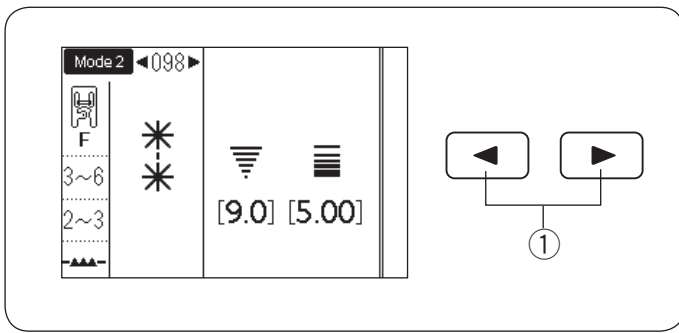

• Using arrow keys

You can use arrow keys to select your desired patterns in mode 2 or 3.

Press the mode key to select the mode 2 or 3.

To select the desired stitch pattern, press the arrow keys until the desired pattern is displayed.

- ① Arrow keys

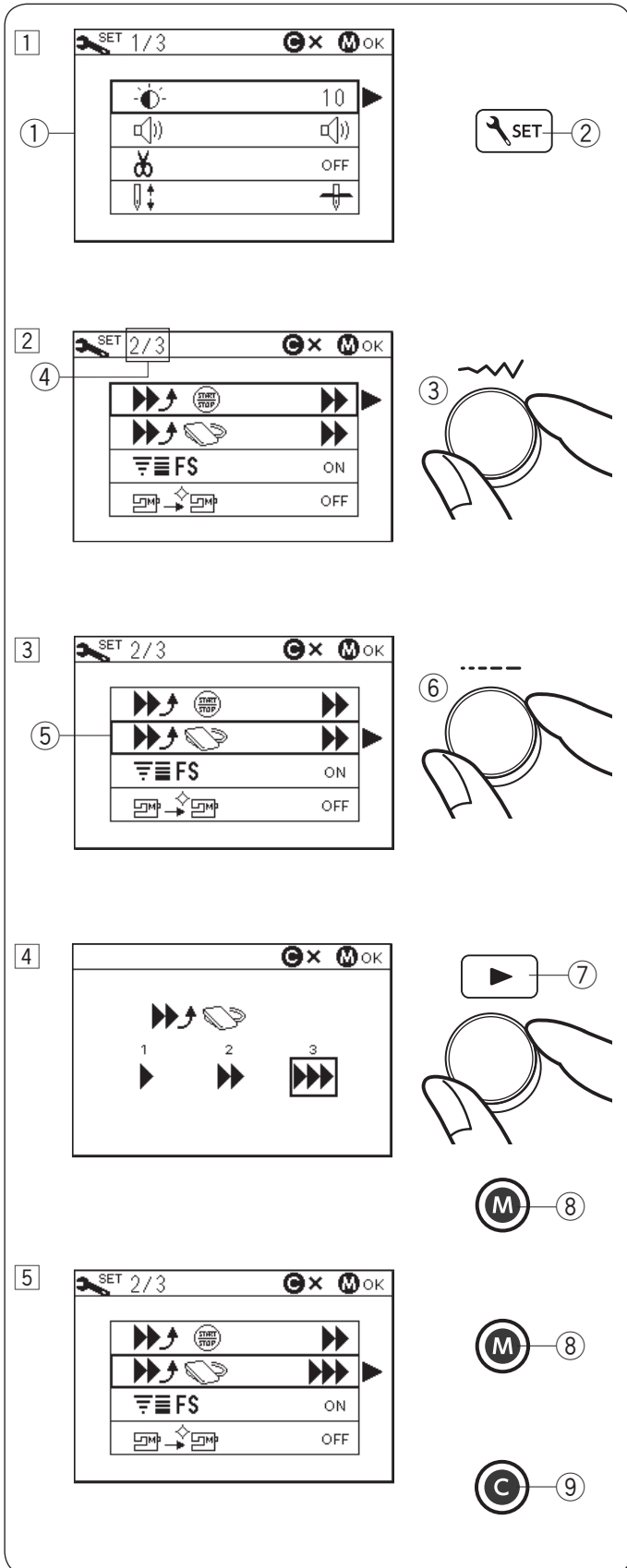

Customizing Machine Settings

You can customize the machine settings to your preference.

Example: Changing the foot control start-up speed

① Press the set key and the LCD screen will show the machine setting mode.

- ① Machine setting mode
- ② Set key

② To turn the page, turn the stitch width adjusting dial. The page number will be indicated upper left corner of the LCD screen.

- ③ Stitch width adjusting dial
- ④ Page number

③ To move the cursor (the bold rectangle on the cell) up or down, turn the stitch length adjusting dial.

- ⑤ Cursor
- ⑥ Stitch length adjusting dial

④ Press the right arrow key to enter the desired setting. Turn the either of the jog dials to move the cursor and select the desired setting.

Press the memory key to set the change.

- ⑦ Right arrow key
- ⑧ Memory key

⑤ To continue machine settings, return to procedure ② and select the other settings.

To finish and apply the settings, press the memory key ⑧. The machine setting mode will be closed and the change of the settings will apply.

To cancel the machine setting mode, press the clear key ⑨. The machine setting mode will be closed and changes of machine settings will not apply.

- ⑨ Clear key

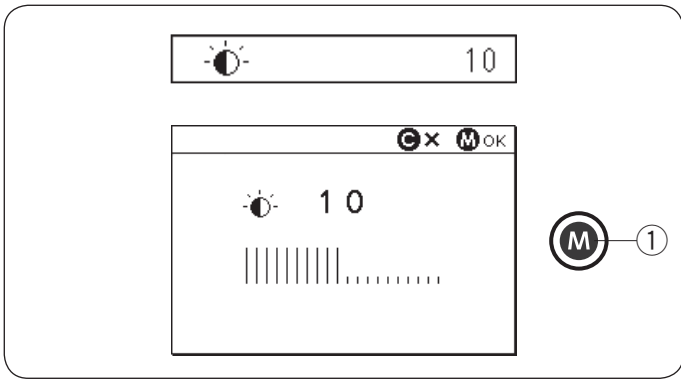

Screen brightness (page 1/3)

The screen brightness can be adjusted from level 0 to 20. The preset level is 10.

Turn the jog dial or press the arrow keys to adjust the screen brightness.

Press the memory key to set the change.

① Memory key

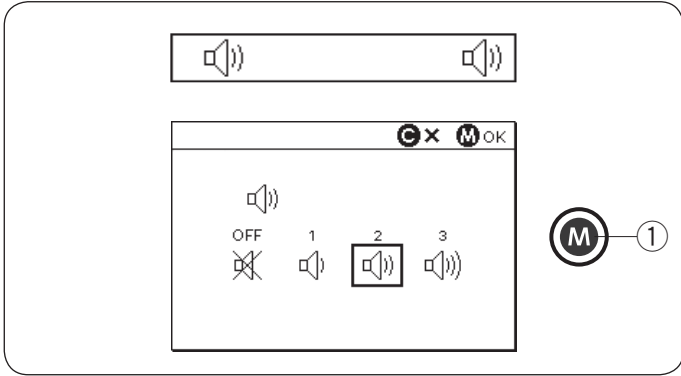

Buzzer sound (page 1/3)

The level of the buzzer sound can be adjusted and you can mute the buzzer in normal operation.

Turn the jog dial or press the arrow keys to select the desired sound level; mute (OFF), low (1) normal (2) or loud (3).

Press the memory key to set the change.

① Memory key

NOTE:

Caution buzzer cannot be turned off.

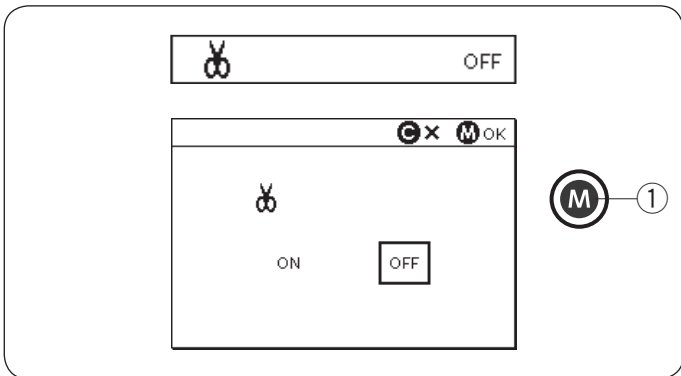

Auto thread cutting (page 1/3)

To cut the threads automatically after locking stitches, turn on the auto thread cutting.

When the auto-thread cutting function is turned on, the thread cutter mark appears on the upper right corner of the LCD screen.

Press the memory key to set the change.

① Memory key

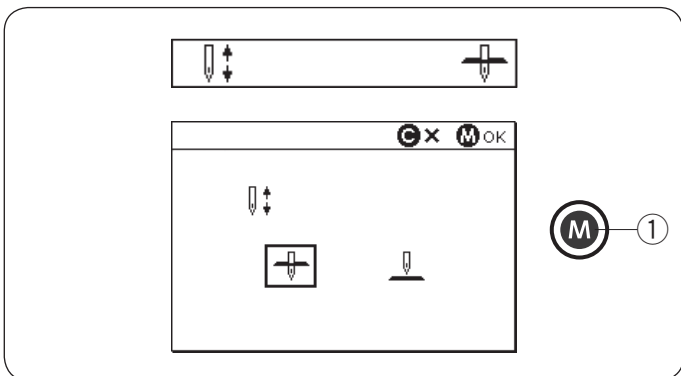

Needle stop position (page 1/3)

The machine always stops with the needle in the down position except when sewing buttonholes, specialty stitches, monograms, etc. However, you can select the needle stop position to up or down.

Turn the jog dial or press the arrow keys to select down or up position.

Press the memory key to set the change.

① Memory key

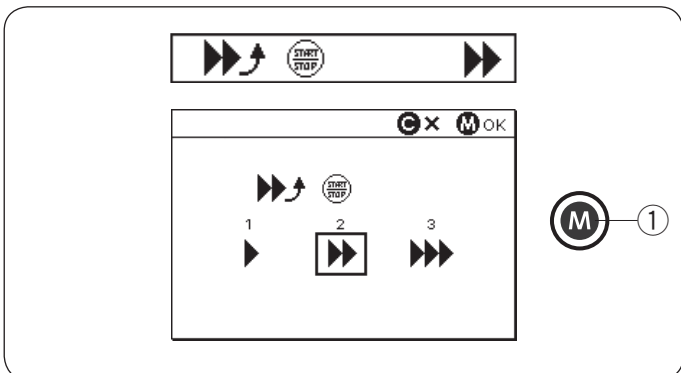

Adjustable start-up speed (START/STOP key) (page 2/3)

The machine will start running slowly and the sewing speed will gradually increase to maximum when pressing the start/stop key.

You can select the desired start-up speed from slow (1), normal (2) or high (3).

Turn the jog dial or press the arrow keys to select the speed.

Press the memory key to set the change.

① Memory key

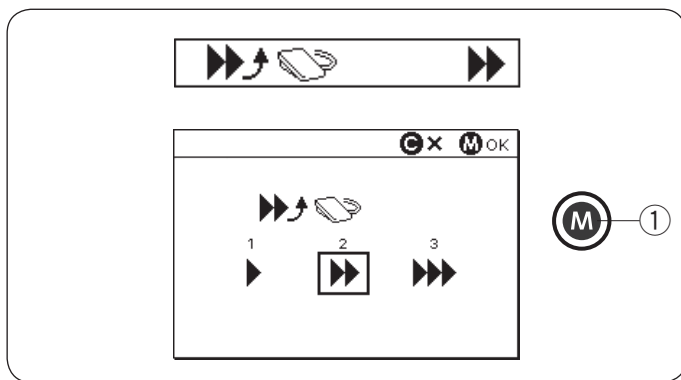

Adjustable start-up speed (Foot control) (page 2/3)
 The machine will start running slowly and the sewing speed will gradually increase to maximum when pressing the foot control.
 You can select the desired start-up speed from slow (1), normal (2) or high (3).
 Turn the jog dial or press the arrow keys to select the speed.
 Press the memory key to set the change.
 ① Memory key

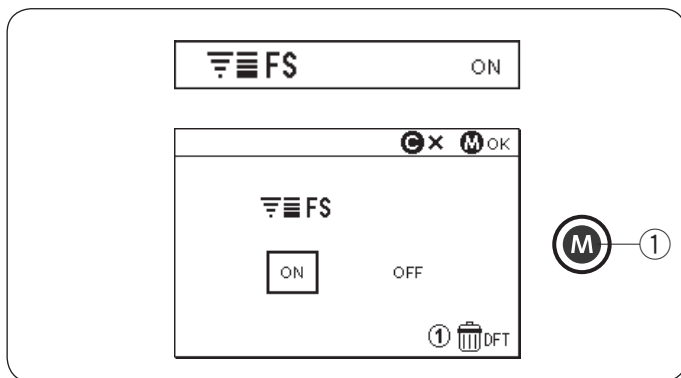

Favorite stitch adjustment (FS) (page 2/3)
 If you want to save the changes to manual stitch settings, turn on this option by turning the jog dials or pressing the arrow keys.
 If this option is turned off, the manual stitch setting will be cleared when the power switch is turned off.
 Press the numeral key "1" and the memory key to clear the all manual stitch settings.
 Press the memory key to set the change.
 ① Memory key

NOTE:
 Favorite stitch option cannot be used in monogram mode (mode 3).

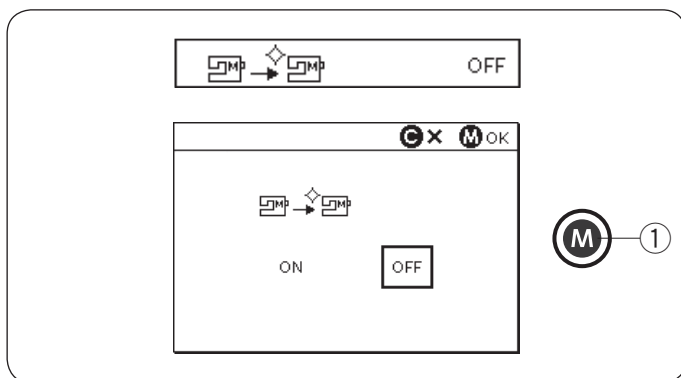

Resume setting (page 2/3)
 Turn on this option when you want to resume the last pattern sewn before turning the power switch off.
 Turn on this option by turning the jog dials or pressing the arrow keys.
 Press the memory to set the change.
 When the power is turned on again, the confirmation message will appear. Press the memory key to resume the last pattern.
 ① Memory key

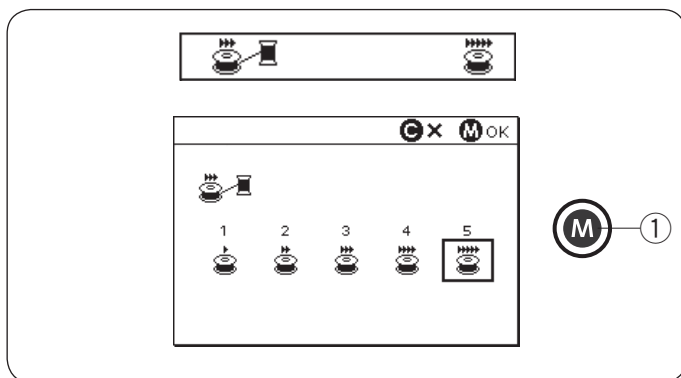

Bobbin winding speed (page 3/3)
 The bobbin winding speed can be adjusted from 1 to 5. The preset speed is 5.
 Turn the jog dial or press the arrow keys to adjust the bobbin winding speed.
 Press the memory key to set the change.
 ① Memory key

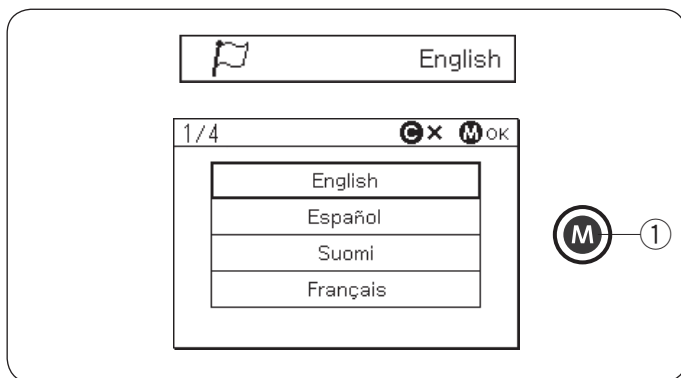

Language selection (page 3/3)
 You can choose one of the following 15 languages for screen display.

- English
- French
- Dutch
- Swedish
- Danish
- Spanish
- German
- Portuguese
- Polish
- Norwegian
- Finnish
- Italian
- Russian
- Turkish
- Japanese

Turn the jog dials or press the arrow key to select the desired language.
 Press the memory key to set the change.
 ① Memory key

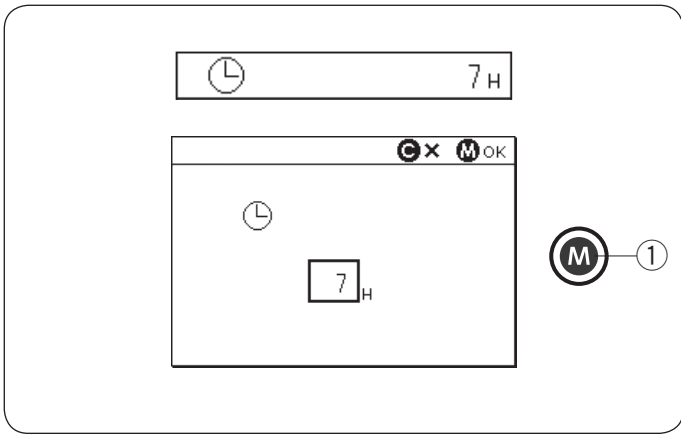

Auto-off timer (page 3/3)

The machine will be automatically turned off if you do not use the machine within the time period set by this timer. The auto-off timer can be set from 1 to 12 hours. If you want to turn off the timer, turn the jog dials or press and hold the arrow key until "OFF" shows in the timer window.

Press the memory key to set the change.

To turn on the machine again, turn the power switch on.

① Memory key

NOTE:

The auto-off timer is available in EU countries and some regions which use 200 - 240 voltage standards.

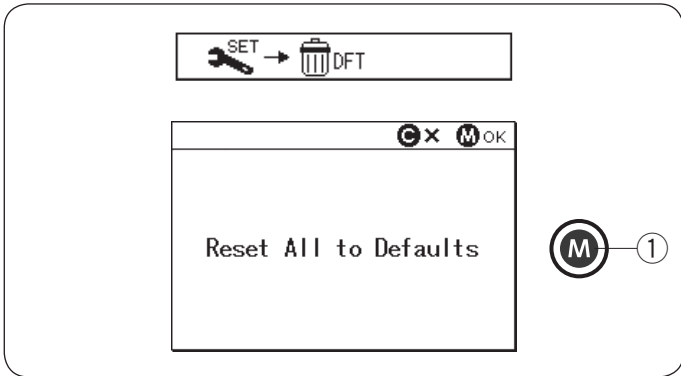

Reset all to default (page 3/3)

The following customized settings can be reset to the original settings (factory settings).

- Screen brightness
- Buzzer sound
- Auto thread cutting
- Needle stop position
- Adjustable start-up speed (START/STOP key)
- Adjustable start-up speed (Foot control)
- Favorite stitch adjustment (ON/OFF)
- Resume setting
- Bobbin winding speed
- Auto-off Timer

Meanwhile, the following settings remain the same;

- Language selection
- Saved favorite stitch adjustment values

The confirmation message appears.

Press the memory key to reset all the settings above to default.

① Memory key

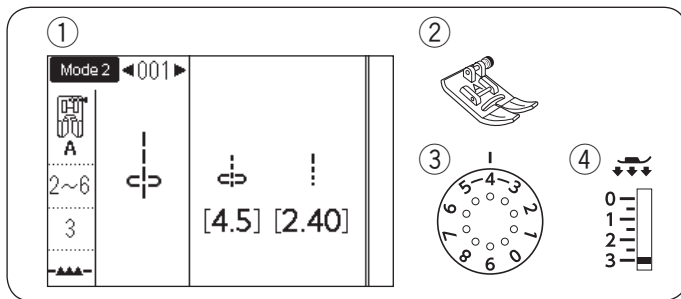

BASIC SEWING

Straight Stitch

- | | |
|-------------------|--------------------------|
| ① Pattern: | MODE 1: 1
MODE 2: 001 |
| ② Presser foot: | Zigzag foot A |
| ③ Thread tension: | 2-6 |
| ④ Foot pressure: | 3 |

Starting to sew

Raise the presser foot and position the fabric edge next to a seam guide on the needle plate. Lower the needle at the point where you want to start.

Pull the needle thread toward the rear.
Lower the presser foot.

NOTE:

Pull the needle thread to the left when using satin stitch foot F, open-toe satin stitch foot F2, dual feed foot or automatic buttonhole foot R.

Press the start/stop key or foot control to start sewing.
Gently guide the fabric along the seam guide line letting the fabric go naturally.

- ① Start/stop key

Sewing from the Edge of Thick Fabric

The black button on the zigzag foot locks the foot in the horizontal position.

This is helpful when you start sewing at the extreme edge of thick fabrics or for sewing across a hem.

Lower the needle into the fabric at the point where you want to start sewing.

Lower the foot while pushing in the black button. The foot is locked in the horizontal position to avoid slipping.

After a few stitches, the black button is released automatically.

- ② Black button

Changing Sewing Direction

Stop the machine and raise the presser foot lifter to raise the presser foot.

Pivot the fabric around the needle to change the sewing direction as desired.

Start sewing in a new direction.

Turning a Square Corner

To maintain a 5/8" seam allowance after turning a square corner, use the cornering guide on the needle plate.

Stop sewing when the front edge of fabric reaches the cornering guide lines.

Raise the presser foot and turn the fabric 90 degrees.

Start sewing in the new direction.

- ③ Cornering guide

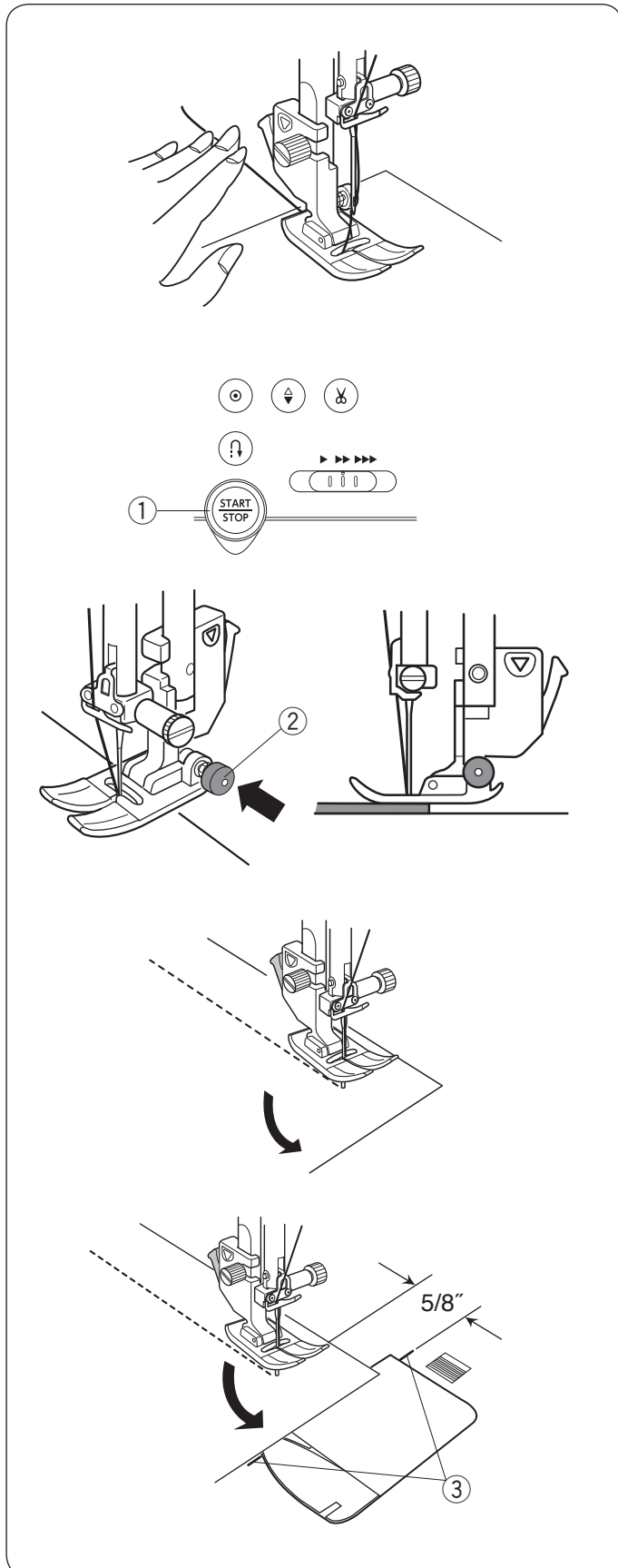

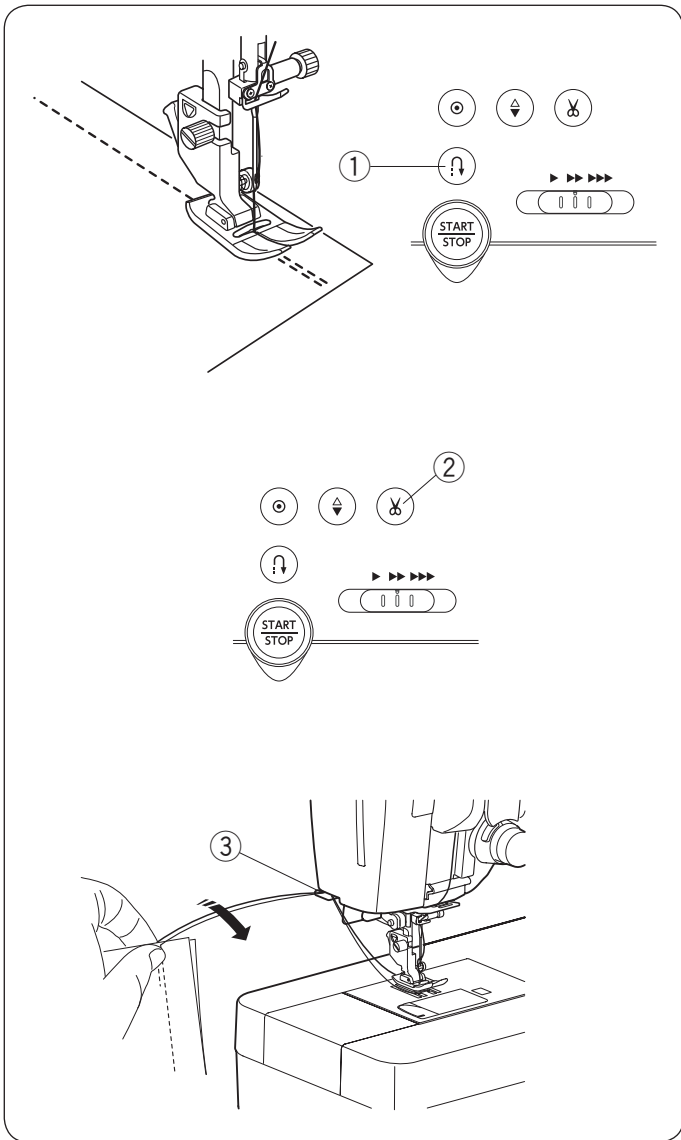

Securing Seams

For fastening the ends of seams, press the reverse key and sew several reverse stitches.

The machine sews in reverse as long as you press and hold the reverse key.

- ① Reverse key

Press the reverse key once when sewing the lock-a-matic stitch (pattern 002 in mode 2) or locking stitch (pattern 003 in mode 2) and the machine will lock the stitches off and stop automatically.

Cutting Threads

To cut the threads after finishing sewing, press the thread cutter key. The needle bar automatically rises after trimming the threads.

- ② Thread cutter key

NOTE:

If you press the thread cutter key with the presser foot up, the LCD screen will advise you to lower the presser foot.

Lower the presser foot and press the thread cutter key.

Use the thread cutter on the face plate to cut specialized or thick threads if the auto thread cutter does not work well.

To use the thread cutter on the face plate, remove the fabric and draw it to the back.

Pull the threads up and slip them between the thread cutter and face plate from behind.

Pull the threads toward you to cut.

- ③ Thread cutter

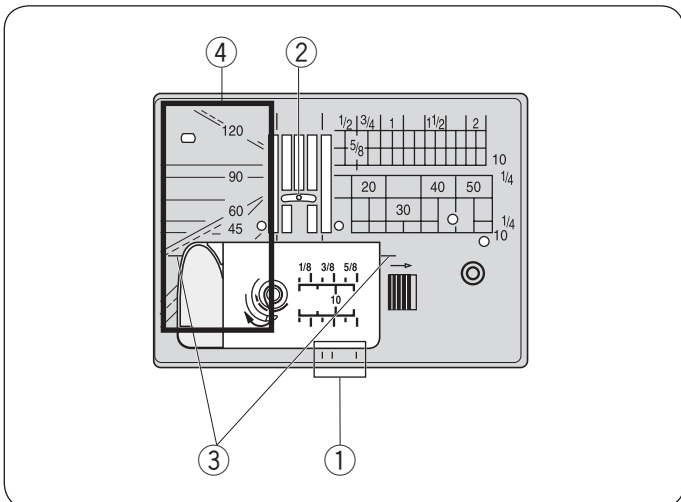

Needle Plate Guides

The seam guides are marked on the needle plate, free arm and hook cover.

The seam guides for 1/4", 3/8" and 5/8" are also marked on the front of the needle plate.

- ① Seam guides on the front of the needle plate

The numbers on the needle plate indicate the distance from the center needle position in millimeters and inches.

- ② Center needle position

The cornering guides are very useful when turning a square corner.

- ③ Cornering guide

The angle scales on the needle plate are useful for patchwork piecing (refer to page 75).

- ④ Angle scales

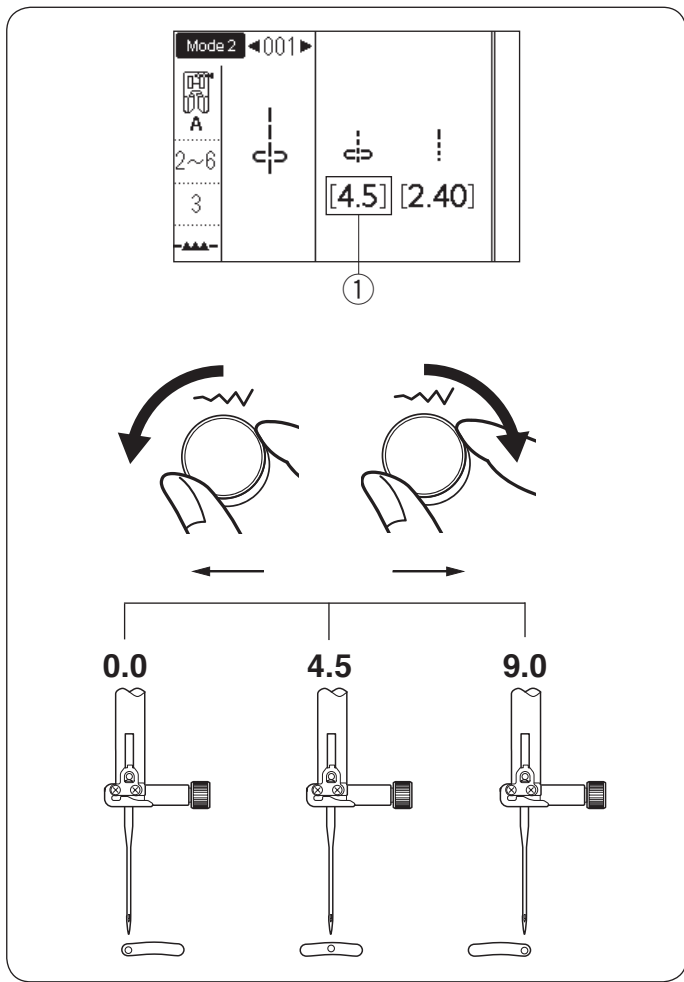

Adjusting the Needle Drop Position

The needle drop position of the straight stitches can be altered by turning the stitch width adjusting dial.

NOTE:

The value in brackets ① indicates the preset setting.

The needle drop position can be adjusted for the following straight stitch patterns.

Mode 1			
①	②	③	④

Mode 2											
001	002	003	004	005	012	082	083	084	085	086	087
135	136	137	138	140	142						

Turn the stitch width adjusting dial clockwise to move the needle drop position to the right.

Turn the stitch width adjusting dial counterclockwise to move the needle drop position to the left.

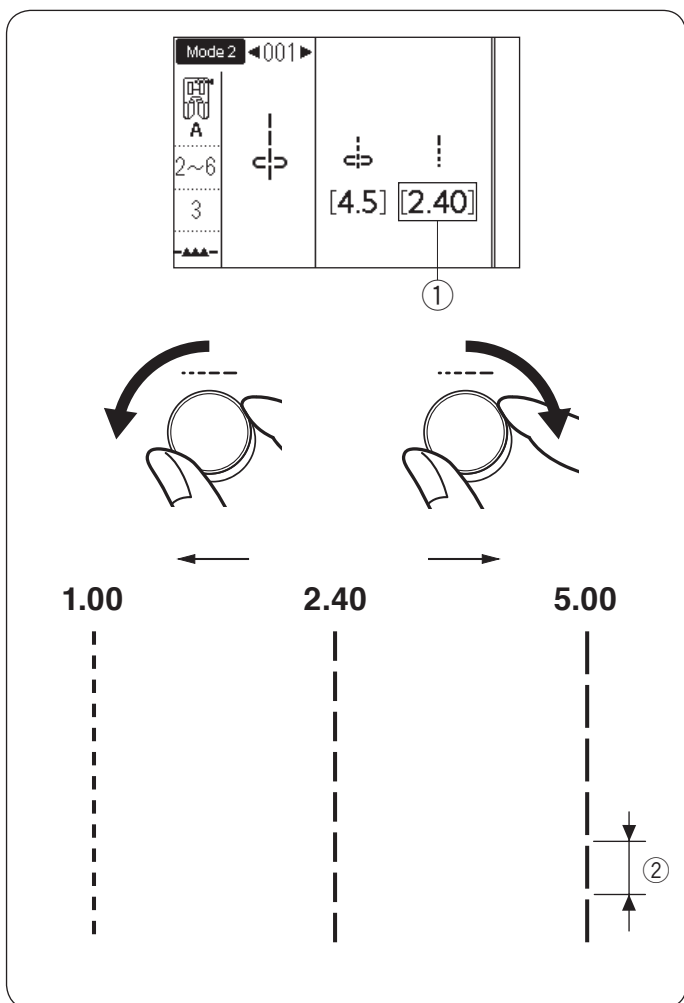

Adjusting the Stitch Length

The stitch length can be altered by turning the stitch length adjusting dial.

NOTE:

The value in the brackets ① indicates the preset setting.

Turn the stitch length adjusting dial clockwise to increase the stitch length.

Turn the stitch length adjusting dial counterclockwise to decrease the stitch length.

② Stitch length

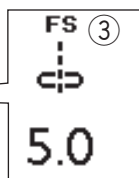
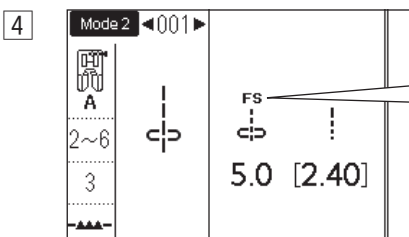
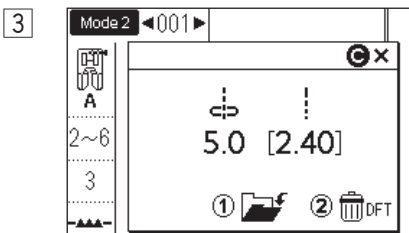
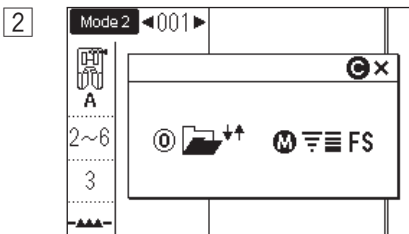
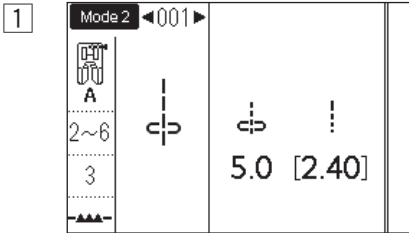
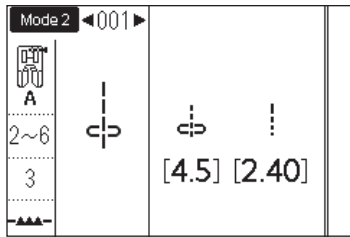

Favorite Stitch Adjustment

The preset value of the stitch length and width are optimized for the selected pattern. However, you can save customized stitch settings (stitch length, stitch width, elongation rate, depending on the selected stitch patterns) as Favorite Stitch Adjustment. When the favorite stitch adjustment option is turned ON (refer to page 35), the last-saved customized stitch settings are automatically assigned when the stitch pattern is selected.

NOTE:

Favorite stitch option cannot be used in monogram mode (mode 3).

Example: To change the preset value of the needle drop position from “4.5” to “5.0”.

Turn the Favorite Stitch Adjustment option ON (refer to page 35).

- 1 Select the stitch pattern 001 in mode 2.
Turn the stitch width adjusting dial to change the needle drop position at “5.0”.
- 2 Press the folder/FS key. The selection window appears.
Press the memory key.
 - 1 Folder/FS key
 - 2 Memory key
- 3 The LCD screen will show custom setting window.
Press the “1” key to register the favorite stitch settings.
- 4 The LCD screen will return to the previous window and the symbol “FS” ③ will appear on the screen to indicate that the preset value has been changed.

Restoring the default settings

Select the stitch pattern for which you have changed settings.

Press the folder/FS key. The LCD screen will show the custom setting window with the customized settings.

Press the memory key.

Press the “2” key. The confirmation screen appears.

Press the memory key.

The LCD screen will return to the previous window and the symbol “FS” will disappear.

The preset values will return to the default setting.

NOTE:

Refer to page 35 for restoring all the FS settings.

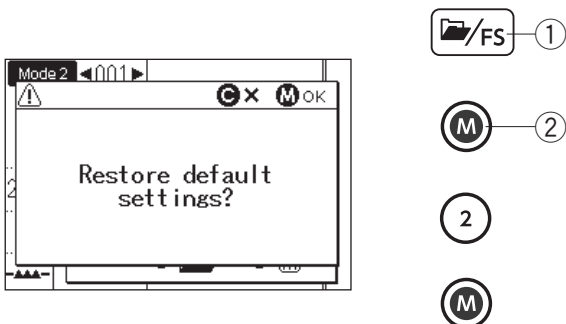

Sewing with the Dual Feed Device

The dual feed device is extremely effective when sewing hard to feed materials such as PVC coated fabric or leather.

It also eliminates layer slippage.

See page 16 for how to attach the dual feed foot and to engage the dual feed device.

The following stitch patterns can be sewn with the dual feed device.

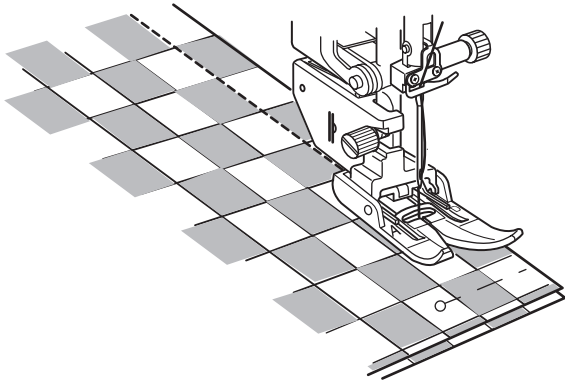

Mode 1			
①	②	③	④

Mode 2													
001	002	003	004	005	012	082	083	084	085	086	087	088	089
135	136	137	138	140	142								

Place the fabric under the foot and lower the needle at the point where you want to start.
Start sewing at medium speed.

When seaming plaid fabrics, match the plaids of the upper and lower layers and pin them together.
Remove the pins as you sew.

Dual feed balancing dial

The dual feed balancing dial should be set at "0", however you may need to adjust the dual feed balance depending on the type of fabric.

Check the feed balance by test sewing on a scrap piece of the fabric you intend to use.

(A): If the lower layer puckers, turn the dual feed balancing dial toward "+".

(B): If the upper layer puckers, turn the dual feed balancing dial toward "-".

- ① Upper layer
- ② Lower layer
- ③ Dual feed balancing dial

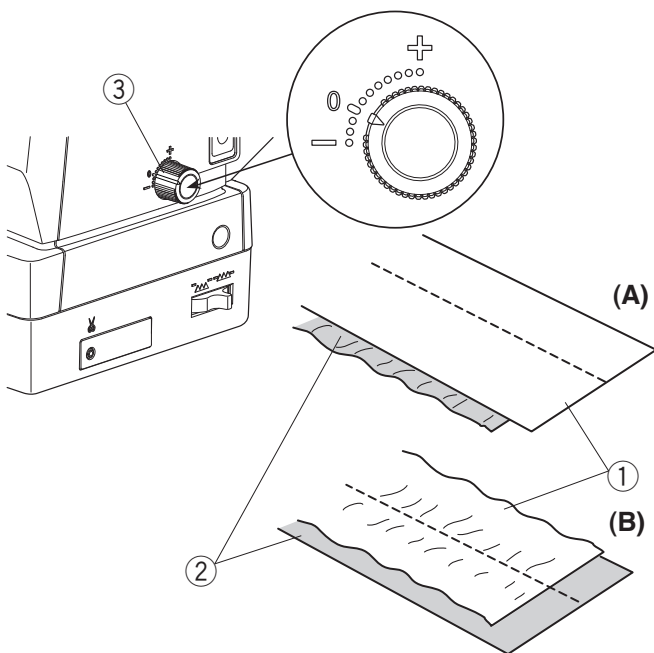

Sewing with the Professional grade foot HP

Use the professional grade foot for the straight stitch with a professional result.

The following stitch patterns can be sewn with the professional grade foot.

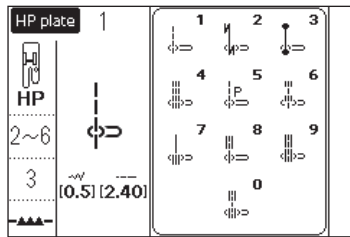
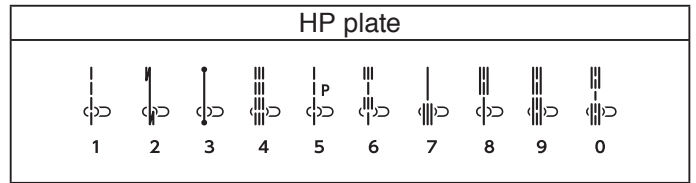
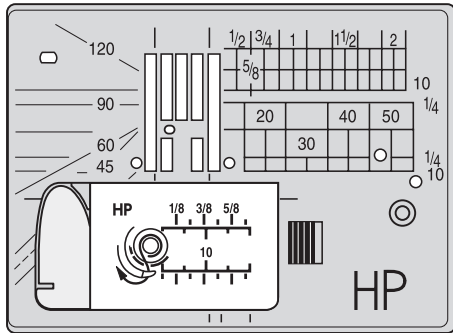

See page 16 for how to attach the professional grade foot.

Replace the needle plate with the professional grade needle plate when using professional grade foot.

Attach the professional grade foot HP.

See page 26 for how to attach the professional grade needle plate.

Select the desired pattern from the selection window.

Place the fabric under the foot and lower the needle at the point where you want to start and sew.

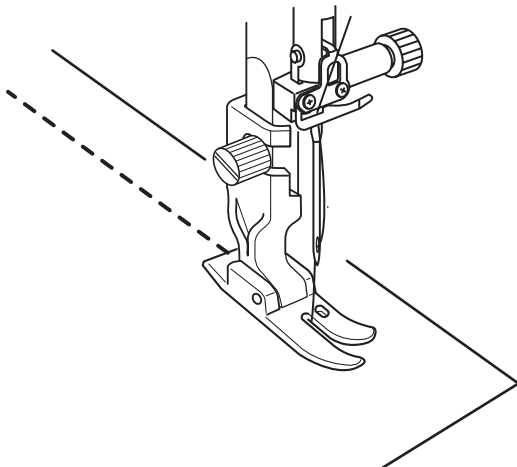

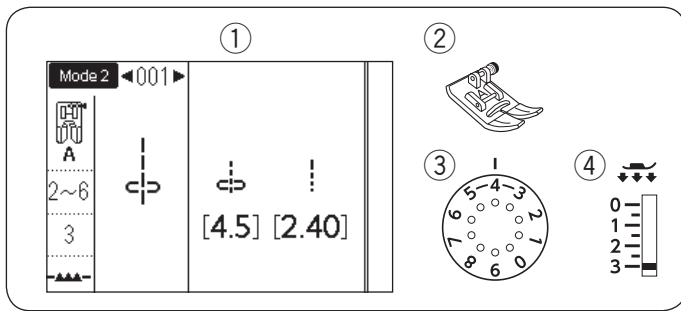

Variety of Straight Stitches

Straight Stitch in Center Needle Position

- ① Pattern: MODE 1: 1 or MODE 2: 001
- ② Presser foot: Zigzag foot A
- ③ Thread tension: 2-6
- ④ Foot pressure: 3

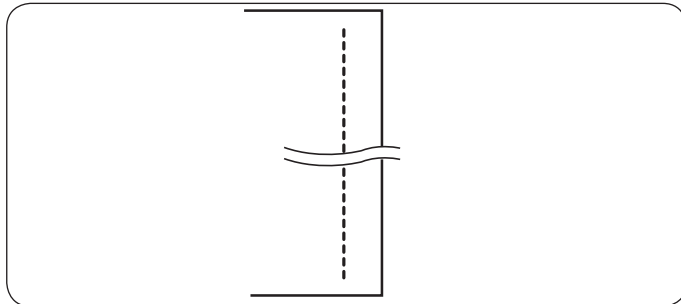

Use this stitch for seaming, rolled hemming etc.

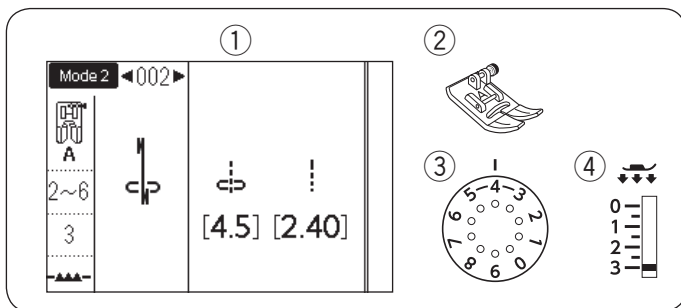

Lock-a-matic Stitch

- ① Pattern: MODE 1: 2 or MODE 2: 002
- ② Presser foot: Zigzag foot A
- ③ Thread tension: 2-6
- ④ Foot pressure: 3

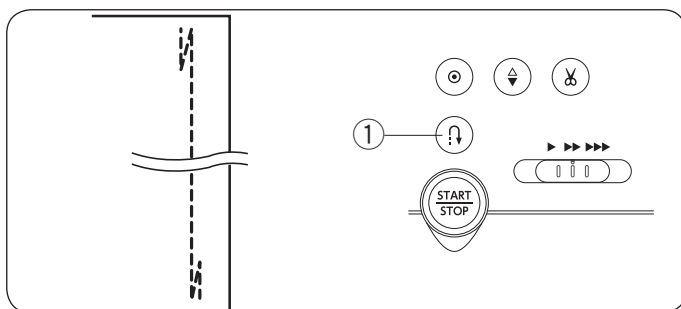

Use this stitch to secure the beginning and the end of a seam with backstitching.

When you reach the end of the seam, press the reverse key ① once.

The machine will sew four reverse stitches, four forward stitches, and then stop sewing automatically.

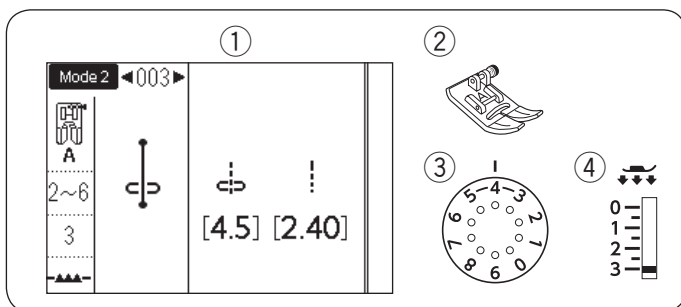

Locking Stitch

- ① Pattern: MODE 1: 3 or MODE 2: 003
- ② Presser foot: Zigzag foot A
- ③ Thread tension: 2-6
- ④ Foot pressure: 3

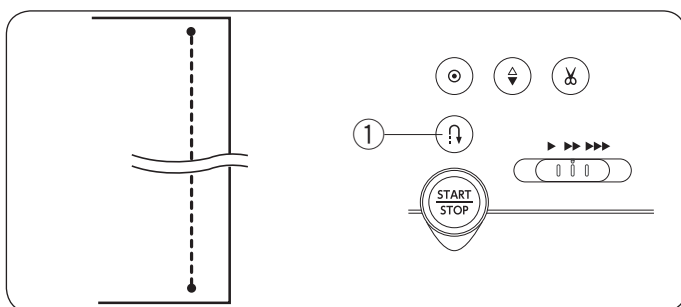

This unique stitch is used where an invisible locking stitch is needed.

The machine will sew several locking stitches at the beginning and continue sewing forward.

When you press the reverse key ① at the end of the seam, the machine will sew several locking stitches in place, then stop sewing automatically.

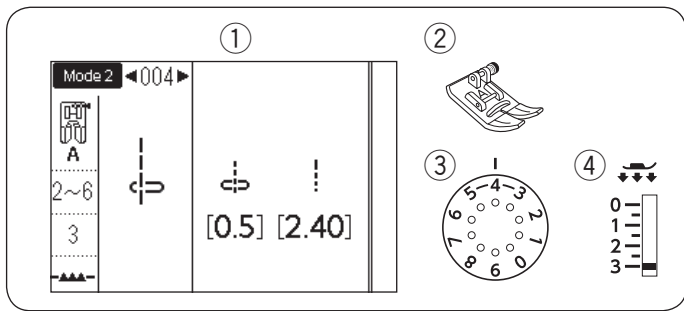

Straight Stitch in Left Needle Position

- ① Pattern: MODE 2: 004
- ② Presser foot: Zigzag foot A
- ③ Thread tension: 2-6
- ④ Foot pressure: 3

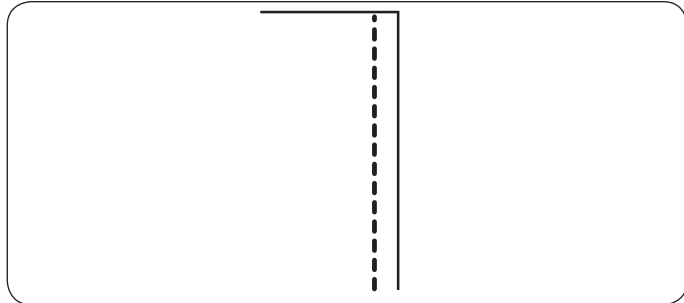

Use this stitch to seam fabrics close to the edge.

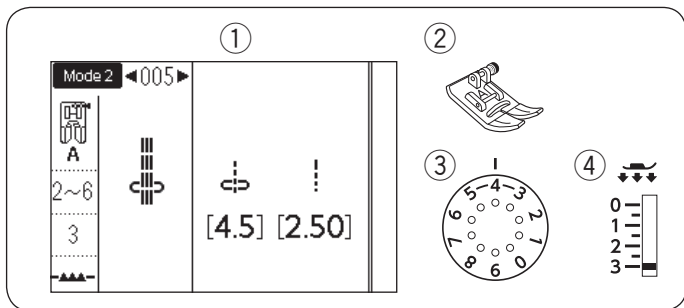

Triple Stretch Stitch

- ① Pattern: MODE 2: 005
- ② Presser foot: Zigzag foot A
- ③ Thread tension: 2-6
- ④ Foot pressure: 3

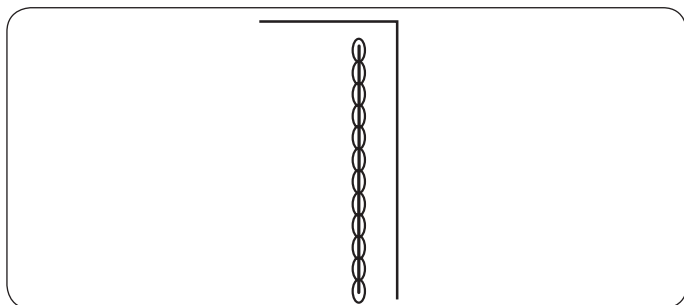

This strong, durable stitch is recommended for areas where both elasticity and strength are needed to ensure comfort and durability.

Use it to reinforce areas such as crotch and armhole seams.

Also use it when constructing items such as backpacks for extra strength.

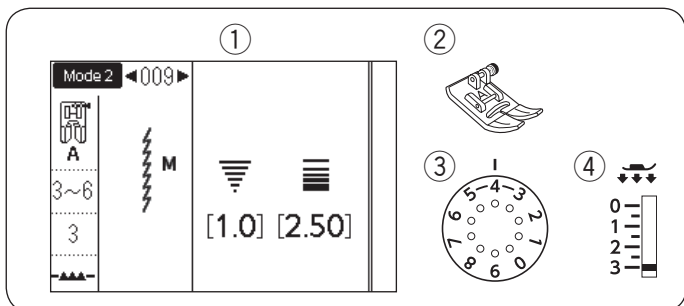

Stretch Stitches

- ① Pattern: MODE 2: 009 or 010
- ② Presser foot: Zigzag foot A
- ③ Thread tension: 3-6
- ④ Foot pressure: 3

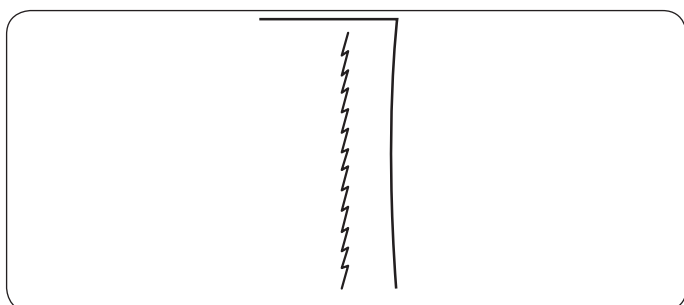

These are narrow stretch stitches designed to eliminate puckering on knit fabrics and bias seams, while permitting the seam to be pressed completely open flat.

Stitch pattern 010 is a stretch stitch in the left needle position.

Use this stitch when seaming fine fabrics or stretch fabrics.

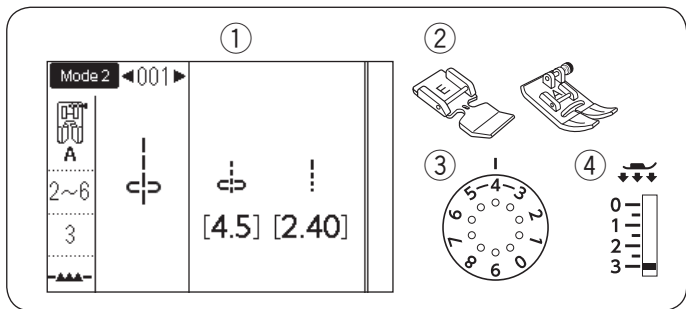

Zipper Sewing

- ① Pattern: MODE 1: 1 or MODE 2: 001
- ② Presser foot: Zipper foot E
Zigzag foot A
- ③ Thread tension: 2-6
- ④ Foot pressure: 3

NOTE:

The needle drop position should be adjusted when sewing with the zipper foot E.

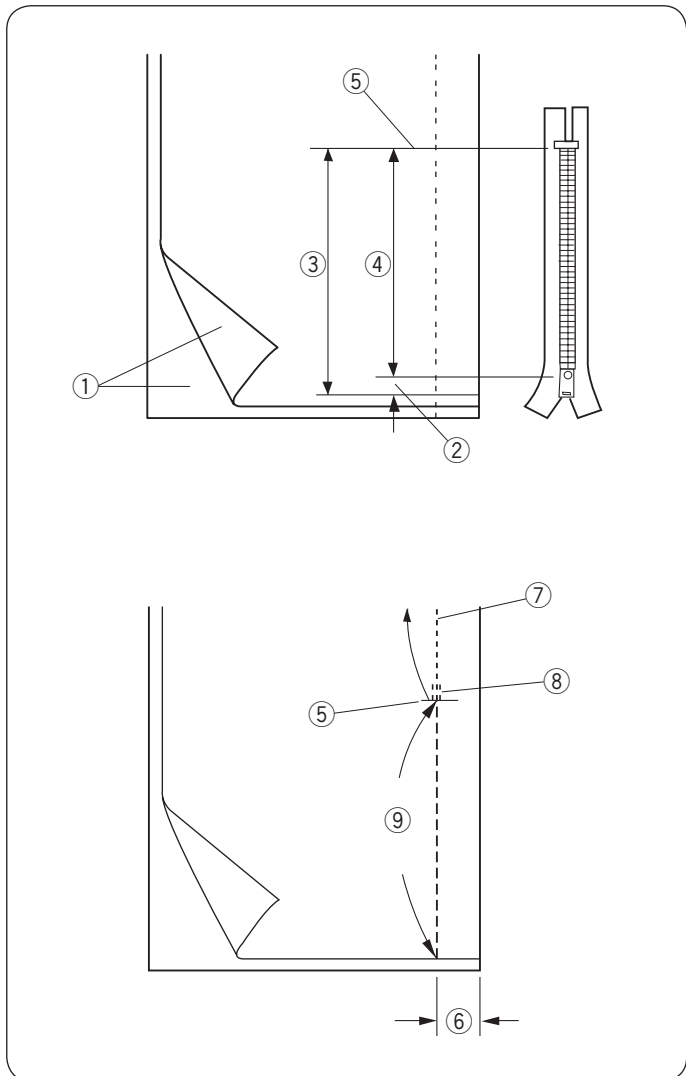

Fabric preparation

Add 1 cm (3/8") to the zipper size. This is the overall opening size.

- ① Right sides of the fabric
- ② 1 cm (3/8")
- ③ Opening size
- ④ Zipper size
- ⑤ End of the zipper opening

Place the right sides of the fabric together and sew to the end of the opening with a 2 cm (5/8") seam allowance.

Reverse stitch to lock the seams.

Manually increase the stitch length to 5.0 and baste the zipper opening with the thread tension loosened to 1-3.

- ⑤ End of the zipper opening
- ⑥ 2 cm (5/8") seam allowance
- ⑦ Seam stitches
- ⑧ Reverse stitches
- ⑨ Basting

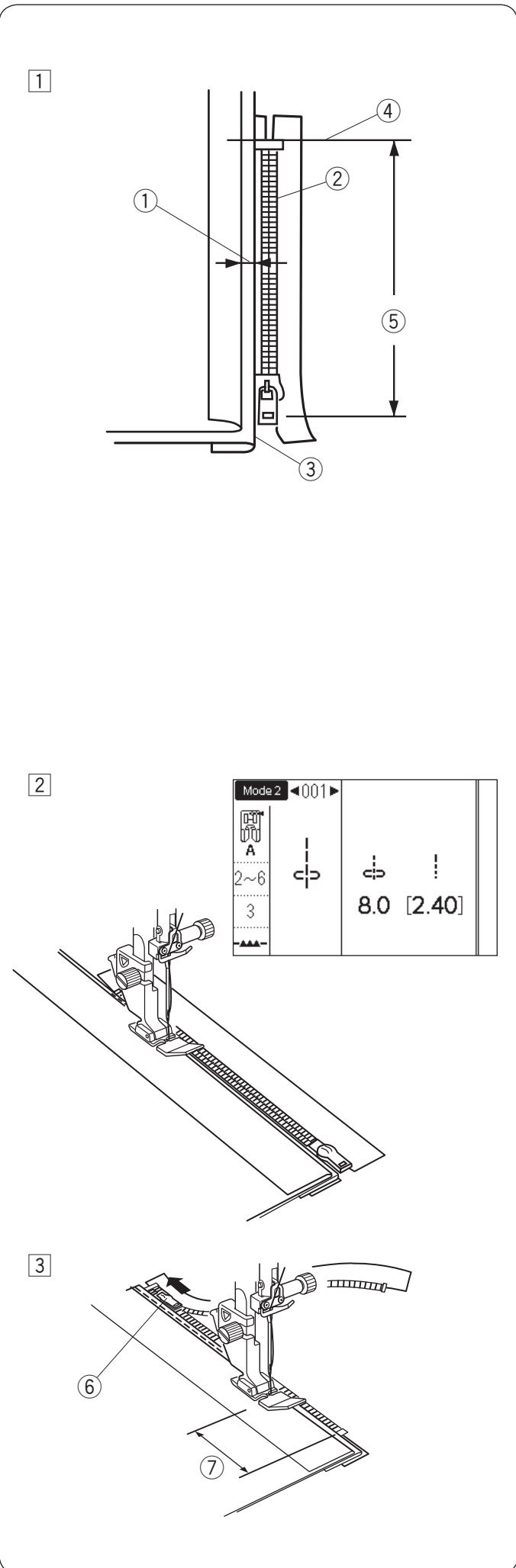

Sewing

- 1 Fold back the left seam allowance. Turn the right seam allowance under to form a 0.2 to 0.3 cm (1/8") margin. Place the zipper teeth next to the fold and pin in place.

Set the stitch length and thread tension back to the original setting.

- ① 0.2 to 0.3 cm (1/8") margin
- ② Zipper teeth
- ③ Fold
- ④ End of the zipper opening
- ⑤ Opening size

- 2 Attach the zipper foot. Adjust the needle drop position to 7.5–8.5. Lower the foot onto the topside at the end of the zipper opening so that the needle pierces the fabric next to the fold and the zipper tape. Sew along the zipper guiding the zipper teeth along the side edge of the foot.



CAUTION:

Be sure that the needle do not strike the presser foot when the zipper foot or zipper teeth is attached and needle drop position is adjusted.

- 3 Sew through all layers next to the fold. Stop 5 cm (2") before zipper foot E reaches the slider on the zipper tape. Lower the needle slightly into the fabric. Raise the foot and open the zipper to clear the slider. Lower the foot and stitch the remainder of the seam.

- ⑥ Slider
- ⑦ 5 cm (2")

4

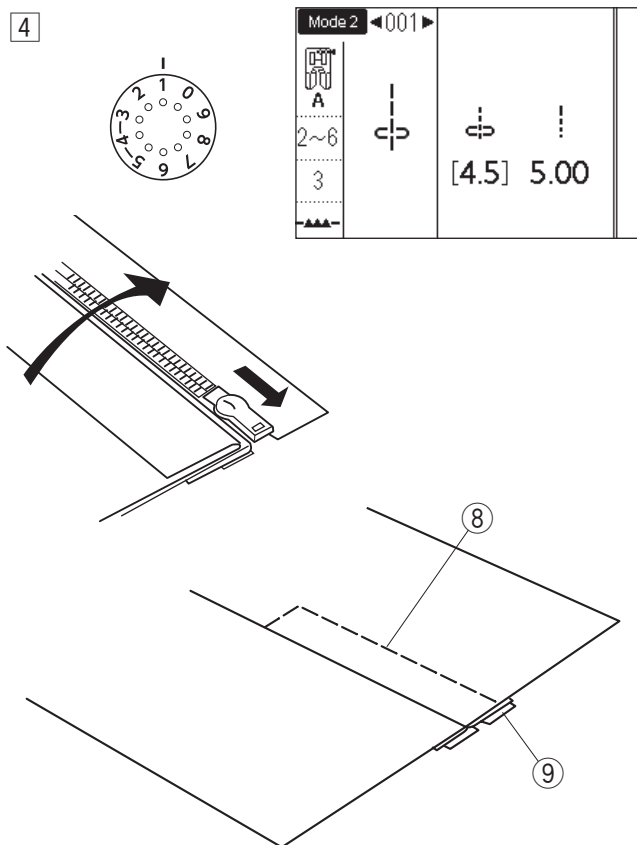

- 4 Close the zipper and spread the fabric open flat with the right side facing up. Attach the Zigzag foot A. Adjust the stitch length to 5.00, needle drop position to 4.5 (default value) and thread tension dial to 1. Baste the opened fabric and zipper tape together.
- ⑧ Basting
 - ⑨ Zipper tape

5 6

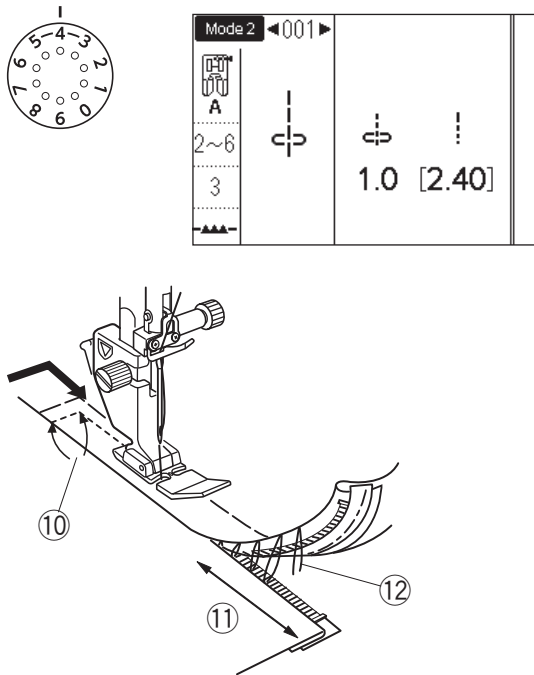

- 5 Attach the zipper foot E. Adjust the stitch length to default value, needle drop position to 0.5–1.5, thread tension dial to “4”. Backstitch across the end of the opening 0.7-1 cm (3/8”) and turn the fabric 90 degrees.
- ⑩ 0.7-1 cm (3/8”)

**CAUTION:**

Be sure that the needle do not strike the presser foot when the zipper foot or zipper teeth is attached and needle drop position is adjusted.

- 6 Stitch through the garment and zipper tape, guiding the zipper teeth along the side edge of the foot. Stop about 5 cm (2”) from the top of the zipper. Unfasten the basting stitches.
- ⑪ 5 cm (2”)
 - ⑫ Basting stitches
- 7 Lower the needle into the fabric, raise the foot, and open the zipper. Lower the foot and stitch the remainder of the seam, making sure the fold is even. Remove the basting threads after seaming.

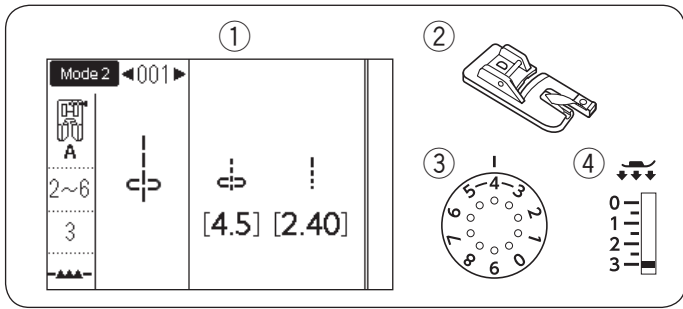

Rolled Hem

- ① Pattern: MODE1: 1 or MODE 2: 001
- ② Presser foot: Rolled hem foot D
- ③ Thread tension: 2-6
- ④ Foot pressure: 3

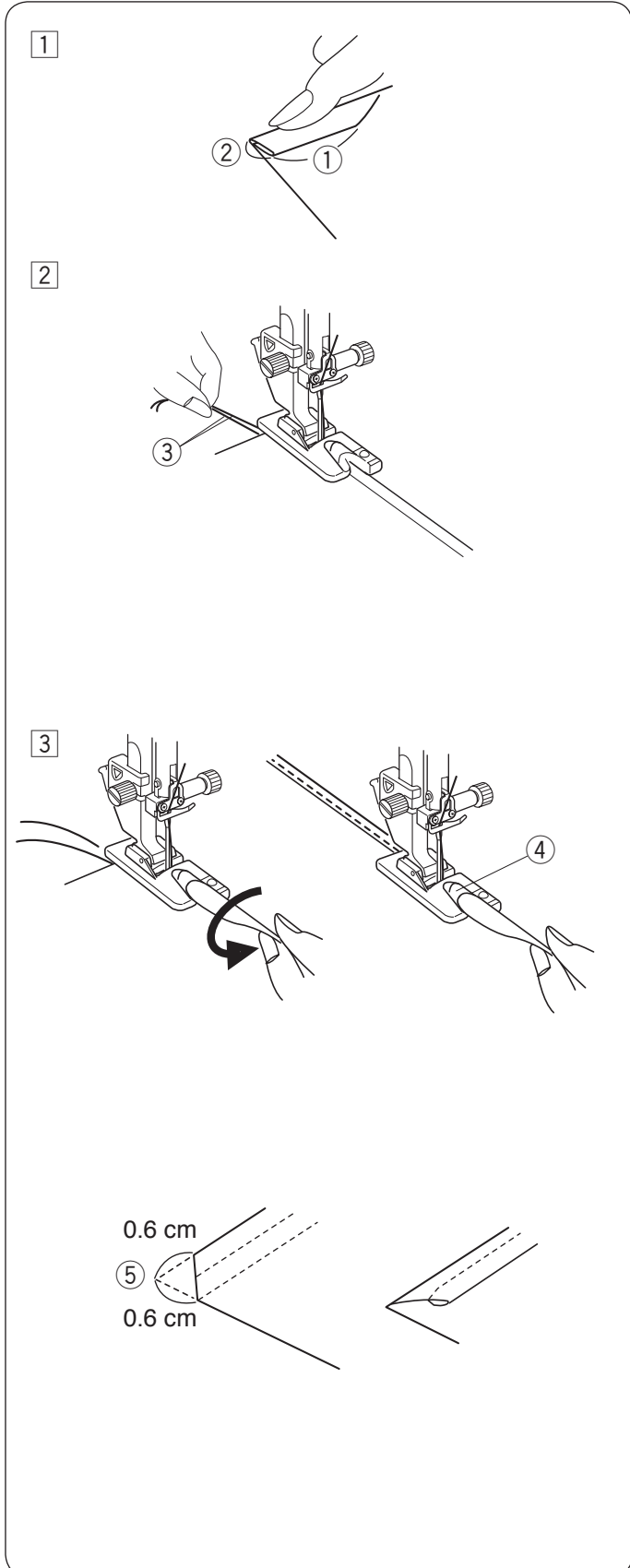

Sewing

- ① Fold the edge of the fabric twice, 6 cm (2 - 3/8") in length and 0.3 cm (1/8") in width.
 - ① 6 cm (2 - 3/8")
 - ② 0.3 cm (1/8")
- ② Place the fabric aligning the edge of the hem with the guide on the foot. Lower the foot and sew 1-2 cm (1/2"-1") while pulling both thread to the back.
 - ③ Threads
- ③ Stop the machine and lower the needle into the fabric. Raise the foot and insert the folded portion of the fabric into the curl of the foot. Lower the foot, and then sew by lifting up the edge of the fabric to keep it feeding smoothly and evenly.
 - ④ Curl of the foot

NOTE:

- Trim the corner 0.6 cm (1/4") to reduce bulk.
 - ⑤ 0.6 cm (1/4")

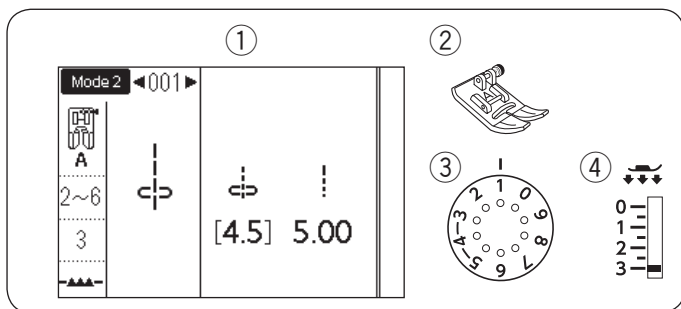

Gathering

- ① Pattern: MODE 1: 1 or MODE 2: 001
- ② Presser foot: Zigzag foot A
- ③ Thread tension: 1
- ④ Foot pressure: 3

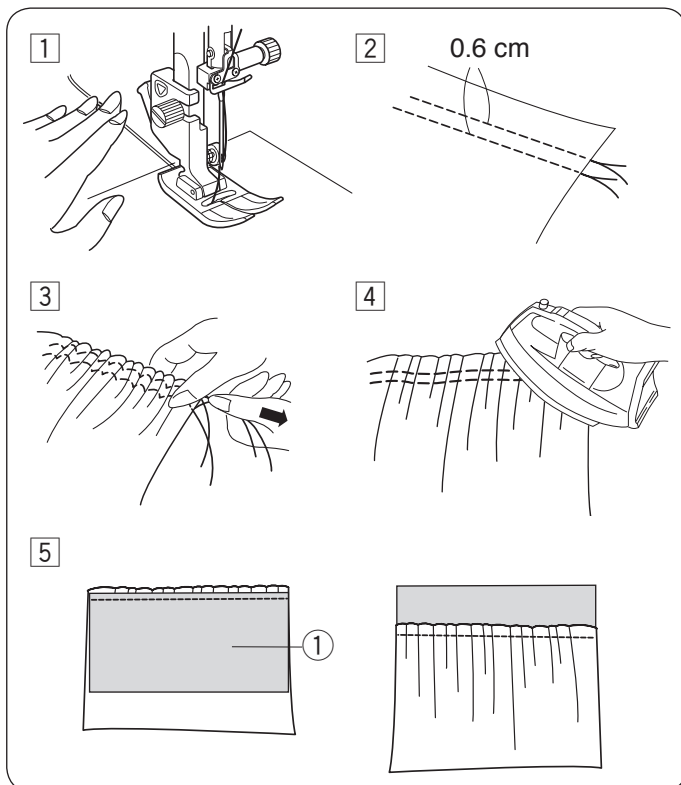

- ① Loosen the thread tension to “1” and increase the stitch length to 5.00.
Pull both threads 10 cm (4”) under and behind the presser foot (refer to page 25).
- ② Sew two rows of straight stitches 0.6 cm (1/4”) apart.
Knot the threads at the beginning.
- ③ Pull the bobbin threads at the end to gather the fabric.
- ④ Knot the threads at the end and distribute the gathers evenly.
- ⑤ Prepare the fabric to attach the gathering.
Tighten the thread tension to “4” and decrease the stitch length to “2.40” (default settings).
Place the wrong side of the fabric ① under the gathering.
Sew the straight stitch between the two gathering rows.
Remove the two rows of straight stitches.

NOTE:

You may sew the straight stitch under the two gathering rows to cover the remains of gathering rows.

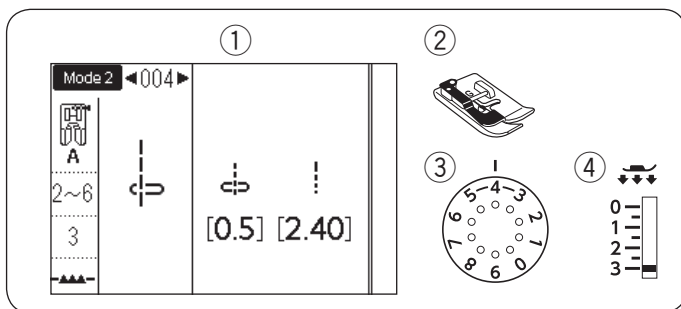

Pintucking

- ① Pattern: MODE 2: 004
- ② Presser foot: Blind hem foot G
- ③ Thread tension: 2-6
- ④ Foot pressure: 3

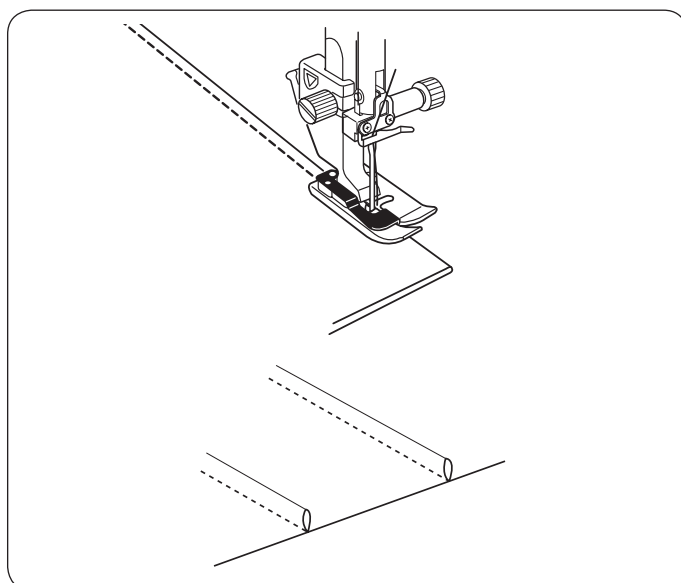

Fold the fabric with the wrong sides together.
Place the folded fabric under the blind hem foot.
Align the edge of the fold with the guide on the foot, and lower the foot.
You may adjust the needle drop position to 0.5-1.5 if necessary.
Sew while guiding the edge of the fold along the guide.

Open the fabric and press the tuck to one side.

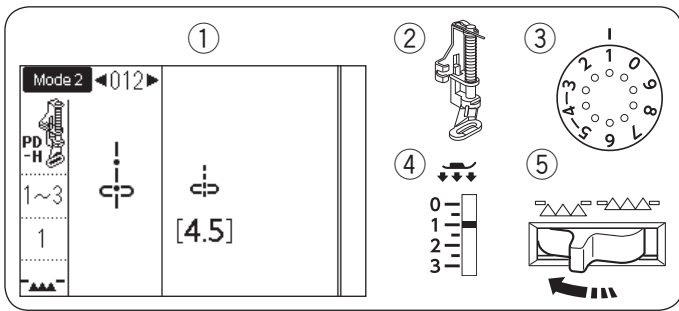

Basting

- | | |
|-------------------|-------------------|
| ① Pattern: | MODE 2: 012 |
| ② Presser foot: | Darning foot PD-H |
| ③ Thread tension: | 1-3 |
| ④ Foot pressure: | 1 |
| ⑤ Feed dog: | Lowered |

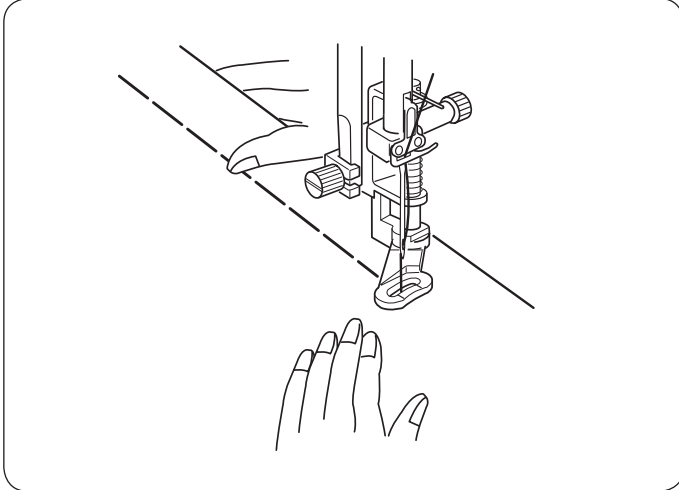

NOTE:

Refer to page 16 for how to attach the darning foot PD-H.

To sew

Hold the fabric taut and depress the foot control. The machine will make one stitch and stop automatically. Slide the fabric to the rear for the next stitch.

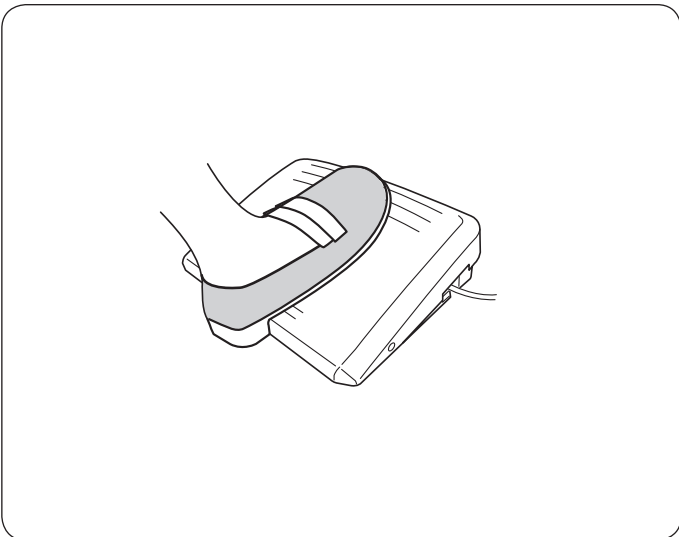

NOTE:

Use foot control for your convenience when basting.

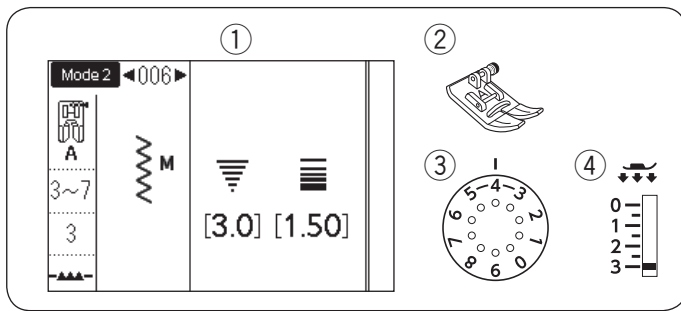

Zigzag Stitches

- ① Pattern: MODE 1: 5
MODE 2: 006, 007 or 008
- ② Presser foot: Zigzag foot A
- ③ Thread tension: 3-7
- ④ Foot pressure: 3

Zigzag stitch is used for various sewing needs including overcasting. It can be used on most woven fabrics. A dense zigzag stitch can also be used for applique.

Adjusting the stitch length

The stitch length of the zigzag stitches can be altered by turning the stitch length adjusting dial.

NOTE:

The value in brackets ① indicates the preset setting.

Turn the stitch length adjusting dial clockwise to increase the stitch length.

Turn the stitch length adjusting dial counterclockwise to decrease the stitch length.

- ② Stitch length

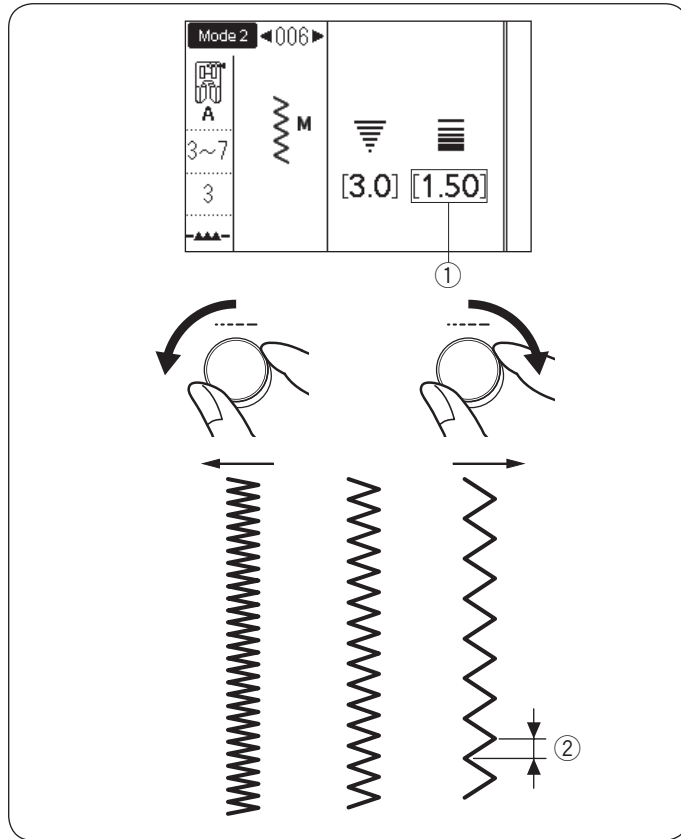

Adjusting the stitch width

The stitch width of the zigzag stitches can be altered by turning the stitch width adjusting dial.

NOTE:

The value in brackets ① indicates the preset setting.

Turn the stitch width adjusting dial clockwise to increase the stitch width.

Turn the stitch width adjusting dial counterclockwise to decrease the stitch width.

- ② Stitch width

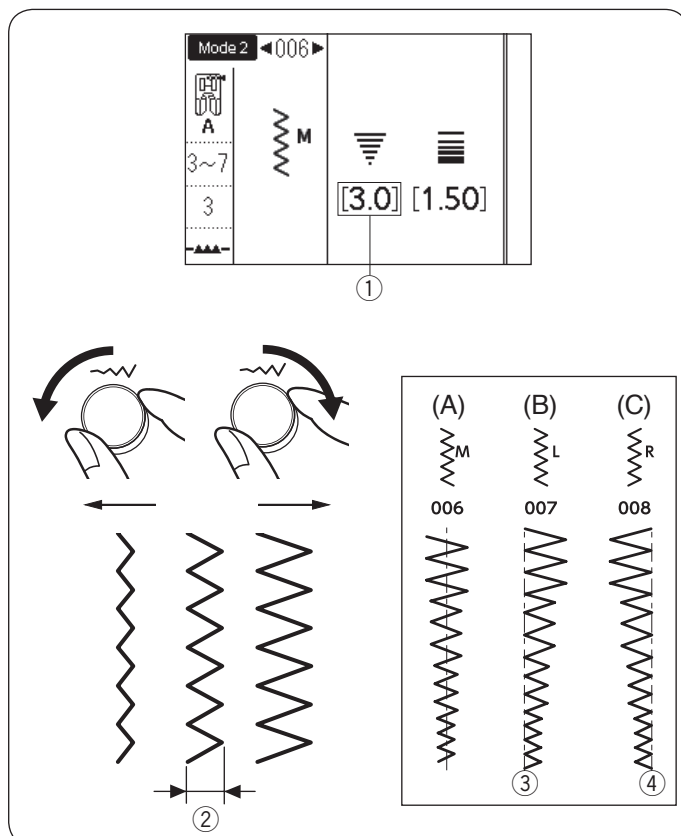

(A): The pattern number 006 in mode 2 has a fixed center needle drop position. The stitch width changes symmetrically.

(B): The pattern number 007 in mode 2 has a fixed left needle drop position. When you change the stitch width, the right needle drop position will change.

(C): The pattern number 008 in mode 2 has a fixed right needle drop position. When you change the stitch width, the left needle drop position will change.

- ③ Fixed left needle position
- ④ Fixed right needle position

Variety of Overcasting Stitches

Multiple Zigzag Stitch

- ① Pattern: MODE 1: 6 or MODE 2: 011
- ② Presser foot: Zigzag foot A
- ③ Thread tension: 3-6
- ④ Foot pressure: 3

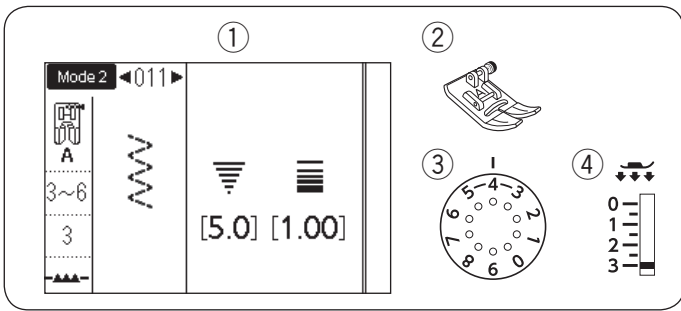

This stitch is used to finish a raw edge of synthetics and other stretch fabrics that tend to pucker.

Sew along the fabric edge leaving an adequate seam allowance. After sewing, trim off the seam allowance closer to the stitches.

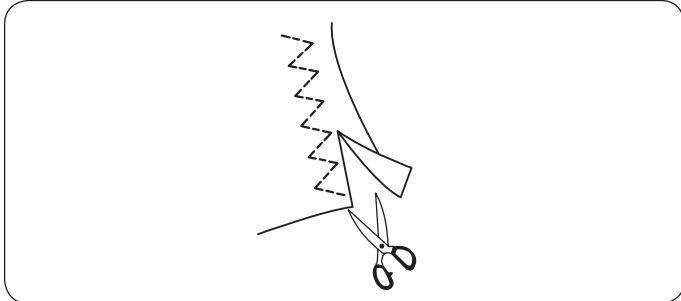

Overcasting Stitch

- ① Pattern: MODE 2: 013
- ② Presser foot: Overcasting foot M
- ③ Thread tension: 3-7
- ④ Foot pressure: 3

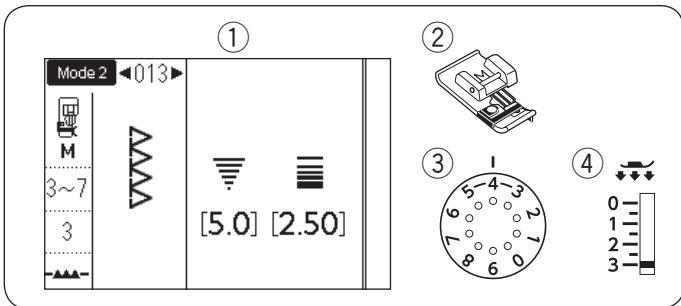

This stitch can be used to simultaneously seam and overcast edges of fabrics.

Use this stitch when you do not need to open seams flat. Place the fabric edge next to the guide of the foot and sew.

- ① Guide
- ② Edge of fabric

NOTE:

The stitch width cannot be changed.

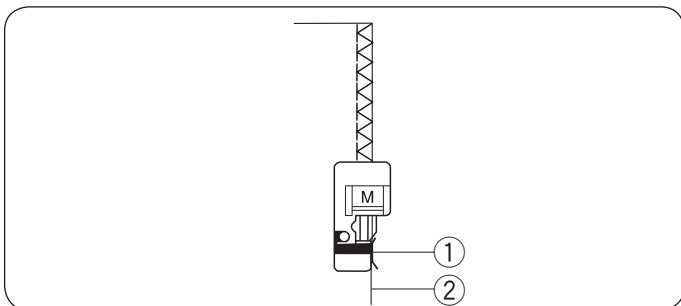

Knit Stitch

- ① Pattern: MODE 2: 014
- ② Presser foot: Overcasting foot M
- ③ Thread tension: 3-6
- ④ Foot pressure: 3

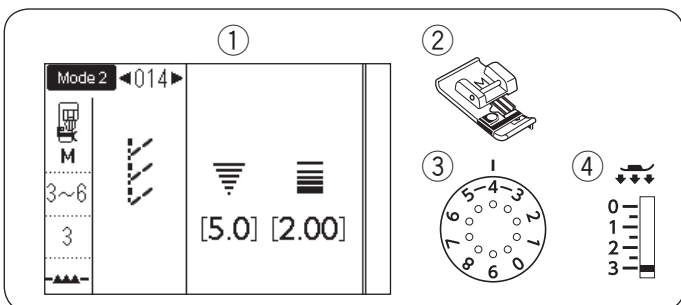

This stitch is recommended for sewing such fabrics as synthetic knits and stretch velour as it provides the greatest amount of elasticity and strength.

Place the fabric edge next to the guide of the foot and sew.

For better results, use the zigzag foot A and sew leaving an adequate seam allowance.

After sewing, trim the seam allowance close to the stitches.

- ① Guide
- ② Edge of fabric

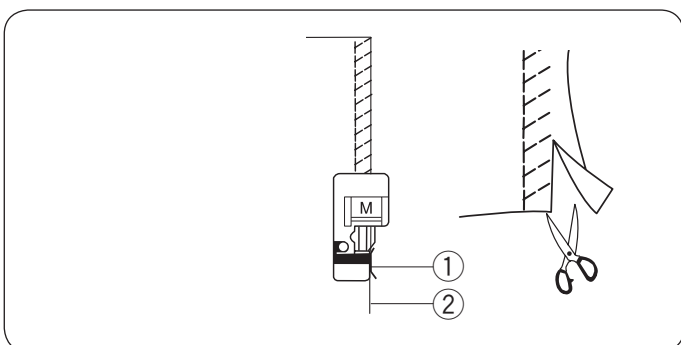

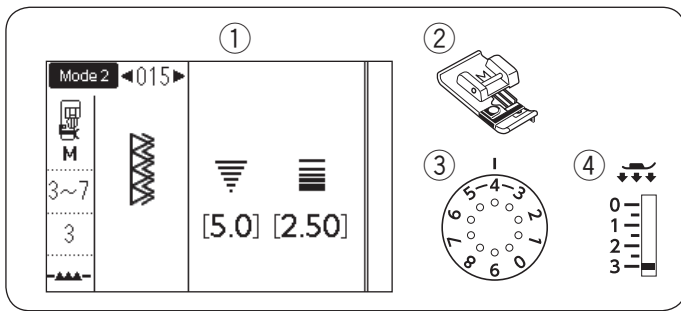

Double Overcasting Stitch

- ① Pattern: MODE 2: 015
- ② Presser foot: Overcasting foot M
- ③ Thread tension: 3-7
- ④ Foot pressure: 3

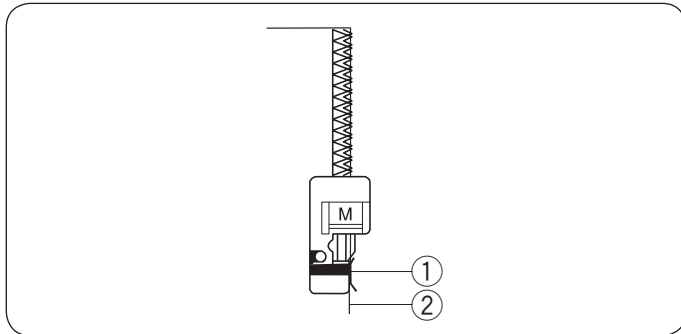

This is an excellent stitch for fabrics that tend to fray extensively such as linens and gabardines. Two rows of zigzag stitches are simultaneously sewn over the edge to insure that fabric will not ravel. Place the fabric edge next to the guide of the foot and then sew.

- ① Guide
- ② Edge of fabric

NOTE:

The stitch width cannot be changed.

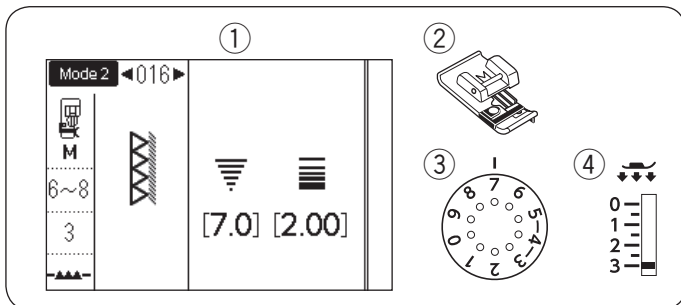

Overlocking Stitch

- ① Pattern: MODE 2: 016
- ② Presser foot: Overcasting foot M
- ③ Thread tension: 6-8
- ④ Foot pressure: 3

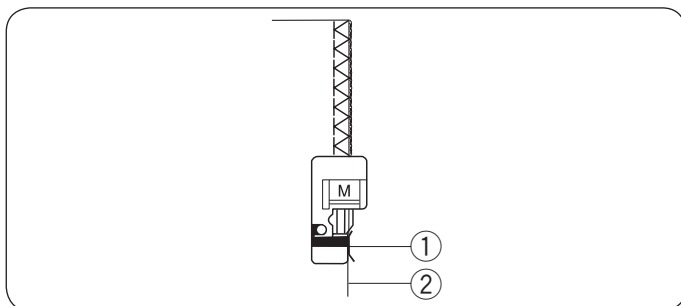

This stitch can be used to simultaneously seam and overcast edges of fabrics. Use this stitch when you do not need to open seams flat. Place the fabric edge next to the guide of the foot and sew.

- ① Guide
- ② Edge of fabric

NOTE:

The stitch width cannot be changed.

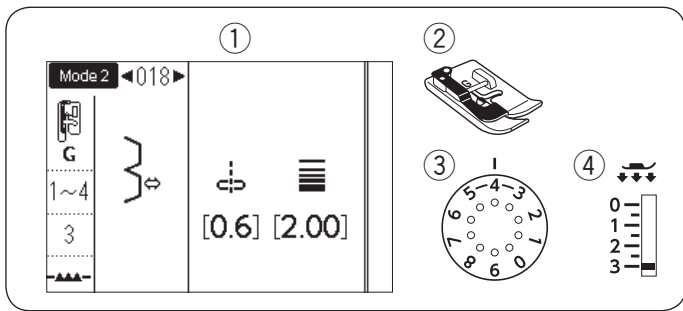

Blind Hemming

- | | |
|-------------------|--|
| ① Pattern: | MODE 2: 018 or 019 |
| ② Presser foot: | Blind hem foot G |
| ③ Thread tension: | 1-4 (pattern 018)
3-6 (pattern 019) |
| ④ Foot pressure: | 3 |

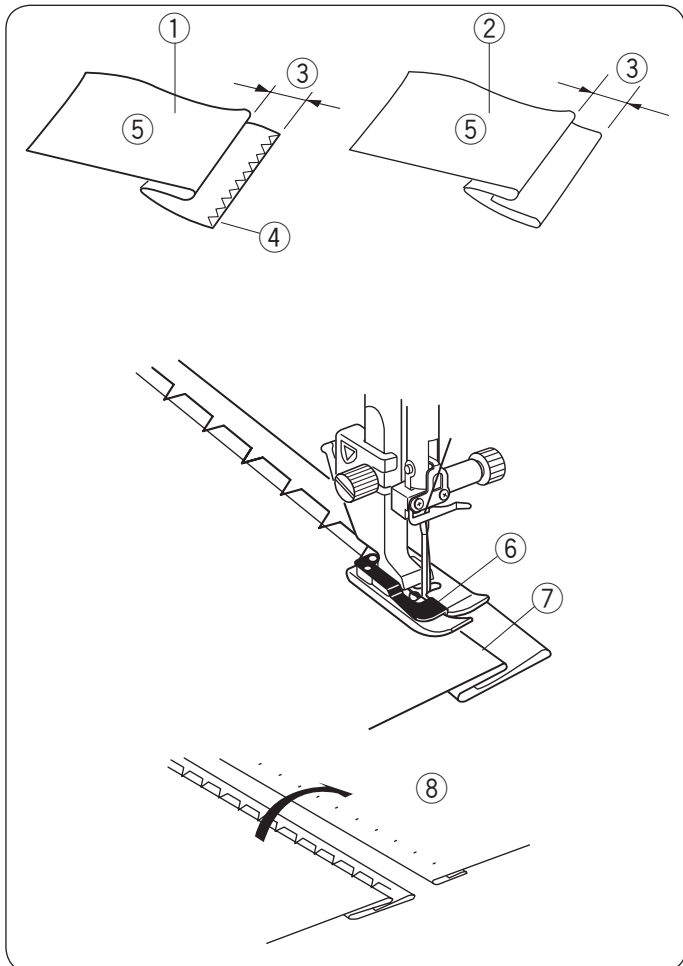

Select pattern 018 in mode 2 for woven fabrics or pattern 19 in mode 2 for elastic fabrics.

Folding the fabric

Fold the fabric to make a hem as shown.

- ① Heavy fabric
- ② Fine to medium fabric
- ③ 0.4 – 0.7 cm (3/16"–1/4")
- ④ Overcasting
- ⑤ Wrong side of fabric

Sewing

Position the fabric so that the fold comes to the left side of the guide on the foot.

Lower the presser foot.

Adjust the position of the needle swing with the stitch width adjusting dial so that the needle just pierces the folded edge of the fabric when the needle comes over to the left side.

Sew guiding the fold along the guide.

- ⑥ Guide on the foot
- ⑦ Fold

Open the fabric with the right side up.

The stitches on the right side of the fabric will be almost invisible.

- ⑧ Right side of fabric

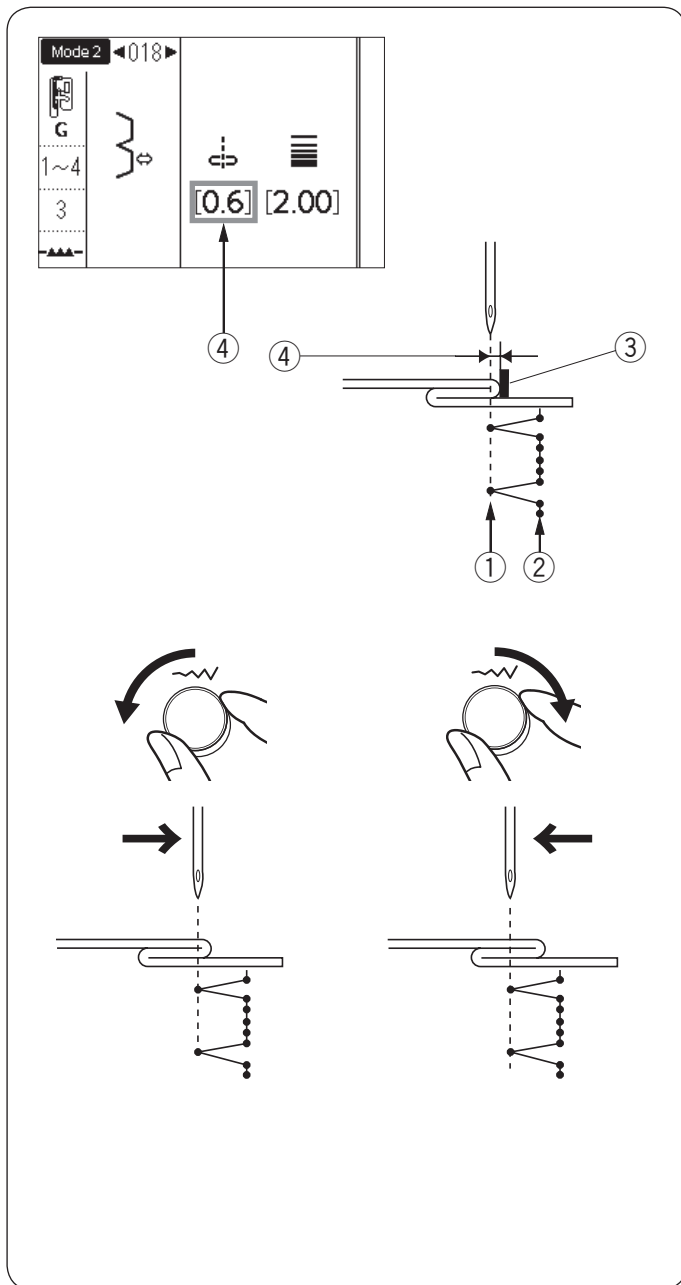

Changing the needle drop position

The LCD screen shows the distance between the left needle position and the guide in millimeters ④.

Turn the stitch width adjusting dial counterclockwise to move the needle drop position to the right.

Turn the stitch width adjusting dial clockwise to move the needle drop position to the left.

- ① Left needle drop position
- ② Right needle drop position
- ③ Guide on foot
- ④ Distance between the left needle position and the guide

NOTE:

The stitch width of patterns 018 and 019 cannot be changed, but the needle drop position will move.

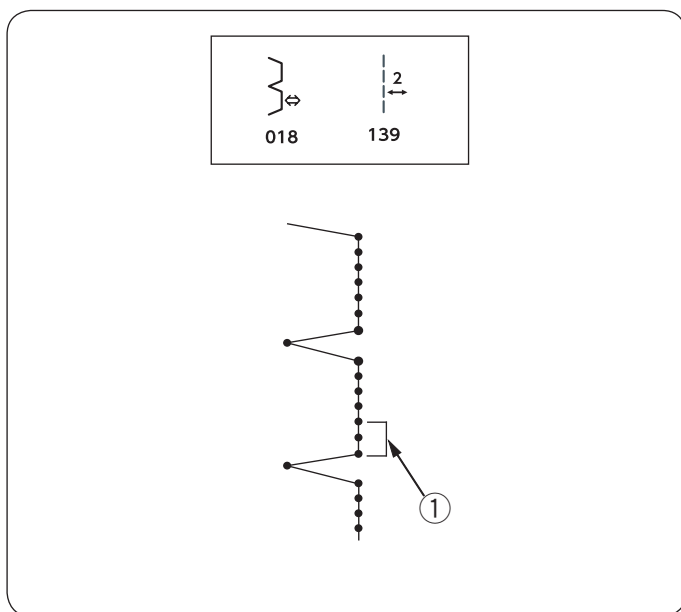

Making the straight stitches in pattern number 018 longer

Program a combination of patterns 018 and pattern 139 in mode 2.

Two straight stitches ① will be added to the blind hem stitch when combining with pattern 139. (Refer to page 89).

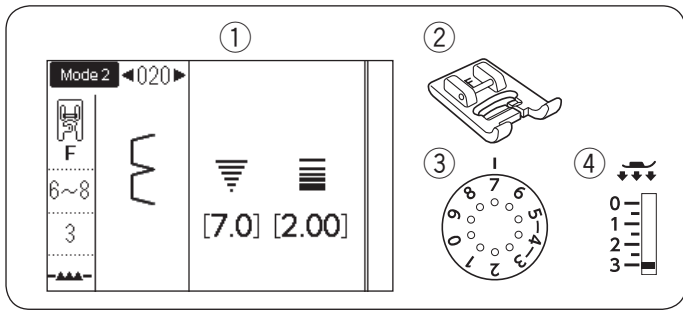

Shell Tuck

- | | |
|-------------------|---------------------|
| ① Pattern: | MODE 2: 020 |
| ② Presser foot: | Satin stitch foot F |
| ③ Thread tension: | 6-8 |
| ④ Foot pressure: | 3 |

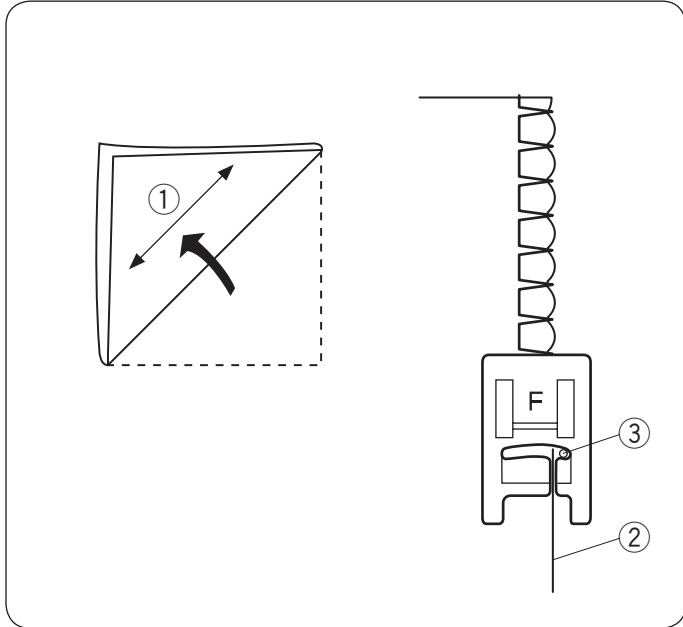

Use a light weight fabric (tricot, for example). Fold the fabric on the bias as shown and stitch on the fold.

Allow the needle to just clear the folded edge to create a shelled edge. You may need to increase the needle thread tension.

- ① Bias
- ② Folded edge
- ③ Right needle drop position

If you sew rows of shell stitches, space the rows at least 1.5 cm (5/8") apart.

You can also sew shell stitches on knits or soft silky woven fabrics in any direction.



023

MEM



024



025



026



027



028



029



030



031

Variety of Buttonholes

023 Sensor (Square) buttonhole

This square buttonhole is widely used on medium to heavy weight fabrics. The buttonhole size is automatically determined by placing a button in the foot.

024 Automatic (Square) buttonhole

This is also a square buttonhole similar to the sensor square buttonhole, but you can manually set the buttonhole size and the machine memorizes it to sew buttonholes of the same size.

025 Round end buttonhole

This buttonhole is used on fine to medium weight fabrics especially for blouses and children's clothes.

026 Fine fabric buttonhole

This buttonhole is rounded at both ends and is used on fine, delicate fabrics such as fine silk.

027 Keyhole buttonhole

The keyhole buttonhole is widely used on medium to heavy weight fabrics. It is also suitable for larger and thicker buttons.

028 Rounded keyhole buttonhole

This buttonhole is used for thicker buttons on medium weight fabrics.

029 Tailored buttonhole

This durable buttonhole is used with thick buttons and heavy fabrics.

030 Stretch buttonhole

This buttonhole is suitable for stretch fabrics. It can also be used as a decorative buttonhole.

031 Knit buttonhole

This buttonhole is suitable for knit fabrics. It can also be used as a decorative buttonhole.

NOTE:

025-031 are sensor buttonholes and the sewing procedure is the same as for 023.

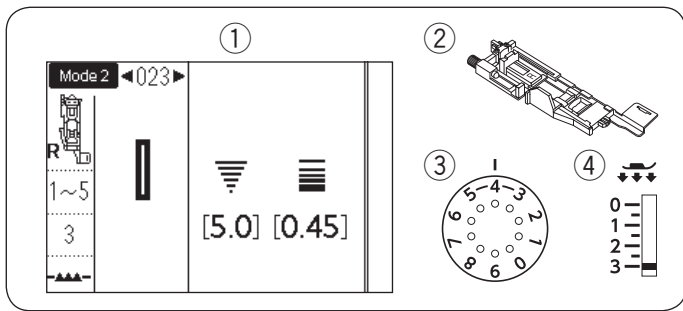

Sensor (Square) Buttonhole

- ① Pattern: MODE 2: 023
- ② Presser foot: Automatic buttonhole foot R
- ③ Thread tension: 1-5
- ④ Foot pressure: 3

The size of a buttonhole is automatically set by placing a button in the rear of automatic buttonhole foot R. The button holder of the foot takes a button size of 1 cm (3/8") to 2.5 cm (1") in diameter. When selecting the buttonholes, the LCD screen advise you to lower the buttonhole lever.

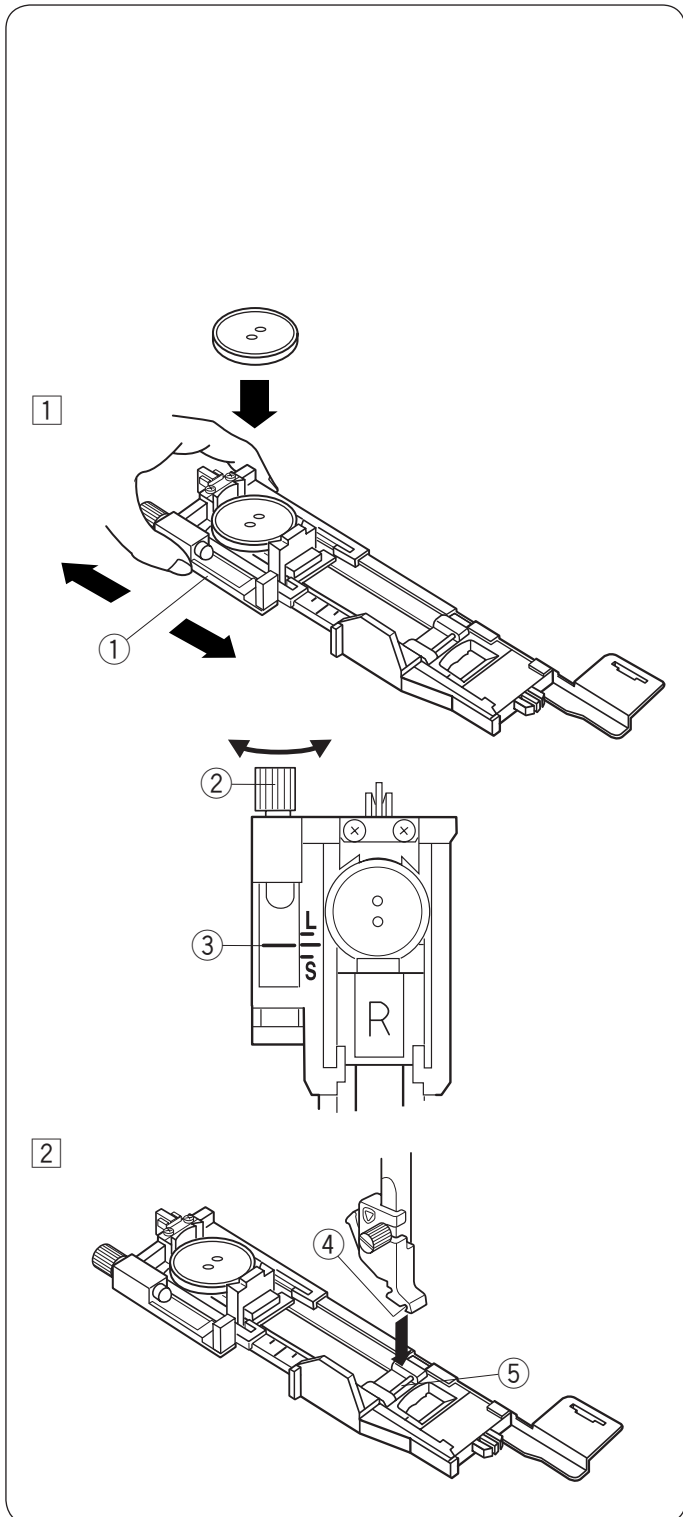

NOTE:

It is sometimes necessary to change buttonhole size to match certain heavy or specific fabrics and threads. Make a test buttonhole on an extra piece of the fabric to check your settings. The preset width of the buttonhole is suited for ordinary buttons. Apply an interfacing to stretch or fine fabrics.

Sewing

- ① Pull the button holder to the back, and place the button in it. Push it together tightly on the button.
 - ① Button holder

NOTE:

Check the length of the test buttonhole, and adjust the buttonhole length if necessary by turning the adjusting screw on the buttonhole foot. To increase the buttonhole length, turn the adjusting screw to move the marker toward "L". To decrease the buttonhole length, turn the adjusting screw to move the marker toward "S".

- ② Adjusting screw
- ③ Marker

- ② Press the needle up/down key to raise the needle. Press the lockout key. Raise the presser foot and attach the automatic buttonhole foot R snapping the pin into the groove of the foot holder. You may lift the presser foot lifter to the extra lifted position when placing the automatic buttonhole foot under the foot holder. Press the lockout key to unlock the machine.
 - ④ Groove
 - ⑤ Pin

3

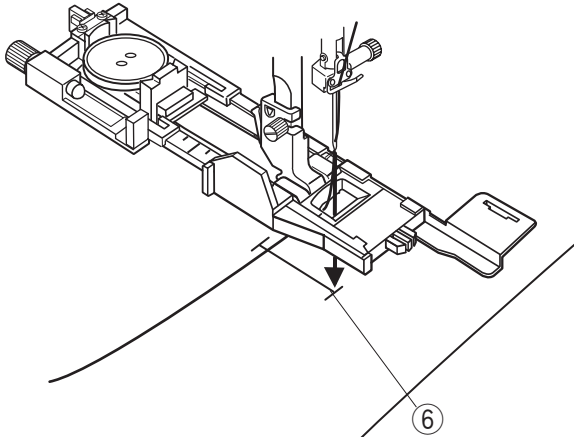

3 Draw the needle thread to the left through the hole of the foot.

Mark the buttonhole position on the fabric and place it under the buttonhole foot. Lower the needle at the starting point by turning the handwheel.

⑥ Starting point

4

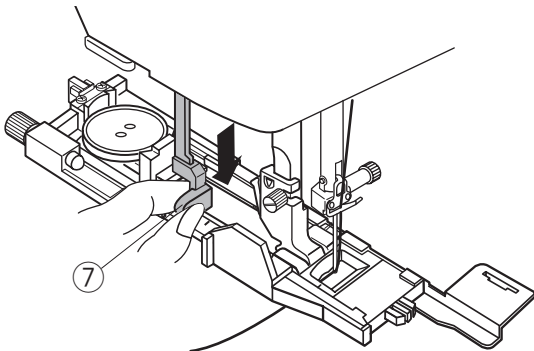

4 Lower the presser foot and pull the buttonhole lever down as far as it will go.

⑦ Buttonhole lever

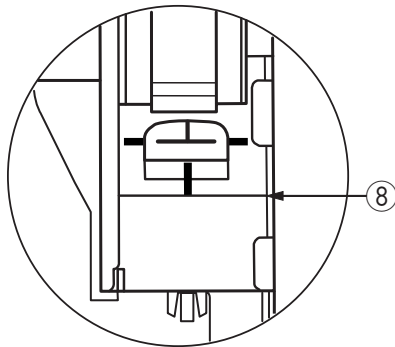

NOTE:

Make sure there is no gap between the slider and front stopper, otherwise the buttonhole will be out of position or there will be a sewing gap.

⑧ No gap

⑨ Starting point

⑩ Sewing gap

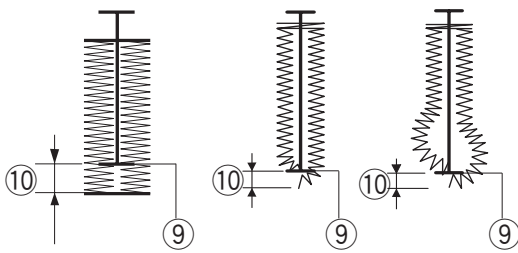

5

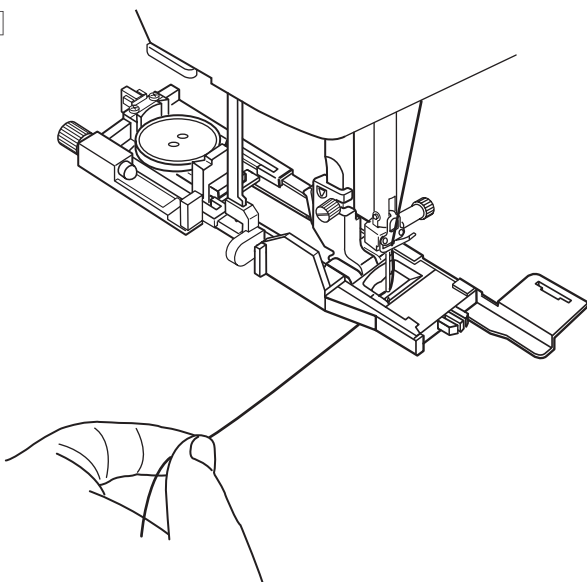

5 Start sewing while pulling the needle thread lightly to the left. After sewing a few stitches, free the thread and continue sewing.

NOTE:

If you start sewing without pulling down the buttonhole lever, the LCD screen will show a warning and the machine will stop after a few stitches. Pull the buttonhole lever down and start sewing.

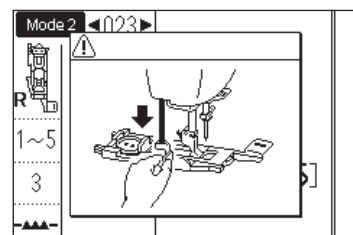

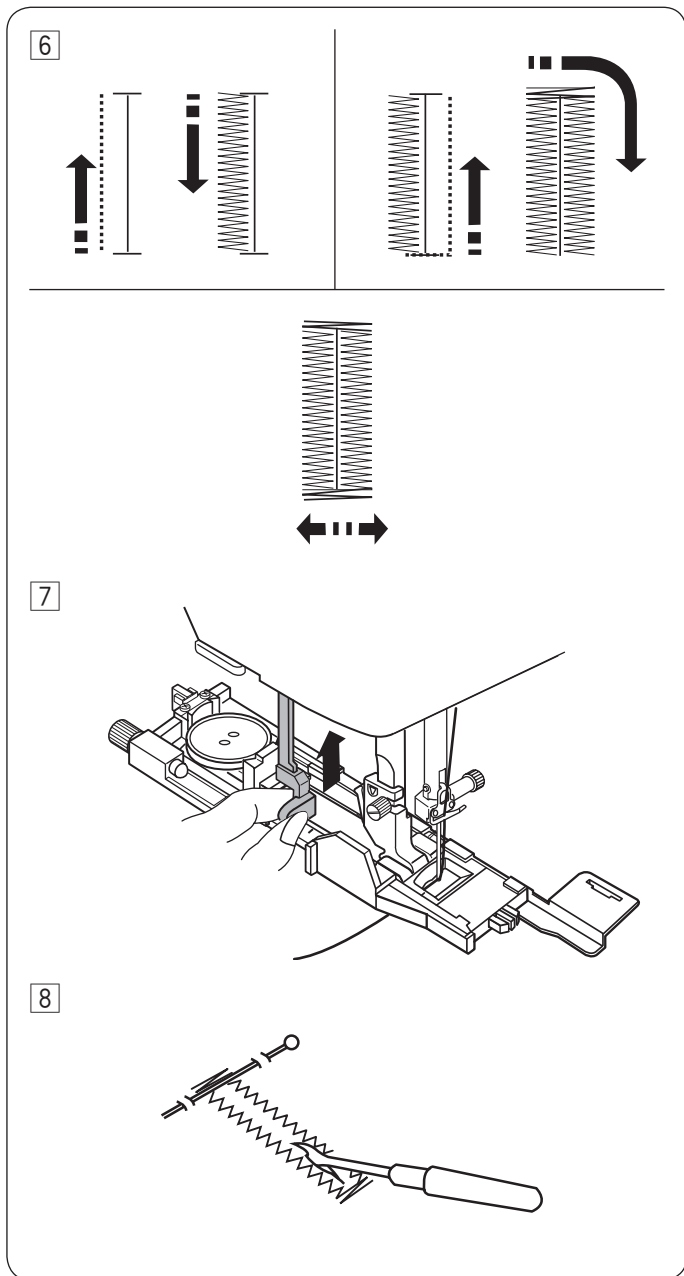

6 The buttonhole is sewn automatically in the sequence shown. When the buttonhole is finished, the machine will stop automatically with the needle in the up position. Press the thread cutter key and remove the fabric.

7 After you finish buttonhole sewing, push the buttonhole lever up as far as it will go.

8 Place a pin just below the bartack at each end to prevent accidentally cutting the threads. Cut the opening with the seam ripper. Use an eyelet puncher* to open a keyhole buttonhole.

Double layer buttonhole

To make a sturdy buttonhole, sew another layer of buttonhole stitches over the previous stitches. After the buttonhole is finished, simply start the machine again.

Do not raise the foot or buttonhole lever.
Do not reselect the pattern.

NOTE:

This function is disabled if Thread Cut after Auto-Lock option is turned on (refer to page 34).

* An eyelet puncher is not included with this machine.

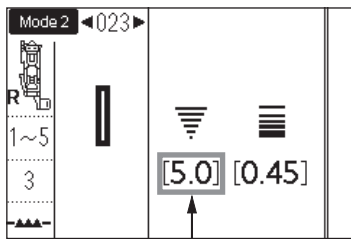

①

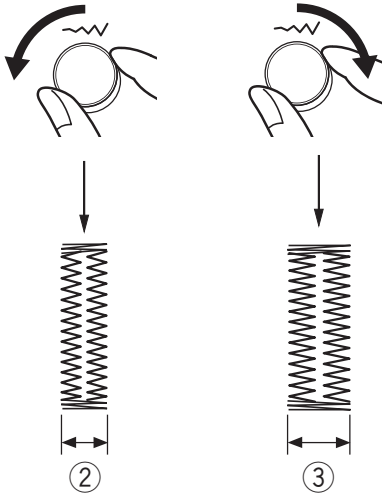

②

③

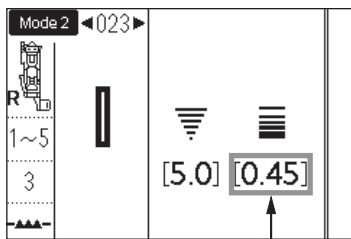

④

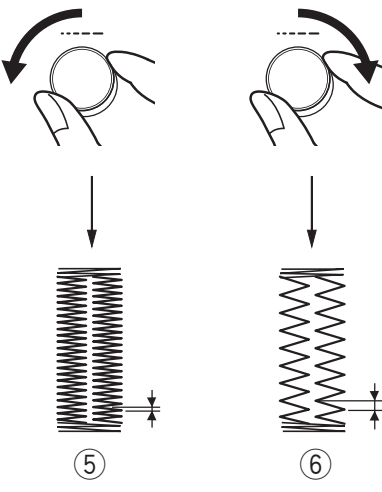

⑤

⑥

Adjusting the buttonhole width

The buttonhole width can be adjusted by turning the stitch width adjusting dial.

Turn the stitch width adjusting dial clockwise to increase the buttonhole width.

Turn the stitch width adjusting dial counterclockwise to decrease the buttonhole width.

- ① Buttonhole width
- ② Narrower buttonhole
- ③ Wider buttonhole

NOTE:

The buttonhole width can be adjusted from 2.6 to 9.0.

Adjusting the buttonhole stitch density

The buttonhole stitch density can be adjusted by turning the stitch length adjusting dial.

Turn the stitch length adjusting dial clockwise to make the buttonhole stitch less dense.

Turn the stitch length adjusting dial counterclockwise to make the buttonhole stitch denser.

- ④ Buttonhole density
- ⑤ Denser buttonhole
- ⑥ Less dense buttonhole

NOTE:

The stitch density can be adjusted from 0.20 to 1.00.

Using the Stabilizer Plate

The stabilizer plate holds and supports the fabric so it is helpful when sewing buttonholes over the hem of thick fabrics.

- 1 Insert the tab of the stabilizer plate ① into the slot ② of the buttonhole foot.

- ① Stabilizer plate
- ② Slot

- 2 Place the button on the button holder of the foot. Attach the buttonhole foot to the machine. Draw the needle thread to the left between the foot and stabilizer plate.

- 3 Place the fabric between the buttonhole foot and stabilizer plate. Lower the needle into the starting point by turning the handwheel. Lower the foot and buttonhole lever. Start the machine while pulling the needle thread lightly to the left. After sewing a few stitches, free the thread and continue sewing.

NOTE:

The sewing procedure is exactly the same as that for 023 sensor (square) buttonholes.

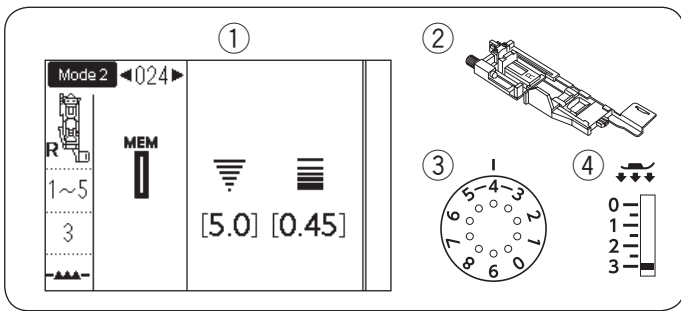

Automatic (square) Buttonhole

- ① Pattern: MODE 2: 024
- ② Presser foot: Automatic buttonhole foot R
- ③ Thread tension: 1-5
- ④ Foot pressure: 3

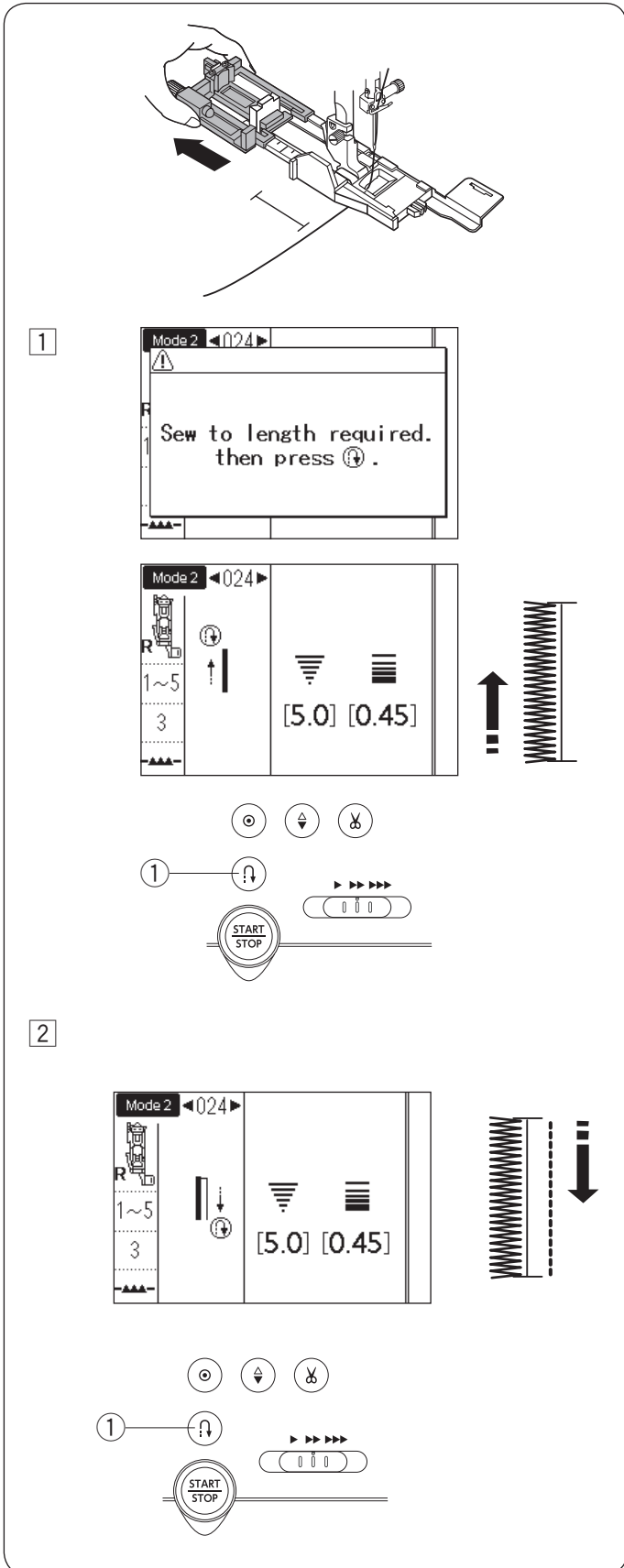

Pull the button holder all the way out.
 Mark the buttonhole position on the fabric.
 Place the fabric under the foot, and lower the needle at the starting point.
 Lower the foot and start sewing while pulling the needle thread lightly to the left. After sewing a few stitches, free the thread and continue sewing.

NOTE:
 You do not need to pull down the buttonhole lever.
 If you want to sew a buttonhole longer than the size permitted by the automatic buttonhole foot R, use satin stitch foot F.

NOTE:
 The buttonhole width can be adjusted from 2.6 to 9.0.
 The stitch density can be adjusted from 0.20 to 1.00.

① Sew the left side up to the required buttonhole length and stop the machine. Then press the reverse key ①.

② Start sewing again, and the machine sews back with a straight stitch. Stop the machine when you reach the starting point. Then press the reverse key ①.

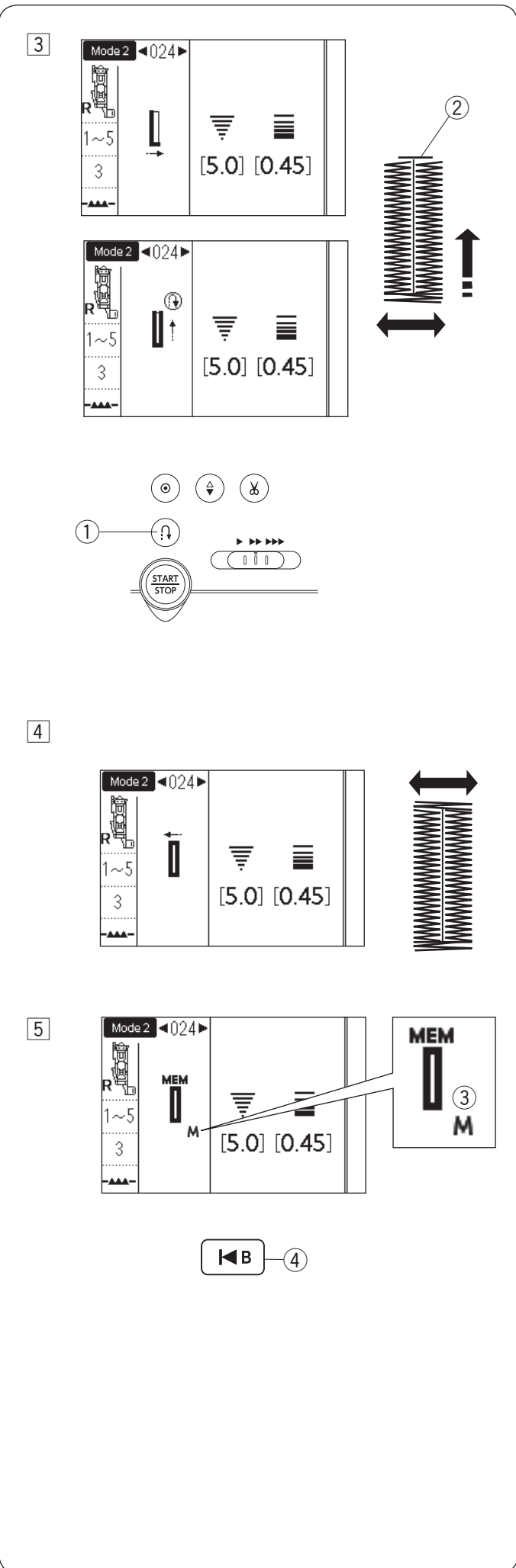

3 Start sewing again, and the machine sews the front bartack and right side of the buttonhole. Stop the machine when you reach the ending point ②. Then press the reverse key ①.

4 Start sewing again, and machine sews the back bartack and locking stitches then stops automatically with the needle in the up position.

5 When the buttonhole is finished, "M" mark ③ will appear. This indicates the buttonhole size has been memorized. To make the next buttonhole, position the fabric and start sewing again. The machine sews another buttonhole identical to the first one then stops automatically. To sew another buttonhole in a different size, press the start/over key ④.

NOTE:
To cut the buttonhole opening, refer to the instructions on page 60.

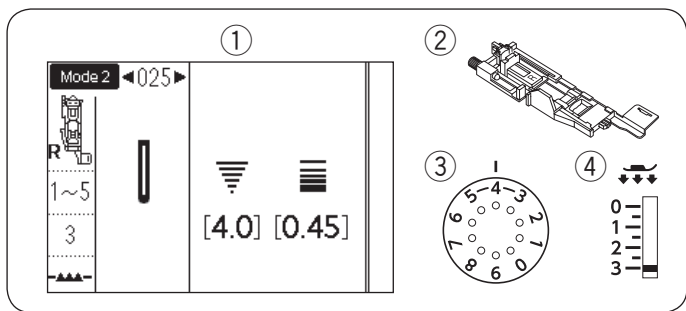

Round End and Fine Fabric Buttonholes

- ① Pattern: MODE 2: 025
MODE 2: 026
- ② Presser foot: Automatic buttonhole foot R
- ③ Thread tension: 1-5
- ④ Foot pressure: 3

The sewing procedure is the same as that of 023 square (sensor) buttonhole (refer to pages 58-60).

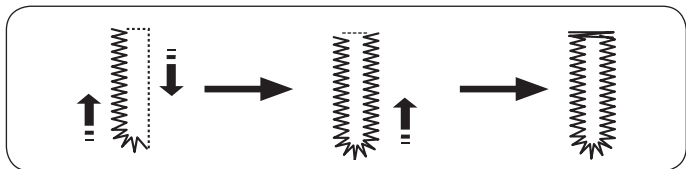

NOTE:

The buttonhole width can be adjusted from 2.6 to 9.0.
The stitch density can be adjusted from 0.20 to 1.00.

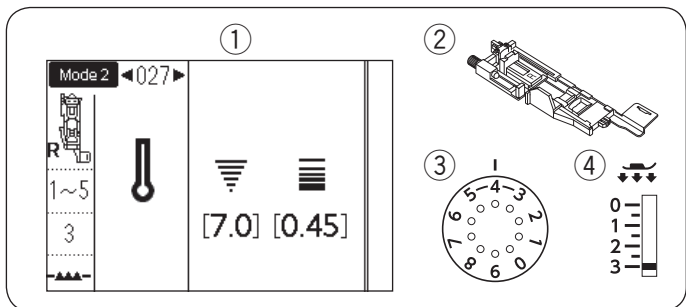

Keyhole Buttonholes

- ① Pattern: MODE 2: 027-029
- ② Presser foot: Automatic buttonhole foot R
- ③ Thread tension: 1-5
- ④ Foot pressure: 3

The sewing procedure is the same as 023 square (sensor) buttonhole (refer to pages 58-60).

Use an eyelet punch to open the keyhole buttonhole.

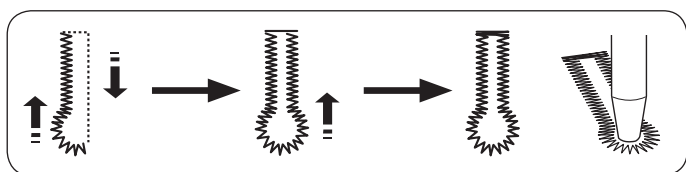

NOTE:

The buttonhole width can be adjusted from 5.6 to 9.0.
The stitch density can be adjusted from 0.20 to 1.00.

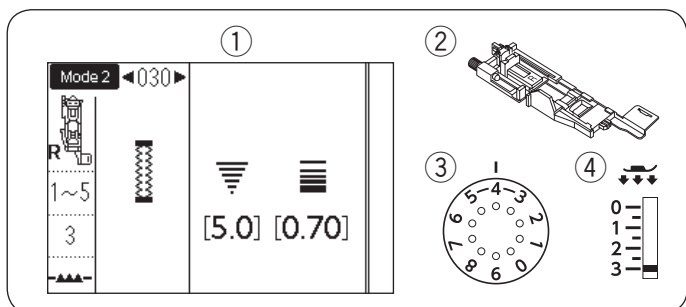

Stretch Buttonhole

- ① Pattern: MODE 2: 030
- ② Presser foot: Automatic buttonhole foot R
- ③ Thread tension: 1-5
- ④ Foot pressure: 3

The sewing procedure is the same as that of 023 square (sensor) buttonhole (refer to pages 58-60).

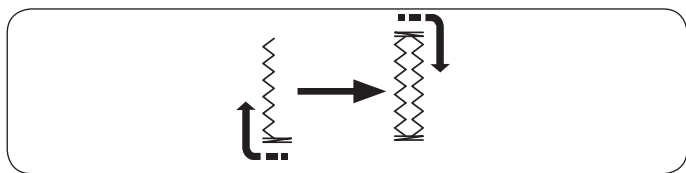

NOTE:

The buttonhole width can be adjusted from 2.6 to 9.0.
The stitch density can be adjusted from 0.50 to 1.00.

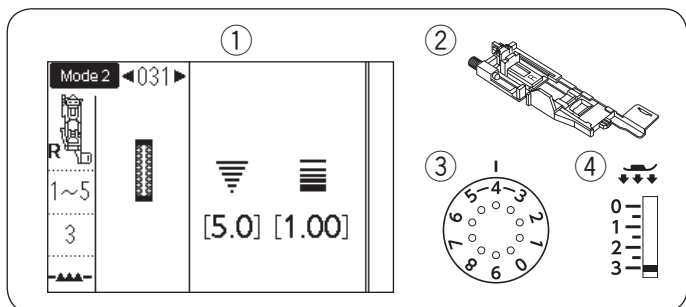

Knit Buttonhole

- ① Pattern: MODE 2: 031
- ② Presser foot: Automatic buttonhole foot R
- ③ Thread tension: 1-5
- ④ Foot pressure: 3

The sewing procedure is the same as that of 023 square (sensor) buttonhole (refer to pages 58-60).

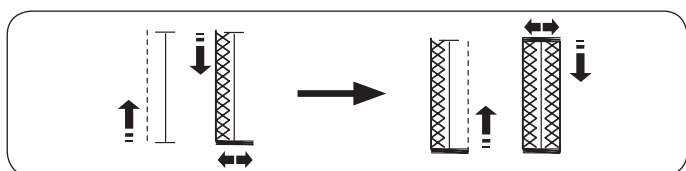

NOTE:

The buttonhole width can be adjusted from 2.6 to 9.0.
The stitch density can be adjusted from 0.70 to 1.20.

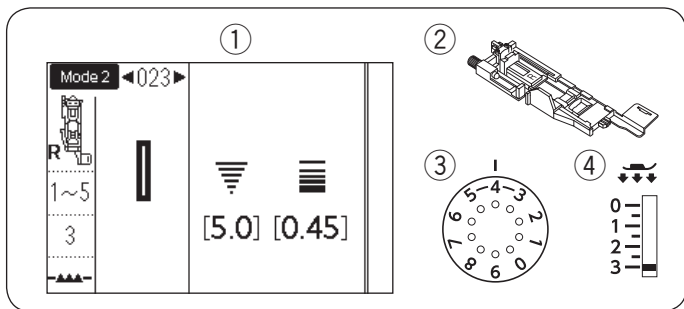

Corded Buttonhole

- ① Pattern: MODE 2: 023
- ② Presser foot: Automatic buttonhole foot R
- ③ Thread tension: 1-5
- ④ Foot pressure: 3

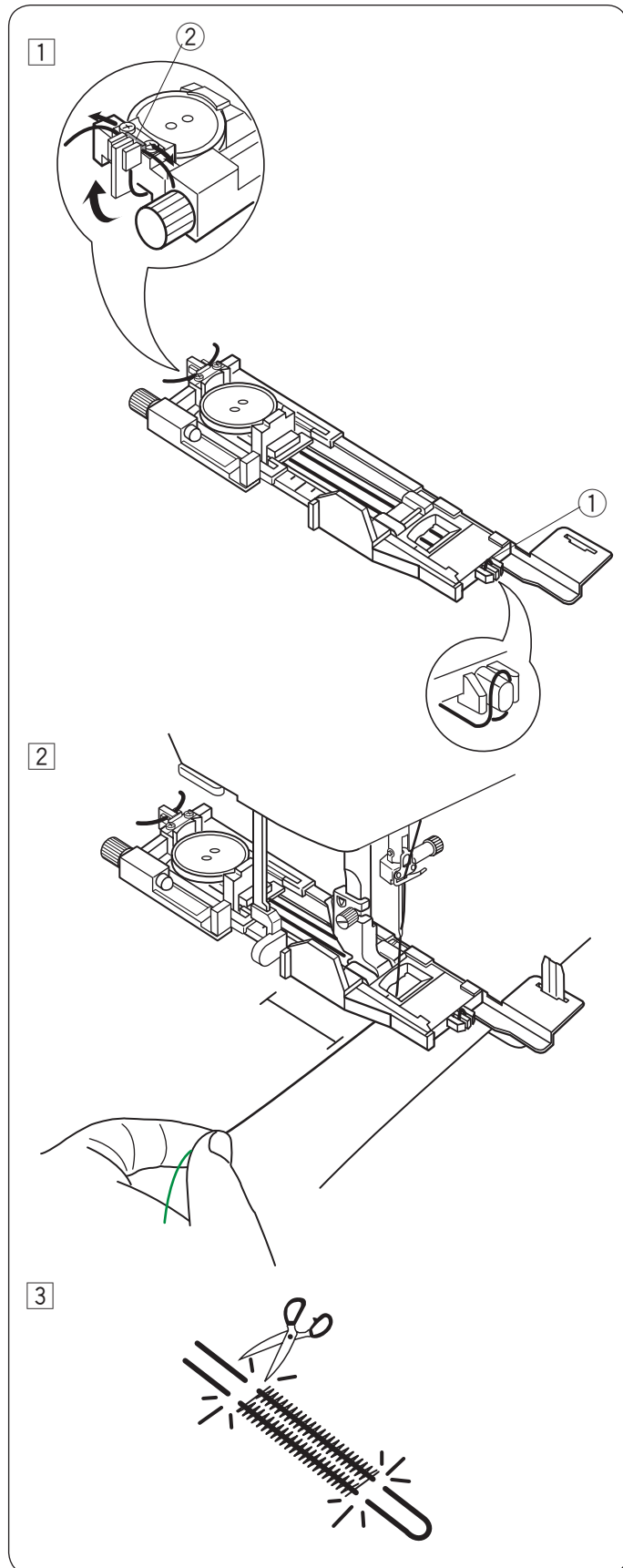

To sew a corded buttonhole, follow the same procedure as for 023 square (sensor) buttonhole.

Select pattern 023 in mode 2.

- ① Place the button on the button holder on the buttonhole foot.
Hook a filler cord on the spur on the front of the foot. Bring the ends of cord toward the back and under the foot.
Bring up the ends of the cord and insert both ends between the ribs and metal plate.
 - ① Spur
 - ② Metal plate
 Set the stabilizer plate as necessary and attach the buttonhole foot.

- ② Lower the needle into the fabric where the buttonhole will start.
Lower the foot and buttonhole lever.
Pull the needle thread lightly to the left.
Start the machine to sew the buttonhole over the cord.
The machine stops automatically when finished.
Remove the fabric from the machine and cut the sewing threads only.

- ③ Cut the filler cord at both ends as close to the buttonhole as possible.

NOTE:
Set the stitch width in accordance with the thickness of the cord used.
To cut the buttonhole opening, refer to the instructions on page 60.

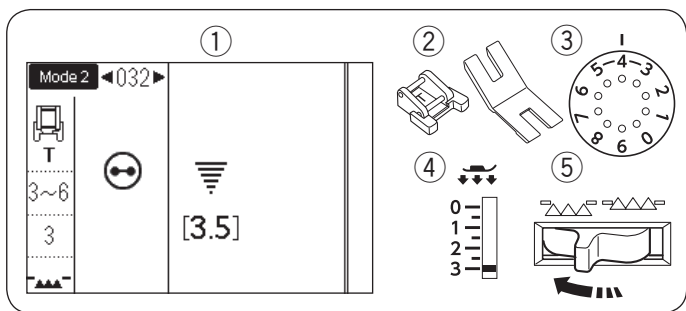

Button Sewing

① Pattern:	MODE 2: 032
② Presser foot:	Button sewing foot T Button shank plate
③ Thread tension:	3-6
④ Foot pressure:	3
⑤ Feed dog:	Lowered

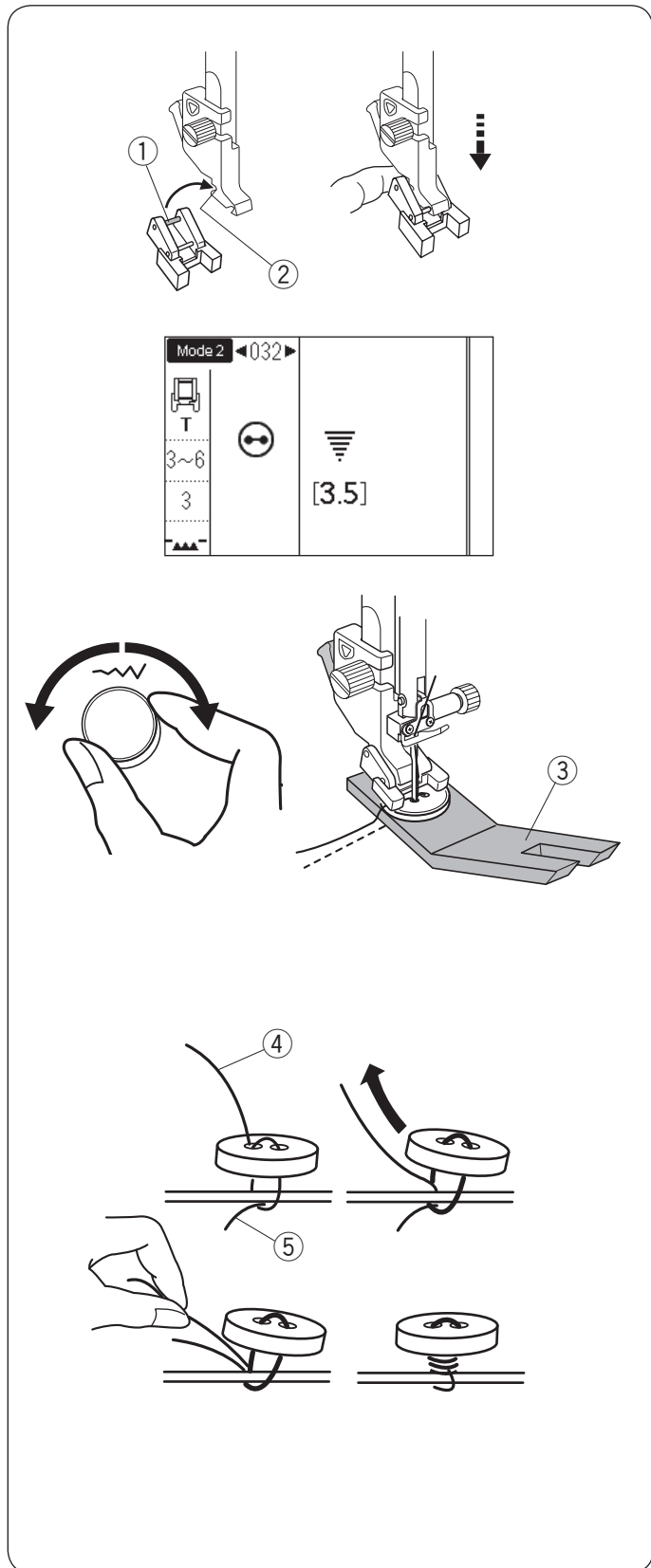

Attaching the button sewing foot T

Make sure to press the lockout key to lock the machine. Insert the rear pin on the foot into the rear groove of the foot holder.

- ① Rear pin
- ② Rear groove

Gently lower the presser bar while holding the foot with your fingers.

Press the lockout key to unlock the machine.

Sewing

Lower the feed dog.

Place a button on the fabric and lower the needle into the left hole of the button by turning the handwheel with your hand.

Insert the button shank plate under the button.

Lower the foot to hold the button in place, aligning the direction of the button.

- ③ Button shank plate

Raise the needle by turning the handwheel until the needle bar swings to the right.

Turn the stitch width adjusting dial so the needle enters into the right hole of the button.

Start sewing and continue until the machine stops automatically.

Cut the all threads leaving at least 10 cm (4") tails. Remove the fabric from the machine.

Pass the needle thread at the end of stitching through the left hole in the button, between the button and fabric. Pull the needle thread to bring the bobbin thread up to the right side of the fabric.

- ④ Needle thread at the end
- ⑤ Bobbin thread

Wind the threads to form a shank and knot them together.

NOTE:

- Do not use the thread cutter key to cut the threads. Otherwise, you cannot tie the threads.
- The button shank plate cannot be used if the button is too thick.

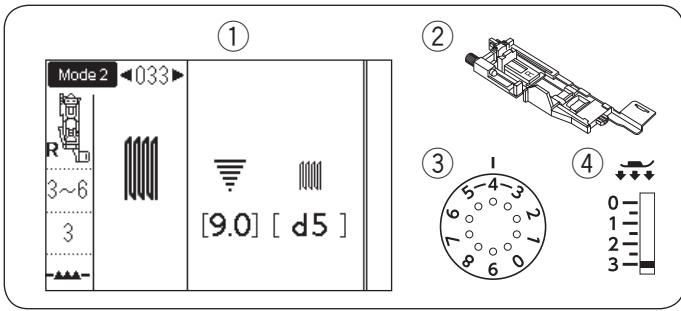

Darning

① Pattern:	MODE 2: 033
② Presser foot:	Automatic buttonhole foot R
③ Thread tension:	3-6
④ Foot pressure:	3

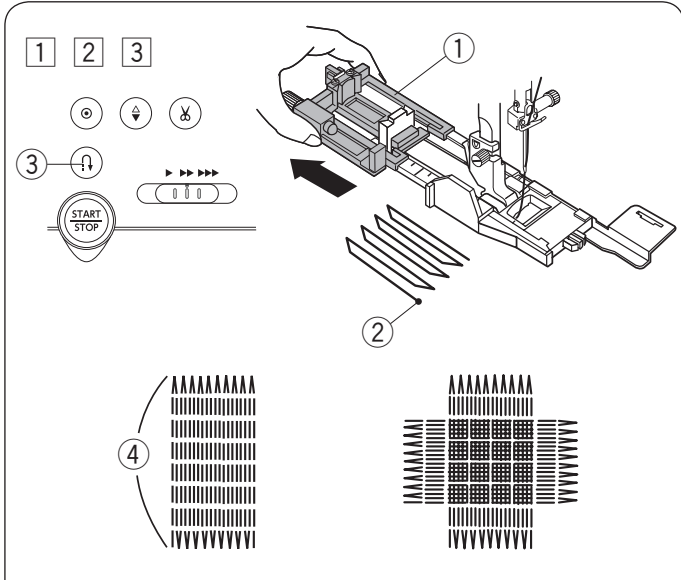

- ① Attach the automatic buttonhole foot R and pull the button holder all the way out. Place the fabric under the foot, and lower the needle at the starting point. Then lower the foot.
 - ① Button holder
 - ② Starting point
- ② Start the machine and sew to the required length, then press the reverse key. This sets the darning length. Continue sewing until the machine stops automatically.
 - ③ Reverse key
 - ④ Required length
- ③ Sew another layer of darning over the first layer, at a right angle to it.

NOTE:

The maximum darning length is 2 cm (3/4") and the maximum width is 0.9 cm (3/8").

To sew the same size darning

When finished sewing, the "M" mark ⑤ will appear. This indicates the darning size has been memorized. Simply start the machine to sew another darning in the same size.

To sew the next darning in a different size, press the startover key.

- ⑥ Startover key

To sew a shorter darning

Sew the first line to the required length ④ and stop the machine.

Press the reverse key ③ and start the machine again. The machine will sew the rest of the darning and stop automatically.

To adjust the evenness of darning stitches

You can correct unevenness of darning stitches by turning the stitch length adjusting dial.

If the left corner is lower than the right side, turn the dial counterclockwise to correct it (d4-d1).

If the right corner is lower than the left side, turn the dial clockwise to correct it (d6-d9).

NOTE:

The shape can be adjusted within d1 to d9 (default setting is d5).

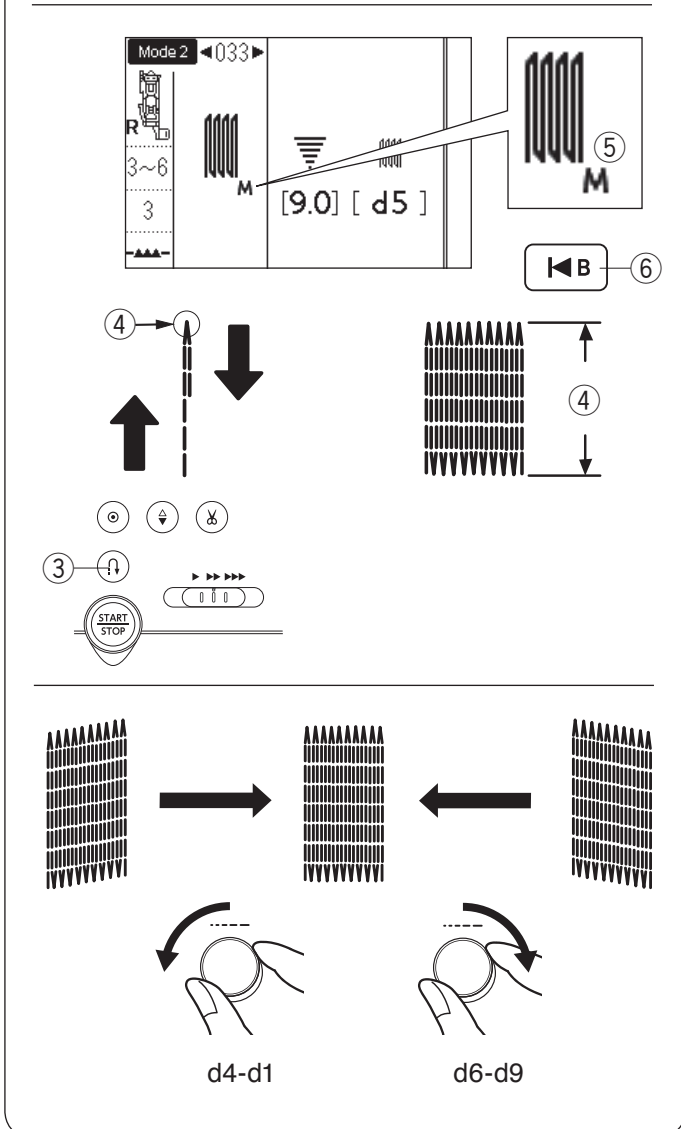

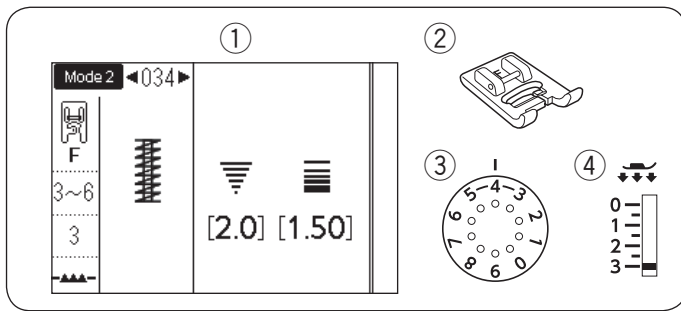

Tacking

- ① Pattern: MODE 2: 034
- ② Presser foot: Satin stitch foot F
- ③ Thread tension: 3-6
- ④ Foot pressure: 3

Tacking is used to reinforce pockets, crotch seams and belt carriers where extra strength is needed.

Sewing

Lower the needle at the starting point. Lower the foot and sew until the machine stops automatically. The machine will sew a tacking 1.5 cm (9/16") long automatically.

- ① Tacking
- ② Starting point
- ③ 1.5 cm (9/16")

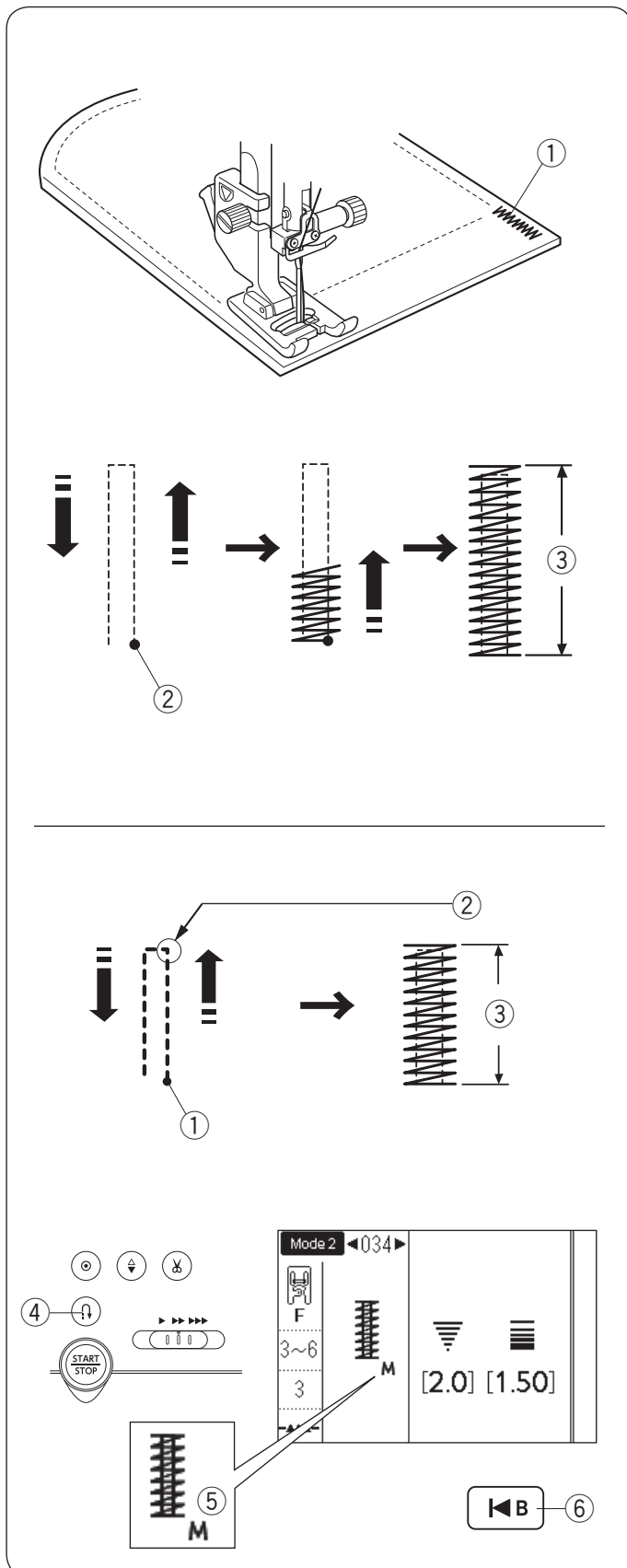

Sewing a shorter tack

To sew a tack shorter than 1.5 cm (9/16"), first stop the machine after sewing the required length, and then press the reverse key.

The required length has been determined. Continue sewing until the machine stops automatically.

- ① Starting point
- ② Required length
- ③ Tack length
- ④ Reverse key

Sewing the same size tack

When finished sewing, the "M" mark ⑤ will appear. This indicates the tacking size has been memorized. To sew another tack in the same size, simply start the machine and it will stop automatically when finishing sewing.

Sewing the tack at a different size

To sew the next tack at a different size, press the start/over key and start sewing from the beginning.

- ⑥ Start/over key

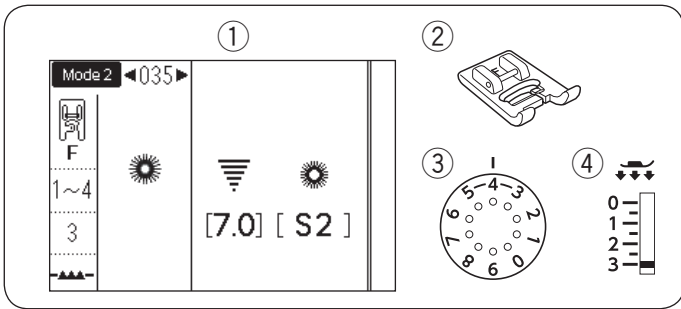

Eyelet

- | | |
|-------------------|---------------------|
| ① Pattern: | MODE 2: 035 |
| ② Presser foot: | Satin stitch foot F |
| ③ Thread tension: | 1-4 |
| ④ Foot pressure: | 3 |

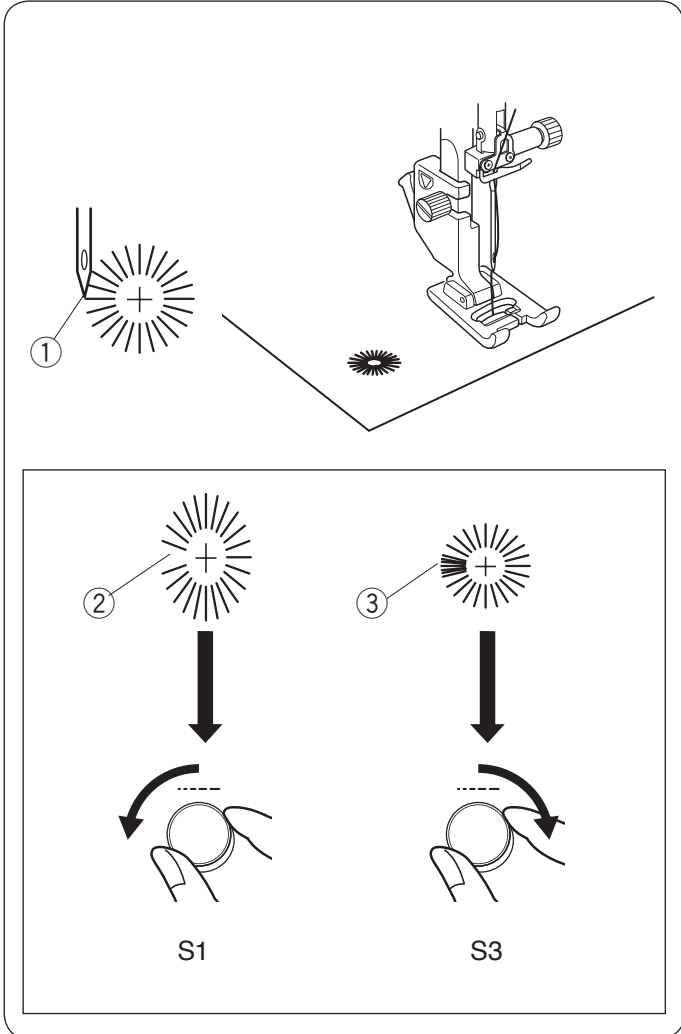

The eyelet is used for belt holes, etc.
Attach the satin stitch foot F.

To sew:

Place the garment under the foot and lower the needle to the starting point.

Sew until the machine stops automatically.

- ① Starting point

Open the eyelet with an awl, puncher or pointed scissors.

To correct the shape of an eyelet:

If the eyelet is open ②, turn the stitch length adjusting dial counterclockwise (S1).

If the eyelet overlaps ③, turn the stitch length adjusting dial clockwise (S3).

NOTE:

The stitch width cannot be adjusted.

The shape can be adjusted within S1 to S3 (default setting is S2).

DECORATIVE STITCHES

Applique

- ① Pattern: MODE 1: 7 or MODE 2: 036-049
- ② Presser foot: Satin stitch foot F or
Open-toe satin stitch foot F2
- ③ Thread tension: 3-6
- ④ Foot pressure: 2

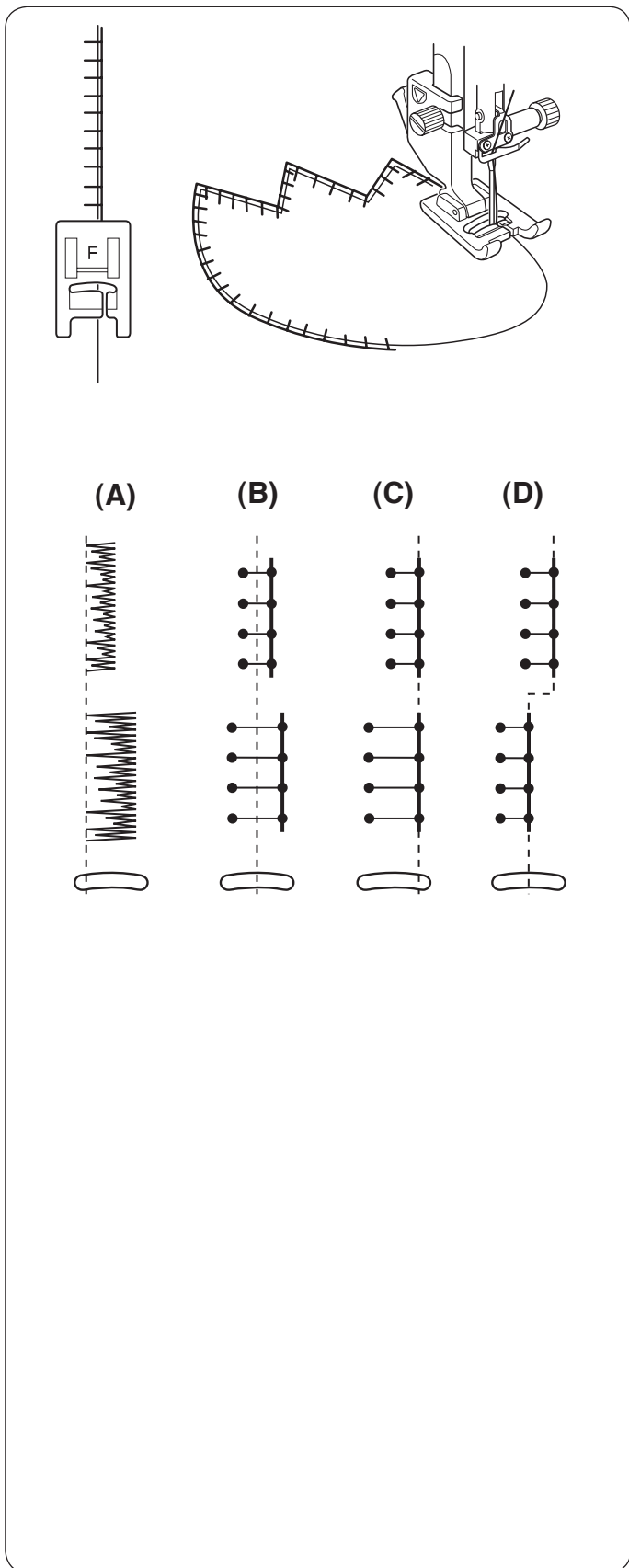
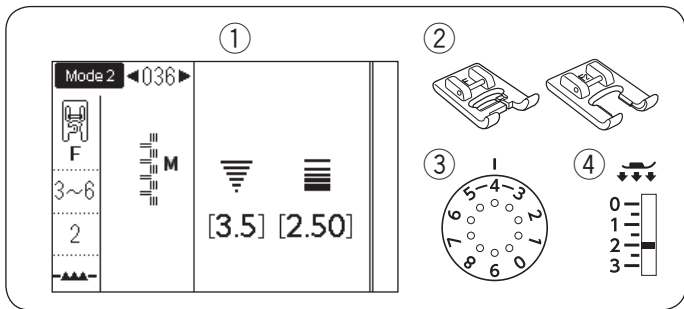

Place an applique on the fabric and baste it in place or use a fusible web to secure the applique in place. Guide the applique fabric, so that the needle falls off the edge of the applique when the needle swings to the right.

Adjusting stitch width or needle drop position

(A): The pattern number 051 in mode 2 has a fixed left needle drop position. When you change the stitch width, the right needle drop position will change.

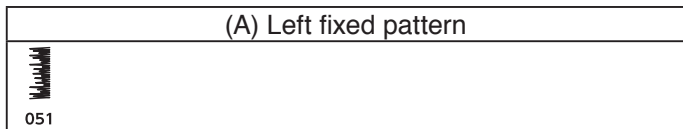

(B): The patterns number 036 to 038, 050 and 052 in mode 2 have a fixed center needle drop position. The stitch width changes symmetrically.

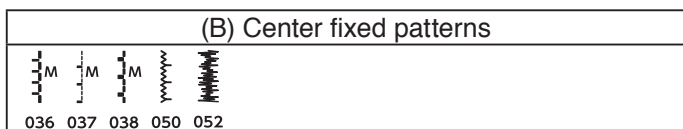

(C): The patterns number 039 to 047 in mode 2 have a fixed right needle drop position. When you change the stitch width, the left needle drop position will change.

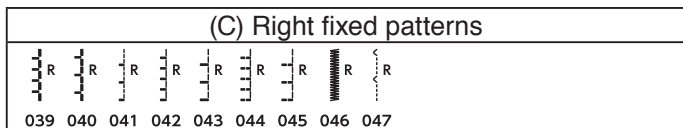

(D): The patterns number 048 to 049 in mode 2 have a variable position. When you change the stitch width, the stitch width will not change but the position of the stitch pattern.

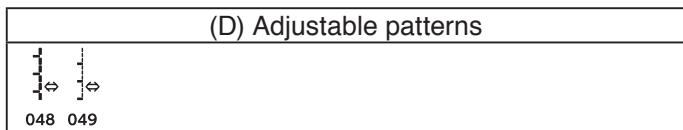

NOTE:

The stitch width of the pattern 048 (mode 2) is 3.5.
The stitch width of the pattern 049 (mode 2) is 2.0.

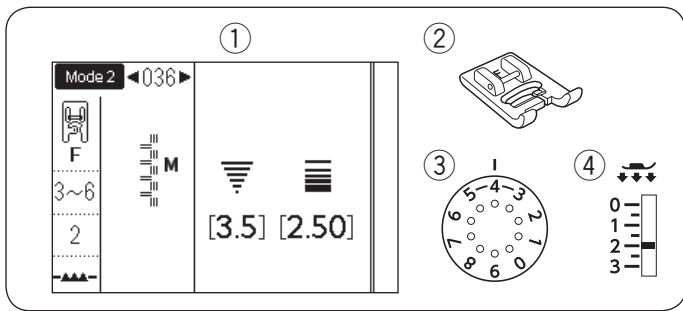

Fringing

- ① Pattern: MODE 2: 036
- ② Presser foot: Satin stitch foot F
- ③ Thread tension: 3-6
- ④ Foot pressure: 2

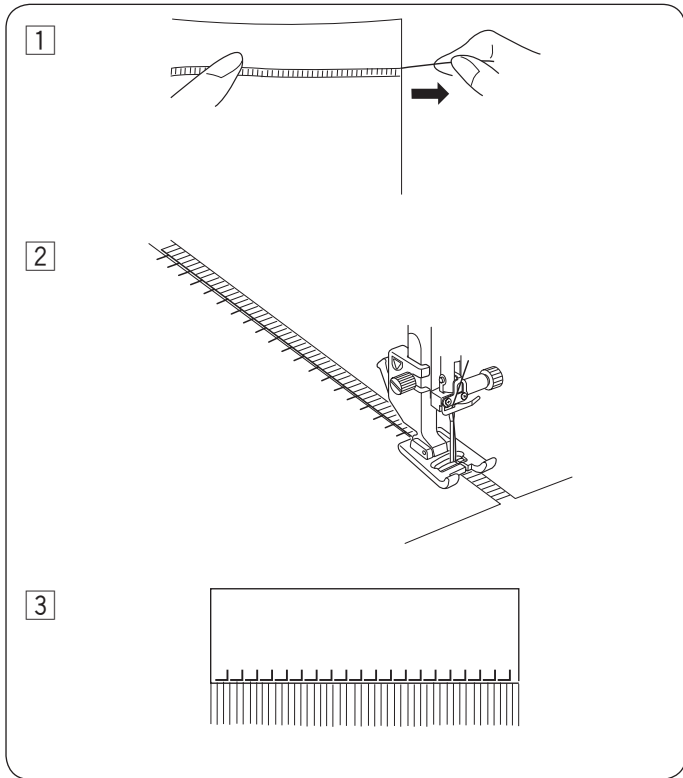

Fringing adds a special touch on table linens and shawls. Choose a firm, woven fabric like linen where threads can be removed easily.

- ① Carefully cut the fabric on the grain. Remove a single strand of yarn or thread where the fringing is to begin.
- ② Sew down the left side so the right hand stitches fall in the open space.
- ③ Remove all excess yarn located to the right of the stitching and create a fringe.

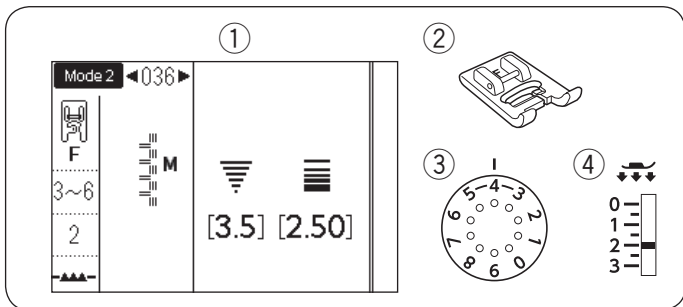

Drawn Work

- ① Pattern: MODE 2: 036
- ② Presser foot: Satin stitch foot F
- ③ Thread tension: 3-6
- ④ Foot pressure: 2

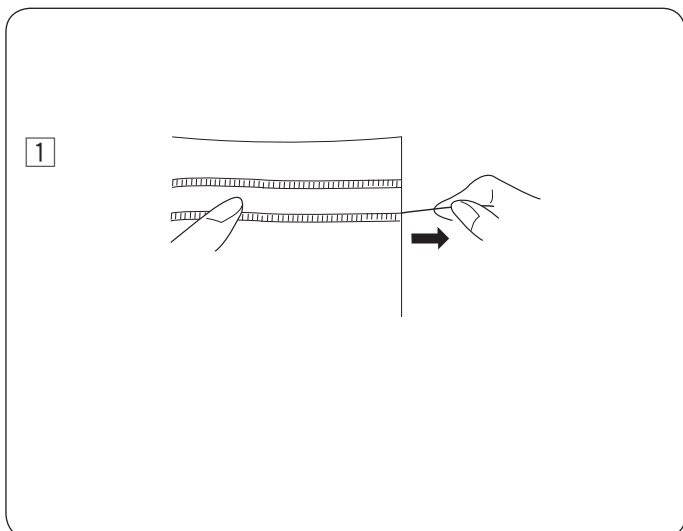

Drawn work uses the same method as fringing. Choose a firm, woven fabric like linen where threads can be removed easily.

- ① Carefully cut the fabric on the grain. Determine the width of the drawn work and remove one strand of yarn or fabric thread at each end.

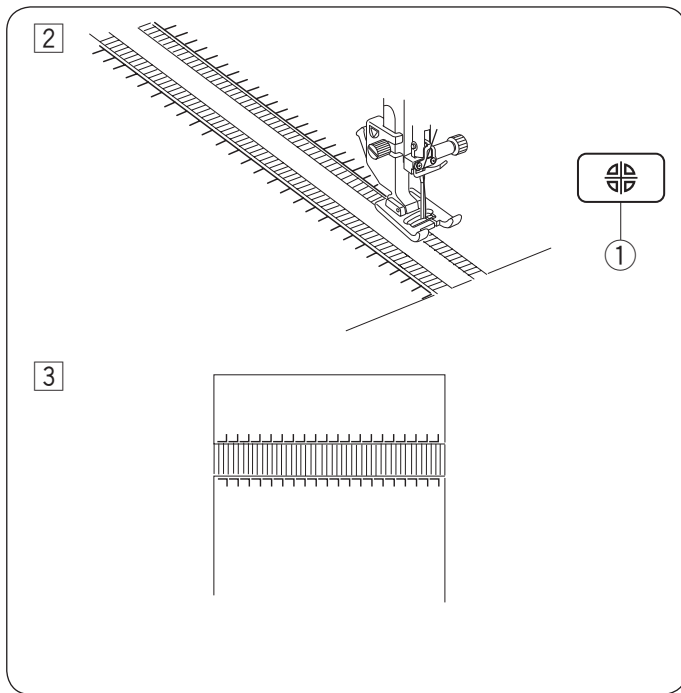

- ② Sew down the left side, guiding the fabric so the right hand stitches fall in open space. After finishing the left side, press the mirror image key. Sew down the other side (refer to page 86 for mirror image sewing).
 - ① Mirror image key

- ③ Remove the yarn or fabric threads between the stitching.

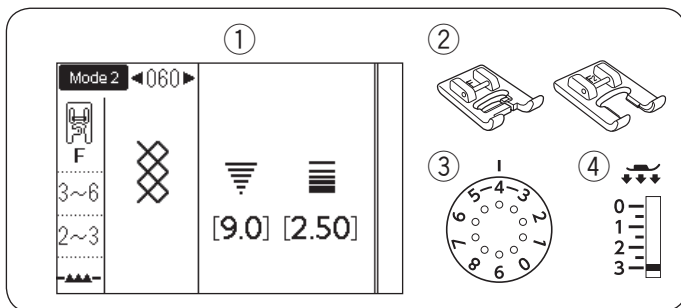

Smocking

- | | |
|-------------------|---|
| ① Pattern: | MODE 2: 060 |
| ② Presser foot: | Satin stitch foot F or
Open-toe satin stitch foot F2 |
| ③ Thread tension: | 3-6 |
| ④ Foot pressure: | 2-3 |

The following stitch patterns can also be used for smocking.

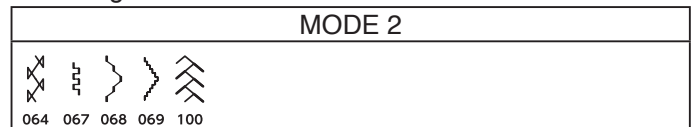

Choose a soft, lightweight fabric such as batiste, gingham or challis. Cut the fabric three times wider than the projected width.

Sew rows of straight stitches, 1.2-1.5 cm (1/2") apart with the stitch length "3.0" to "5.0" and thread tension dial at "1" to across the area to be smocked.

- ① 1.2-1.5 cm (1/2")
- ② Knotted thread

Tie the threads along one edge. From the other edge, pull the bobbin threads to distribute the gathers evenly.

NOTE:

Pull up the bobbin thread and draw a 10 cm (4") thread tail to the back before starting to sew.
Use the thread cutter on the face plate.

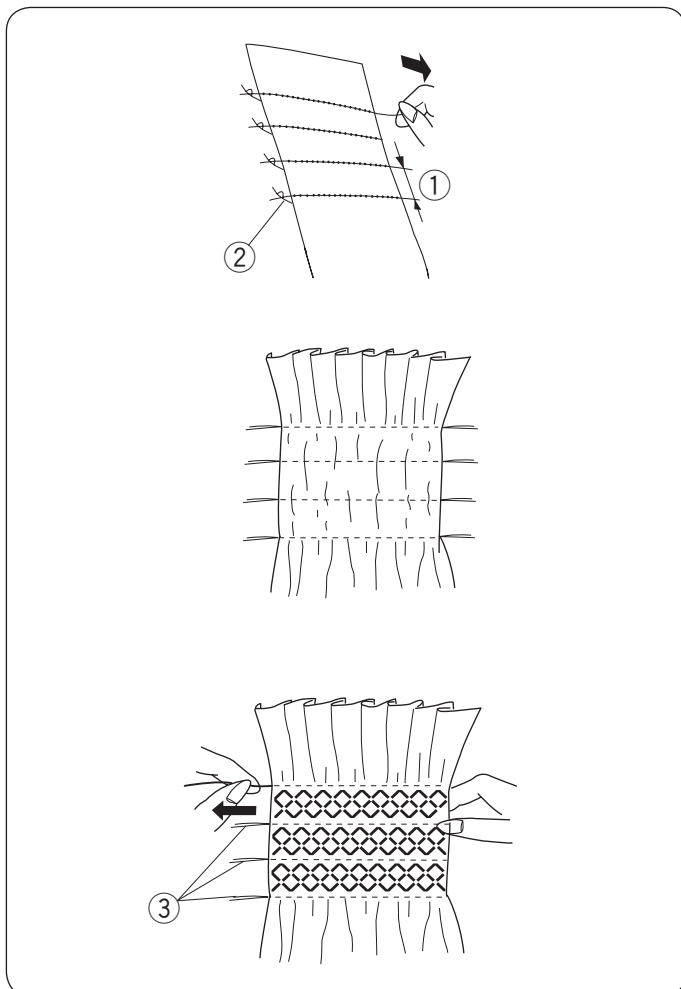

Select a smocking stitch and return the thread tension dial to 3-6.

Sew the smocking stitches between the gathered rows.

Remove the straight stitches between the gathered rows.

- ③ Straight stitch

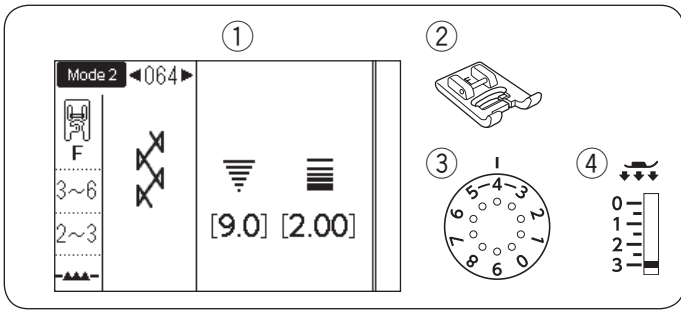

Fagoting

- ① Pattern: MODE 2: 064
- ② Presser foot: Satin stitch foot F
- ③ Thread tension: 3-6
- ④ Foot pressure: 2-3

The following stitch patterns can also be used for fagoting.

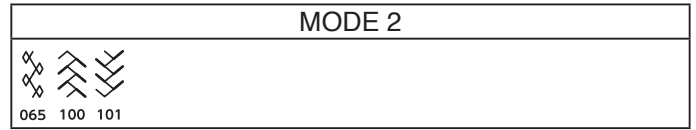

Use this stitch to join two pieces of fabric to create an open work appearance and add design interest.

Fold under each fabric edge 1.5 cm (5/8") and press. Pin the two edges to paper or tear away backing 0.3 cm (1/8") apart.

- ① 0.3 cm (1/8")
- ② Paper

Sew slowly, guiding the fabric so the needle catches the folded edge on each side.

After finishing sewing, tear away the paper.

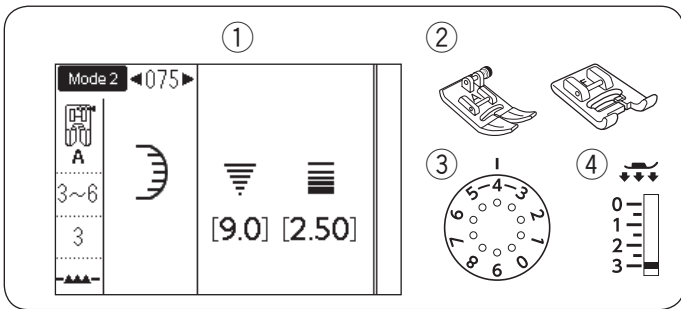
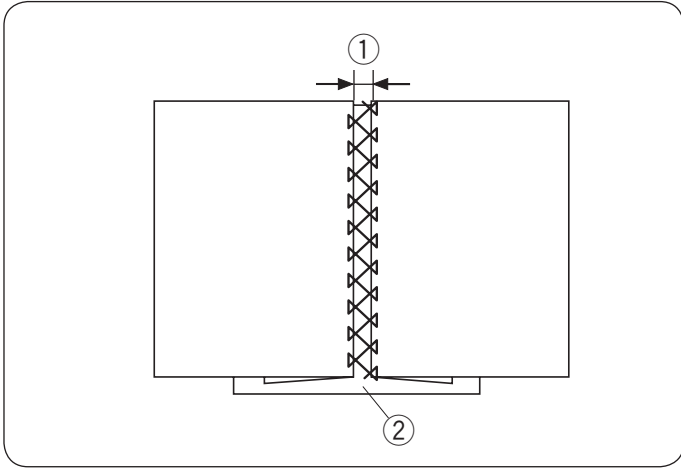

Scallop

- ① Pattern: MODE 2: 075
- ② Presser foot: Zigzag foot A or Satin stitch foot F
- ③ Thread tension: 3-6
- ④ Foot pressure: 3

The following stitch patterns can also be used for scallop.

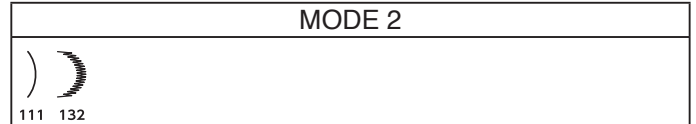

Sew scallops 1 cm (3/8") from the fabric edge.

Trim the allowance close to the stitches.

Make sure not to cut the stitches.

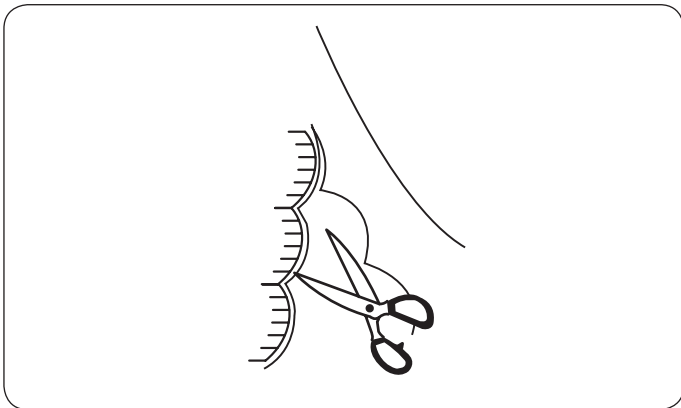

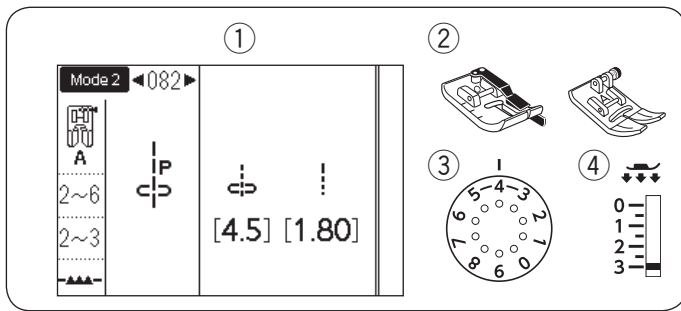

Patchwork Piecing

- ① Pattern: MODE 1: 4 or MODE 2: 082-084
- ② Presser foot: 1/4" seam foot O or Zigzag foot A
- ③ Thread tension: 2-6
- ④ Foot pressure: 2-3

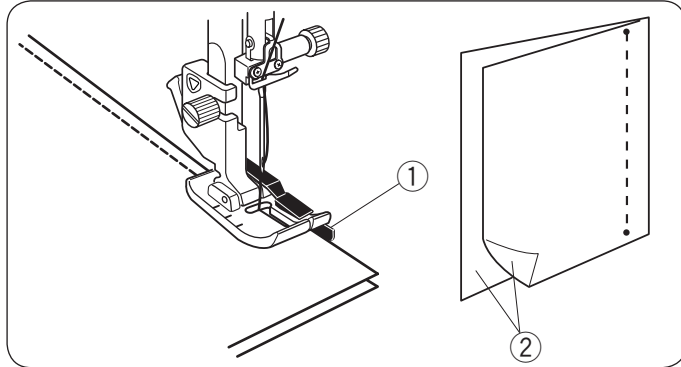

Patterns 082 to 084 in mode 2 are special stitches for seaming patchwork pieces.

Patterns 083 and 084 are for patchwork piecing with 1/4" and 7 mm seam allowances respectively.

Use the 1/4" seam foot O.

Place the patchwork pieces right sides together. Sew while guiding the edge of fabric along the guide.

- ① Guide
- ② Right side of the fabric

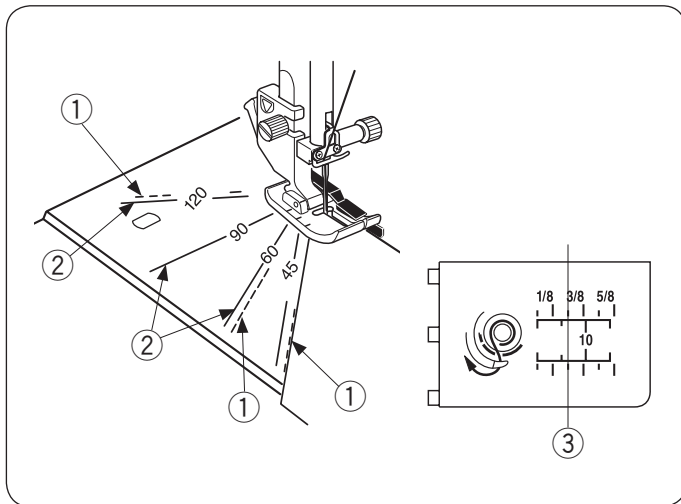

Angle Scales on the Needle Plate

You can easily seam patchwork pieces at the desired angle without marking, by using the angle scales on the needle plate.

The angle scales are marked at 45, 60, 90 and 120 degrees.

Use the broken lines when piecing the patchwork pieces with the 1/4" seam foot O as illustrated.

- ① Broken line

NOTE:

Use the solid lines when piecing the patchwork pieces with the zigzag foot A. Align the edge of the fabric to the 1/4" seam guide line.

- ② Solid line
- ③ 1/4" seam guide line

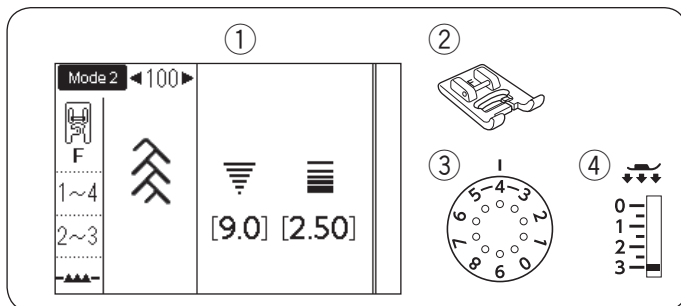

Patchwork

- ① Pattern: MODE 1: 9 or MODE 2: 100
- ② Presser foot: Satin stitch foot F
- ③ Thread tension: 1-4
- ④ Foot pressure: 2-3

The following stitch patterns can also be used for patchwork.

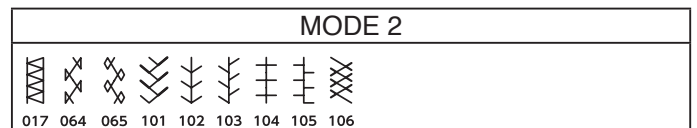
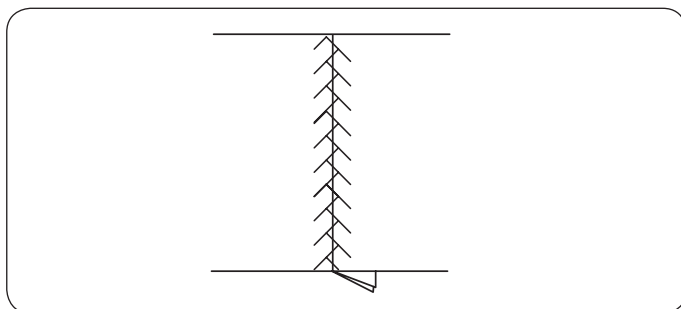

Open the seam flat with the right side up and sew patchwork stitch along the seam line.

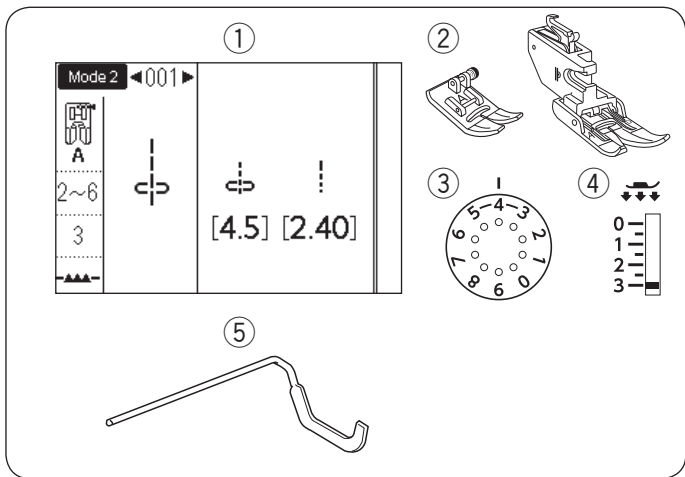

Quilting

- ① Pattern: MODE 1: 1 or MODE 2: 001
- ② Presser foot: Zigzag foot A or Dual feed foot AD
- ③ Thread tension: 2-6
- ④ Foot pressure: 3
- ⑤ Quilter

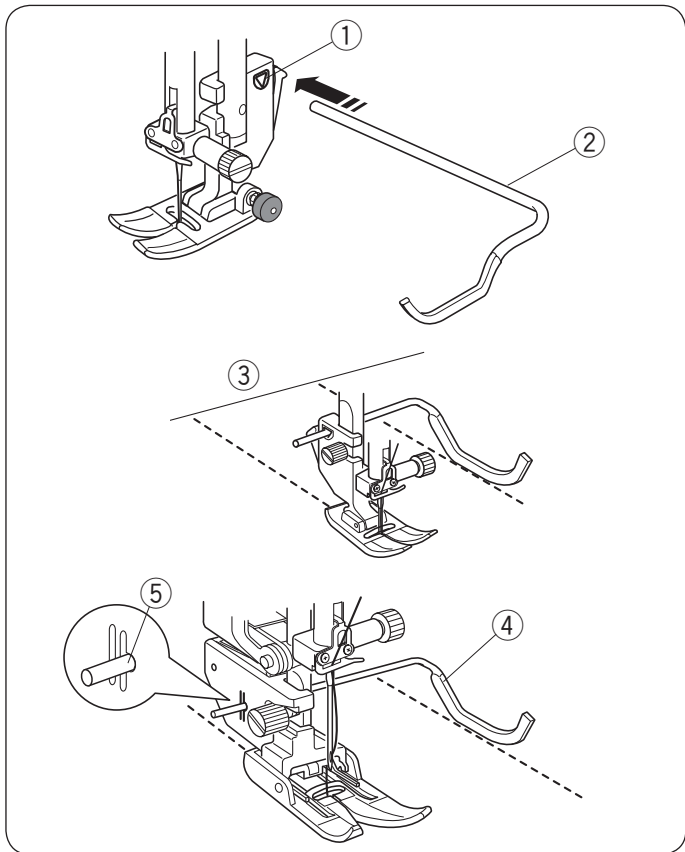

Attaching the quilting guide bar

The quilting guide bar is helpful when sewing parallel, evenly spaced rows of stitching.

Insert the quilting guide bar into the opening and slide the quilting guide bar to the position according to the desired space between seams.

- ① Opening on the foot holder
- ② Quilting guide bar
- ③ Space between seams

Sewing

Sew while tracing the previous seam with the quilting guide bar.

Quilting guide bar for dual feed foot

Insert the quilting guide bar into the hole in the rear of the foot holder.

Shift the quilting guide bar to the desired spacing.

- ④ Quilting guide bar
- ⑤ Hole

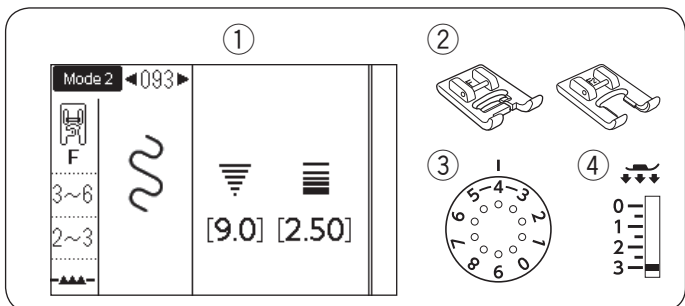

Stippling

- ① Pattern: MODE 2: 093
- ② Presser foot: Satin stitch foot F or Open-toe satin stitch foot F2
- ③ Thread tension: 3-6
- ④ Foot pressure: 2-3

The following stitch patterns can also be used for stippling.

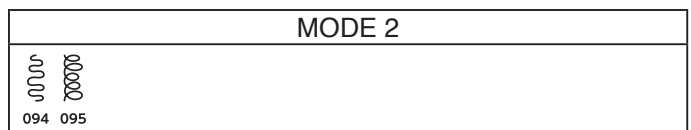
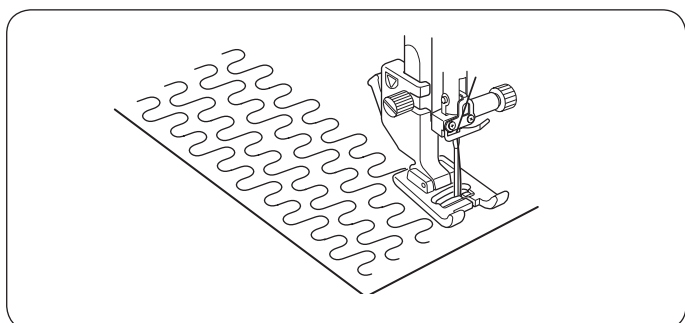

A pre-programmed stippling stitch is a fast and easy method to quilt small areas.

Place a quilt layer and sew.

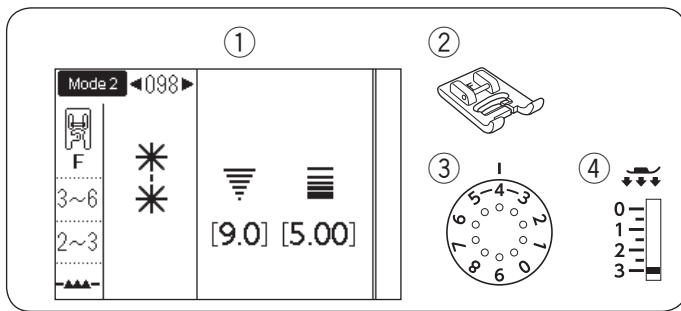

Clasp Stitch

- ① Pattern: MODE 2: 098 or 099
- ② Presser foot: Satin stitch foot F
- ③ Thread tension: 3-6
- ④ Foot pressure: 2-3

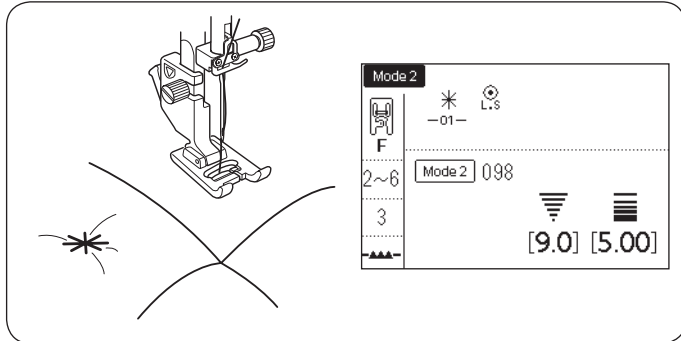

You can close quilt layers and using the clasp stitch.
 Select stitch 098 in mode 2.
 Press the memory key.
 Select stitch 202 in mode 2 (L.S ).
 Press the memory key.
 Start sewing.
 The machine sews clasp stitch and locking stitch then stops automatically.

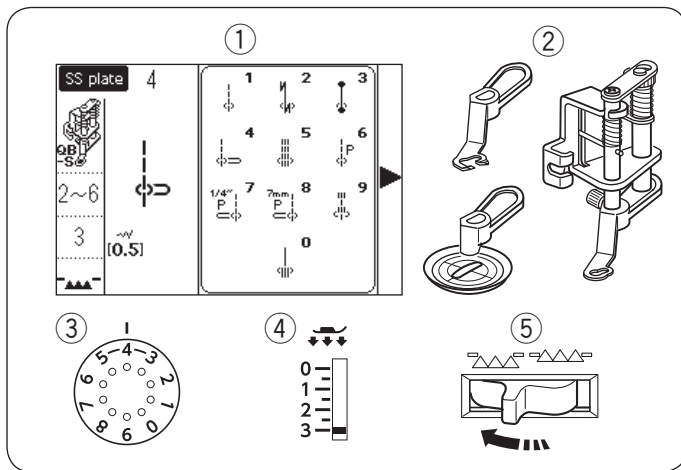

Free Motion Quilting (1)

- ① Pattern: SS plate: 4*
- ② Presser foot: Convertible free motion quilting foot QB-S
- ③ Thread tension: 2-6
- ④ Foot pressure: 3
- ⑤ Feed dog: Lowered

* Select pattern 1 when using clear view foot.

CAUTION:

Do not move the quilt layers toward you when the open-toe foot is attached.

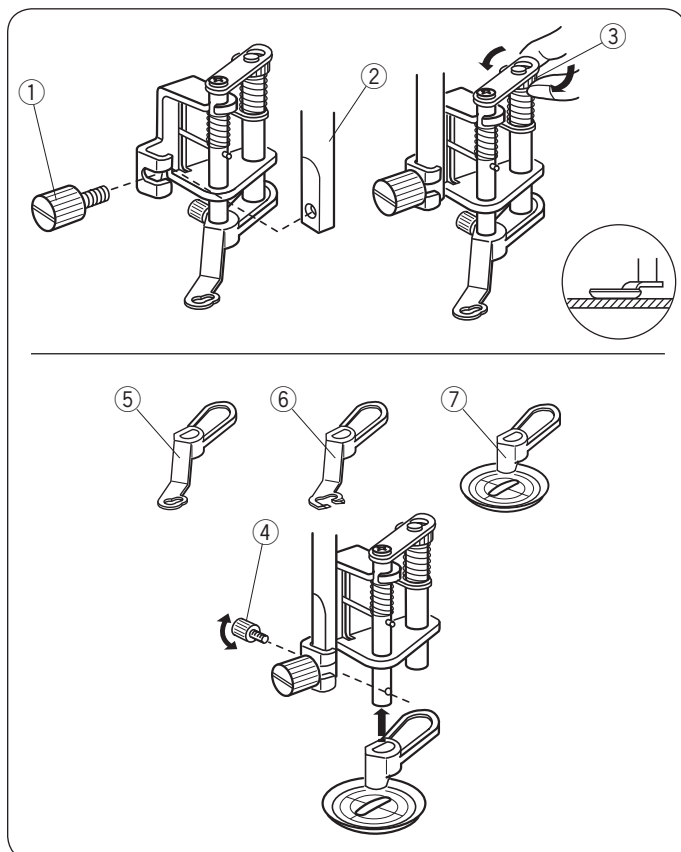

Attaching the convertible free motion quilting foot

Attach the needle plate for straight stitch (refer to page 26).
 Loosen the setscrew and remove the foot holder.

Attach the convertible free motion quilting foot to the presser bar and tighten the setscrew firmly with the screwdriver.

Place the fabric under the foot.

Adjust the height of the foot by turning the round nut until bottom of the foot barely touches top of the fabric.

- ① Setscrew
- ② Presser bar
- ③ Round nut

Changing the foot

This foot comes with the closed-toe foot attached, however, it is convertible to the open-toe foot and clear view foot.

To change the foot, raise the foot and turn the round nut to bring the foot to the lowest position.

Remove the setscrew and remove the closed-toe foot.

Attach the desired foot and secure it with the setscrew. Adjust the height of the foot (see above).

- ④ Setscrew
- ⑤ Closed-toe foot
- ⑥ Open-toe foot
- ⑦ Clear view foot

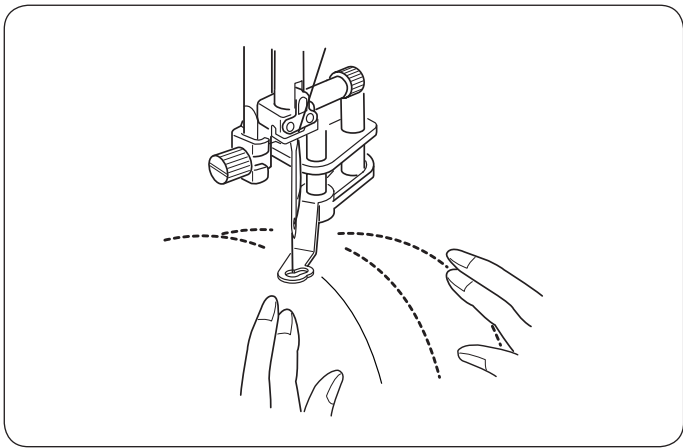

Sewing

Baste or pin the quilt layers. Draw a quilt design on the top fabric with a washable maker.

Sew at medium speed while guiding the quilt layers with your hands.

Move the quilt layers 3 mm (1/8") or less per stitch.

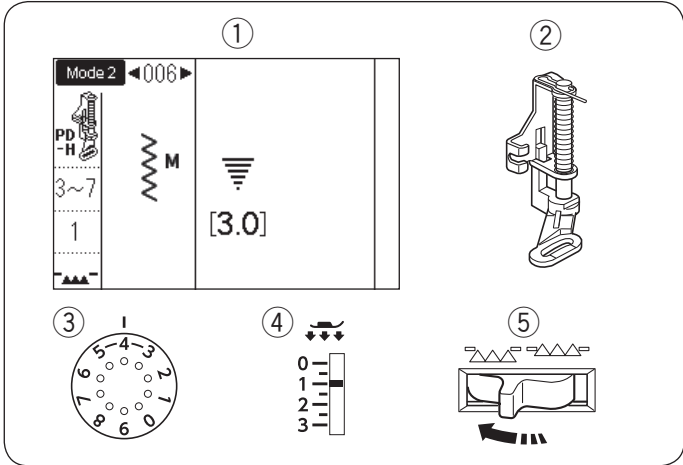

Free Motion Quilting (2)

- ① Pattern: MODE 2: 006
- ② Presser foot: Darning foot PD-H
- ③ Thread tension: 3-7
- ④ Foot pressure: 1
- ⑤ Feed dog: Lowered

The following stitch patterns can also be used for free motion quilting with Darning foot PD-H.

Mode 1	Mode 2
 ① ⑤ ⑥	 001 004 007 008 011

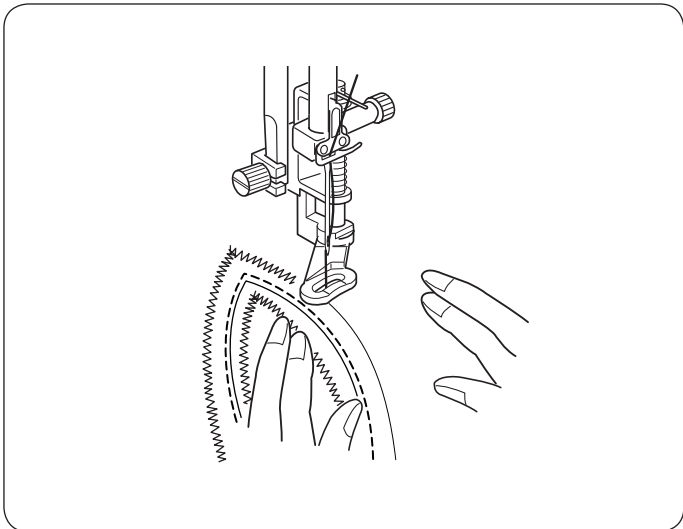

Free-quilting with darning foot PD-H

Stitch patterns 001, 004, 007, 008 and 011 in mode 2 can also be used for the free motion quilting. Use the darning foot PD-H when sewing those patterns.

NOTE:

A message appears when starting the machine with the feed dog lowered.

Start sewing again to proceed sewing.

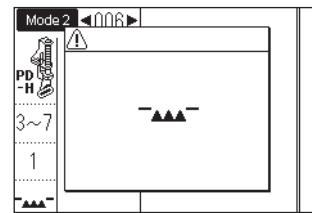

The sewing procedure is the same as the free motion quilting (1) (refer to page 77).

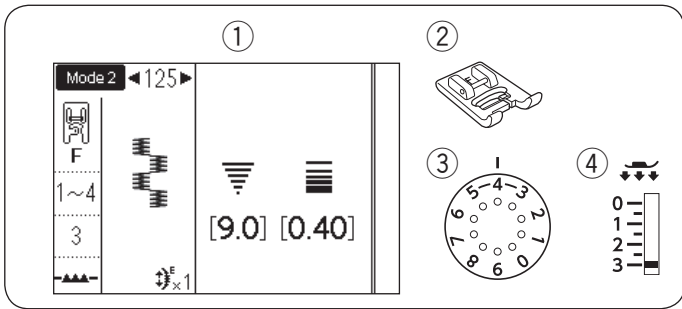

Satin Stitches

- ① Pattern: MODE 2: 125
- ② Presser foot: Satin stitch foot F
- ③ Thread tension: 1-4
- ④ Foot pressure: 3

The following stitch patterns can also be used for satin stitches.

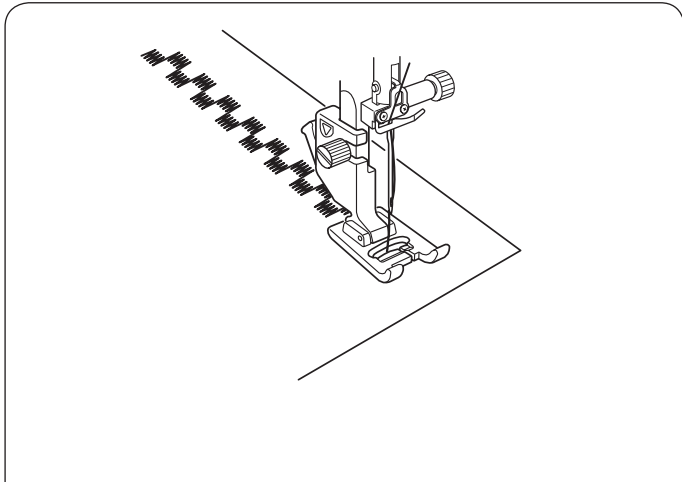
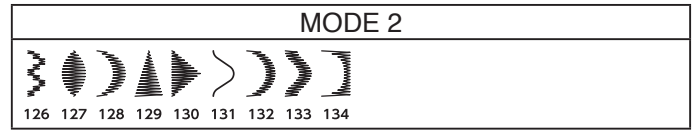

The stitches in this group can be elongated up to 5 times their original length while the stitch density remains the same.

Elongation ratio

Example: Pattern number 127

Select pattern number 127 in mode 2.

Press the elongation key to select the desired elongation ratio.

Elongation ratio is indicated in multiples of the original pattern length; X1 (original length) to X5.

- ① Elongation key
- ② Elongation ratio

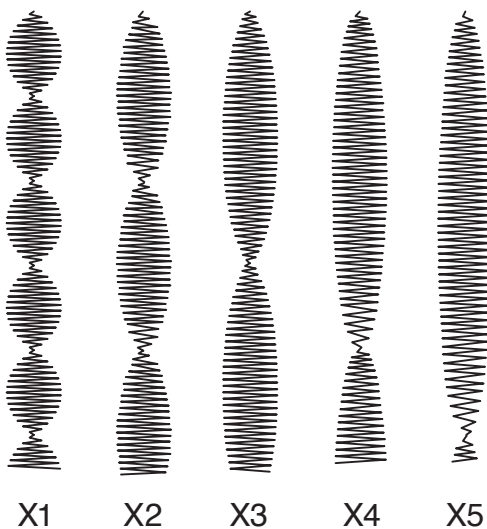
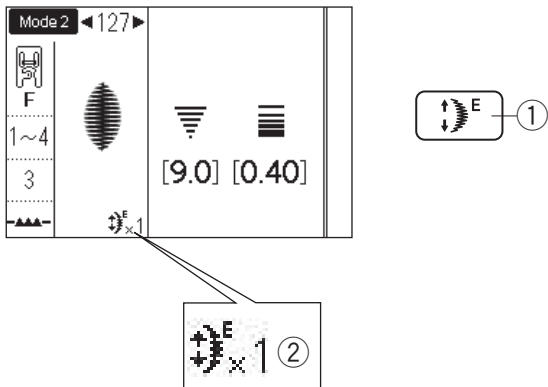

The stitch length and width can also be changed.

Twin Needle Sewing Preparation

Replace the needle with the twin needle supplied with the standard accessories.

CAUTION:

Turn the power switch off or press the lockout key before changing the needle.

Do not use twin needles other than one included in the standard accessories, otherwise the needle may hit the needle plate, foot or hook and break.

① Lockout key

Place two spools of thread on the spool stand.

To thread the left spool thread, draw the thread from the left spool and pass them through the threading points from ① and ③ to ⑥.

Slip the thread through the slit of the lower thread guide ⑦, (behind the lower needle guide hole) then pass through points ⑨ and ⑪ as illustrated.

To thread the right spool thread, draw the thread from the right spool and pass them through the threading points from ① to ⑥.

Draw the thread through the hole of the lower thread guide ⑧, then pass the thread to the point ⑩ as illustrated.

Make sure that the two strands of thread from the spools do not get tangled.

NOTE:

- Threading from points ③ to ⑥ is the same as for a single needle (refer to page 22-23).
- The needle threader cannot be used with the twin needle.

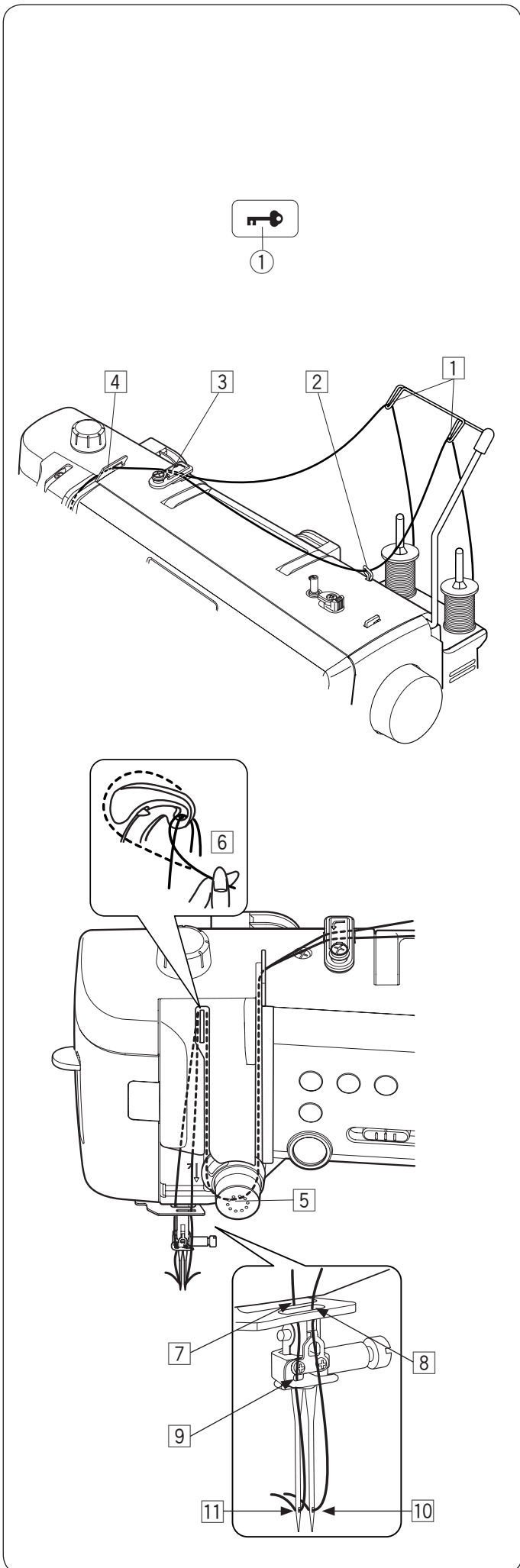

Stitch patterns for twin needle sewing (Mode 2)

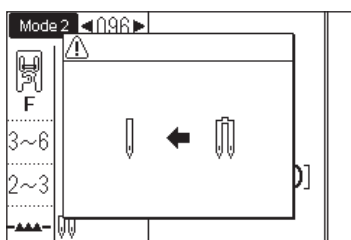
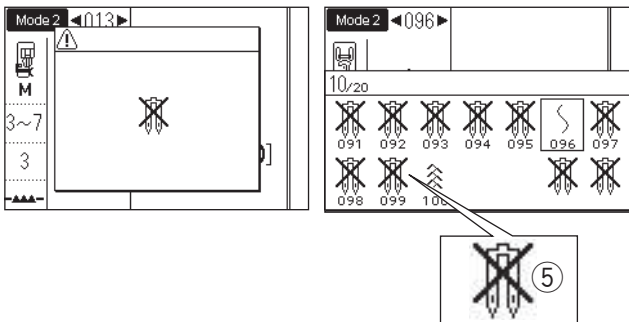
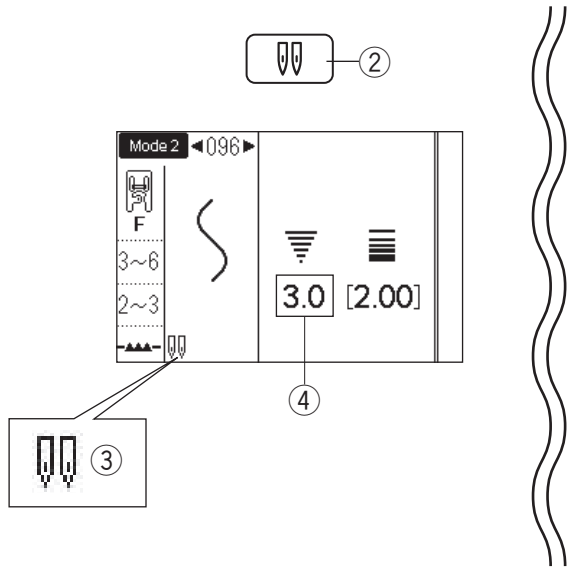
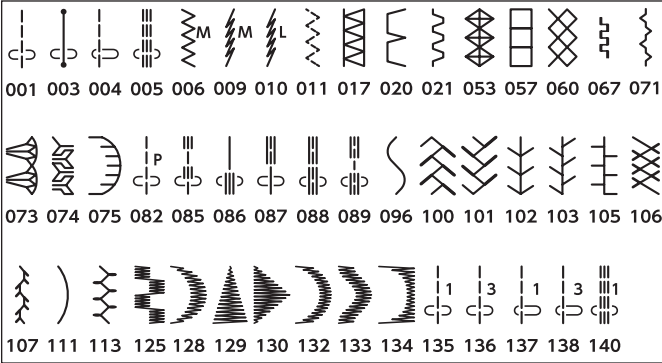

To sew

The stitches patterns in mode 2 shown on the left can be sewn with a twin needle.

Select the desired pattern suitable for twin needle sewing.

Press the twin needle key ②.

The LCD screen shows a twin needle mark ③ and the maximum permissible stitch width is restricted to 3.0 mm ④.

The needle drop position of straight stitches is restricted to between 3.0 and 6.0.

- ② Twin needle key
- ③ Twin needle mark
- ④ Maximum width (3.0)

When the twin needle mark is displayed, the pattern not suitable for the twin needle sewing will not be shown or cannot be selected (shown as the twin needle with the cross mark).

- ⑤ Patterns not suitable for twin needle sewing

NOTE:

- When you sew patterns with the twin needle, test the stitches first before you sew on the garment.
- Use the zigzag foot A or satin stitch foot F for twin needle sewing.
- Use the threads #60 or finer.
- When changing the sewing direction, raise the needle and presser foot then turn the fabric.
- Use the thread cutter on the face plate when cutting threads.

After twin needle sewing is finished, press the twin needle key and the warning message will appear. Replace the twin needle with a single needle. Press the twin needle key again to finish the twin needle sewing.

PROGRAMMING A PATTERN COMBINATION

Pattern Combination

Example: Programming patterns 190, 188 and 184 in mode 2.

NOTE:

- Patterns in the different groups, letters and numbers can also be programmed.
- The maximum number of the stitch pattern that can be registered in one pattern combination is 50.

1

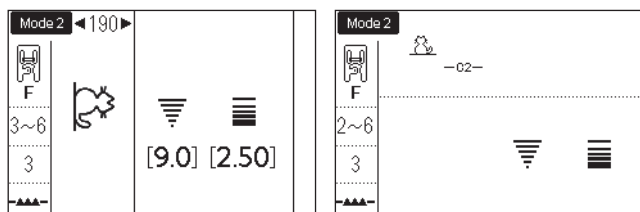

2

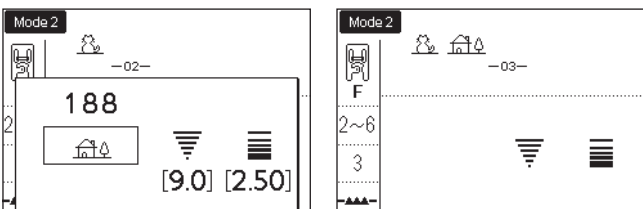

3

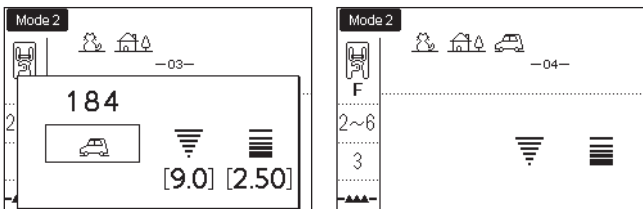

4

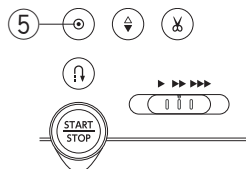
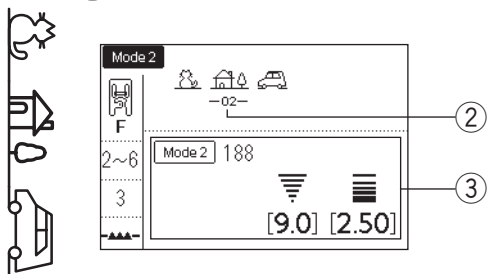

1 Select pattern 190 in mode 2 and press the memory key.

① Memory key

2 Select pattern 188 in mode 2 and press the memory key.

3 Select pattern 184 in mode 2 and press the memory key.

4 Start sewing.

Once sewing has started, the cursor ② appears under the first pattern and will shift to the right as you sew.

The information of the currently sewn pattern will be displayed on the LCD screen ③.

Combination of patterns 190, 188 and 184 will be sewn accordingly and repeatedly.

NOTE:

- You can start sewing from the middle of the pattern combination by using the startover key. After programming a pattern combination, select the stitch pattern that you want start from by pressing the startover key and start sewing.

④ Startover key

- If you press the auto-lock key in the middle of sewing, the machine will sew to the end of the current pattern, sew locking stitches and stop automatically.

⑤ Auto-lock key

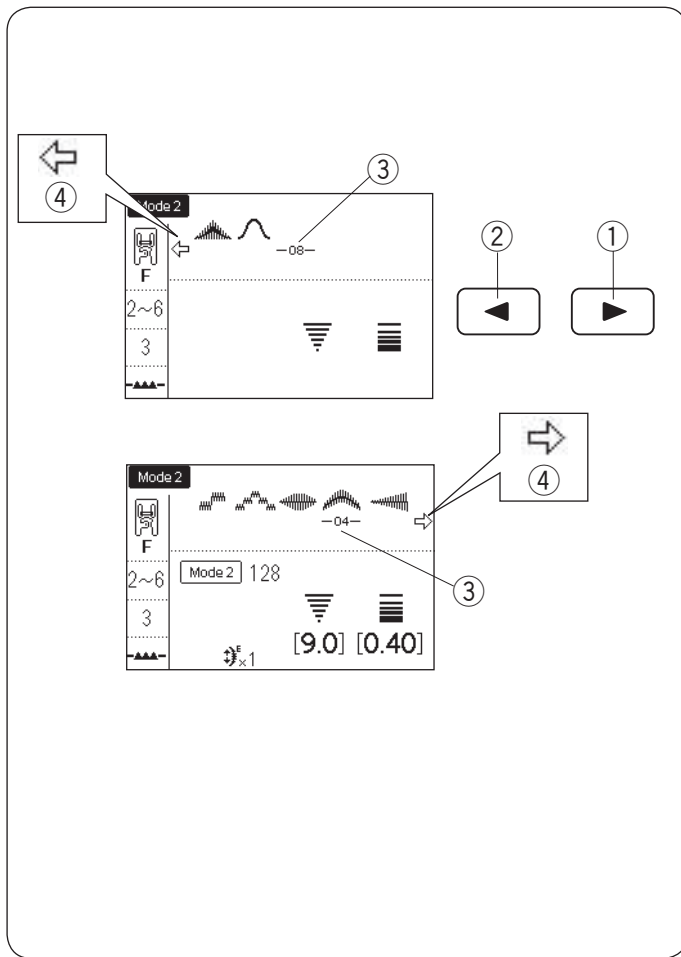

Editing a Pattern Combination

Viewing a long combination

If the pattern combination is too long and the entire pattern combination is not displayed, press the arrow key to view the rest of the combination.

Press the right arrow key “▶” ① to shift the cursor to the right.

Press the left arrow key “◀” ② to shift the cursor to the left.

NOTE:

Arrow marks (◀, ▶) ④ on the LCD screen indicate that there is the rest of the combination in that direction.

- ① Right arrow key
- ② Left arrow key
- ③ Cursor
- ④ Arrow mark

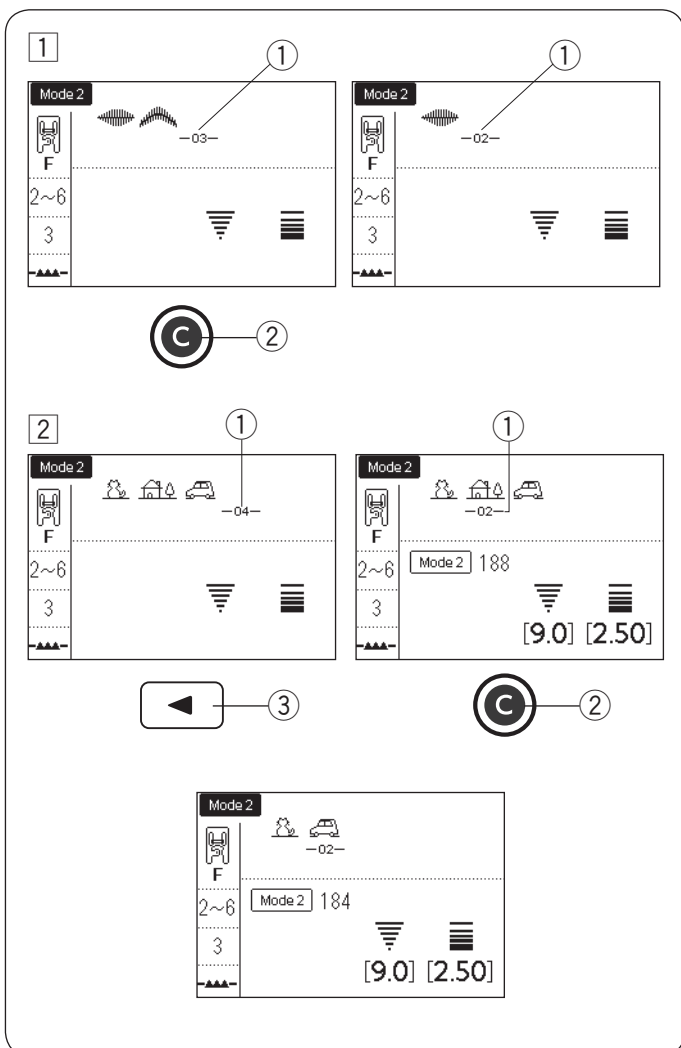

Deleting a Pattern

① The pattern before the cursor is deleted by pressing the clear key.

- ① Cursor
- ② Clear key

② To delete a pattern in the middle of a combination, press the arrow key to move the cursor under the pattern you want to delete.

Press the clear key to delete the selected pattern.

- ③ Arrow key

NOTE:

Pressing and holding the clear key will delete the entire pattern combination and the LCD screen will return to the initial screen of the selected mode.

Inserting a Pattern

- 1 Press the arrow keys to move the cursor where you want to insert a pattern.

- ① Cursor
- ② Arrow keys

- 2 Enter the desired pattern to insert. Press the memory key to insert the pattern.

- ③ Inserted pattern
- ④ Memory key

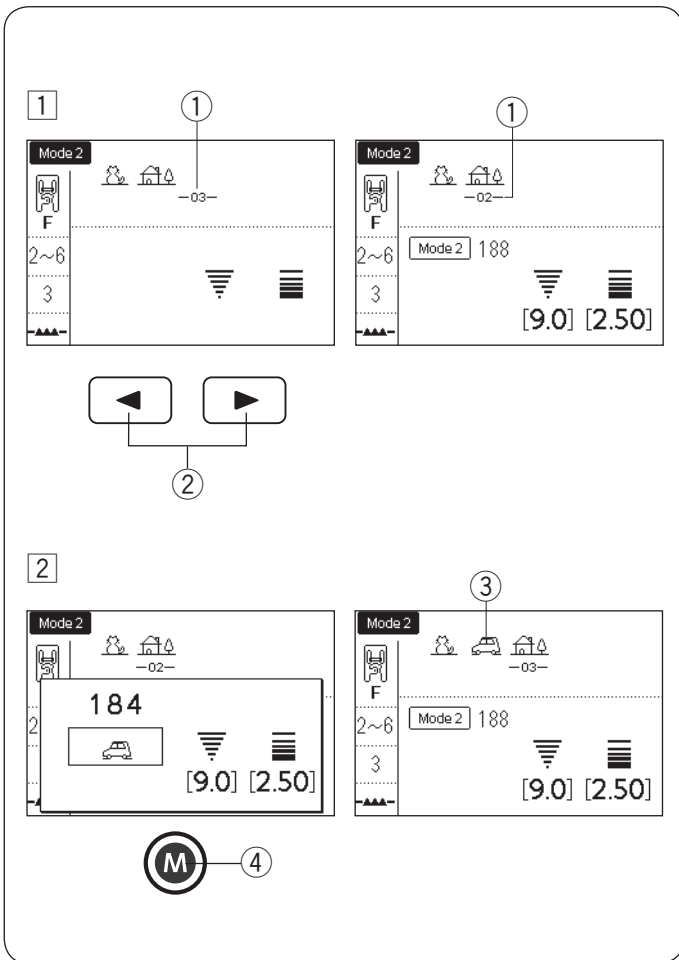

Duplicating a Pattern

- 1 Press the arrow key to move the cursor under the pattern you want to duplicate.

- ① Cursor
- ② Arrow key

- 2 Press the memory key to duplicate the selected pattern.

- ③ Memory key
- ④ Duplicated pattern

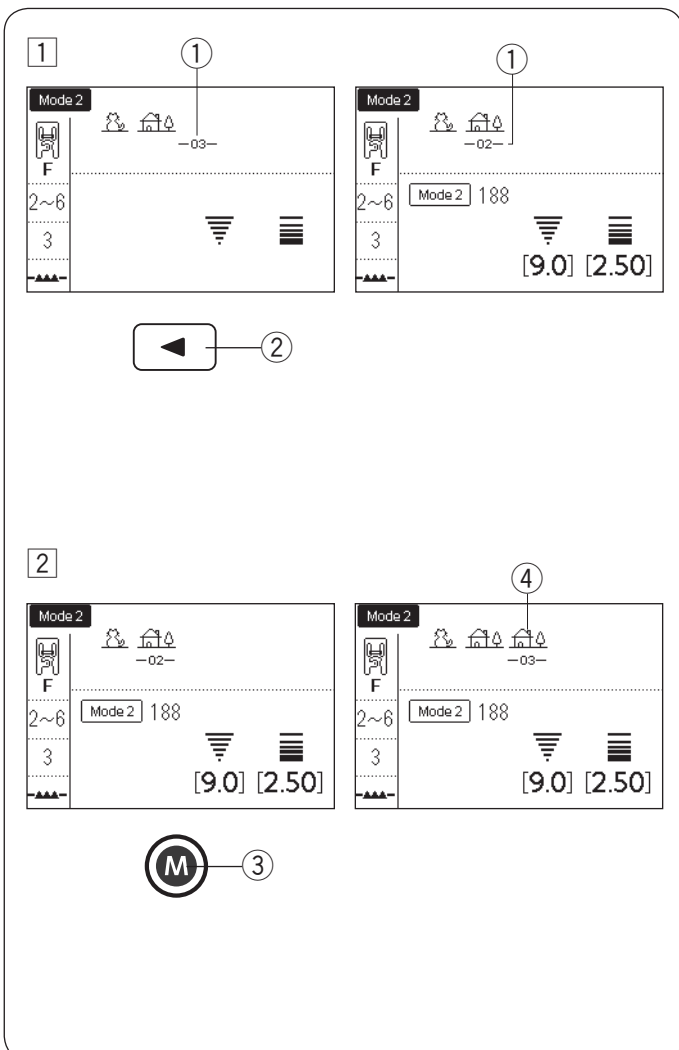

Programming Auto-lock Stitch

Example: Programming patterns 127 in mode 2 and auto-lock stitch.

The machine will sew the pattern, auto-lock stitch, and stop automatically.

1

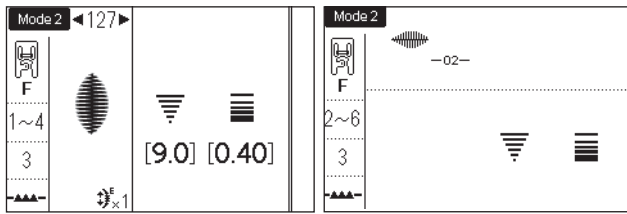

- 1 Select pattern 127 in mode 2.
Press the memory key.

① Memory key

2

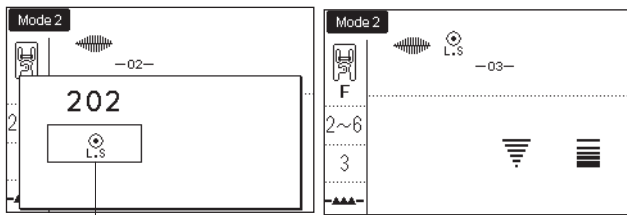

- 2 Select pattern "L.S" (202 in mode 2).
Press the memory key.

② Auto-lock sign

3

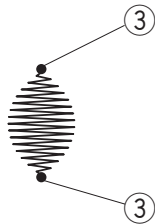

- 3 Start sewing. Pattern 127 and auto-lock stitch will be sewn automatically.
The auto-lock stitch will be sewn to the beginning and end of the stitch pattern.

③ Auto-lock stitch

Automatic Thread Cutting

To cut the threads automatically after sewing the pattern combination, turn on the auto thread cutting function (refer to page 34, "Auto thread cutting" section).

The cutter mark ④ will appear on the LCD screen.

Start sewing.

The machine will sew the pattern combination, auto-lock stitch and cut the threads, then stop automatically.

④ Cutter mark

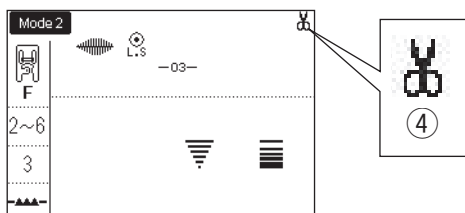

Mirror Image

Example: Pattern 184 in mode 2 and its mirror image

① Select pattern 184 in mode 2.

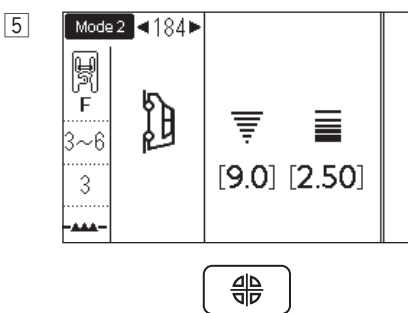
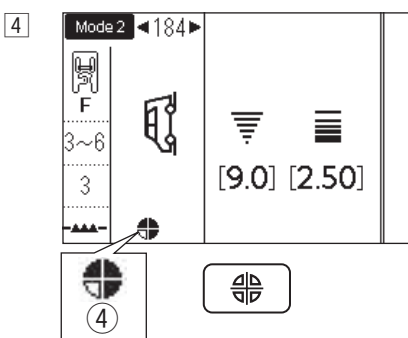
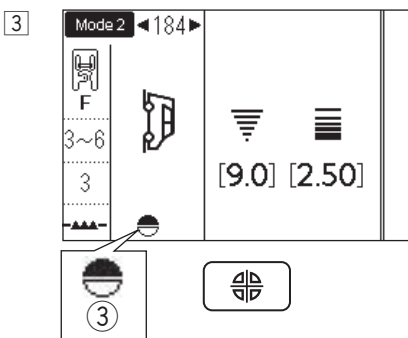
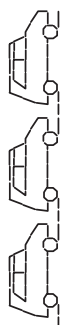
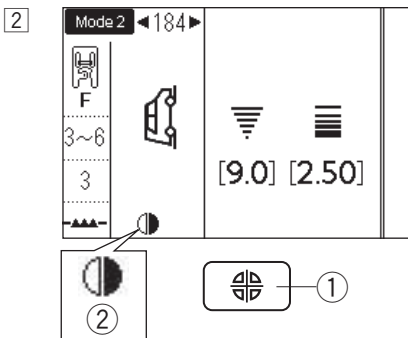
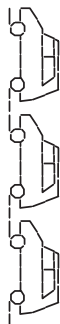
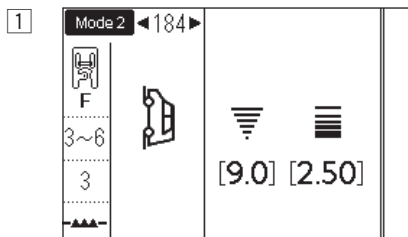

② Press the mirror image key to flip the pattern on a vertical line. The vertical mirror sign is displayed.

- ① Mirror image key
- ② Vertical mirror sign

③ Press the mirror image key again to flip the pattern on a horizontal line. The horizontal mirror sign is displayed. The stitch pattern will be back to normal if the pattern cannot be flipped horizontally.

- ③ Horizontal mirror sign

④ Press the mirror image key again to flip the pattern vertically and horizontally. The mirror image (vertical and horizontal) sign is displayed.

- ④ Mirror image sign (Vertical and horizontal)

⑤ Press the mirror image key again to back to the original orientation.

NOTE:

Horizontal mirror image is available only for the specific patterns. For pattern identification, these patterns are shaded in light grey on the reference chart.

Mirror image function will be canceled and mirror image icon will disappear if the selected pattern is not suitable for the mirror image.

Pattern Combination with a Mirror Image

Example: Pattern 128 in mode 2 and its mirror image

1

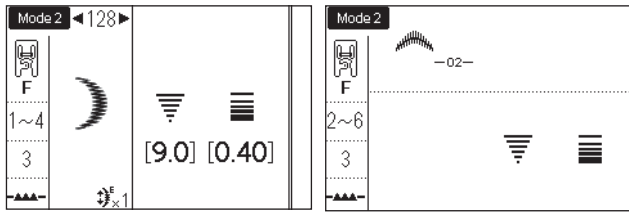

2

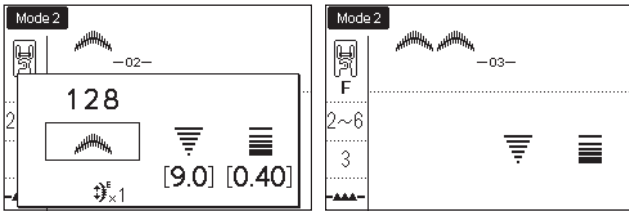

3

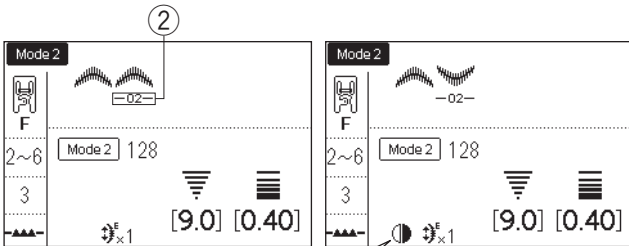

4



- 1 Select pattern 128 in mode 2.
Press the memory key.

① Memory key

- 2 Select pattern 128 again.
Press the memory key.

- 3 Press the left arrow key “◀” to move the cursor ② under the pattern you want to turn over.

Press the mirror image key.

The pattern will be flipped and the vertical mirror sign appears.

- ② Cursor
- ③ Left arrow key
- ④ Vertical mirror sign
- ⑤ Mirror image key

- 4 Start the machine.
The machine will sew the pattern combination repeatedly.

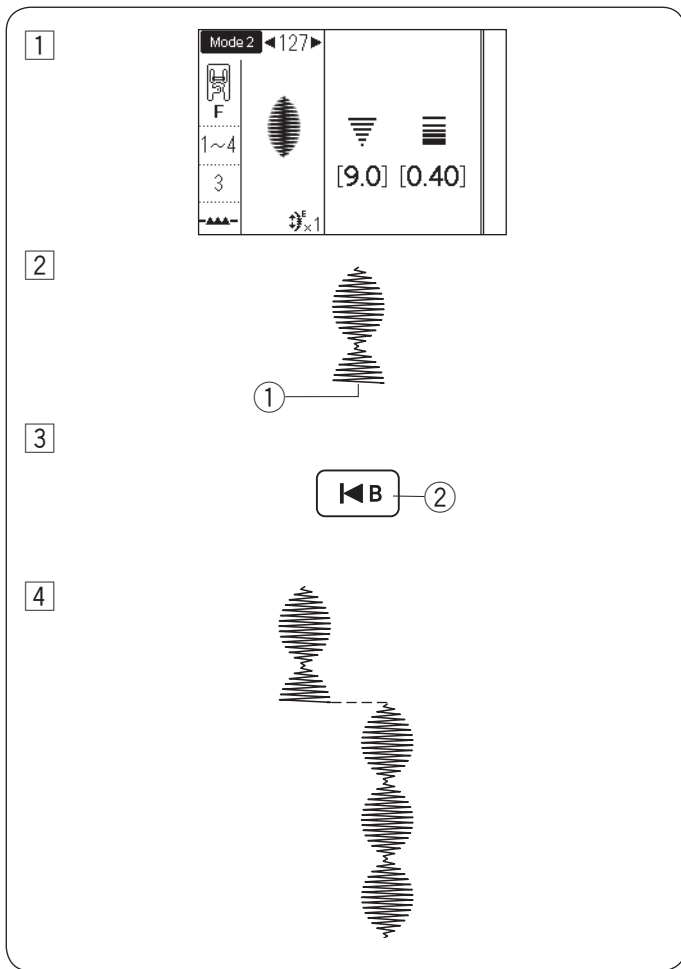

Sewing the Pattern from the Beginning

If you have to stop sewing in the middle of a pattern and want to sew it over again, press the startover key to sew the pattern from the beginning.

Example: Pattern 127 in mode 2

- 1 Select pattern 127 in mode 2. Start sewing.
- 2 Sewing stopped.
 - ① Stopped position
- 3 Press the startover key.
 - ② Startover key
- 4 Start sewing again.
Sewing starts over from the beginning of the pattern.

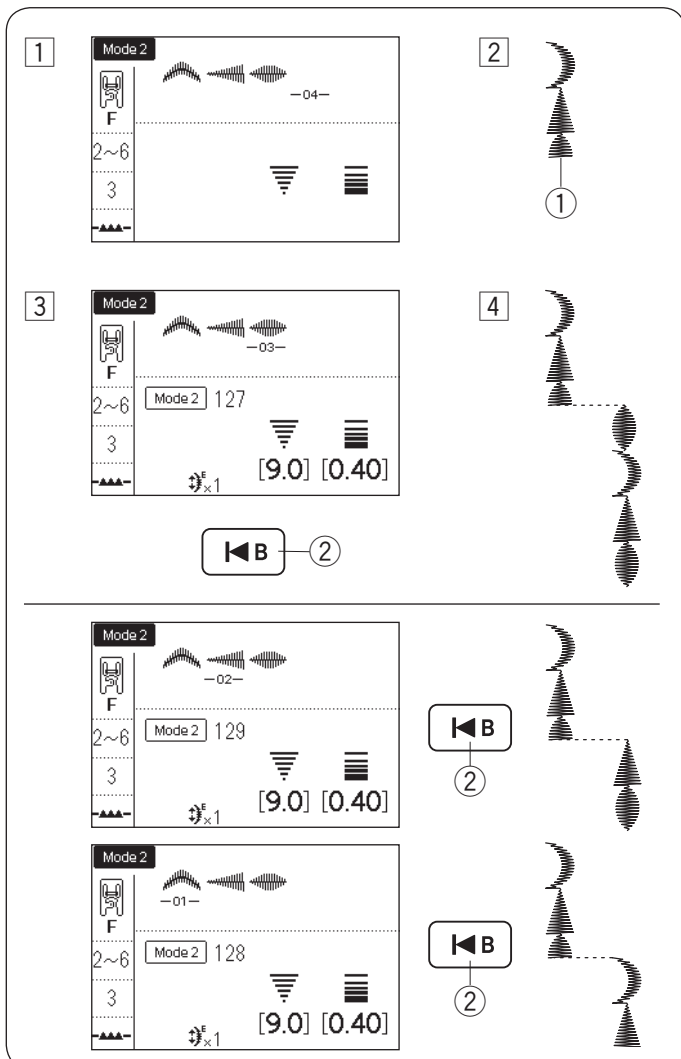

Sewing the Pattern Combination from the Beginning

Example: Pattern combination 128, 129 and 127 in mode 2

- 1 Program the pattern combination 128, 129 and 127 in mode 2. Start sewing.
- 2 Sewing stopped.
 - ① Stopped position
- 3 Press the startover key.
 - ② Startover key
- 4 Sewing starts over from the pattern with the cursor.

NOTE:

If you press the startover key again, the cursor will move forward one by one. Move the cursor you want to start over from.

Bridge Stitches

The following stitch patterns are bridge stitches, which are used to insert straight stitches after a stitch pattern.

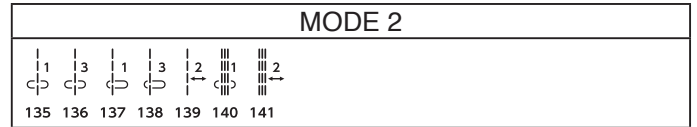
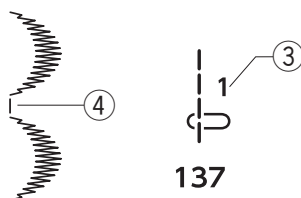
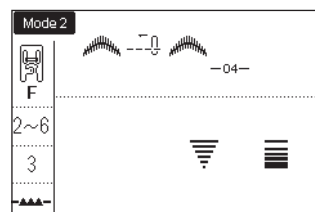
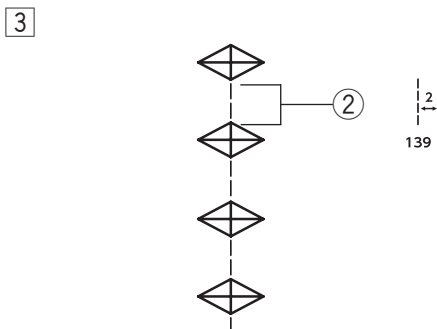
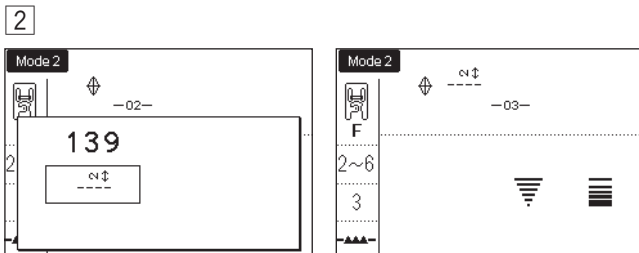
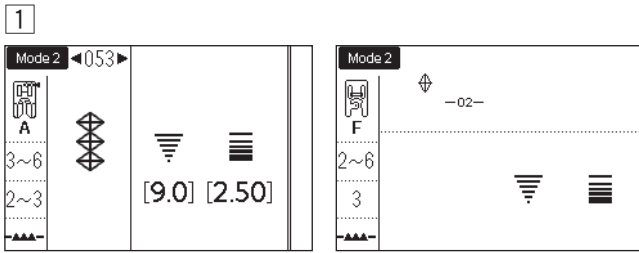

Example: Combination of pattern 053 and pattern 139 in mode 2

- 1 Select pattern 053 in mode 2.
Press the memory key.
① Memory key
- 2 Select pattern 139 in mode 2.
Press the memory key.
- 3 Two counts of the straight stitch are added to pattern 053.
② Bridge stitch

NOTE:

- The number ③ on the right of the stitch image indicates stitch counts to be inserted.
- The stitch length and needle drop position of following bridge stitches are independent from those of the combined pattern.

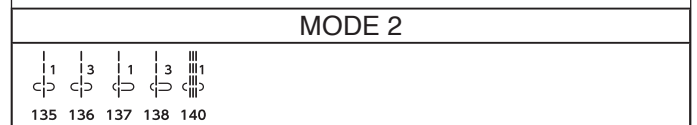

The following bridge stitches will inherit the stitch length and needle drop position of a previous pattern in the programmed pattern combination.

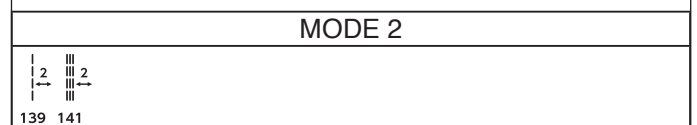

Use patterns 135-138 with satin stitches.

- ④ Pattern 137

Use pattern 140 if you want to add straight stretch stitches.

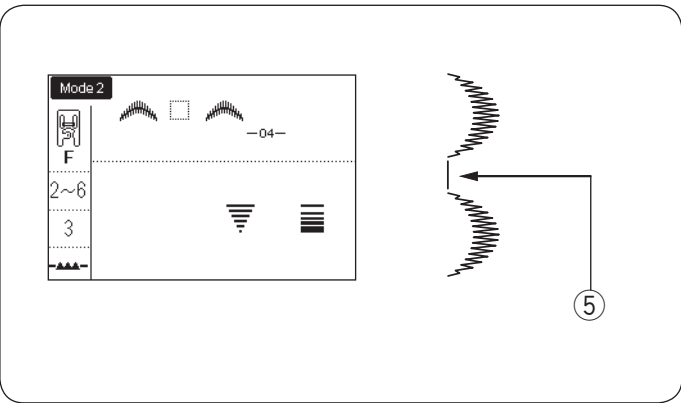

Use a blank space if you want to insert a space between stitch patterns (Mode 2: pattern 201).

- ⑤ Blank space

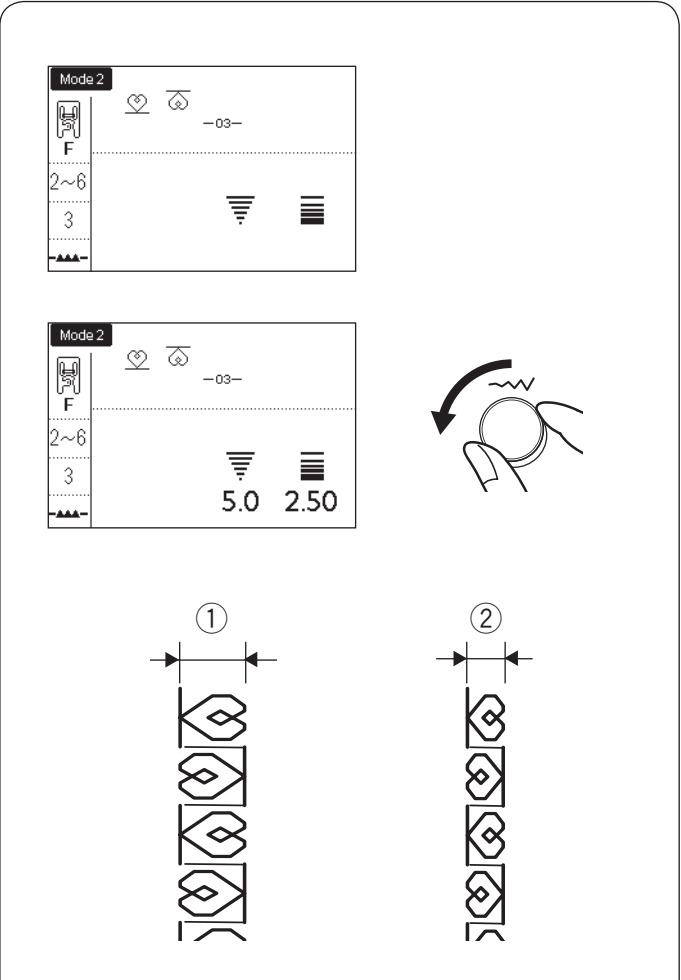

Uniform Stitch Adjustment

The stitch width and length of the programmed patterns can be uniformly adjusted.

Example 1: Adjusting the stitch width of the programmed pattern 151 in mode 2 and its mirror image

Shift the cursor to the right of the last programmed pattern.

Turn the stitch width adjusting dial to adjust the stitch width.

NOTE:

Stitch length can be uniformly adjusted if the programmed patterns in the same category (satin stitches or stretch stitches, etc.) have been programmed.

The stitch width of the programmed patterns will be adjusted uniformly.

- ① Original width
- ② Uniformly adjusted width

Needle drop position of programmed patterns

The needle drop position of the programmed patterns will vary depending on the pattern combination:

- (A) Unified to the left when combining the patterns with the left needle position and the center needle position.
- (B) Unified to the right when combining the patterns with the center needle position and the right needle position.
- (C) Unified to the center when combining the patterns with the left needle position and the right needle position.
- (D) Unified to the center when combining the patterns with the left, center and right needle positions.

Individual Stitch Adjustment

The stitch width and length can be individually adjusted for each pattern in a programmed combination.

Example: Changing the stitch width of the one pattern in the combination

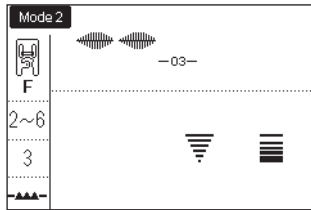

1

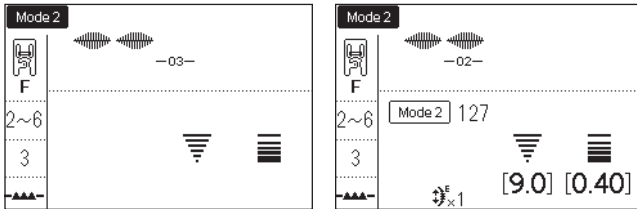

1 Press the arrow key to shift the cursor under the pattern you want to adjust.

① Left arrow key

2

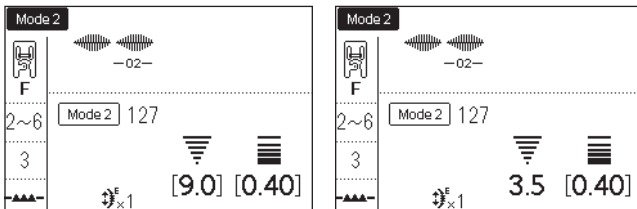

2 Turn the stitch width adjusting dial to adjust the width to "3.5".



NOTE:

To view the stitch settings of each pattern, shift the cursor under the desired pattern.

The settings will be displayed at the bottom of the LCD screen.

If you turn the stitch width or length adjusting dial when the cursor is to the right of the last programmed pattern, individual adjustments will be cancelled and uniform adjustment will be applied.

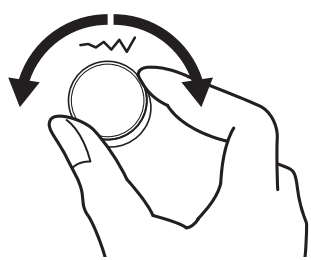
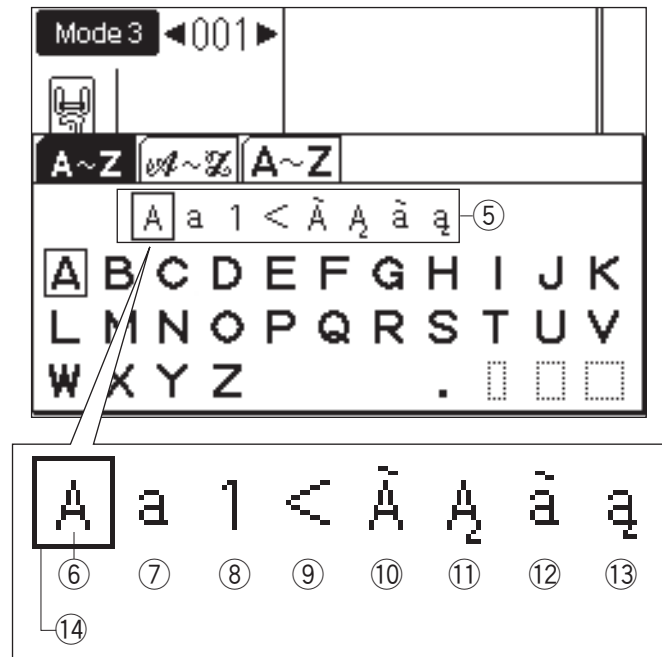
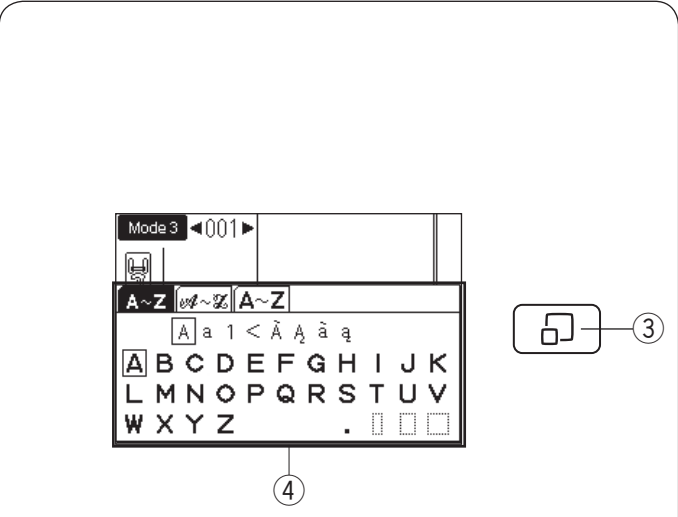
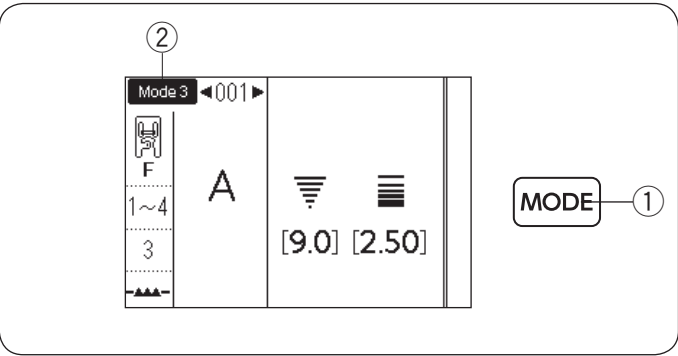

MONOGRAMMING

In mode 3, you can program text by entering the number and alphabets.
Press the mode key to enter mode 3 ② (Monogramming mode).

① Mode key

Entering Monogram Letters with Jog Dials

You can enter the monogram letters by entering the pattern number of the desired monogram, or pressing arrow keys. However, it is very convenient to use the monogram selection window when entering letters for monogram.

Press the stitch display key and the monogram selection window ④ appears.

You can select the desired character with the jog dials from the selection.

③ Stitch display key

④ Monogram selection window

• Selecting a character style

Turn the stitch width adjusting dial clockwise or counterclockwise with the monogram selection window displayed.

The cursor for character style selection moves and the character style changes as you turn the dial.

Select the desired character style from the selection.

⑤ Character style selection

⑥ Upper case alphabet

⑦ Lower case alphabet

⑧ Numbers and Symbols

⑨ Symbols

⑩ Upper case European letters 1

⑪ Upper case European letters 2

⑫ Lower case European letters 1

⑬ Lower case European letters 2

⑭ Cursor (character style selection)

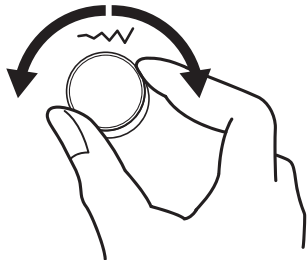
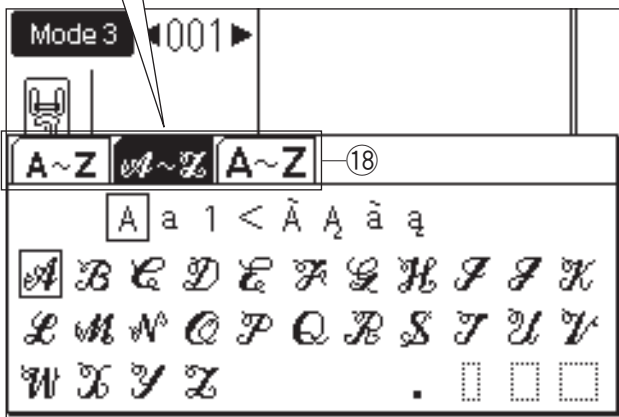
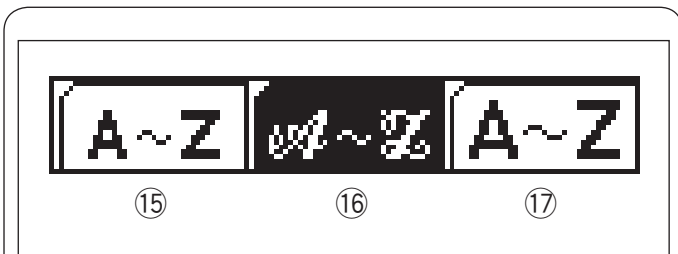

1 2

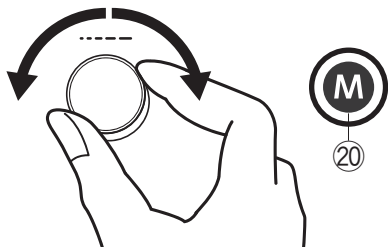
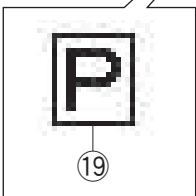
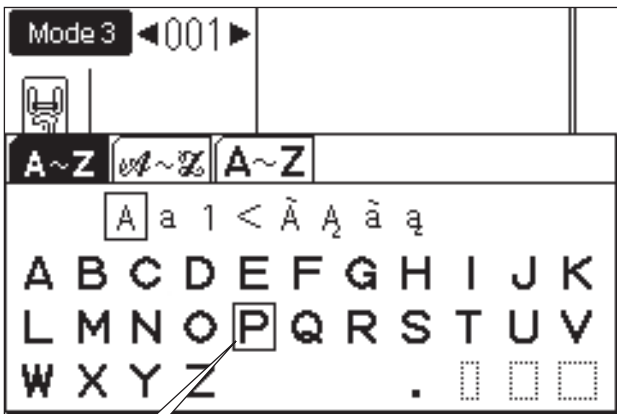

3

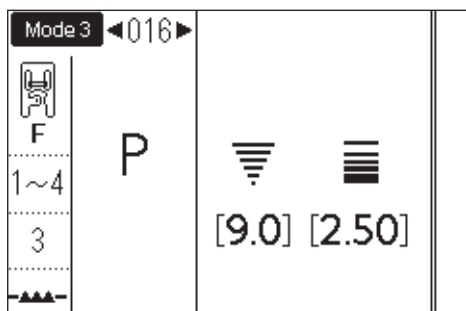

• Selecting a font style

Turn the stitch width adjusting dial and move the cursor out of the character style selection to change the font style. The tab of selected font style will be inverted as shown in ⑮.

The following 3 styles are available.

- ⑮ Block
- ⑯ Script
- ⑰ 9 mm monogram
- ⑱ Font style selection (tabs)

NOTE:

Cyrillic letters and Japanese letters are available when selecting Russian or Japanese language (refer to page 35, "Language selection"). The extra font style tab appears when those language are selected.



Cyrillic

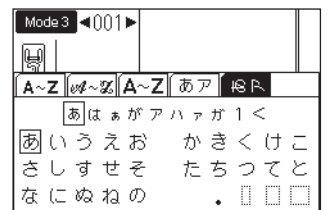

Japanese

• Selecting a letter (character)

① Turn the stitch length adjusting dial clockwise or counterclockwise to move the cursor for selecting letter.

② After selecting the desired letter with the cursor, press the memory key.

- ⑲ Cursor (letter selection)
- ⑳ Memory key

③ The selected letter will be displayed as shown.

Programming a Monogram

Example: To program “R&B”

- 1 Press the mode key to enter mode 3.
Press the stitch display key.
 - ① Mode key
 - ② Stitch display key
- 2 Turn the stitch length adjusting dial to select the letter “R”. Press the memory key.
 - ③ Memory key
- 3 Press the memory key again.
The letter “R” has been registered.
- 4 Press the stitch display key.
Turn the stitch width adjusting dial and stitch length adjusting dial to select the letter “&”.
Press the memory key.
- 5 The letter “&” has been registered.
Turn the stitch width adjusting dial and stitch length adjusting dial to select the letter “B”.
Press the memory key.
- 6 The letter “B” has been registered.
Start sewing.
The machine will sew “R&B” and stop automatically.

NOTE:
Turn the auto thread cutter function on (refer to page 34, “Auto thread cutting” section.) to cut the thread automatically after the sewing.

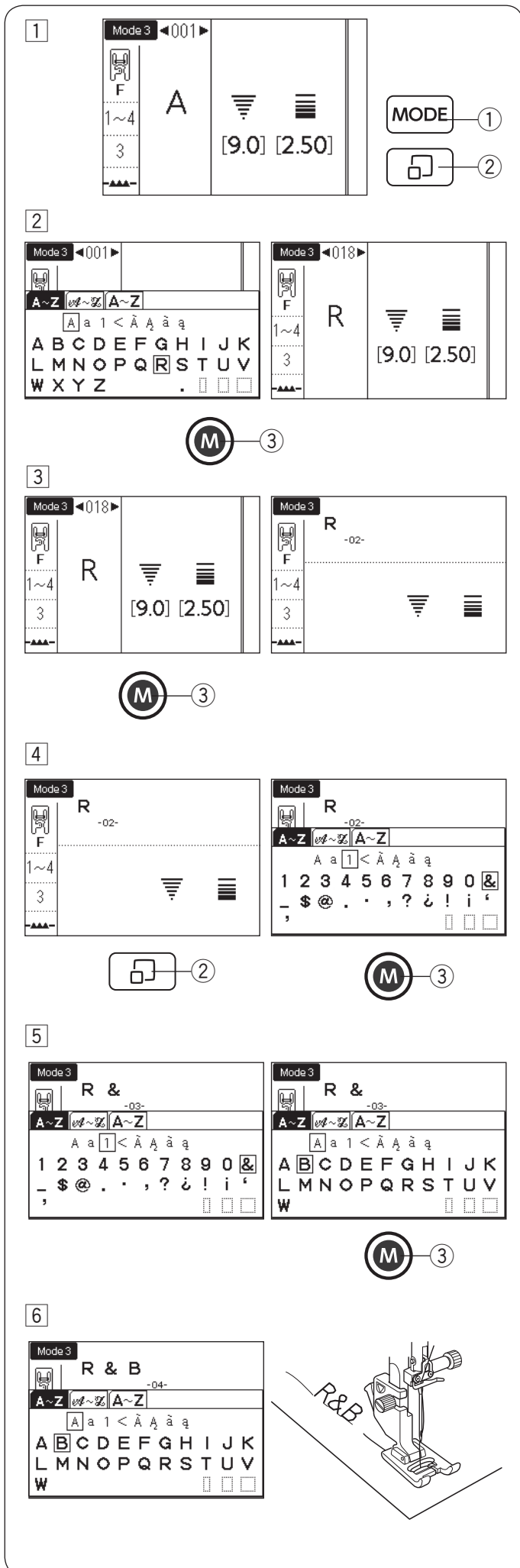

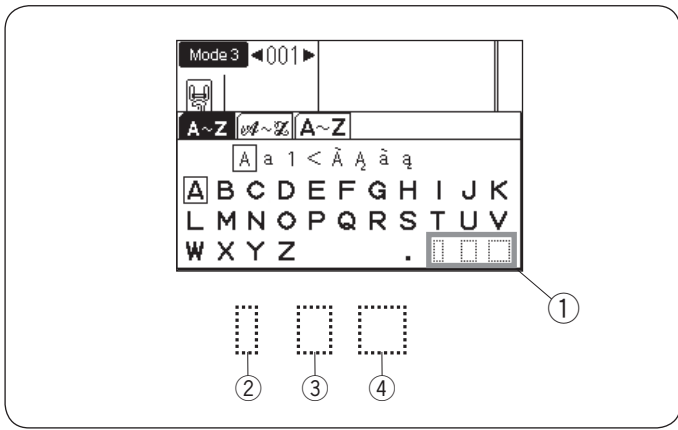

Spacing

To enter the space in monogramming, select one of the three space icons on the lower right corner of the monogram selection window.

- ① Space icons
- ② Small-size space
- ③ Medium-size space
- ④ Large-size space

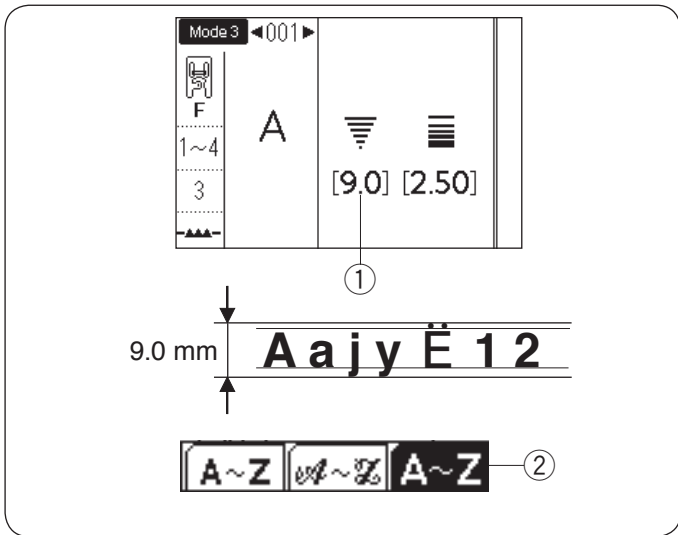

Monogram size

When the stitch width is set at “9.0” ①, the actual sewing result of monogramming size will be slightly smaller than 9 mm.

To sew monogramming of full 9 mm height (uppercase alphabet only), select 9 mm monogram from the font style ② (refer to page 93).

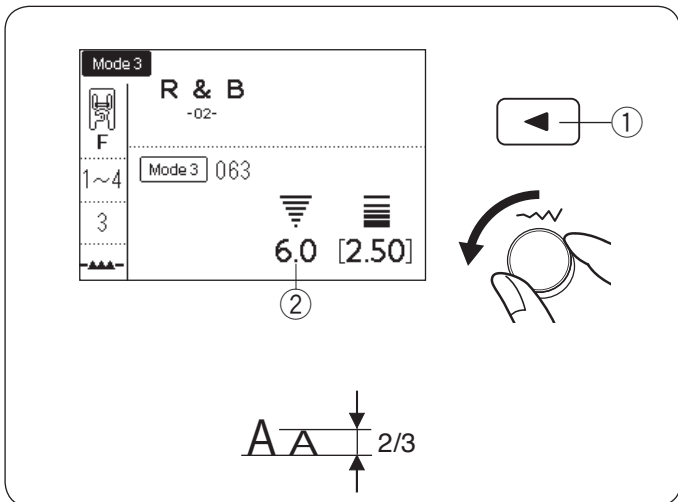

Reducing the size of letters

To reduce the height of character to approximately 2/3 of its original size, select the character with the arrow key and turn the stitch width adjusting dial counterclockwise.

The stitch width (the height of character) is set at “6.0” ②.

- ① Arrow key

NOTE:

The size of 9 mm monogram cannot be reduced.

STORING AND RECALLING A PATTERN COMBINATION

Up to 20 pattern combinations can be stored in the memory for future use even after turning the power off. The stored pattern combination can be recalled by pressing the folder/FS key.

Storing a Pattern Combination

- 1 Program a pattern combination.
Press the folder/FS key.
 - 1 Folder/FS key

- 2 The memory recall window appears.

- 3 You can select the address where you want store the pattern combination.
Turn the stitch width adjusting dial to turn the address pages.
Turn the stitch length adjusting dial to move the cursor to select the address.
The memory address is displayed on the upper left corner of the LCD screen.
 - 2 Memory address
 - 3 Cursor

- 4 Press the numeral key “1”.
The pattern combination will be stored to the selected memory address.
 - 4 Stored pattern combination

NOTE:

If a pattern combination has been already stored to the address, the stored combination will be replaced with the new one.

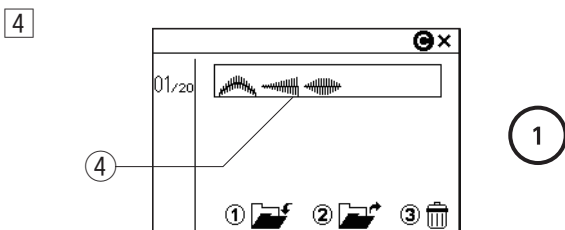
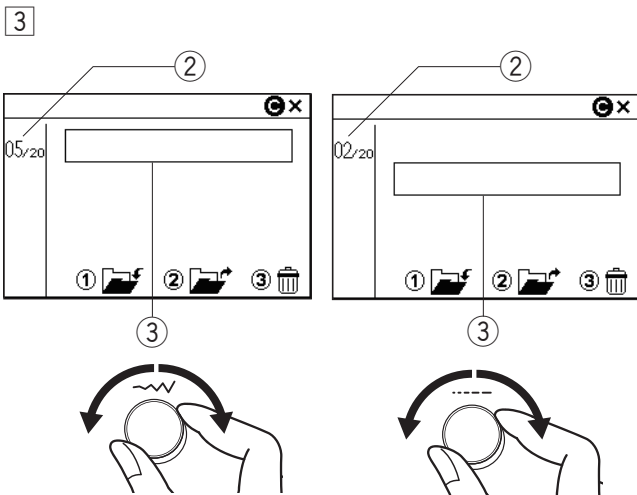
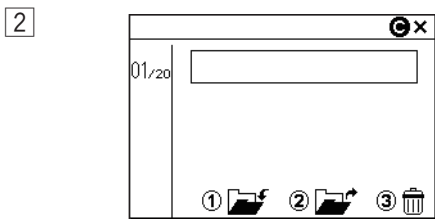
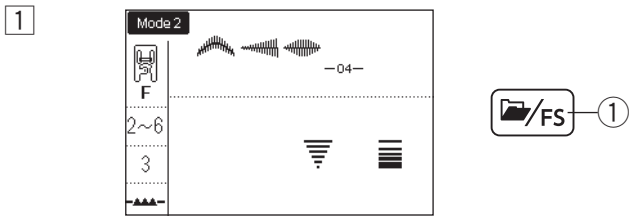

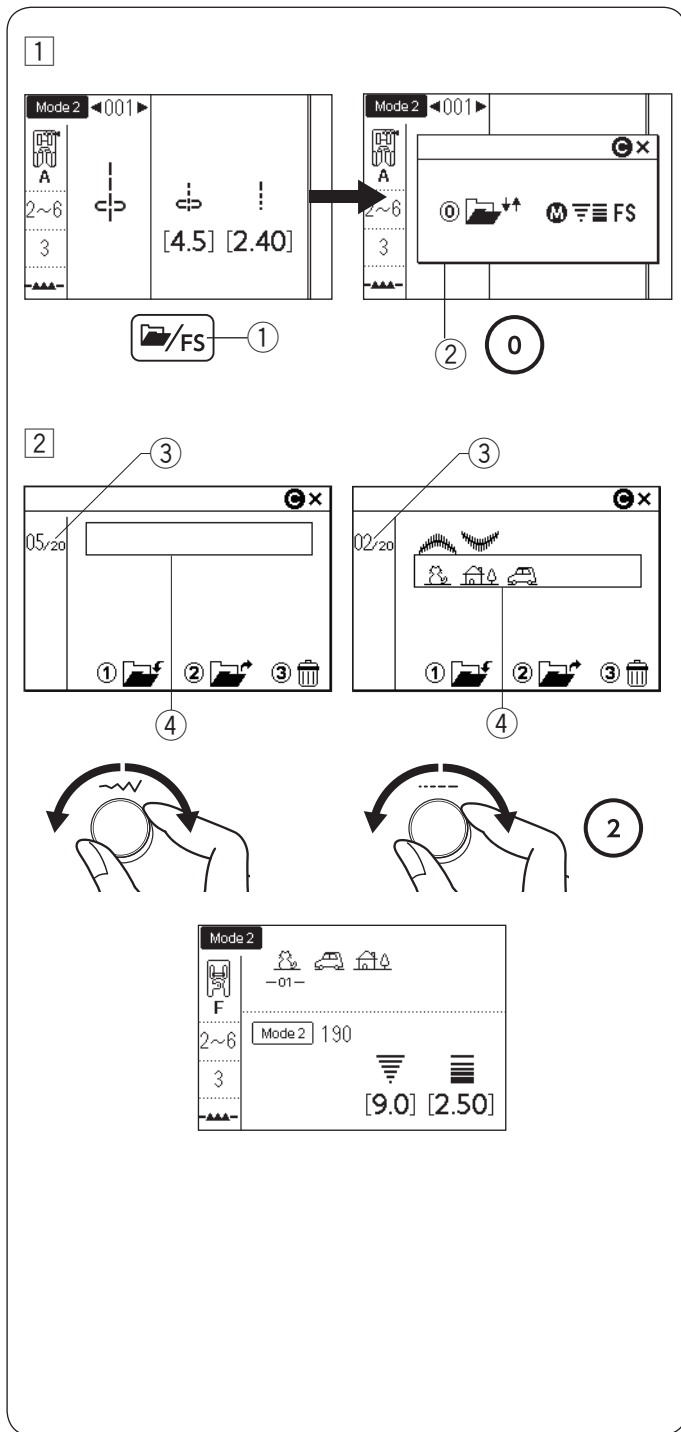

Recalling a Stored Combination

- 1 Press the folder/FS key.
The selection window appears when a single pattern is displayed on the LCD screen.
Press the numeral key “0” to display the memory recall window.
 - ① Folder/FS key
 - ② Selection window
- 2 Turn the jog dials to select the memory address where the desired pattern combination is stored.
Turn the stitch width adjusting dial to turn the address pages.
Turn the stitch length adjusting dial to move the cursor to select the address.
Press the numeral key “2” to recall the stored combination.
 - ③ Address page
 - ④ Cursor

NOTE:

If the favorite stitch function is turned off, or a stitch pattern combination is displayed on the LCD screen, the memory recall window will be displayed when the folder/FS key is pressed (refer to page 35).

NOTE:

The stored combination cannot be recalled if the straight stitch needle plate or professional grade needle plate is attached, or the twin needle mark is displayed on the LCD screen (refer to page 81).

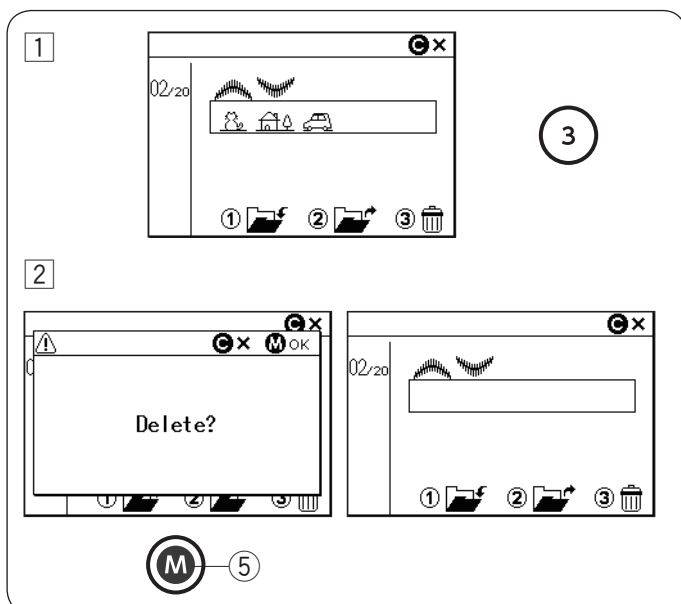

Deleting a Stored Combination

- 1 Select the memory address storing the pattern combination you want to delete by turning the jog dials.
Press the numeral key “3”.
- 2 The confirmation message appears.
Press the memory key to delete the stored combination.
 - ⑤ Memory key

NOTE:

To close the memory recall window, press the clear key.

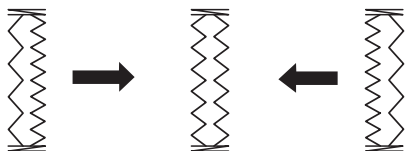
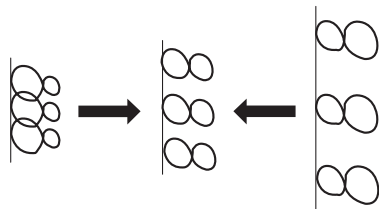
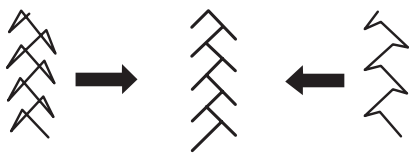
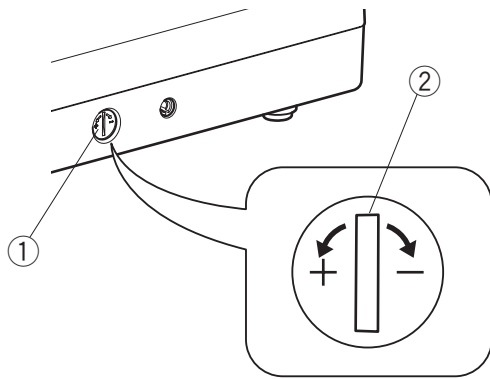

Correcting Distorted Stitch Patterns

The sewing results of the stitch patterns may vary depending upon sewing conditions, such as sewing speed, type of the fabric, number of layers etc.

Always test sew on a scrap piece of the fabric that you wish to use.

If stretch stitch patterns, monogram or the stretch buttonhole is distorted, correct it with the feed balancing dial.

Set the feed balancing dial at the neutral position for normal sewing.

- ① Feed balancing dial
- ② Neutral position

NOTE:

Return the feed balancing dial to its neutral position when the sewing is finished.

Stretch stitch pattern

Example: Pattern 100 (Mode 2)

If the pattern is compressed, turn the feed balancing dial in the direction of “+”.

If the pattern is drawn out, turn the feed balancing dial in the direction of “-”.

Letters and numbers

Example: Pattern “8” (Pattern 060 in Mode 3)

If the pattern is compressed, turn the feed balancing dial in the direction of “+”.

If the pattern is drawn out, turn the feed balancing dial in the direction of “-”.

Stitch balance of the stretch buttonhole

Example: Pattern 030 (Mode 2)

If the right row is denser, turn the dial in the direction of “+”.

If the left row is denser, turn the dial in the direction of “-”.

CARE AND MAINTENANCE

! WARNING:

Turn the power switch off and unplug the machine before cleaning.
Do not dismantle the machine in any way other than as explained in this section.

! CAUTION:

Do not store the machine in a high-humidity area, near a heat radiator, or in direct sunlight. Store the machine in cool dry place.
Clean the outside of the machine with a soft cloth.
Do not use chemical solvents.

Cleaning the Hook Area

Clean the hook area at least once a month.

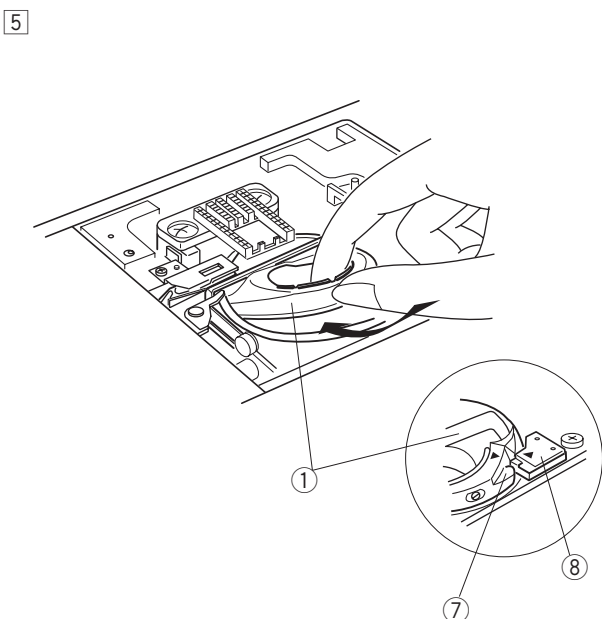
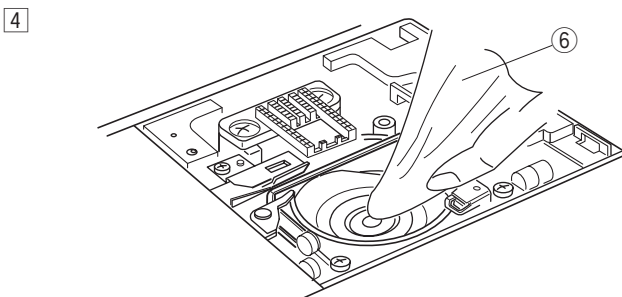
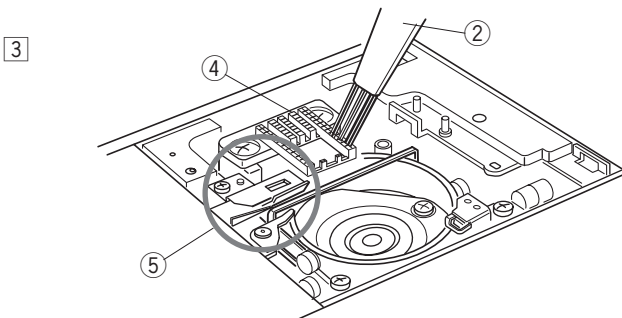
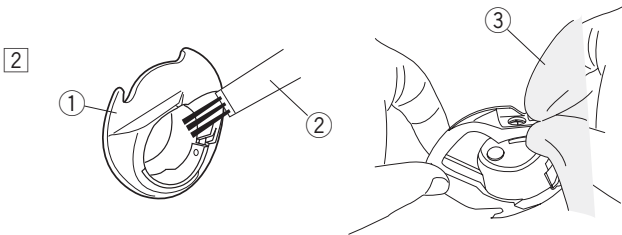
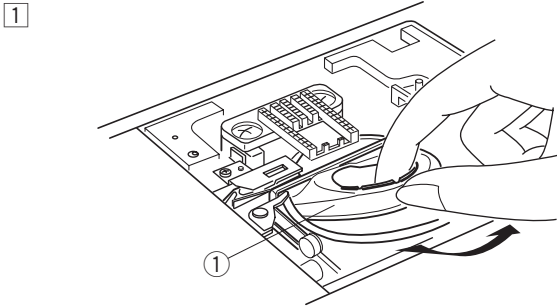

- 1 Turn the power switch off and unplug the machine.
Remove the needle plate (refer to page 26).
Remove the needle and presser foot.
Take out the bobbin and bobbin holder.
 - 1 Bobbin holder
- 2 Clean the bobbin holder with a lint brush.
Wipe the bobbin holder both inside and outside with a soft cloth.
 - 2 Lint brush
 - 3 Soft cloth
- 3 Clean the feed dog and auto thread cutter device with the lint brush.
 - 4 Feed dog
 - 5 Auto thread cutter device
- 4 Clean the hook race with a soft cloth.
 - 6 Soft cloth
- 5 Insert the bobbin holder so that the knob fits next to the stopper in the hook race.
Insert the bobbin.
Attach the needle plate, presser foot and needle.
 - 7 Knob
 - 8 Stopper

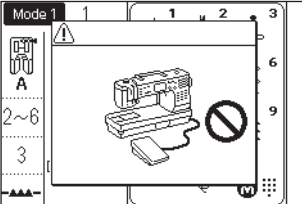
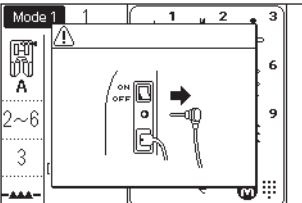
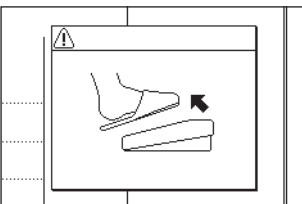
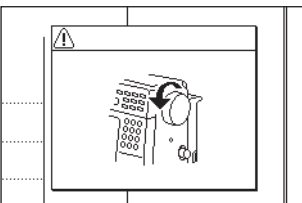
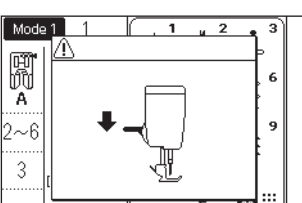
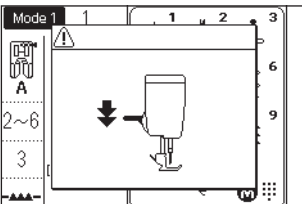
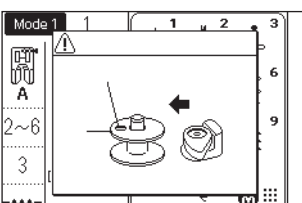
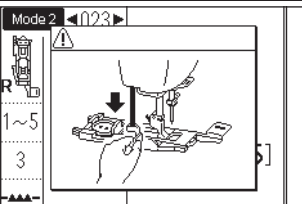

Problems and Warning Signals

If a buzzer sounds and the LCD screen shows a warning sign, follow the guidance below.

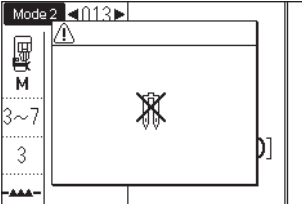
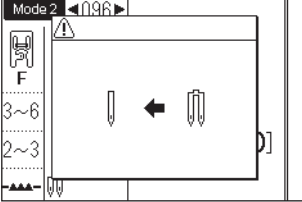
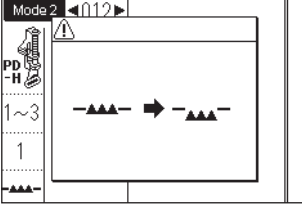
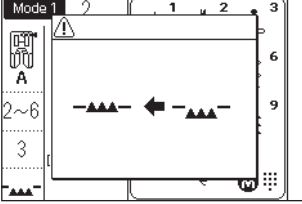
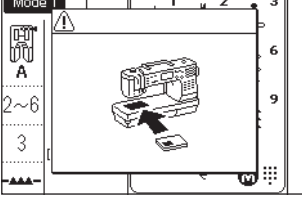
Warning Sign	Cause	Try this
	The foot control is out of order.	Contact the service center or the store from whom the machine was purchased.
	The start/stop key is pressed with the foot control connected.	Disconnect the foot control.
	The power is turned on while depressing the foot control	Release the foot control.
	The machine is turned on with the needle in the down position.	Turn the handwheel to raise the needle.
	The machine is started without lowering the presser foot.	Lower the presser foot and start the machine.
	The presser foot is raised while sewing.	
	The bobbin winding key is pressed when bobbin winder stopper is at the right position.	Shift the bobbin winder stopper to the left for bobbin winding.
	The machine is started without lowering the buttonhole lever.	Lower the buttonhole lever and start the machine again.

Warning Sign	Cause	Try this
	<p>The twin needle key is pressed when a pattern unsuitable for twin needle sewing has been selected.</p>	<p>Select the pattern suitable for twin needle sewing.</p>
	<p>The twin needle has to be replaced with a single needle.</p>	<p>Replace the twin needle with a single needle, then press the twin needle key.</p>
	<p>The machine is started without lowering the feed dog with basting or button sewing selected.</p>	<p>Lower the feed dog.</p>
	<p>The machine is started with the feed dog lowered.</p>	<p>Raise the feed dog.</p>
	<p>The needle plate is removed.</p>	<p>Attach the needle plate. Check if the needle plated is attached properly.</p>
	<p>The machine is halting due to the overload.</p>	<p>Wait for at least 15 seconds to restart. Remove tangled threads around take-up lever, hook race and automatic thread cutting mechanism. Check also if the needle is bent or the fabric is too thick.</p>

Troubleshooting

Condition	Cause	Reference
The needle thread breaks	<ol style="list-style-type: none"> 1. The needle thread is not threaded properly. 2. The needle thread tension is too tight. 3. The needle is bent or blunt. 4. The needle is incorrectly inserted. 5. The needle thread is not set under the presser foot when start sewing. 6. The fabric is moved too fast when stitching free motion quilting. 7. The thread is tangled around the spool. 	Page 22-23 Page 27 Change the needle. Page 17 Page 37 Page 78 Use the spool holder.
The bobbin thread breaks	<ol style="list-style-type: none"> 1. The bobbin thread is not threaded properly in the bobbin holder. 2. Lint has collected in the bobbin holder. 3. The bobbin is damaged and does not turn smoothly. 	Page 21 Page 99 Change the bobbin.
The needle breaks	<ol style="list-style-type: none"> 1. The needle is incorrectly inserted. 2. The needle is bent. 3. The needle clamp screw is loose. 4. The fabric is pulled forward when using the open-toe foot. 5. The needle is too fine for the fabric being used. 6. An inappropriate presser foot is used. 	Page 17 Change the needle. Page 17 Page 77 Page 17 Use the correct foot.
Skipped stitches	<ol style="list-style-type: none"> 1. The needle is incorrectly inserted, bent or blunt. 2. The needle and/or threads are not suitable for the work being sewn. 3. A blue tip needle is not being used for sewing stretch, very fine fabrics and synthetics. 4. The needle thread is not threaded properly. 5. A poor quality needle is used. 6. A purple tip needle is not being used for sewing thick fabrics, denims and across the hem. 	Page 17 Page 17 Use the stretch stitch needle. Page 22-23 Change the needle. Page 17
Seam puckering	<ol style="list-style-type: none"> 1. The needle thread tension is too tight. 2. The needle thread is not threaded properly. 3. The needle is too heavy for the fabric being sewn. 4. The stitch length is too long for the fabric. 5. The foot pressure is not adjusted properly. 6. A stabilizer is not used when sewing very fine fabrics. 	Page 27 Page 22-23 Page 17 Make stitch shorter. Page 15 Apply a stabilizer.
The fabric is not feeding smoothly	<ol style="list-style-type: none"> 1. The feed dog is packed with lint. 2. The stitches are too fine. 3. The feed dog is not raised after "drop feed" sewing. 	Page 99 Make stitch longer. Page 28
Loops on the seams	<ol style="list-style-type: none"> 1. The needle thread tension is too loose. 2. The needle is too thick or too fine for the fabric. 	Page 27 Page 17
The machine does not run	<ol style="list-style-type: none"> 1. The machine is not plugged in. 2. Thread has been caught in the hook race. 3. The start/stop key is used for ordinary sewing with the foot control plugged in. 	Page 8 Page 99 Page 8
Buttonhole sewing is not sewn properly	<ol style="list-style-type: none"> 1. The stitch density is not suitable for the fabric being sewn. 2. The interfacing has not been used for the stretch or synthetic fabric. 3. The buttonhole lever is not lowered. 	Page 61 Apply an interfacing. Page 59
The machine is noisy	<ol style="list-style-type: none"> 1. Thread has been caught in the hook race. 2. Lint has built up in the hook race or bobbin holder. 	Page 99 Page 99
Auto thread cutting failed	<ol style="list-style-type: none"> 1. Thread is too thick for the auto thread cutting. 2. Threads have been caught in the thread cutter mechanism. 	Page 10 Page 99
The needle thread appears on the wrong side of the fabric when the stitch width value is larger than "7.0".	<ol style="list-style-type: none"> 1. Thread tension is not balanced. 	Page 27

It is not abnormal for a faint humming sound to be heard from the internal motors.

The LCD screen and function key area may become warm after several hours of continuous use.

