

Instruction Book

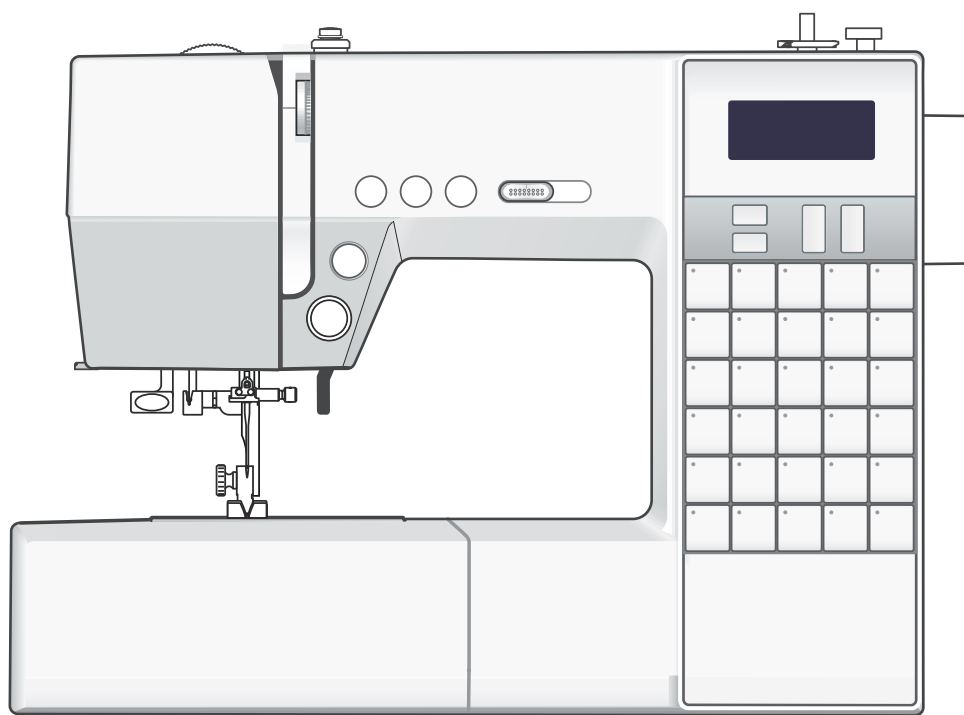

JANOME

IMPORTANT SAFETY INSTRUCTIONS

This appliance is not intended for use by persons (including children) with reduced physical, sensory or mental capabilities, or lack of experience and knowledge, unless they have been given supervision or instruction concerning use of the appliance by a person responsible for their safety.

Children should be supervised to ensure that they do not play with this sewing machine.

When using an electrical appliance, basic safety precautions should always be followed, including the following:

This sewing machine is designed and manufactured for household use only.

Read all instructions before using this sewing machine.

DANGER — To reduce the risk of electric shock:

1. An appliance should never be left unattended when plugged in. Always unplug this sewing machine from the electric outlet immediately after using and before cleaning.

WARNING — To reduce the risk of burns, fire, electric shock, or injury to persons:

1. Do not allow to be used as a toy. Close attention is necessary when this sewing machine is used by or near children.
2. Use this appliance only for its intended use as described in this owner's manual. Use only attachments recommended by the manufacturer as contained in this owner's manual.
3. Never operate this sewing machine if it has a damaged cord or plug, if it is not working properly, if it has been dropped or damaged, or dropped into water. Return this sewing machine to the nearest authorized dealer or service center for examination, repair, electrical or mechanical adjustment.
4. Never operate the appliance with any air opening blocked. Keep ventilation openings of this sewing machine and foot controller free from accumulation of lint, dust and loose cloth.
5. Never drop or insert any object into any opening.
6. Do not use outdoors.
7. Do not operate where aerosol (spray) products are being used or where oxygen is being administered.
8. To disconnect, turn all controls to the off ("O") position, then remove plug from outlet.
9. Do not unplug by pulling on cord. To unplug, grasp the plug, not the cord.
10. Keep fingers away from all moving parts. Special care is required around the sewing machine needle and/or cutting blade.
11. Always use the proper needle plate. The wrong plate can cause the needle to break.
12. Do not use bent needles.
13. Do not pull or push fabric while stitching. It may deflect the needle causing it to break.
14. Switch this sewing machine off ("O") when making any adjustment in the needle area, such as threading the needle, changing the needle, threading the bobbin or changing the presser foot, and the like.
15. Always unplug this sewing machine from the electrical outlet when removing covers, lubricating, or when making any other adjustments mentioned in this owner's manual.

SAVE THESE INSTRUCTIONS

The design and specifications are subject to change without a prior notice.



Please note that on disposal, this product must be safely recycled in accordance with relevant National legislation relating to electrical/electronic products. If in doubt please contact your retailer for guidance.

(European Union only)

TABLE OF CONTENTS

NAMES OF PARTS

Names of Parts	1
Standard Accessories	2

GETTING READY TO SEW

Connecting the Power Supply	3
Using the start/stop button	4
Controlling Sewing Speed	4
Speed control slider	4
Foot control	4
Extension Table	5
Detaching the table	5
Attaching the table	5
Free-arm sewing	5
Accessory storage	5
Machine Operating Buttons	6
Function Buttons & LCD Display	7
Presser Foot Lifter	8
Changing the Presser Foot	8
Removing and Attaching the Foot Holder	8
Presser Foot Pressure Dial	8
Adjusting the Needle Thread Tension	9
Straight stitch	9
Zigzag Stitch	10
Dropping or Raising the Feed Dog	11
Changing the Needle	12
Selecting Thread and Needles	12
Setting the Spool of Thread	13
Horizontal spool pin	13
Extra spool pin	13
Bobbin Winding	13
Winding the bobbin	14
Inserting the bobbin	15
Threading the Machine	16
Needle Threader	17
Drawing up the Bobbin Thread	18

BASIC SEWING

Straight Stitch Sewing	19
Sewing from the edge of thick fabric	19
Changing sewing direction	20
Securing seam	20
Auto Thread Cutting	20
Using Seam Guides	21
Turning a square corner	21
Altering the needle drop position	22
Altering the stitch length	22
Straight stitch	23
Lock-a-matic stitch	23
Locking stitch	23
Triple stretch stitch	24
Stretch stitch	24
Saddle stitch	24

Zigzag Stitches	25
Altering the stitch width	25
Altering the stitch length	25
Overcasting with zigzag stitch	25
Multiple zigzag stitch	26
Overedge stitch	26
Double overedge stitch	26
Buttonholes	27
Square buttonhole	27
Double layer buttonhole	29
Using the stabilizer plate	30
Adjusting the width and density for buttonholes	31
Round-end buttonhole	31
Keyhole buttonhole	31
Corded buttonhole	32
Tacking	33
Eyelet	34
Zipper Sewing	35
Attaching the zipper foot	35
Fabric preparation	35
Start sewing	36
Blind Hemming	38
Adjusting the needle drop position	38
Button Sewing	39
Gathering	39

DECORATIVE STITCHING

Patchwork Piecing	40
Patchwork	40
Shelltuck Tuck	41
Applique	41
Fringing	42
Cross Stitch	42
Fagoting	43
Scallop Stitch	43
Smocking	44
Pintucking	44
Satin Stitches	45
Decorative Stretch Stitches	45
Twin Needle Sewing	46
Threading the machine for twin needle	46
Selecting the patterns	47
Sewing	47

MACHINE SETTINGS

Machine Setting Mode	48
Buzzer sound setting	48
Needle stop position setting	48
Correcting Deformed Stitch Patterns	48

CARE OF YOUR MACHINE

Cleaning the Hook Race and Feed Dog	49
Installing the Bobbin Holder	49
Problems and Warning Signs	50
Troubleshooting	51

NAMES OF PARTS

Names of Parts

- ① Upper thread guide
- ② Bobbin winding tension disk
- ③ Spool holder (large)
- ④ Spool pin
- ⑤ Hole for additional spool pin
- ⑥ Bobbin winder spindle
- ⑦ Bobbin winder stopper
- ⑧ Bobbin thread holder/cutter
- ⑨ LCD display
- ⑩ Stitch length adjusting buttons
- ⑪ Stitch width adjusting buttons
- ⑫ Elongation button
- ⑬ Twin needle button
- ⑭ Pattern selection buttons
- ⑮ Speed control slider
- ⑯ Thread cutter button
- ⑰ Needle up/down button
- ⑱ Auto-lock button
- ⑲ Reverse stitch button
- ⑳ Start/stop button
- ㉑ Extension table (Accessory box)
- ㉒ Thread cutter
- ㉓ Face cover
- ㉔ Thread tension dial
- ㉕ Presser foot pressure dial
- ㉖ Thread take-up lever
- ㉗ Lower thread guide
- ㉘ Needle clamp screw
- ㉙ Needle
- ㉚ Presser foot
- ㉛ Hook cover release button
- ㉜ Hook cover plate
- ㉝ Needle plate
- ㉞ Feed dogs
- ㉟ Foot holder
- ㊱ Needle threader
- ㊲ Buttonhole lever
- ㊳ Carrying handle
- ㊴ Free-arm
- ㊵ Drop feed lever
- ㊶ Presser foot lifter
- ㊷ Machine socket
- ㊸ Foot control jack
- ㊹ Power switch
- ㊺ Ventilation openings
- ㊻ Handwheel
- ㊼ Feed balancing dial

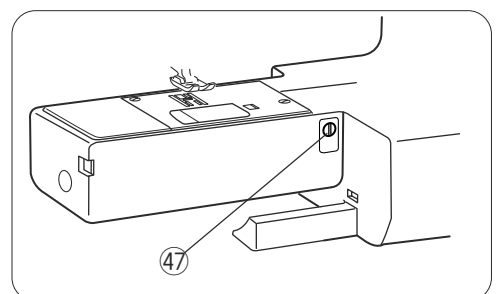
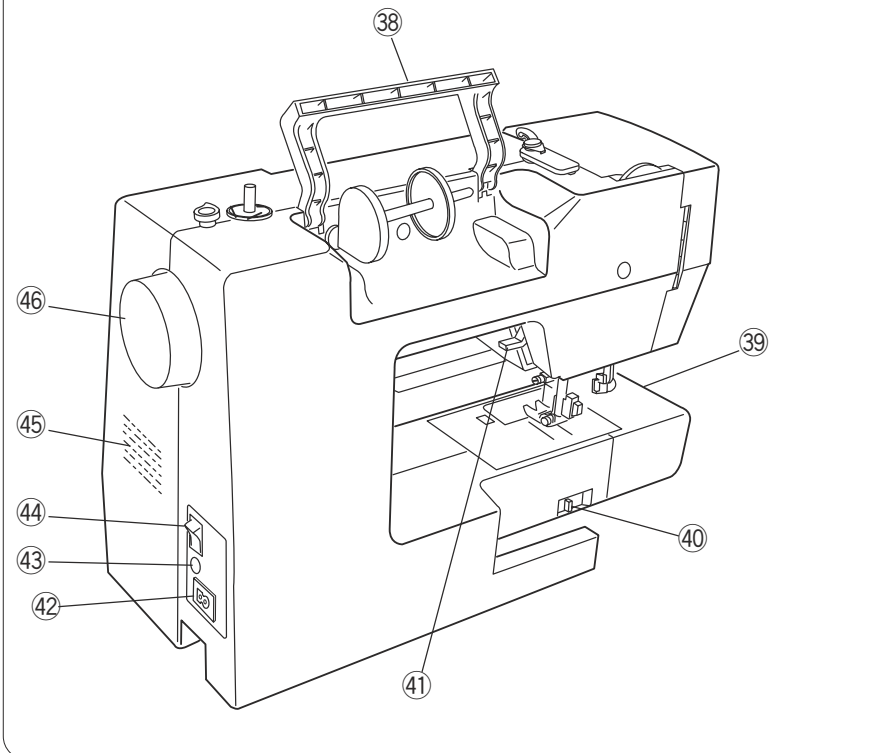
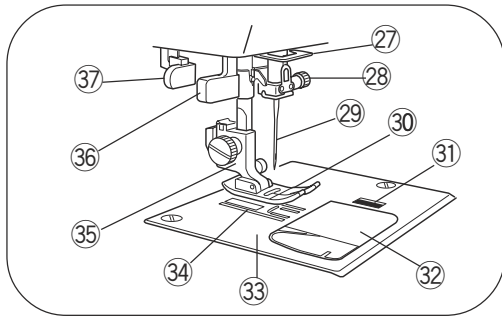
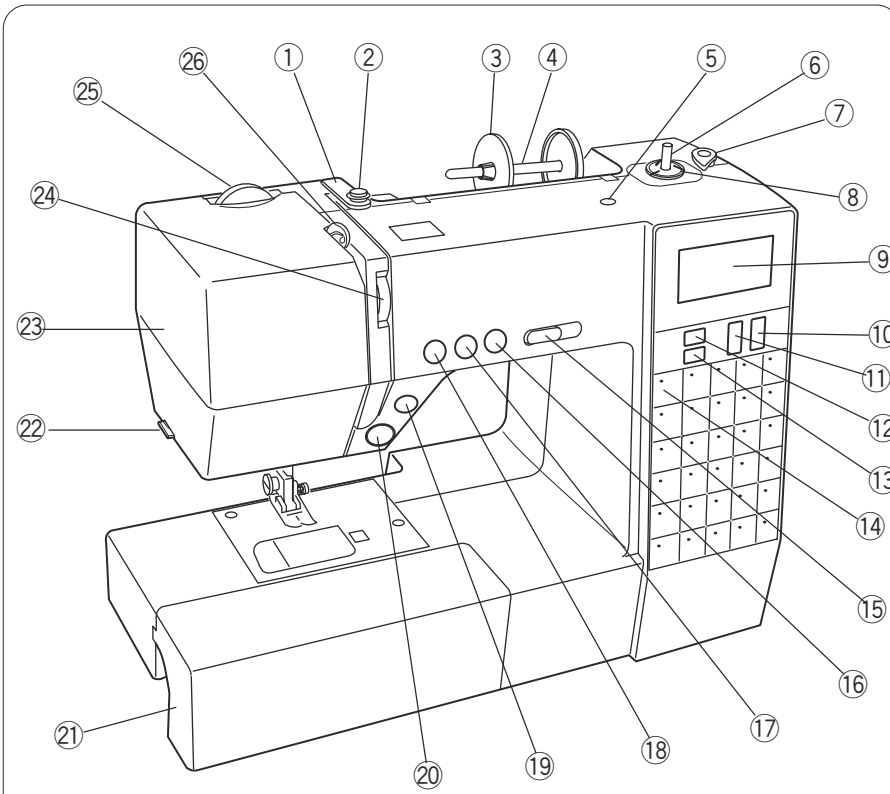

Standard Accessories

- ① Zigzag foot: A (set on the machine)
- ② Overedge foot: C
- ③ Zipper foot: E
- ④ Satin stitch foot: F
- ⑤ Blind hem foot: G
- ⑥ 1/4" seam foot: O
- ⑦ Automatic buttonhole foot: R
- ⑧ Buttonhole stabilizer plate
- ⑨ Spool holder (X 2) (large)
- ⑩ Spool holder (X 2) (small)
- ⑪ Additional spool pin
- ⑫ Bobbins (X 4)
- ⑬ Assorted needle set
- ⑭ Seam ripper (Buttonhole opener)
- ⑮ Lint brush
- ⑯ Screwdriver

- ⑰ Instruction book
- ⑱ Instructional DVD
- ⑲ Foot control
- ⑳ Power supply cable

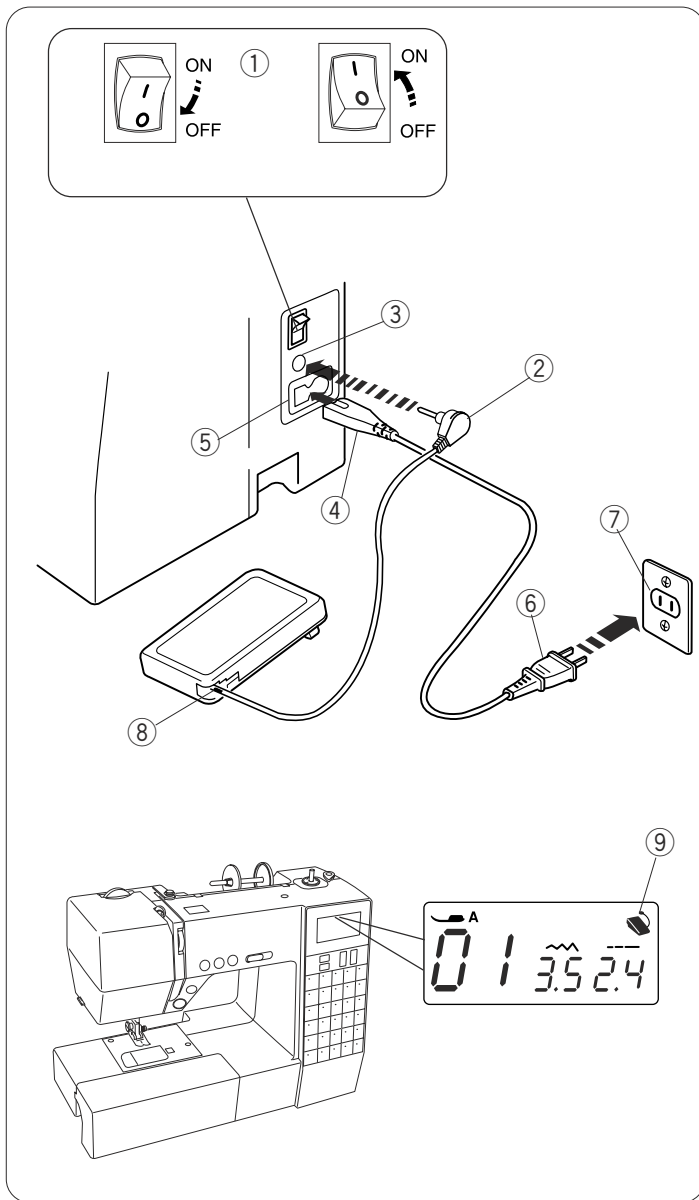

GETTING READY TO SEW

Connecting the Power Supply

• Using the foot control

Turn off the power switch.

Pull out the foot control cable gently. Insert the foot control plug into the foot control jack.

Insert the machine plug into the machine socket.

Insert the power supply plug into the wall outlet.

Turn on the power switch.

- ① Power switch
- ② Control plug
- ③ Foot control jack
- ④ Machine plug
- ⑤ Machine socket
- ⑥ Power supply plug
- ⑦ Wall outlet

CAUTION:

Do not pull the foot control cable beyond the red mark to damage to the foot control.

- ⑧ Red mark

The foot control sign will be displayed when the foot control is connected to the machine.

- ⑨ Foot control sign

⚠ WARNING:

While in operation, always keep your eyes on the sewing area and do not touch any moving parts such as the thread take-up lever, handwheel or needle. Always turn off the power switch and unplug from the power supply:

- when leaving the machine unattended.
- when attaching or removing parts.
- when cleaning the machine.

Do not place anything on the foot control, otherwise the machine will run inadvertently.

Operating Instructions:

The symbol "O" on the switch indicates the "off" position.

For appliances with a polarized plug (one blade wider than the other): To reduce the risk of electric shock, this plug is intended to fit in a polarized outlet only one way.

If it still does not fit, contact a qualified electrician to install the proper outlet. Do not modify the plug in any way (U.S.A. and Canada only).

Foot control model 21371 is used with this sewing machine.

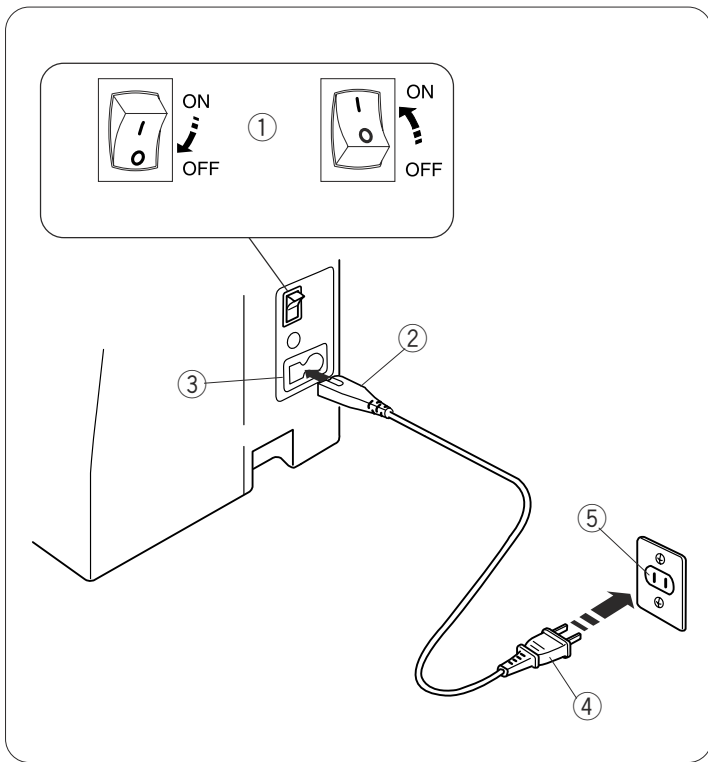

• Using the start/stop button

Turn off the power switch.

Insert the machine plug into the machine socket.

Insert the power supply plug into the wall outlet.

Turn on the power switch.

- ① Power switch
- ② Machine plug
- ③ Machine socket
- ④ Power supply plug
- ⑤ Wall outlet
- ⑥ Start/Stop button

NOTE:

The start/stop button does not work when the foot control is connected.

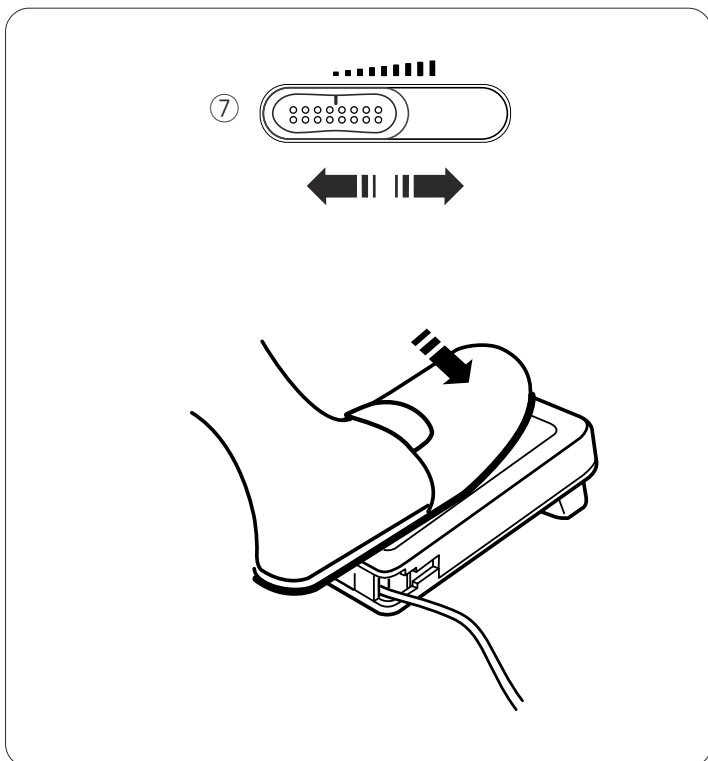
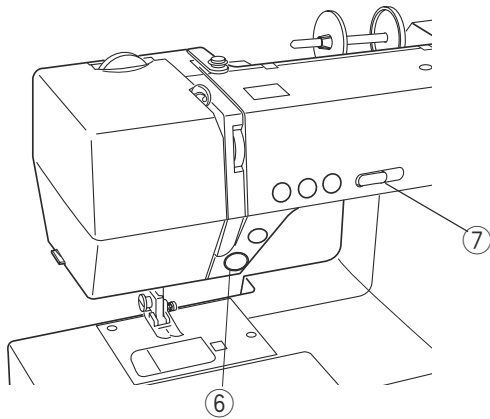

Controlling Sewing Speed

Speed control slider

Sewing speed can be varied by the speed control slider according to your sewing needs.

To increase sewing speed, slide the slider to the right.

To decrease sewing speed, slide the slider to the left.

- ⑦ Speed control slider

Foot control

Depress the foot control to start the machine.

The further down you press on the foot control, the faster the machine runs.

The maximum sewing speed can be varied by the speed control slider.

Extension Table

The extension table provides an extended sewing area and can be easily removed for free-arm sewing.

Detaching the table

Pull the table away from the machine, as illustrated.

- ① Extension table

Attaching the table

Slide the extension table along the free-arm and insert the guides into the holes until the table snaps into the machine.

- ② Free-arm
- ③ Guide
- ④ Hole

Free-arm sewing

Free-arm is useful for sewing tubular garments and for darning knee or elbow areas.

- ② Free-arm

Accessory storage

Accessories are stored inside the extension table. Pull the lid towards you to open the accessory storage.

- ⑤ Lid
- ⑥ Accessory storage

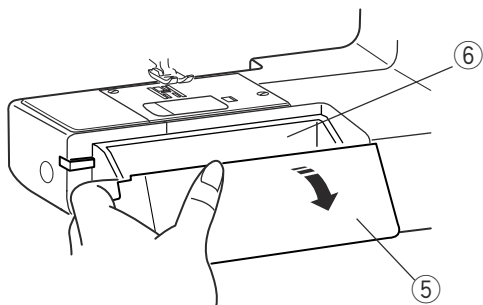
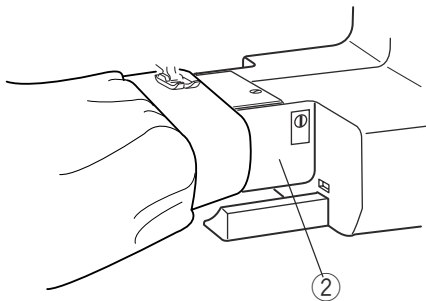
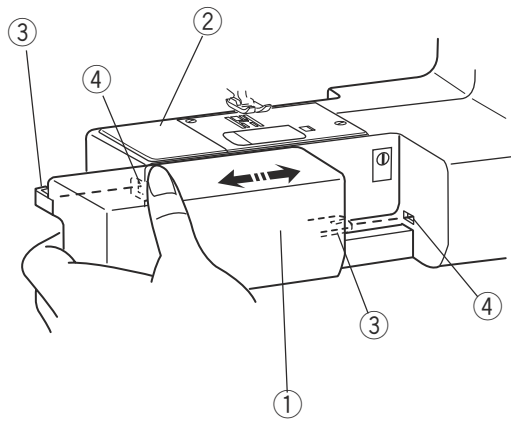

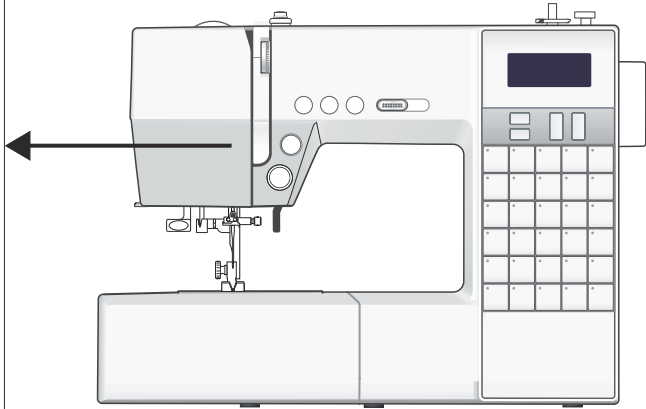
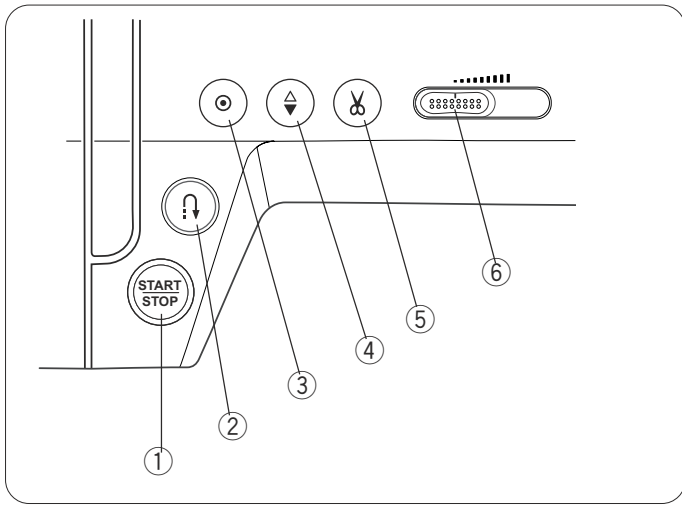

Machine Operating Buttons

① Start/Stop button

Lower the presser foot lifter.

Press the start/stop button to start the machine.

The machine starts running slowly for the first few stitches; it then runs at the speed set by the speed control slider.

Press the start/stop button again to stop the machine.

The button will turn red when the machine is running, and green, when it has been stopped.





NOTES:

The machine runs slowly as long as you press and hold the start/stop button.

The start/stop button cannot be used when the foot control is connected to the machine.

The machine will not run and the presser foot mark will blink if you start the machine with the presser foot in the up position. Lower the presser foot and press the start/stop button.

② Reverse stitch button

• **When pattern 01** , **02** , **07**  or **08**  is selected;



Press and hold the reverse stitch button to sew in reverse. Release the button to sew forward.

Press and hold the button when the machine is stopped and foot control is disconnected to start sewing in reverse slowly. Release the button to stop the machine.





• **When any other stitches are selected;**

Press the reverse stitch button to sew a locking stitch immediately. The machine will automatically stop.

NOTE:

Function of the button will be particular when pattern 03 , 04  or 29  is selected. Refer to page 23, 33, for instructions.

③ Auto-lock button

• **When pattern 01** , **02** , **07**  or **08**  is selected;

Press the auto-lock button to sew a locking stitch immediately. The machine will automatically stop.

• **When any other stitches are selected;**

Press the auto-lock button to sew a locking stitch at the end of current pattern. The machine will automatically stop.

④ Needle up/down button

Press the needle up/down button to bring the needle up or down.

⑤ Thread cutter button

Press the thread cutter button to cut the threads after sewing.

The thread cutter mark will blink while the machine cuts the threads.

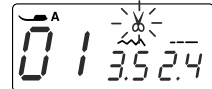

You can continue sewing without pulling the bobbin thread up after trimming the threads.

To cut the threads automatically after sewing, select the desired stitch pattern, then press and hold the thread cutter button until the thread cutter mark appears.

The machine will cut the threads automatically after the locking stitch then stop when the reverse or autolock button is pressed, or a pattern has the built-in auto-lock stitch.

NOTE:

Use the thread cutter on the face cover if the thread is 30 or thicker.

⑥ Speed control slider

Maximum sewing speed can be adjusted with the speed control slider. Refer to page 4.

Function Buttons & LCD Display

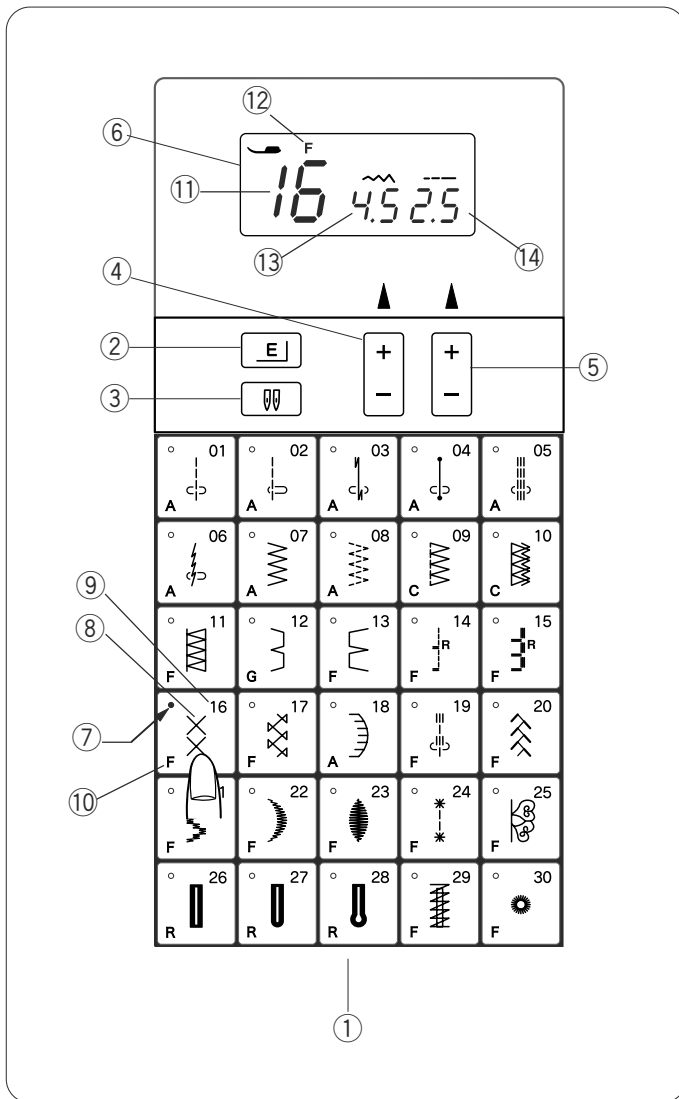

① Pattern selection buttons

Press the pattern selection button to select the desired pattern.

A pattern number and pattern image along with an identification letter of the recommended foot are indicated on each button.

When the pattern is selected a green light on the button will turn on.

- ⑦ Green light
- ⑧ Stitch image
- ⑨ Pattern number
- ⑩ Recommended foot

② Elongation button

Satin stitches, patterns 21, 22 and 23 can be elongated up to five times their normal length by pressing the elongation button. Refer to page 45.

③ Twin needle button

Press this button when using a twin needle.

The twin needle mark will appear and the maximum stitch width will be limited to 3.0.

To cancel or finish the twin needle sewing, press the twin needle button twice.

NOTE:

When the twin needle mark is blinking, all the other buttons and buttons will not respond. Press the twin needle button again.

For twin needle sewing, refer to pages 46, 47.

④ Stitch width adjusting button

Press "+" or "-" to change the stitch width. Refer to pages 22, 25 and 31.

⑤ Stitch length adjusting button

Press "+" or "-" to change the stitch length. Refer to pages 22, 25 and 31.

⑥ LCD Display

The LCD display shows the following information when the machine is turned on:

- ① Pattern number
- ② Recommended presser foot
- ③ Stitch width
- ④ Stitch length

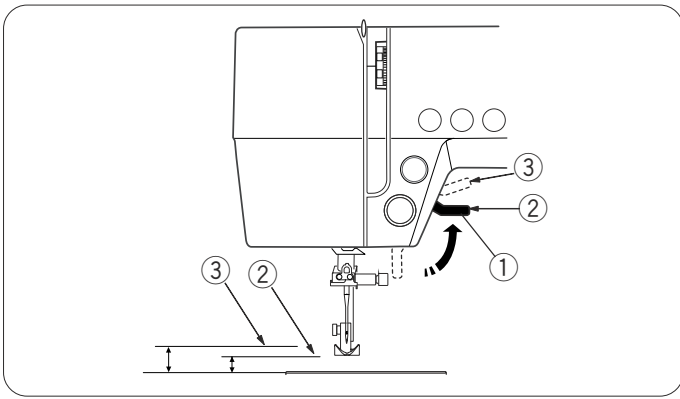

Presser Foot Lifter

The presser foot lifter raises and lowers the presser foot. You can raise the foot about 1/4" (0.6 cm) higher than the normal up position for easy removal of the presser foot, or to help you place thick material under the foot.

- ① Presser foot lifter
- ② Normal up position
- ③ Highest position

Changing the Presser Foot

⚠ CAUTION:

Turn OFF the power switch before changing the foot. Always use the proper foot for the selected pattern. The wrong foot can cause the needle to break. Each foot is marked with an identification letter.

- ① Identification letter

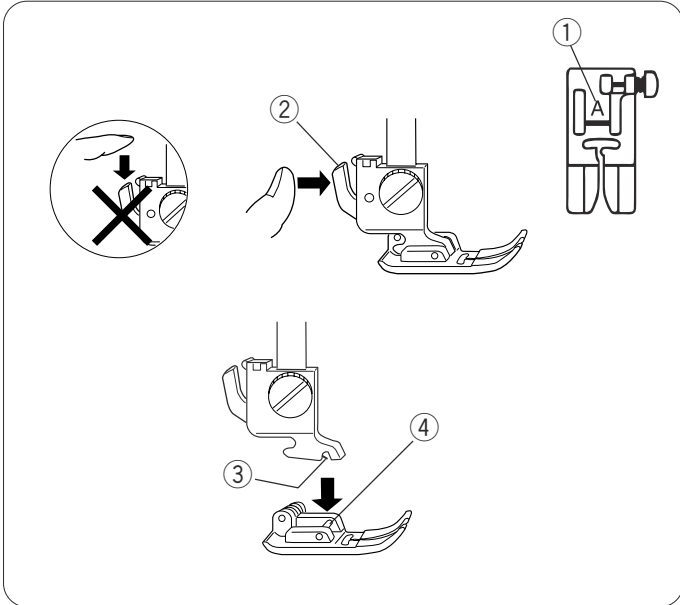

Removing the presser foot

Raise the needle to its highest position by turning the handwheel counterclockwise. Raise the presser foot, and press the lever on the back of the foot holder.

Attaching the presser foot

Place the selected presser foot so that the pin on the foot lies just under the groove in the foot holder. Lower the presser bar to lock the foot into the place.

- ② Lever
- ③ Groove
- ④ Pin

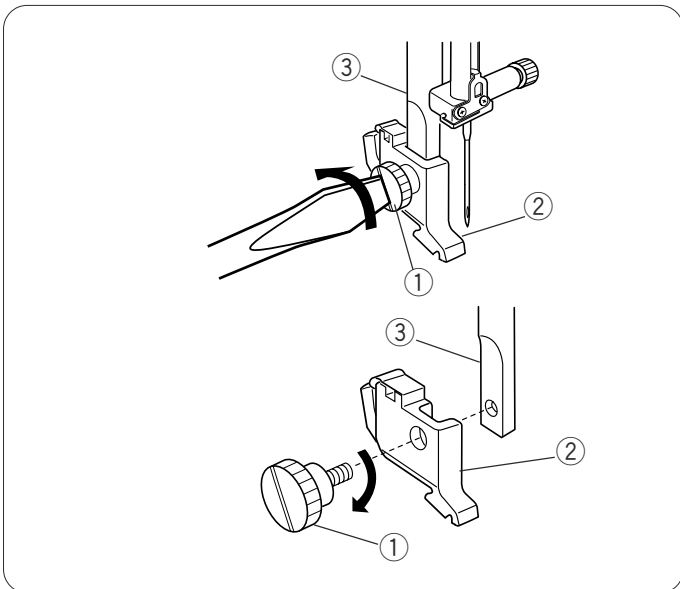

Removing and Attaching the Foot Holder

⚠ CAUTION:

Turn OFF the power switch before detaching or attaching foot holder.

Removing the foot holder

Remove the thumbscrew by turning it counterclockwise with a screwdriver.

Attaching the foot holder

Align the hole in the foot holder with the threaded hole in the presser bar.

Fit the thumbscrew into the hole.

Tighten the thumbscrew by turning it clockwise with a screwdriver.

- ① Thumbscrew
- ② Foot holder
- ③ Presser bar

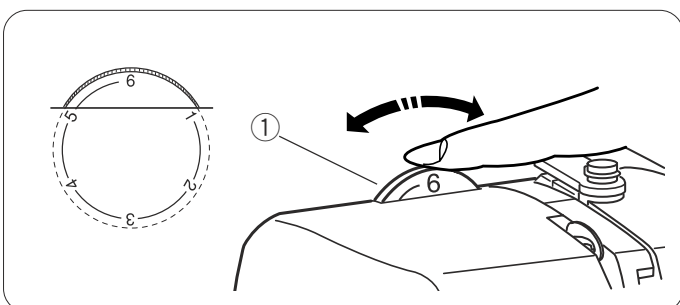

Presser Foot Pressure Dial

Foot pressure can be adjusted by turning the presser foot pressure dial.

Set the pressure between "3" and "6" for ordinary fabrics. Set the pressure between "1" and "3" for fine fabrics and applique sewing.

Set the pressure between "5" and "6" for heavyweight fabrics.

- ① Presser foot pressure dial

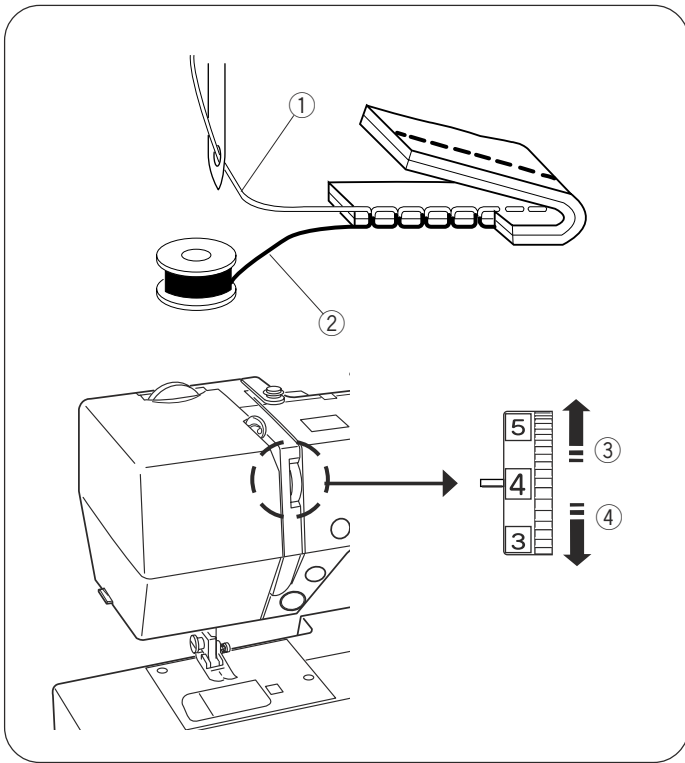

Adjusting the Needle Thread Tension

Straight stitch

• Balanced tension

The ideal straight stitch has threads locked between two layers of fabric, as illustrated (magnified to show detail). If you look at the top and bottom of the seam, notice that the stitches are evenly balanced.

- ① Needle thread (top thread)
- ② Bobbin thread (bottom thread)
- ③ To loosen
- ④ To tighten

When adjusting the needle thread tension, the higher the number, the tighter the top thread tension.

Results depend on:

- stiffness and thickness of the fabric
- number of fabric layers
- type of stitch

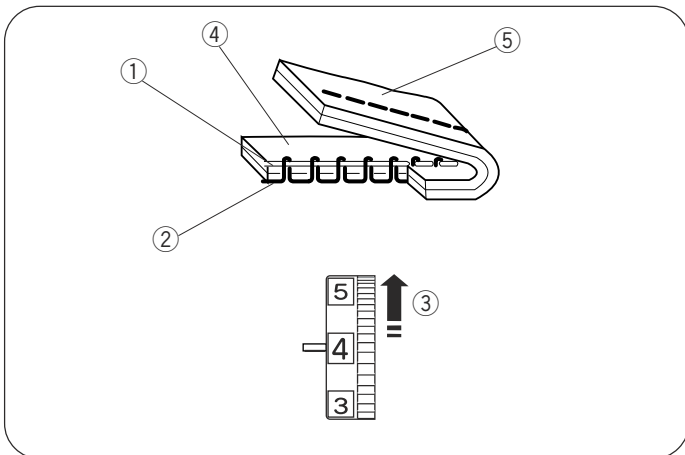

• Tension is too tight

The bobbin thread shows through on the right side of the fabric, and the stitch feels bumpy. Turn the dial to a lower number to loosen the needle thread tension.

- ① Needle thread (top thread)
- ② Bobbin thread (bottom thread)
- ③ To loosen tension
- ④ Right side (top side) of fabric
- ⑤ Wrong side (bottom side) of fabric

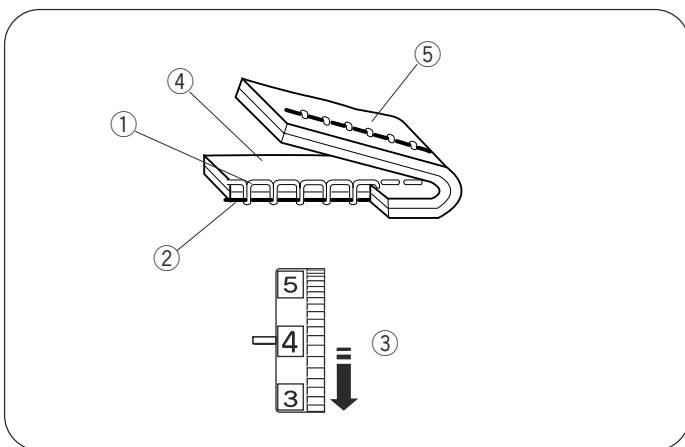

• Tension is too loose

The needle thread shows through on the wrong side of the fabric, and the stitch feels bumpy. Turn the dial to a higher number to tighten the needle thread tension.

- ① Needle thread (top thread)
- ② Bobbin thread (bottom thread)
- ③ To tighten tension
- ④ Right side (top side) of fabric
- ⑤ Wrong side (bottom side) of fabric

Zigzag stitch

For an ideal zigzag stitch, the bobbin thread does not show on the right side (top side) of the fabric, and the needle thread shows slightly on the wrong side (bottom side) of the fabric.

See the illustrations for the correct appearance.

To match this appearance, adjust the needle tension as necessary.

• Balanced tension

Minimize the amount of needle thread visible on the wrong side (bottom side) of the fabric without causing excessive puckering, or causing the bobbin thread to show on the right side (top side) of the fabric.

Results vary with fabric, thread and sewing conditions.

- ① Right side (top side) of fabric
- ② Wrong side (bottom side) of fabric

• Tension is too tight

The corner of each zigzag pulls together on the right side of the fabric

- ① Right side (top side) of fabric
- ② Wrong side (bottom side) of fabric

• Tension is too loose

The corner of each zigzag point pulls together on the wrong side of the fabric.

- ① Right side (top side) of fabric
- ② Wrong side (bottom side) of fabric

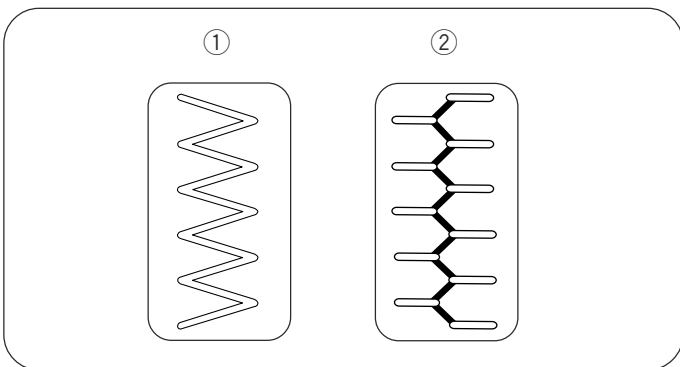
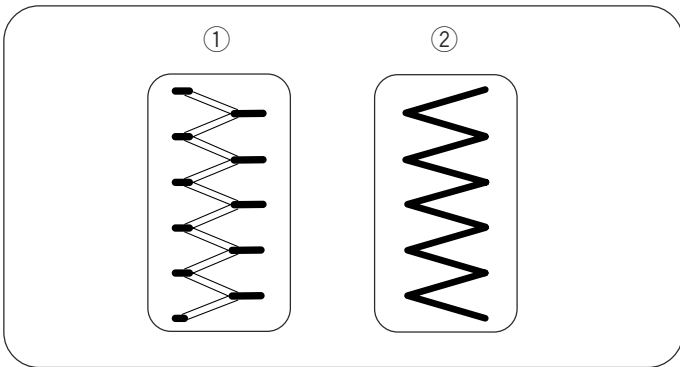
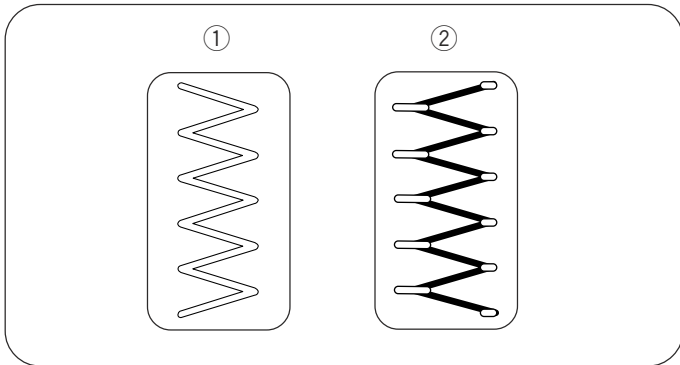

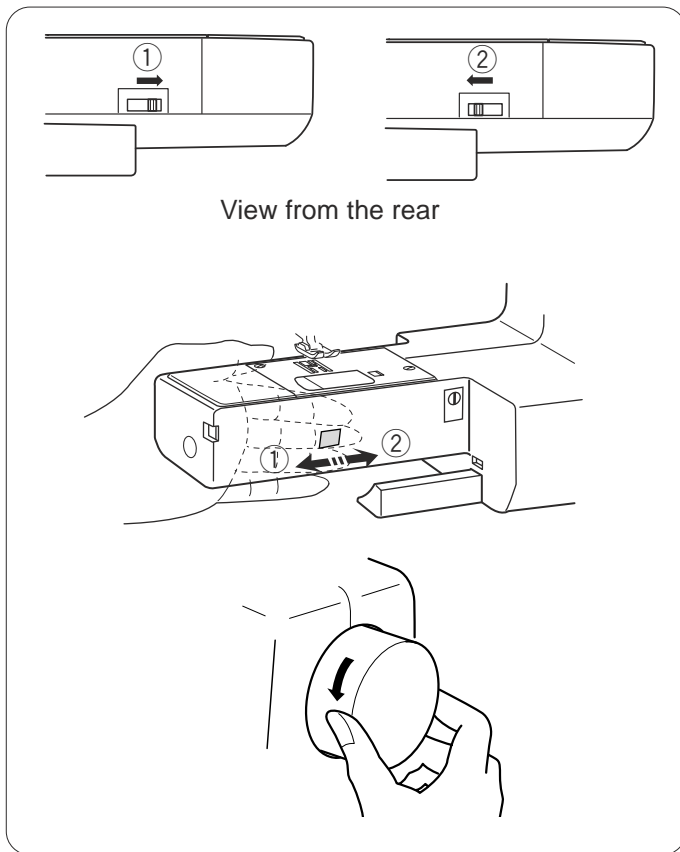

Dropping or Raising the Feed Dog

The drop feed lever is located underneath the free arm bed on the back of the machine.

To drop the feed dog, push the lever in the direction of the arrow ①.

To raise the feed dog, push the lever in the direction of the arrow ②, as illustrated, and turn the handwheel toward you.

The feed dog must be up for normal sewing.

NOTE:

Set the stitch length value at the minimum when lowering the feed dog.

Changing the Needle

⚠ CAUTION:

Turn OFF the power switch before changing the needle. Raise the needle to its highest position by turning the handwheel counterclockwise, and lower the presser foot.

Loosen the needle clamp screw by turning it counterclockwise. Remove the needle from the needle clamp.

Insert a new needle into the needle clamp with the flat side to the rear. When inserting the needle into the needle clamp, push it up as far as it will go.

Tighten the needle clamp screw firmly by turning it clockwise.

- ① Needle clamp screw
- ② Flat side

To see if the needle is in good condition, place the flat side of the needle onto something flat (needle plate, glass etc.). The gap between the needle and the flat surface should be consistent. Never use a bent or blunt needle.

A damaged needle can cause permanent snags or runs in knits, fine silks and silk-like fabrics.

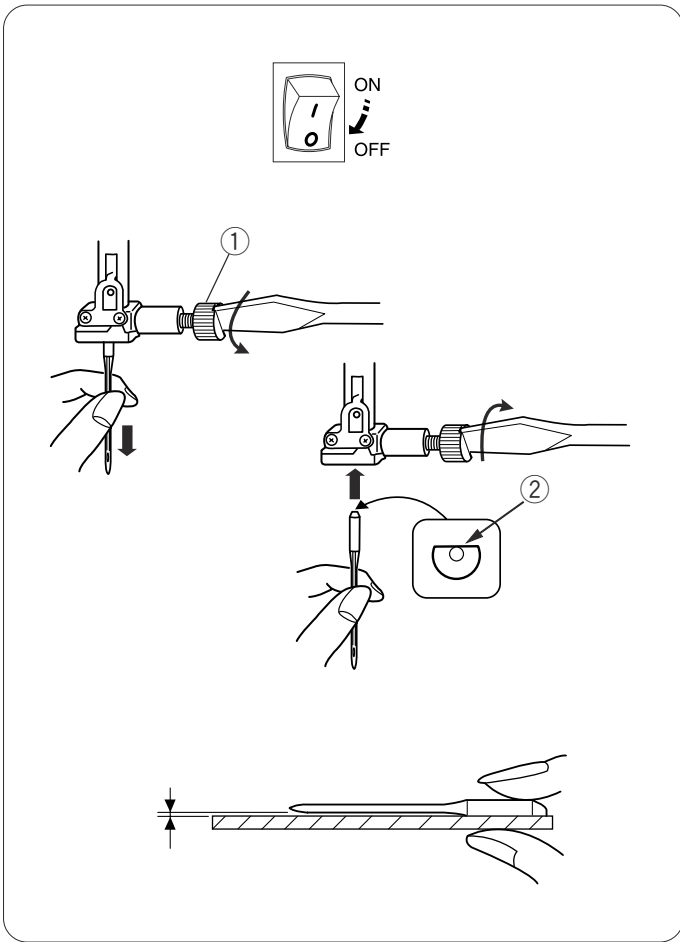

Fabric		Thread	Needle
Light	Lawn	Silk #80-100	#9/65–11/75
	Georgette	Cotton #80-100	
	Tricot	Synthetic #80-100	
	Wool		
	Polyester		
Medium	Cotton	Silk #50	#11/75–14/90
	Polyester	Cotton #60-80	
	Fine jersey	Synthetic #50-80	#14/90
	Wool	Cotton #50	
Heavy	Denim	Silk #50	#14/90–16/100
	Jersey	Cotton #40-50	
	Coating	Synthetic #40-50	#16/100
	Quilting	Silk #30	
		Cotton #50	

Selecting Thread and Needles

For general sewing, use needle size 11/75 or 14/90.

A fine thread and needle should be used for sewing lightweight fabrics, so the fabric will not be marred.

Heavy fabrics require a needle large enough to pierce the fabric without fraying the needle thread.

Always test the needle size on a small scrap of the fabric that will be used for actual sewing.

In general, use the same thread for the needle and bobbin. When sewing stretch fabrics, very fine fabrics and synthetics, use a BLUE TIPPED needle. The blue tipped needle effectively prevents skipped stitches.

Setting the Spool of Thread

Horizontal spool pin

Lift up the spool pin. Place a spool of thread on the spool pin.

Attach the large spool holder, and press it firmly against the spool of thread so that the spool rests on the supporter.

- ① Spool pin
- ② Spool of thread
- ③ Large spool holder
- ④ Supporter

The small spool holder is used with narrow or small spools of thread.

- ⑤ Small spool holder

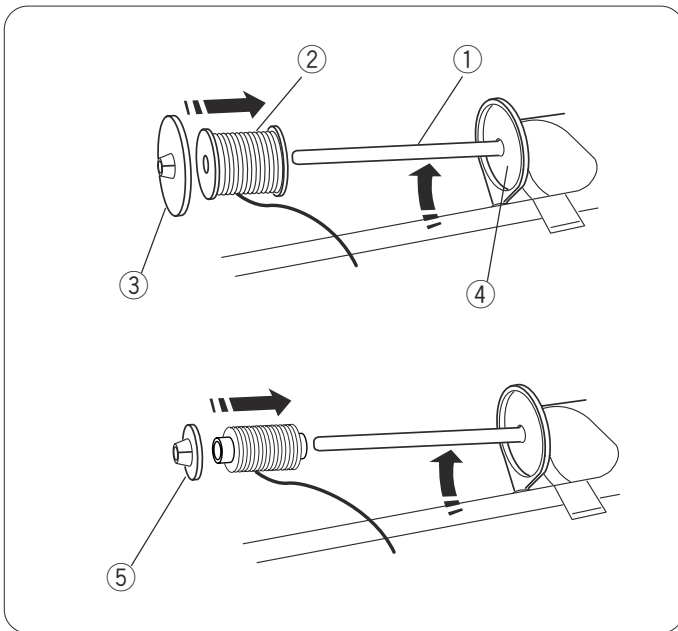

Extra spool pin

The extra spool pin is for twin needle sewing, or winding bobbins without unthreading the machine.

Insert the extra spool pin into the hole.

The extra spool pin should point to the bobbin winder tension disk.

- ⑥ Extra spool pin
- ⑦ Hole for additional spool pin
- ⑧ Bobbin winder tension disk

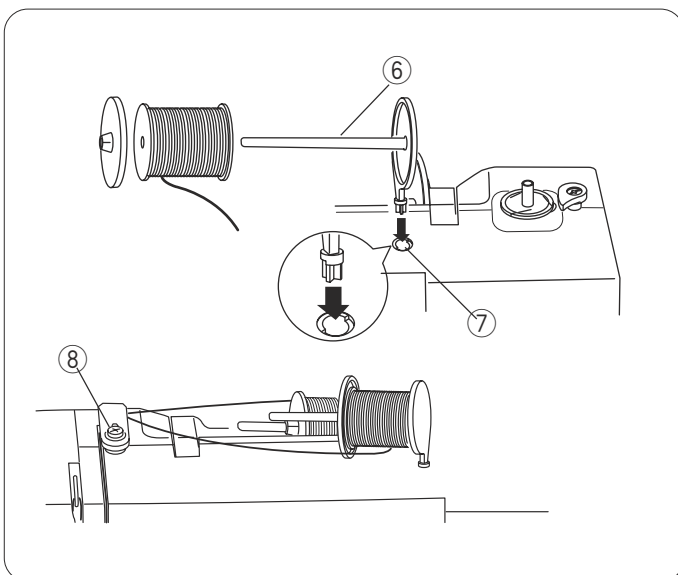

Bobbin Winding

Removing the bobbin

Gently slide the hook cover release button to the right and remove the hook cover plate.

Lift out the bobbin.

- ① Hook cover release button
- ② Hook cover plate
- ③ Bobbin

NOTE:

Use the Janome plastic bobbins. Using other bobbins such as prewound paper bobbins, may cause stitching problems or damage to the bobbin case.

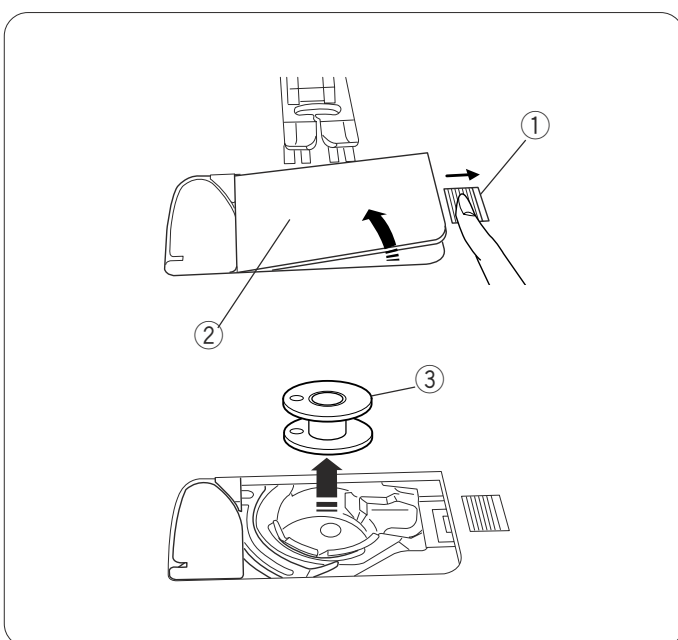

Winding the bobbin

NOTE:

Set the speed control slider at its fastest position for bobbin winding.

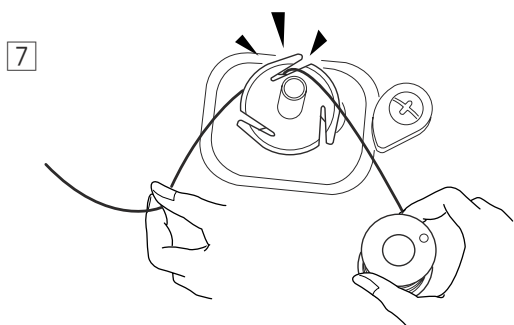
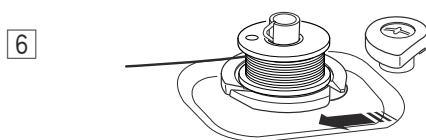
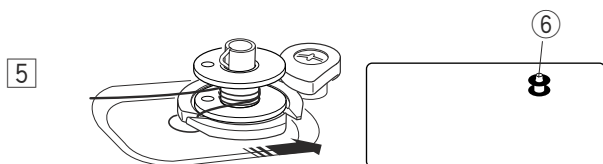
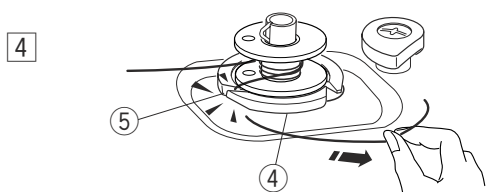
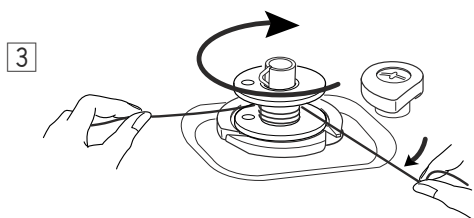
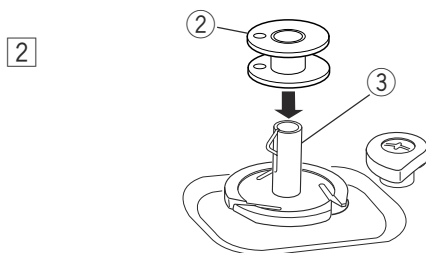
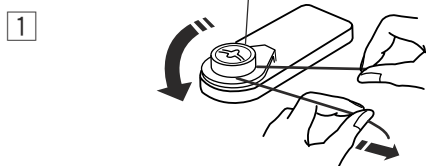
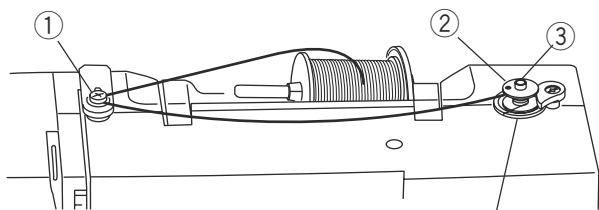

- 1 Draw the thread from the spool and pass the thread around the bobbin winding tension disk.

① Bobbin winding tension disk

- 2 Put the bobbin on the bobbin winder spindle.

② Bobbin

③ Bobbin winder spindle

- 3 Hold the thread with both hands and wind it around the bobbin clockwise several times.

- 4 Insert the thread into one of the 3 slits of the flange plate and pull the thread to cut.

④ Flange plate

⑤ Slit

- 5 Push the bobbin to the right. The bobbin icon appears on the LCD display.

⑥ Bobbin icon

- 6 Start the machine. When the bobbin is fully wound, it will stop spinning automatically.

Stop the machine and return the bobbin winder to its original position by moving the spindle to the left.

- 7 Remove the bobbin. Insert the thread into the slit and pull it to cut as shown.

Inserting the bobbin

⚠ CAUTION:

Turn OFF the power switch before inserting the bobbin and threading the bobbin holder.

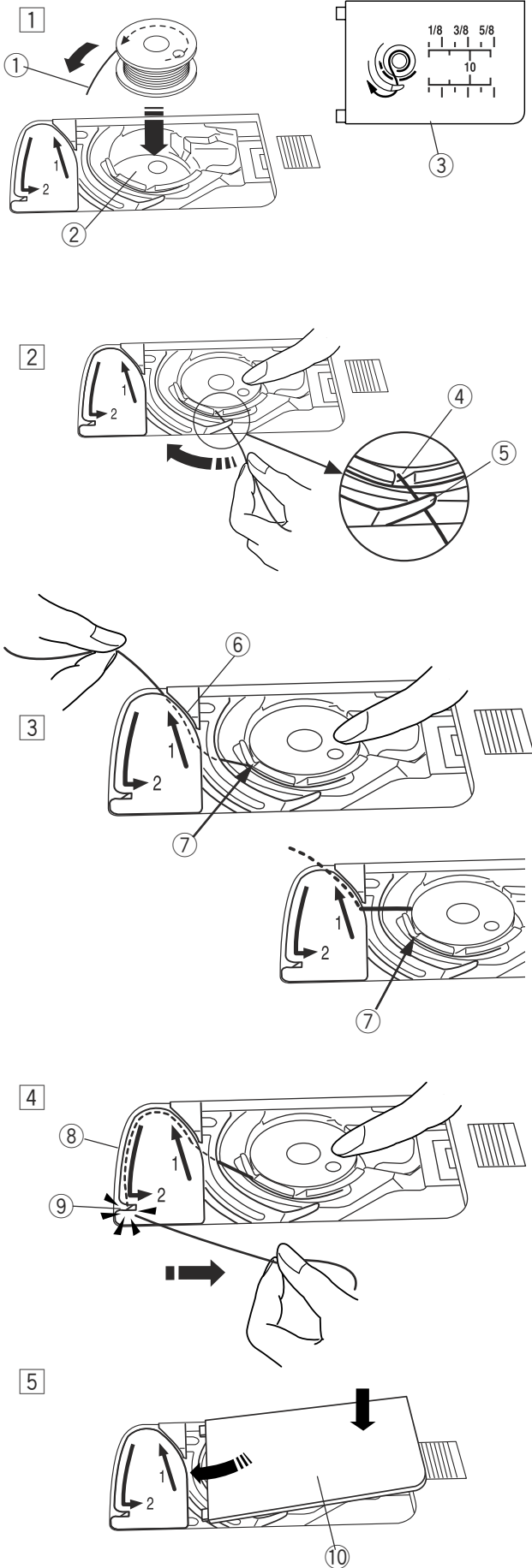

- 1 Place a bobbin in the bobbin holder with the thread running off counterclockwise as shown on the hook cover plate.

- ① End of thread
- ② Bobbin holder
- ③ Hook cover plate

- 2 Hold the bobbin with fingertip so it does not rotate. Guide the thread into the front notch of the bobbin holder.

- Pull the thread to the left to pass it under the guide.
- ④ Front notch
- ⑤ Guide

- 3 Draw the thread to the left to pass it into the guide path marked "1".

Make sure that the thread comes out from the side notch of the bobbin holder.

- ⑥ Guide path 1
- ⑦ Side notch

NOTE:

If the thread does not come out from the side notch, rethread from step 1.

- 4 Continue to draw the thread along the guide path marked "2" and pull the thread to the right through the slit. The thread will be cut to a proper length and held in place.

- ⑧ Guide path 2
- ⑨ Slit (Thread cutter)

- 5 Set the left edge of the hook cover plate into opening. Push down the hook cover plate to fit in place.

- ⑩ Hook cover plate

NOTE:

Unless otherwise noted, you can start sewing without drawing up the bobbin thread.

Refer to page 18 for how to draw up the bobbin thread.

Threading the Machine

Raise the presser foot. Press the needle up/down button to raise the thread take-up lever to its highest position.

CAUTION:
Turn off the power switch before threading the machine.

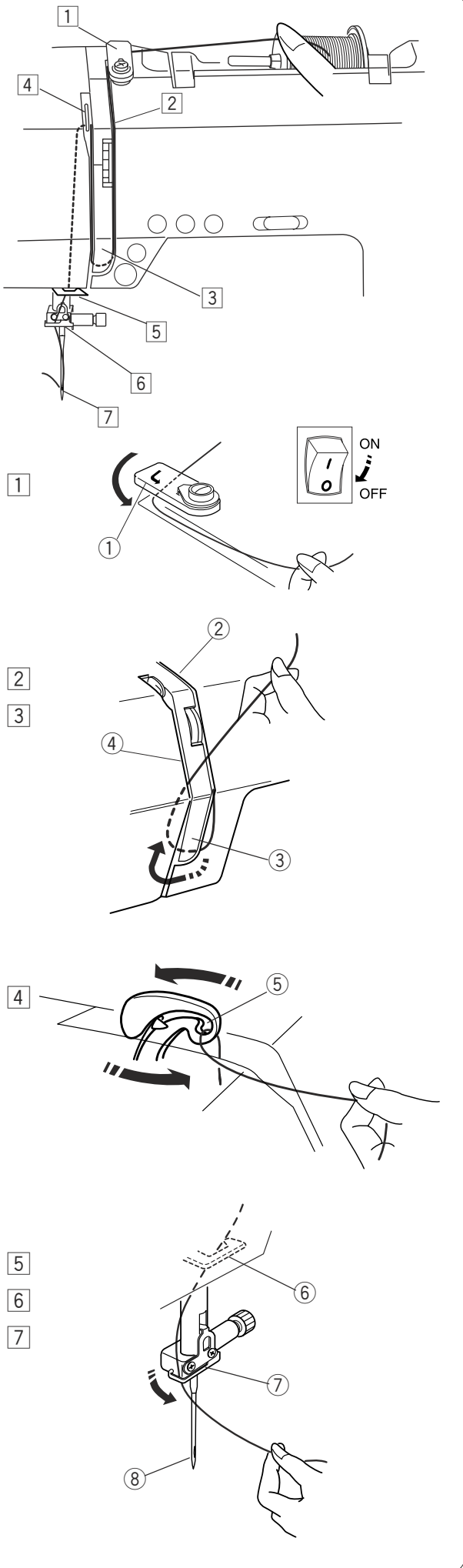

1 Turn the power switch off. Draw the thread around the upper thread guide.

① Upper thread guide

2 While holding the thread near the spool, draw the thread down along the right channel.

② Right channel

3 Pull the thread up around the bottom of the thread guide plate.

Pull the thread up along the left channel.

③ Thread guide plate

④ Left channel

4 Firmly draw the thread up and to the back of the take-up lever. Draw the thread forward to pass it into the take-up lever eye.

⑤ Take-up lever eye

5 Pull the thread down along the left channel and pass the thread through the lower thread guide.

⑥ Lower thread guide

6 Slide the thread behind the needle bar thread guide on the left.

⑦ Needle bar thread guide

7 Thread the needle from front to back, or use the needle threader.

⑧ Needle

Needle Threader

CAUTION:

Turn off the power switch when using the needle threader.

Lower the presser foot. Raise the needle to its highest position.

Pull down the needle threader knob as far as it will go. The hook comes out through the needle eye from behind.

- ① Knob
- ② Hook

Draw the thread from the left guide to the right guide and under the hook.

Draw the thread up along the right side of the right guide and slip the thread in between guide and the holder plate.

- ③ Left guide
- ④ Right guide
- ⑤ Holder plate

Raise the knob in the direction of the arrow, drawing the thread loop through the needle.

- ⑥ Thread loop

Pull the thread through the needle eye.

NOTES:

The needle threader can be used with a #11 to #16 needle or a blue tipped needle. Thread sizes 50 to 90 are recommended.

The needle threader cannot be used for a twin needle.

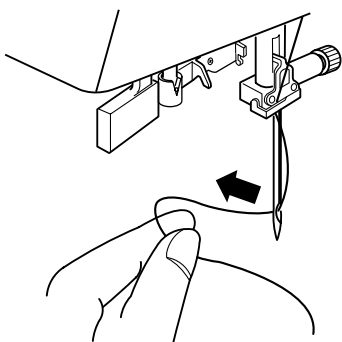
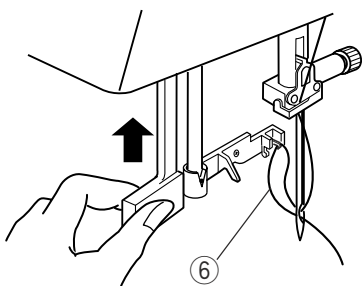
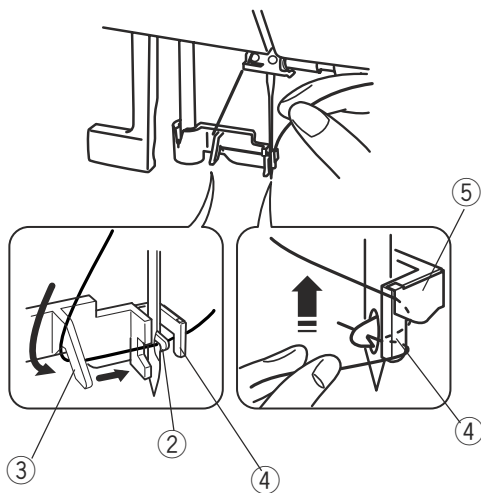
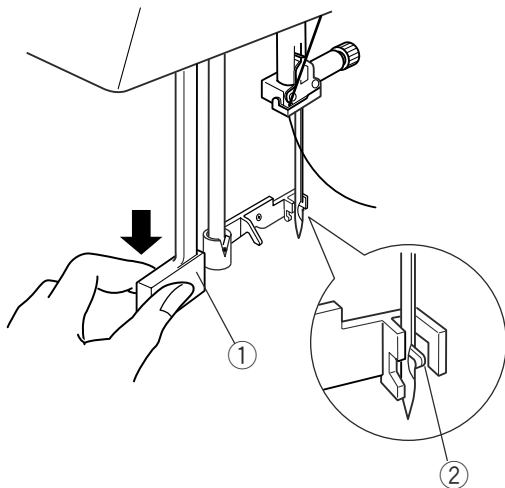

Drawing up the Bobbin Thread

After using auto thread cutting or threading the bobbin holder, you can start sewing without drawing up the bobbin thread.

However, you need to draw up the bobbin thread when sewing gathering stitches etc.

Remove the bobbin. Insert the bobbin into the bobbin again and rethread the bobbin holder according to the instructions on page 15, but leave a 10 cm (4") tail of the bobbin thread as shown.

- ① Bobbin thread

NOTE:

Do not cut the bobbin thread with the thread cutter.

- ② Thread cutter

Raise the presser foot. Hold the needle thread lightly with your left hand.

- ③ Needle thread

Press the needle up/down button twice to lower and raise the needle to pick up the bobbin thread.

- ④ Needle up/down button

Pull both threads 10 cm (4") under and behind the presser foot.

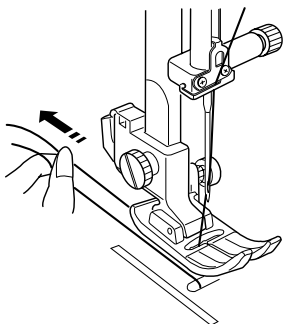
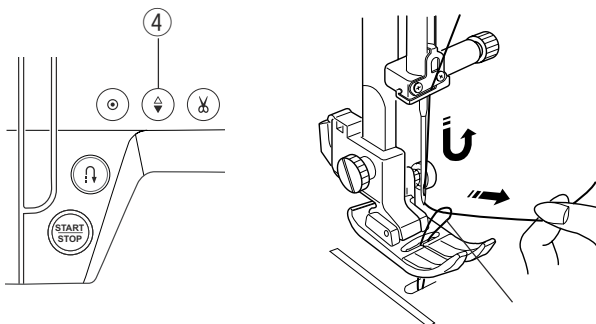
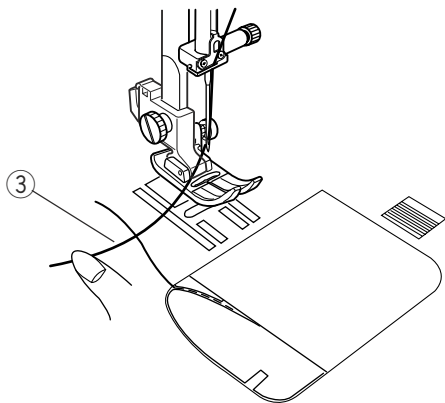
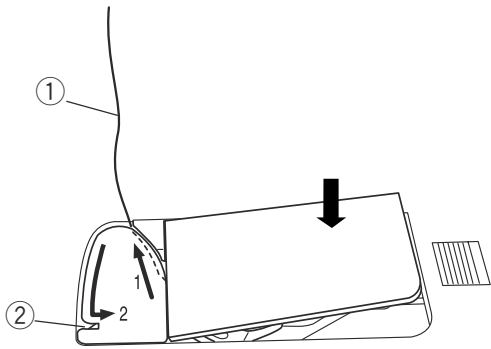

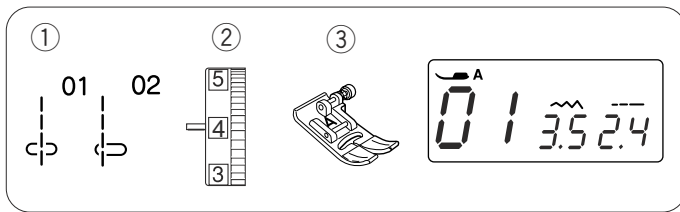

BASIC SEWING

Straight Stitch Sewing

- ① Stitch pattern: 01 or 02
- ② Needle thread tension: 2 to 6
- ③ Presser foot: Zigzag foot A

Starting to sew

Raise presser foot and position the fabric next to a seam guide line on the needle plate. Lower the needle to the point where you want to start.

Pull the thread(s) toward the rear and lower the presser foot.

Press the start/stop button or depress the foot control to start sewing.

Gently guide the fabric along a seam guide line letting the fabric feed naturally.

- ① Start/stop button

To secure the beginning of seam, sew several reverse stitches by pressing the reverse button.

- ② Reverse button

NOTE:

When sewing with the satin stitch foot or buttonhole foot, pull the thread(s) to the left to hold them.

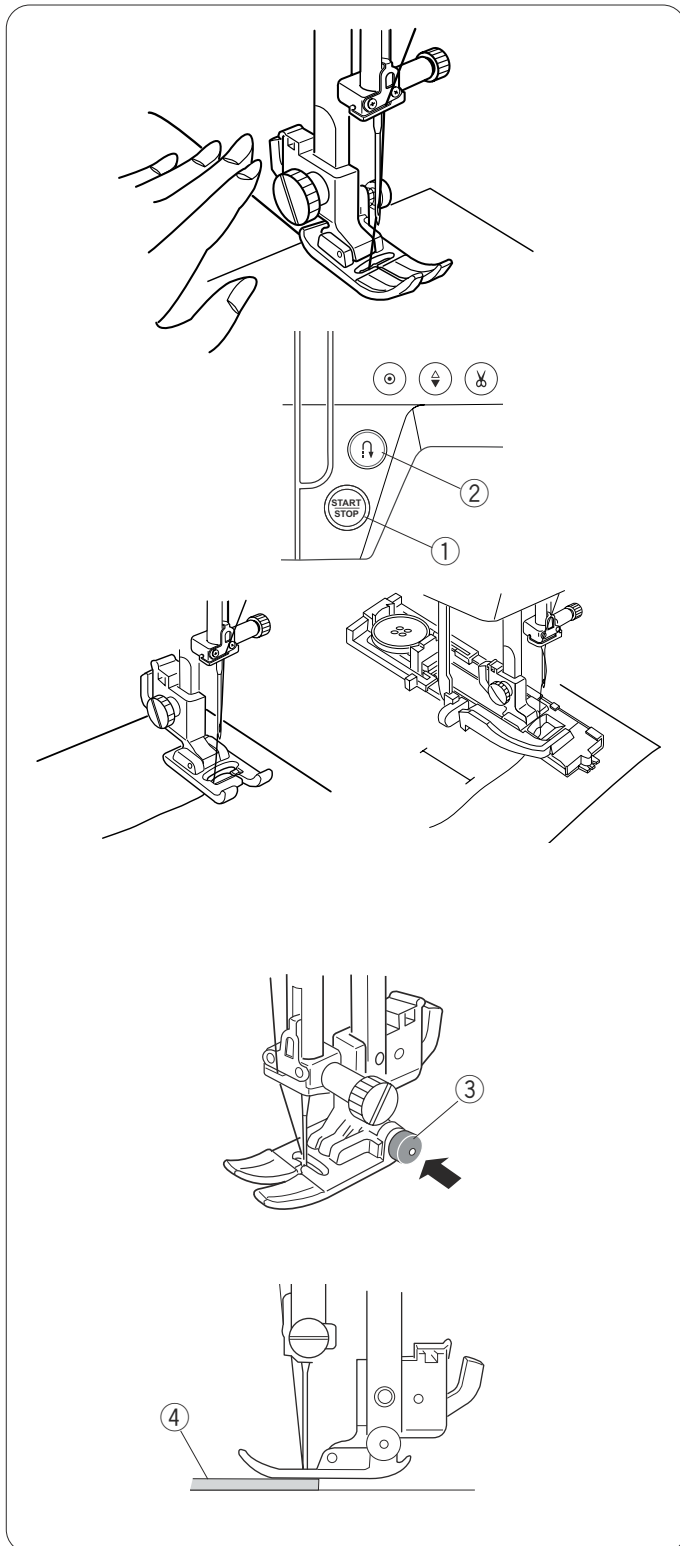

Sewing from the edge of thick fabric

The black button on the zigzag foot locks the foot in the horizontal position.

This is helpful when starting sewing from the far edge of thick fabrics or sewing across a hem.

Lower the needle into the fabric at the point where you wish to start sewing.

Lower the foot while pushing the black button in. The foot is locked in the horizontal position to avoid slipping.

The button is released automatically after sewing a few stitches.

- ③ Black button
- ④ Thick fabrics

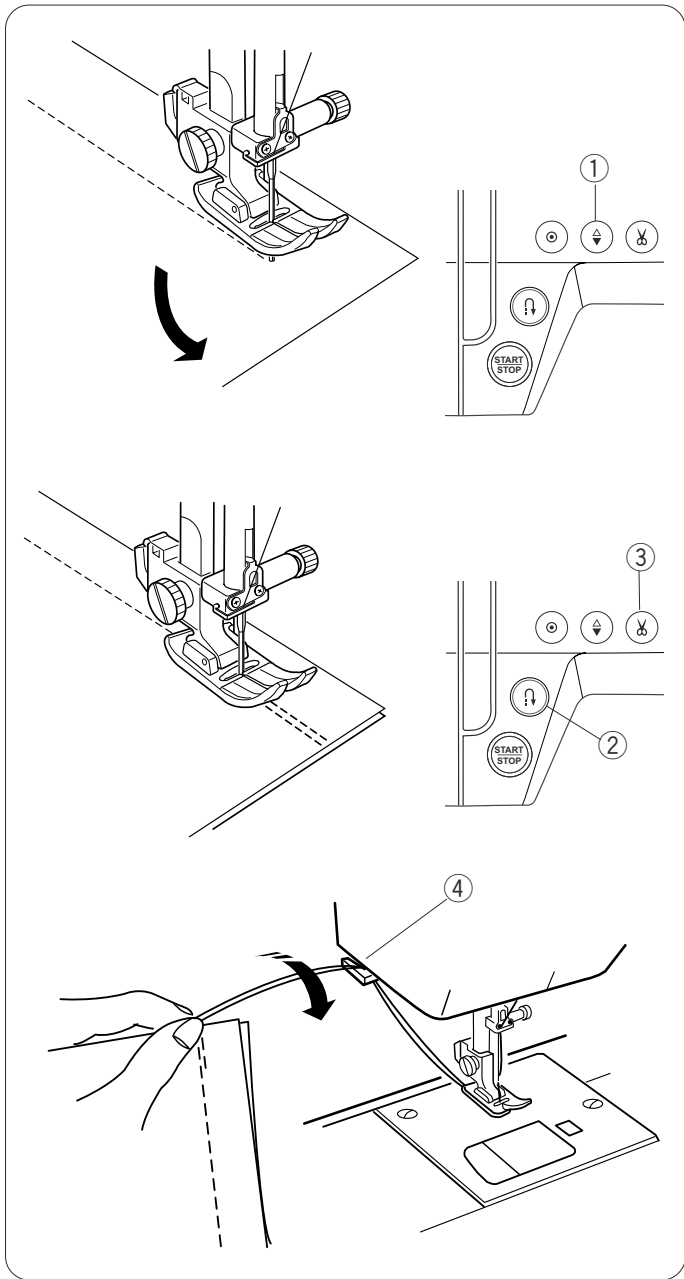

Changing sewing direction

Stop the machine and raise the presser foot.

Pivot the fabric around the needle to change the sewing direction as desired.

Lower the foot and start sewing in a new direction.

NOTE:

The machine stops with the needle in down position when patterns 1 to 25 are selected.

Press the needle up/down button to lower the needle if the machine stops with the needle in up position.

- ① Needle up/down button

Securing seam

To secure the end of seam, press the reverse stitch button and sew several reverse stitches.

Press the thread cutter button to cut the threads.

- ② Reverse stitch button
- ③ Thread cutter button

Raise the presser foot.

Use the thread cutter on the face plate to cut thicker threads.

- ④ Thread cutter

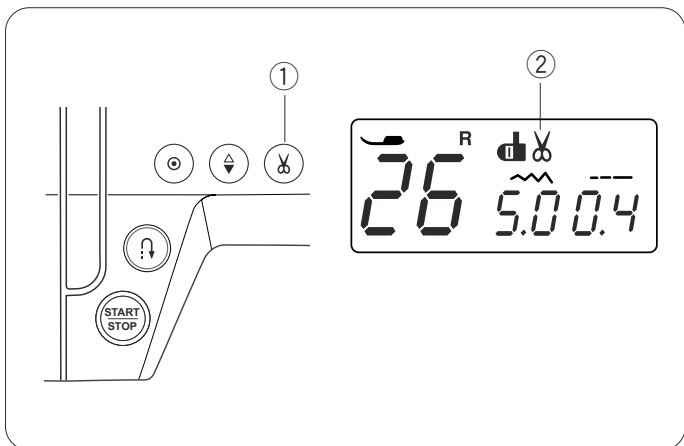

Auto Thread Cutting

To cut the threads automatically after locking stitches, press and hold the thread cutter button until the thread cutter icon appears on the LCD screen.

- ① Thread cutter button
- ② Thread cutter icon

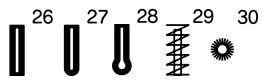
When buttonhole, tacking or eyelet  is selected, the machine will cut the threads automatically after sewing is finished.

Press the locking stitch button or reverse stitch button to cut the threads automatically after locking stitches when other stitch is selected.

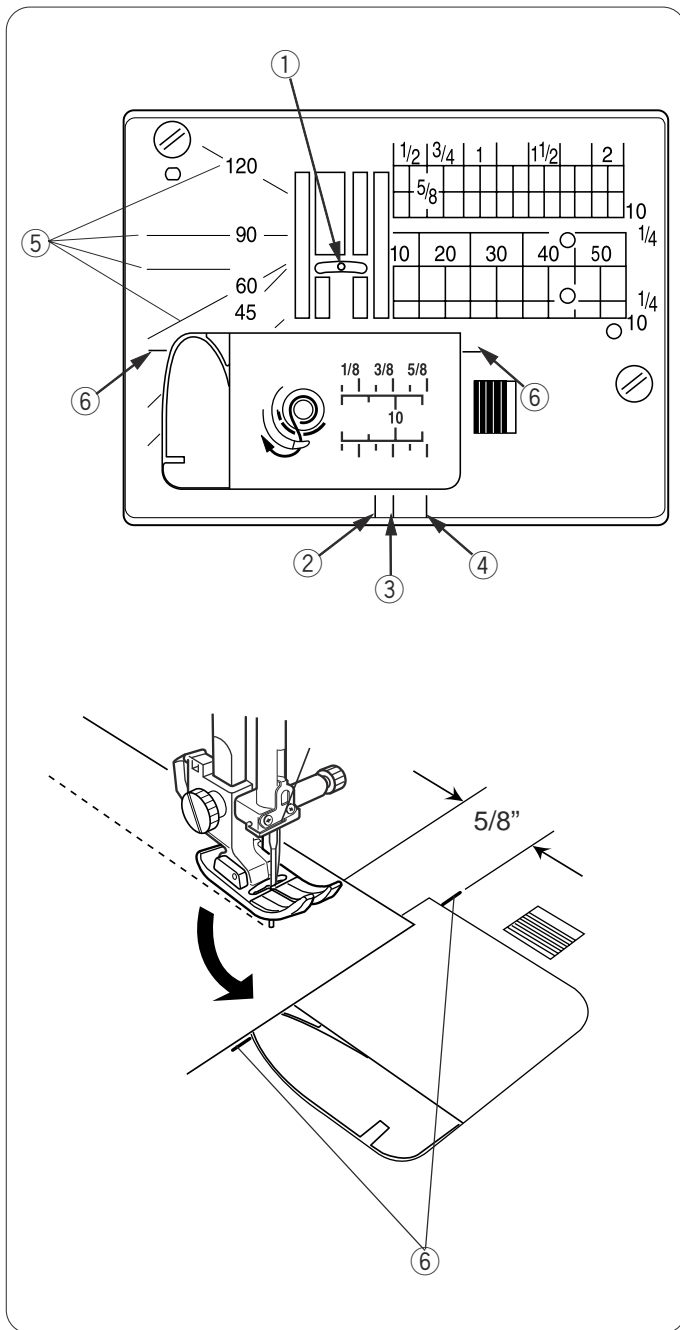

Using Seam Guides

The seam guides on the needle plate and the hook cover plate help you to measure seam allowance.

The numbers on the needle plate indicate the distance from the center needle position in inches and millimeters.

- ① Center needle position

The front seam guides are marked at 1/4", 3/8" and 5/8" from the center needle position.

- ② Front seam guide at 1/4"
- ③ Front seam guide at 3/8"
- ④ Front seam guide at 5/8"

The angle scales are marked at 45, 60, 90 and 120 degrees.

Use the angle scales when seaming patchwork pieces (refer to page 40).

- ⑤ Angle scales

Turning a square corner

To maintain a 5/8" seam allowance after turning a square corner, use the cornering guide on the needle plate.

- ⑥ Cornering guides

Stop sewing when the front edge of fabric reaches the cornering guides.

Raise the presser foot and turn the fabric 90 degrees. Start sewing in a new direction.

Altering the needle drop position

The needle drop position can be altered for straight stitch patterns 01 to 05 and 19.

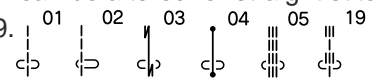

Press the “-” sign on the stitch width adjusting button to move the needle to the left.

Press the “+” sign on the stitch width adjusting button to move the needle to the right.

① Stitch width adjusting button

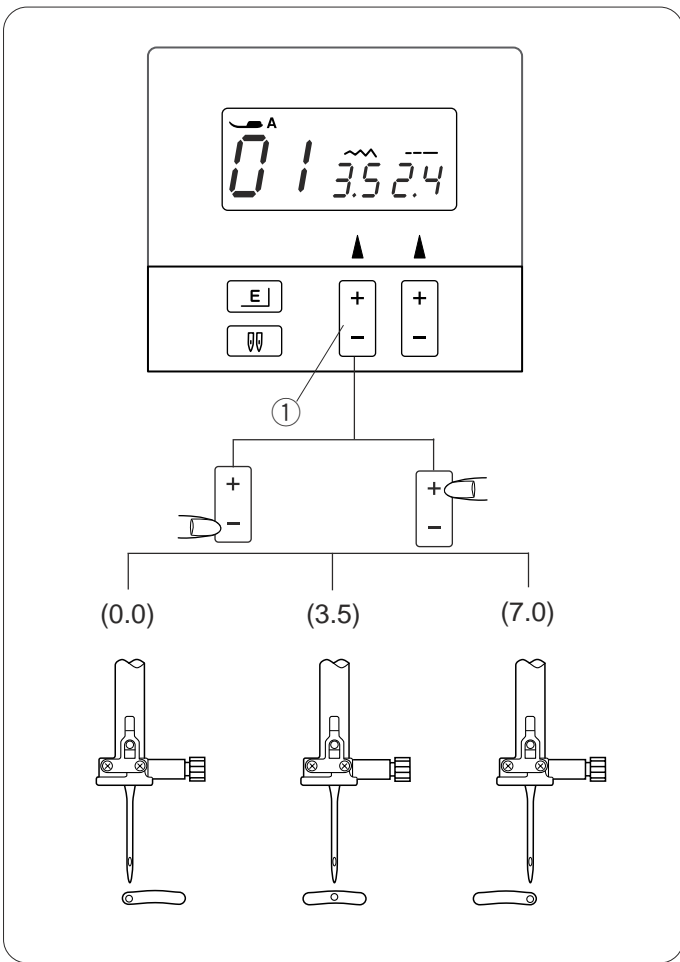

Altering the stitch length

The stitch length can be altered.

Press the “+” sign on the stitch length adjusting button to increase the stitch length.

Press the “-” sign on the stitch length adjusting button to decrease the stitch length.

② Stitch length adjusting button

NOTE:

Reverse stitch length cannot be set longer than 4.0.

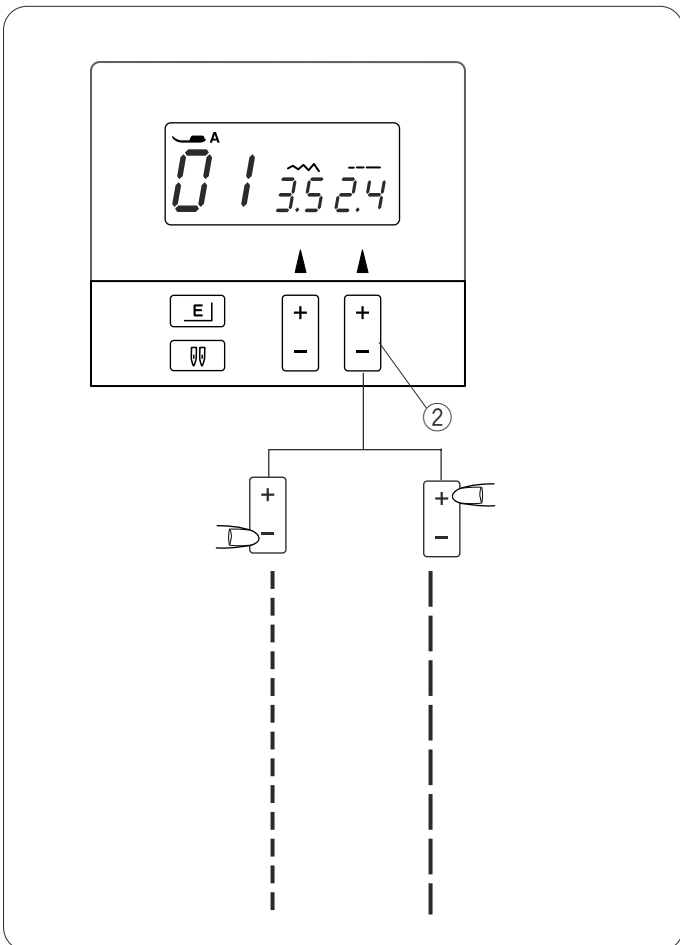

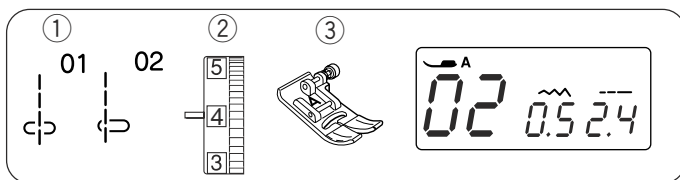

Straight stitch

- ① Stitch pattern: 01 or 02
- ② Needle thread tension: 2 to 6
- ③ Presser foot: Zigzag foot A

For seaming garments, zipper application and more. Pattern 02 is used for seaming fine fabrics.

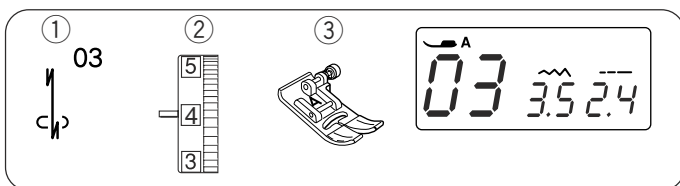
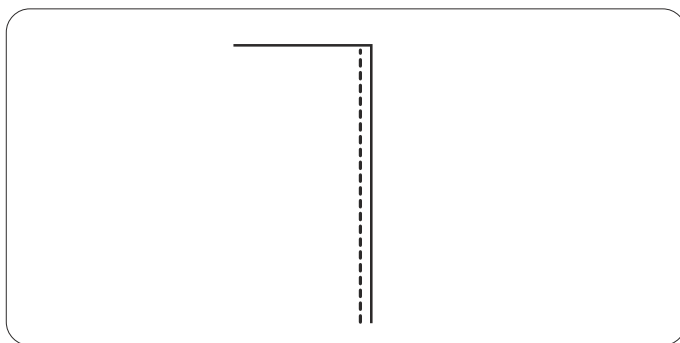

Lock-a-matic stitch

- ① Stitch pattern: 03
- ② Needle thread tension: 2 to 6
- ③ Presser foot: Zigzag foot A

Use this stitch to secure the beginning and the end of a seam with backstitching. When you reach the end of the seam, press the reverse stitch button once. The machine will sew four reverse stitches, four forward stitches, and then stop sewing automatically.

- ④ Reverse button

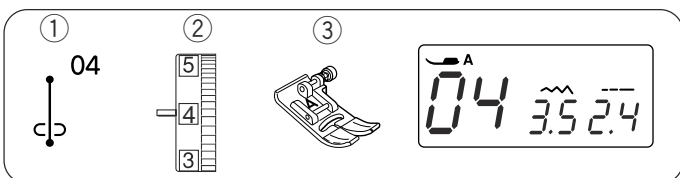
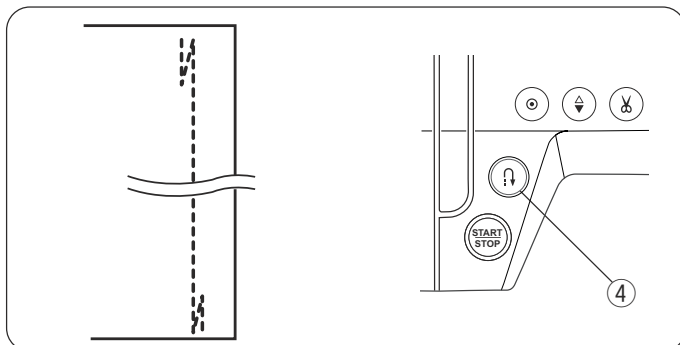

Locking stitch

- ① Stitch pattern: 04
- ② Needle thread tension: 2 to 6
- ③ Presser foot: Zigzag foot A

This unique stitch is used where an invisible locking stitch is needed.

Lower the needle close to the front edge of the fabric. The machine will sew several locking stitches in place and continue sewing forward. When you press the reverse stitch button at the end of the seam, the machine will sew several locking stitches in place, then stop sewing automatically.

- ④ Reverse button

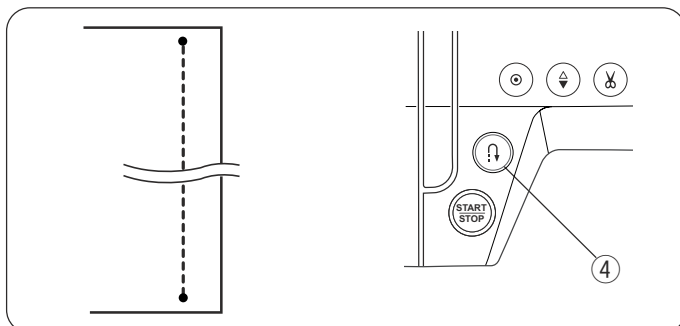

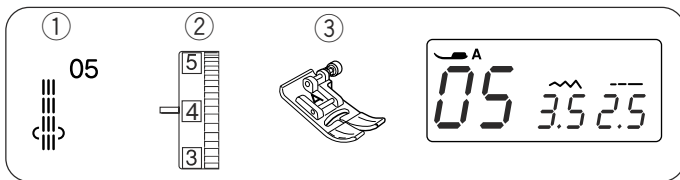

Triple stretch stitch

- ① Stitch pattern: 05
- ② Needle thread tension: 2 to 6
- ③ Presser foot: Zigzag foot A

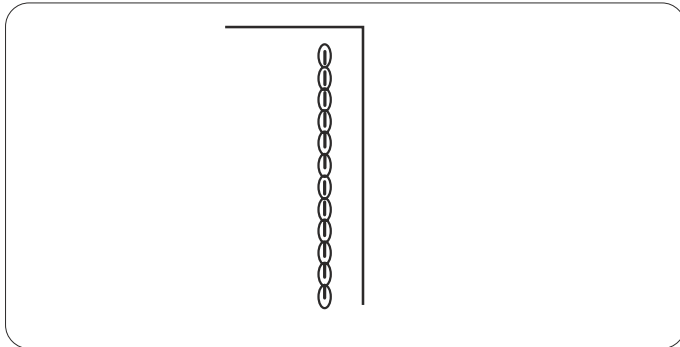

This strong, durable stitch is recommended when both elasticity and strength are necessary in order to insure comfort and durability. Use it to reinforce areas such as crotch and armhole seams. Also use for extra reinforcement when constructing items such as backpacks.

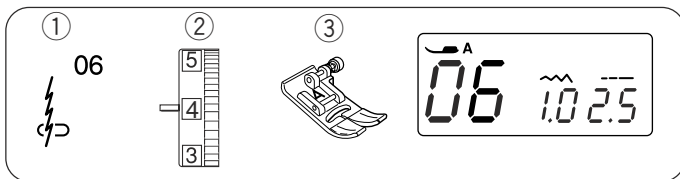

Stretch stitch

- ① Stitch pattern: 06
- ② Needle thread tension: 3 to 6
- ③ Presser foot: Zigzag foot A

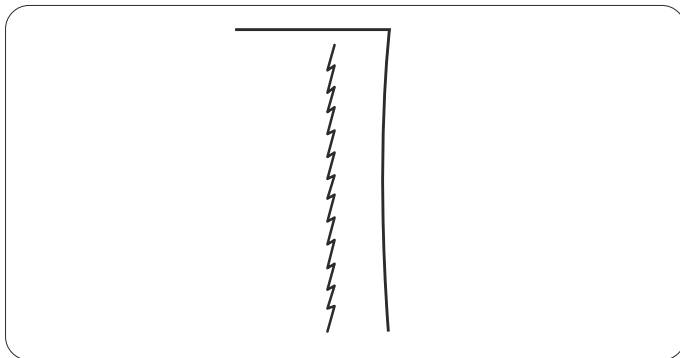

This stitch is a narrow stretch stitch designed to eliminate puckering on knit fabrics and bias seams, while permitting the seam to be pressed completely open flat. Use this stitch for seaming fine fabrics.

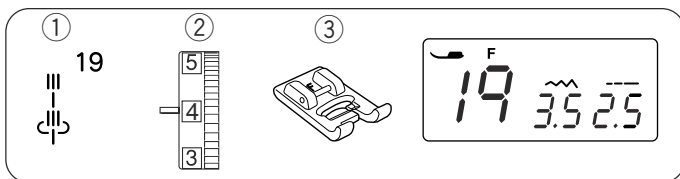

Saddle stitch

- ① Stitch pattern: 19
- ② Needle thread tension: 3 to 6
- ③ Presser foot: Satin stitch foot F

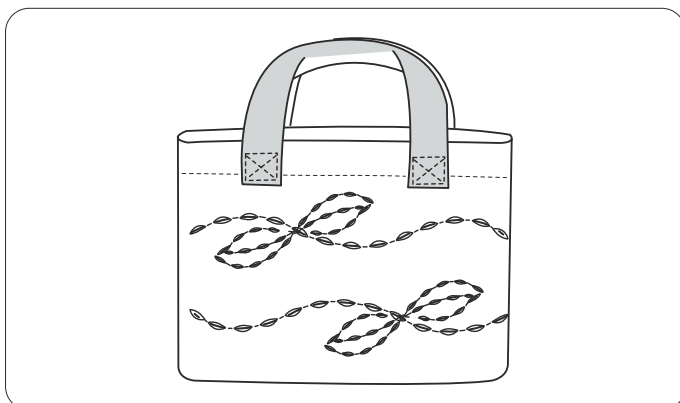

The saddle stitch is formed with one stitch forward, two stitches backward, and a fourth stitch forward. You can achieve a lovely hand-worked look when topstitching suits, blazers, jumpers, and denim outfits with the saddle stitch.

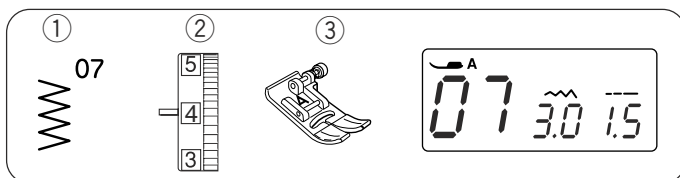

Zigzag Stitches

- ① Stitch pattern: 07
- ② Needle thread tension: 2 to 6
- ③ Presser foot: Zigzag foot A

The zigzag stitch is one of the most useful and versatile stitches.

It is used for overcasting, mending, appliqué, and also used as a decorative stitch.

NOTE:

Use interfacing when sewing on stretch fabrics such as knit, jersey or tricot.

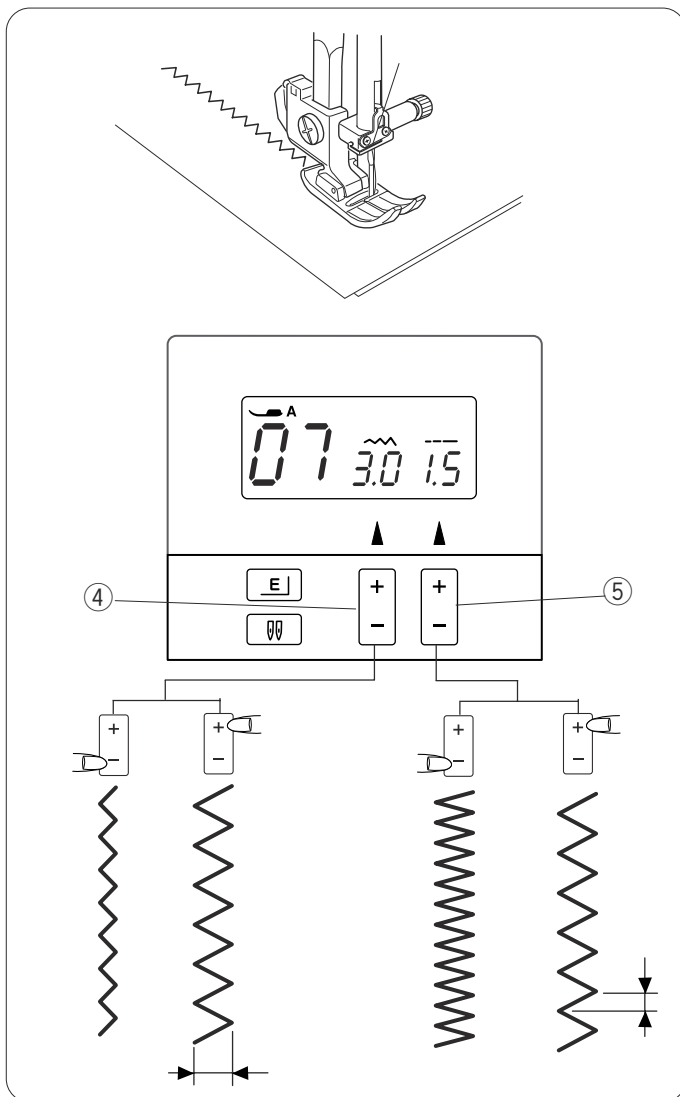

Altering the stitch width

Press the “+” sign on the stitch width adjusting button to increase the stitch width.

Press the “-” sign on the stitch width adjusting button to decrease the stitch width.

- ④ Stitch width adjusting button

Altering the stitch length

Press the “+” sign on the stitch length adjusting button to increase the stitch length.

Press the “-” sign on the stitch length adjusting button to decrease the stitch length.

- ⑤ Stitch length adjusting button

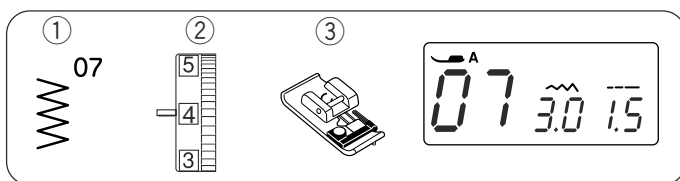

Overcasting with zigzag stitch

- ① Stitch pattern: 07
- ② Needle thread tension: 3 to 7
- ③ Presser foot: Overedge foot C

Place the fabric edge next to the guide on the foot and sew while guiding the fabric along the guide.

- ④ Guide

CAUTION:

When using an overedge foot, make sure to set the stitch width at 4.5 or wider, otherwise the needle may hit the wires on the foot.

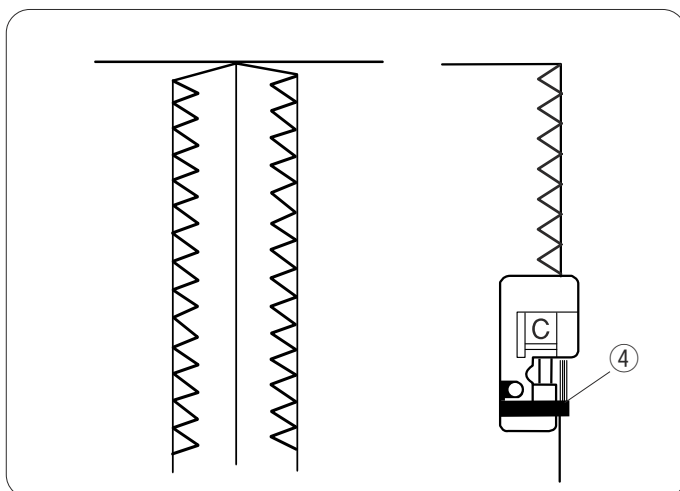

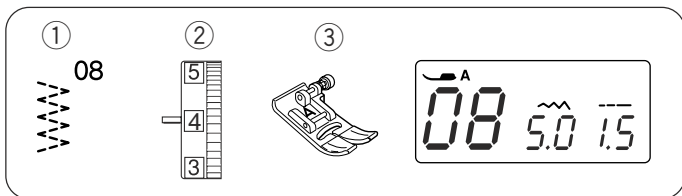

Multiple zigzag stitch

- ① Stitch pattern: 08
- ② Thread tension dial: 3 to 7
- ③ Presser foot: Zigzag foot A

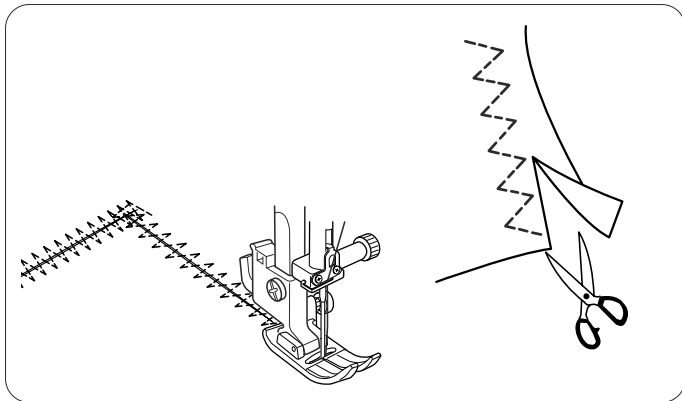

This stitch is used to finish a raw edge of synthetics and other stretch fabrics that tend to pucker.

Sew along the fabric edge leaving an adequate seam allowance.

After sewing, trim off the seam allowance closer to the stitches.

This stitch is also excellent for darning and mending tears.

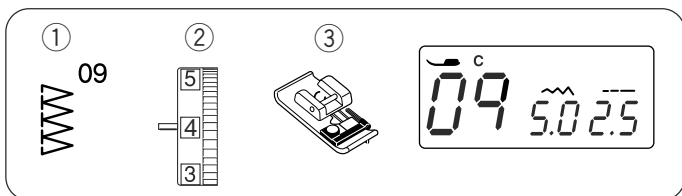

Overedge stitch

- ① Stitch pattern: 09
- ② Thread tension dial: 3 to 7
- ③ Presser foot: Overedge foot C

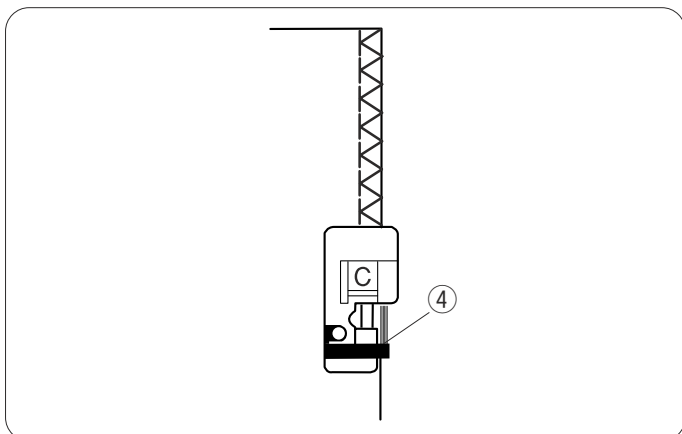

This stitch is used to seam and overcast fabric edges at one time.

Use this stitch when you do not need to open seams flat. Sew while guiding the fabric edges along the guide on the foot.

- ④ Guide

NOTE:

The stitch width cannot be adjusted to less than 4.5 to prevent the needle from hitting the wires on the foot.

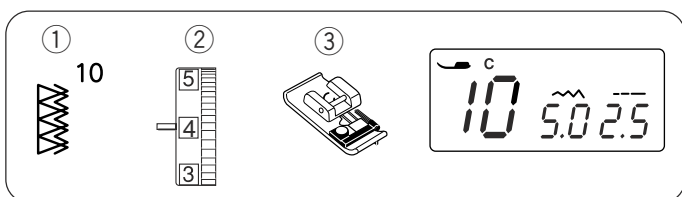

Double overedge stitch

- ① Stitch pattern: 10
- ② Thread tension dial: 3 to 7
- ③ Presser foot: Overedge foot C

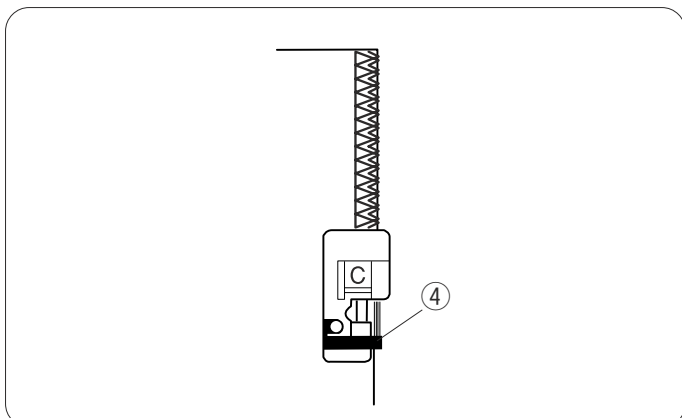

This stitch is excellent for sewing fabrics that tend to fray extensively such as linens and gabardines.

Two rows of zigzag stitches are simultaneously sewn over the edge to insure that your seams will not ravel. Sew while guiding the fabric edges along the guide on the foot.

- ④ Guide

NOTE:

The stitch width cannot be adjusted to less than 4.5 to prevent the needle from hitting the wires on the foot.

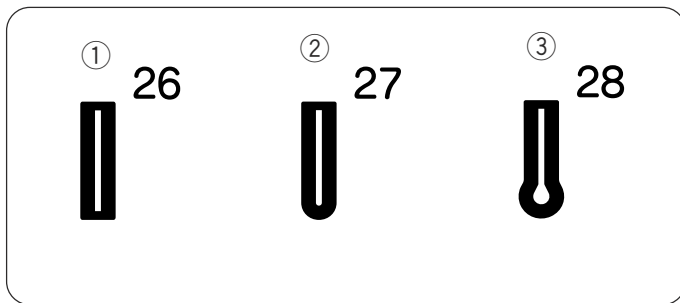

Buttonholes

The following 3 types of buttonholes are available.

① Square Buttonhole

This buttonhole is widely used on medium to heavy fabrics. The buttonhole size is automatically determined by placing a button in the foot.

② Round-end Buttonhole

This buttonhole is used on fine to medium weight fabrics, especially for blouses and children's clothes.

③ Keyhole Buttonhole

The keyhole buttonhole is widely used on medium to heavy fabrics. It is also suitable for larger and thicker buttons.

NOTES:

- To sew buttonholes 27 and 28, follow the same procedure as buttonhole 26.
- The buttonhole size is automatically set by placing a button in the rear of automatic buttonhole foot R.
- The button holder of the foot takes a button size of up to 1" (2.5 cm) in diameter.
- It is sometimes necessary to change buttonhole size to match certain heavy or specific materials and threads.
- Make a test buttonhole on an extra piece of the fabric to check your setting.
- Place the button on the fabric and mark the top and bottom to determine the position of the buttonhole on the fabric.
- Use interfacing on stretch fabrics.

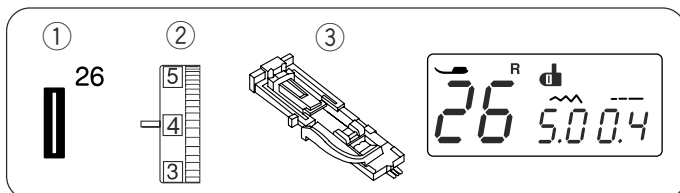

Square buttonhole

- | | |
|------------------------|-----------------------------|
| ① Stitch pattern: | 26 |
| ② Thread tension dial: | 1 to 5 |
| ③ Presser foot: | Automatic buttonhole foot R |

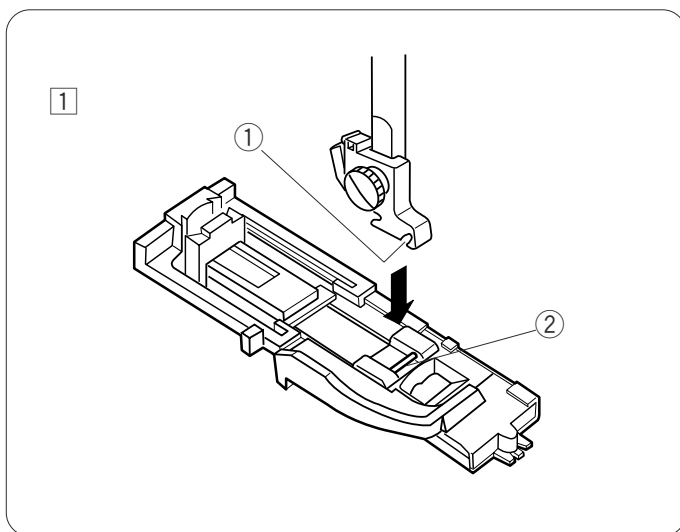

To sew

- 1 Attach the automatic buttonhole foot R by snapping the pin into the groove of the foot holder.
 - ① Groove
 - ② Pin

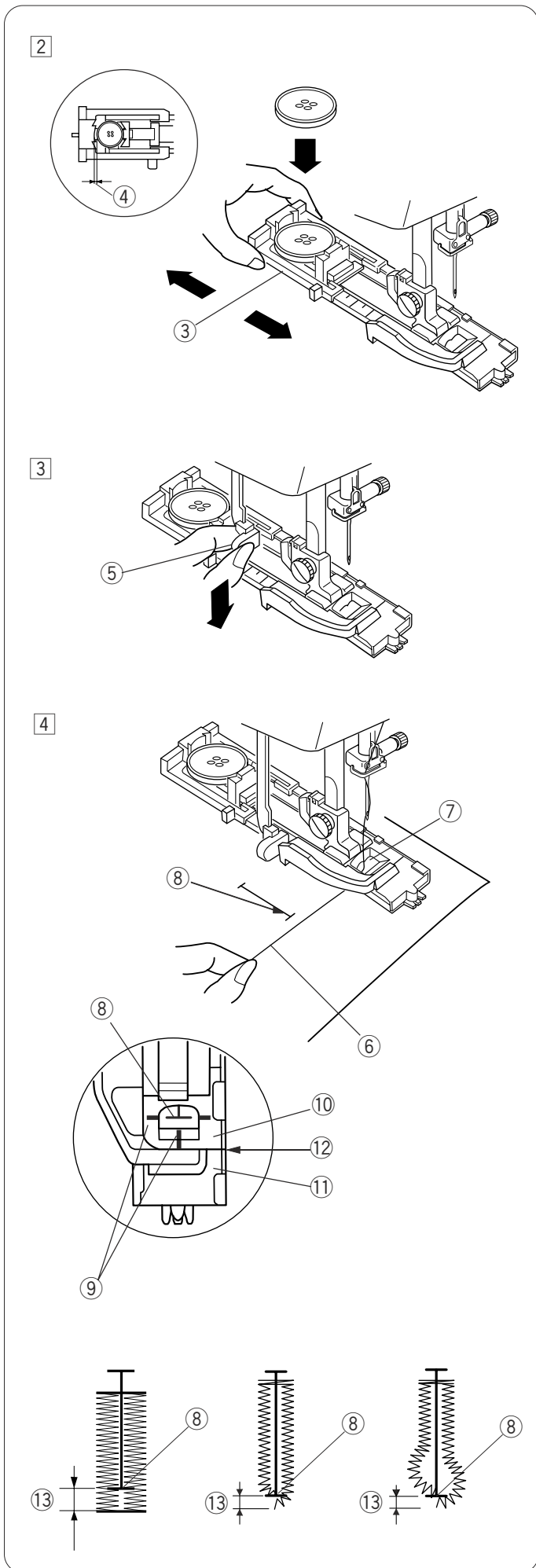

- 2 Pull the button holder to the back, and place the button in it. Push it together tightly to the button.
- 3 Button holder

NOTE:

If the button is extremely thick, make a test buttonhole on an extra piece of the fabric.

If it is difficult to fit the button through the test buttonhole, you can lengthen the buttonhole by pulling the button holder back a little. The length of the buttonhole will be increased.

- 4 Extra gap

- 3 Pull the buttonhole lever down as far as it will go.
- 5 Buttonhole Lever

- 4 Draw the needle thread to the left through the hole of the foot. Mark the buttonhole position on the fabric. Position the fabric and lower the needle into the starting point. Lower the buttonhole foot. Start sewing while pulling the needle thread lightly to the left. After several stitches, free the needle thread and continue sewing.

- 6 Needle thread
- 7 Hole
- 8 Starting point

NOTES:

The reference marks on the buttonhole foot can be used as a positioning guide.

Make sure there is no gap between the slider and stopper, otherwise the buttonhole will not be sewn in the required position.

- 9 Reference lines
- 10 Slider
- 11 Stopper
- 12 No gap
- 13 Sewing gap

Using the stabilizer plate

The stabilizer plate holds and supports fabrics so it is helpful when sewing buttonholes over the hem of thick fabrics.

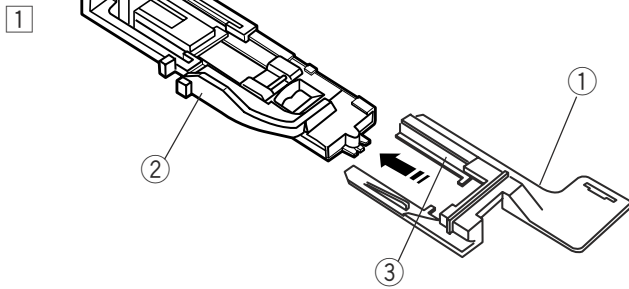

- 1 Attach the stabilizer holder to the buttonhole foot by inserting the foot into the channels of the holder.

- 1 Stabilizer plate holder
- 2 Buttonhole foot
- 3 Channel

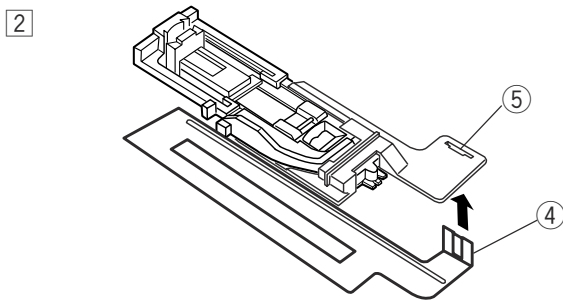

- 2 Insert the tab of the stabilizer plate into the slot of the plate holder.

- 4 Tab
- 5 Slot

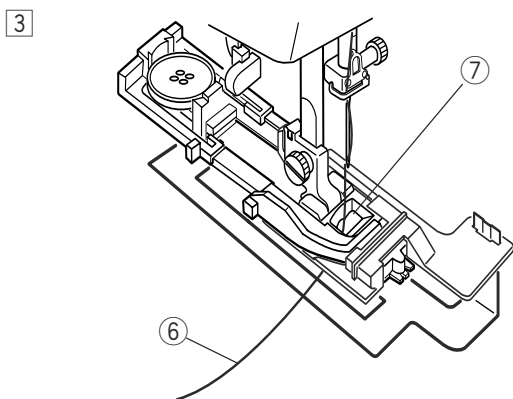

- 3 Attach the buttonhole foot with the stabilizer plate to the machine.

Pass the needle thread through the hole of the foot and draw it to the left between the foot and stabilizer plate.

- 6 Needle thread
- 7 Hole of the foot

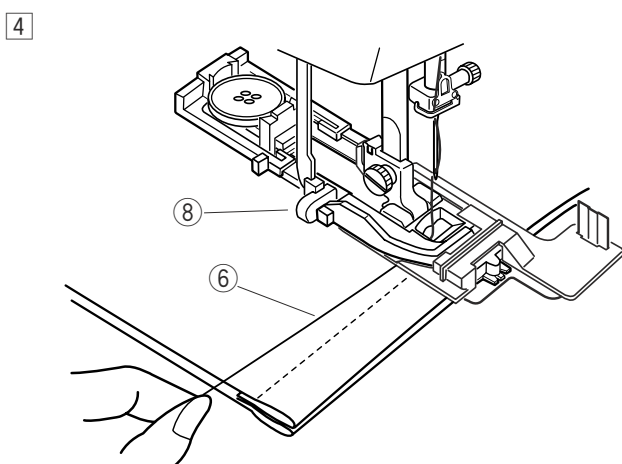

- 4 Insert the fabric between the foot and stabilizer plate. Position the fabric and lower the needle into the starting point.

Lower the foot and pull down the buttonhole lever as far as it will go.

Start sewing while pulling the needle thread lightly to the left. After several stitches, free the needle thread and continue sewing.

- 8 Buttonhole lever

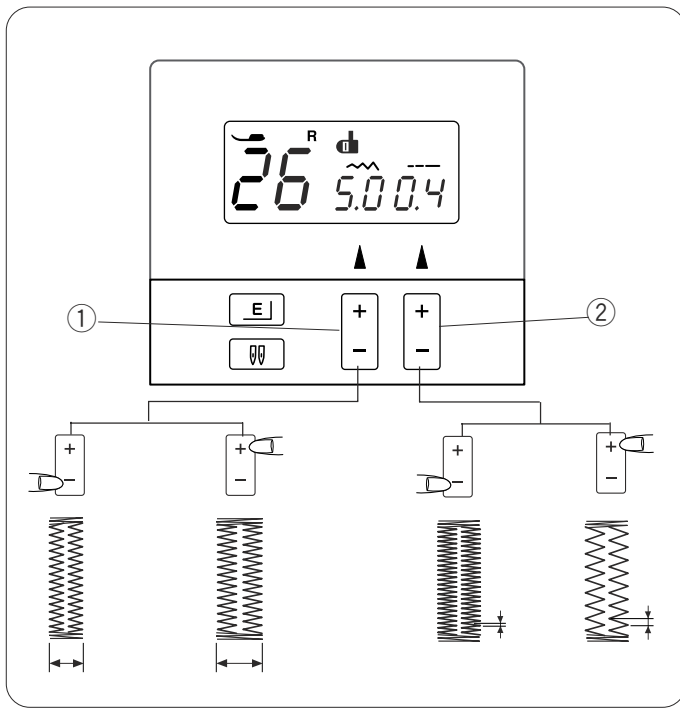

Adjusting the width and density for buttonholes

• Adjusting the buttonhole width

Press the “+” sign on the stitch width adjusting button to increase the buttonhole width.

Press the “-” sign on the stitch width adjusting button to decrease the buttonhole width.

① Stitch width adjusting button

NOTE:

The buttonhole width can be adjusted from 2.5 to 7.0.

• Adjusting the stitch density

Press the “+” sign on the stitch length adjusting button to increase the stitch density.

Press the “-” sign on the stitch length adjusting button to decrease the stitch density.

② Stitch length adjusting button

NOTE:

The buttonhole width can be adjusted from 0.3 to 0.8.

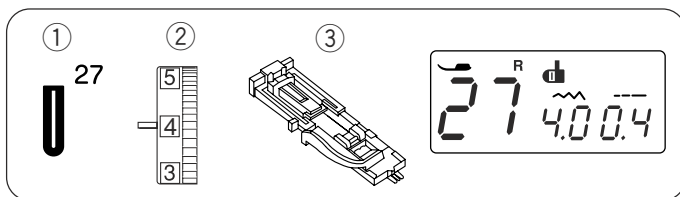

Round-end buttonhole

- ① Stitch pattern: 27
- ② Thread tension dial: 1 to 5
- ③ Presser foot: Automatic buttonhole foot R

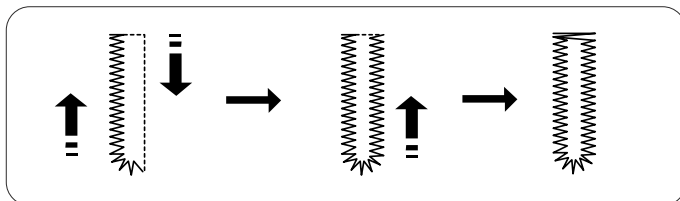

Sewing procedure is the same as square buttonhole.

The buttonhole width can be varied from 2.5 to 5.5.

The stitch density can be varied from 0.3 to 0.8.

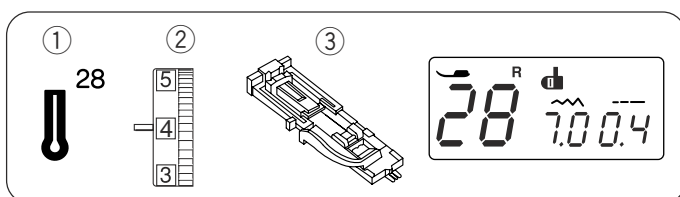

Keyhole buttonhole

- ① Stitch pattern: 28
- ② Thread tension dial: 1 to 5
- ③ Presser foot: Automatic buttonhole foot R

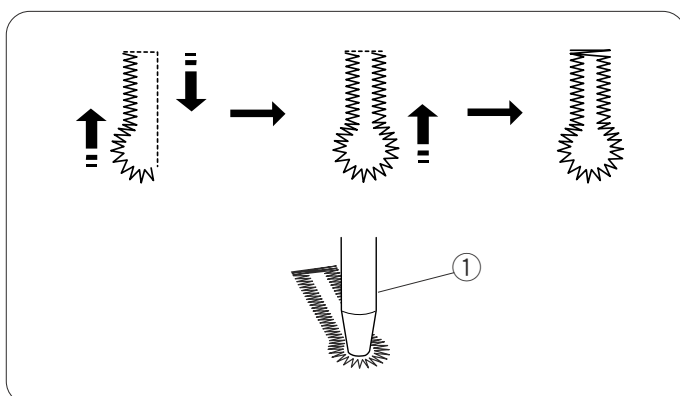

Sewing procedure is the same as square buttonhole.

The buttonhole width can be varied from 5.5 to 7.0.

The stitch density can be varied from 0.3 to 0.8.

Use the seam ripper and an eyelet punch to open the buttonhole.

① Eyelet punch (not provided with the machine)

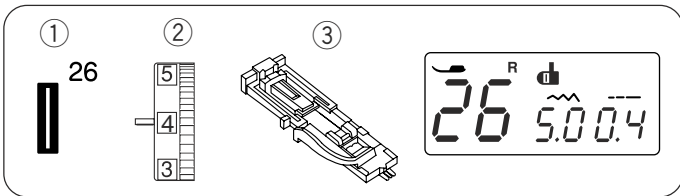

Corded buttonhole

- ① Stitch pattern: 26
- ② Thread tension dial: 1 to 5
- ③ Presser foot: Automatic buttonhole foot R

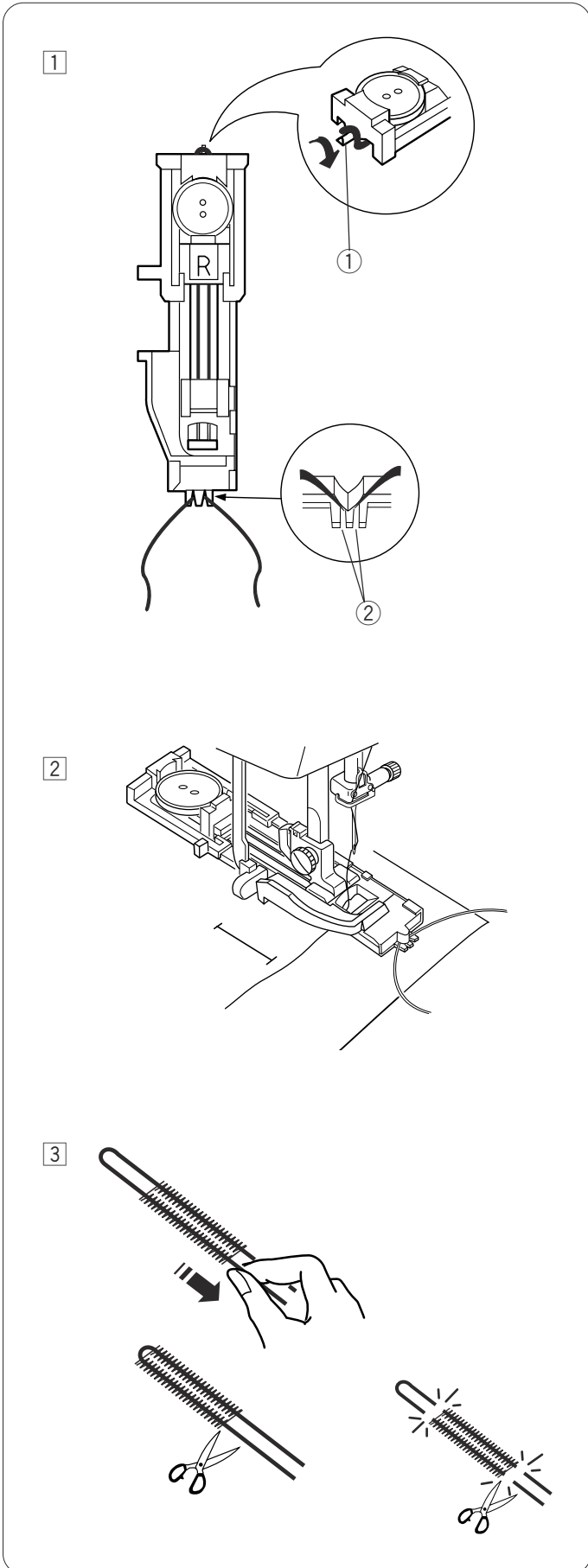

- ① Use the same procedure as the square buttonhole sewing.
 Set the stitch width to match the thickness of the cord used.
 With the buttonhole foot raised, hook the filler cord on the spur at the back of the buttonhole foot.
 Bring the ends toward you under the buttonhole foot, clearing the front end.
 Hook the filler cord into the forks on the front of the buttonhole foot to hold them tight.
 Lower the needle into the garment where the buttonhole will start, and lower the foot.

- ① Spur
- ② Forks

- ② Start the machine and sew the buttonhole.
 Each side of the buttonhole and the bartacks will be sewn over the cord.
 Remove the fabric from the machine, and cut the sewing threads only.

- ③ Pull the loose ends of the filler cord to tighten it.
 Cut the both ends of the filler cord.

NOTE:

Cut the filler cord at both ends, if the filler cord is stitched on the fabric and cannot be pulled.

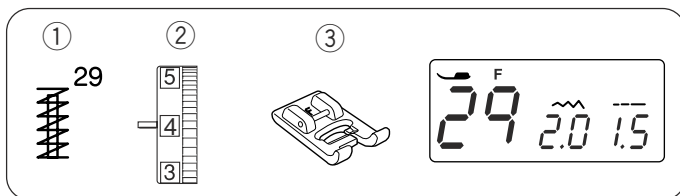

Tacking

- ① Stitch pattern: 29
- ② Thread tension dial: 3 to 6
- ③ Presser foot: Satin stitch foot F

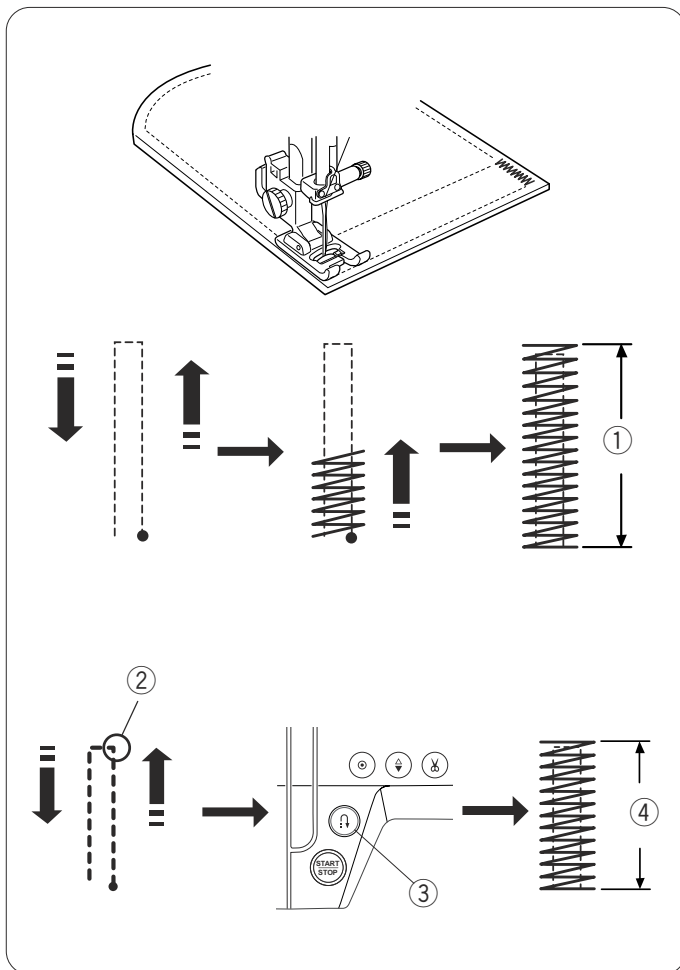

Tacking is used to reinforce pockets, crotches and belt carriers where extra strength is needed.

• Start sewing

Start the machine and sew until the machine stops automatically. The machine will sew a tacking 1.5 cm (5/8") long.

- ① 1.5 cm (5/8")

NOTE:

The machine will cut the threads at the end of sewing automatically if the thread cutter icon is indicated on the LCD display (refer to page 20).

• Sewing a shorter tack

To sew a tack shorter than 1.5 cm (5/8"), first stop the machine after sewing the required length, then press the reverse stitch button.

The tack length has been determined.

Start the machine again and continue sewing until the machine stops automatically.

- ② Required length
- ③ Reverse stitch button
- ④ Tack length

• Sewing a same-size tacking

Simply start the machine to sew another tack at the same size.

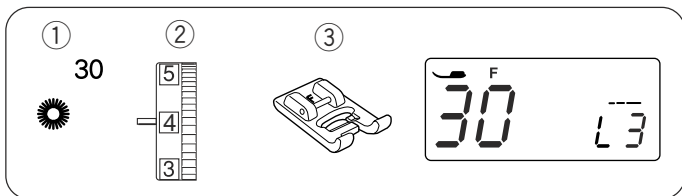

Eyelet

- ① Stitch pattern: 30
- ② Needle thread tension: 1 to 4
- ③ Presser foot: Satin stitch foot F

The eyelet is used for belt holes etc.

• Starting to sew

Lower the needle at the starting point and lower the presser foot. Start the machine.

The machine will stop automatically when completed.

- ① Starting point

Open the eyelet with an awl, eyelet punch or pointed scissors.

NOTE:

The machine will cut the threads at the end of sewing automatically if the thread cutter sign is indicated on the LCD display (refer to page 20).

• Adjusting the shape of an eyelet

Correct the shape of the eyelet as follows:

If the eyelet gap opens, press the “-” on the stitch length adjusting button to make the darn even. (L1~L2)

If the eyelet overlaps, press the “+” on the stitch length adjusting button to make the darn even. (L4~L5)

- ② Stitch length adjusting button

NOTE:

The shape can be adjusted within L1 to L5 (default setting is L3).

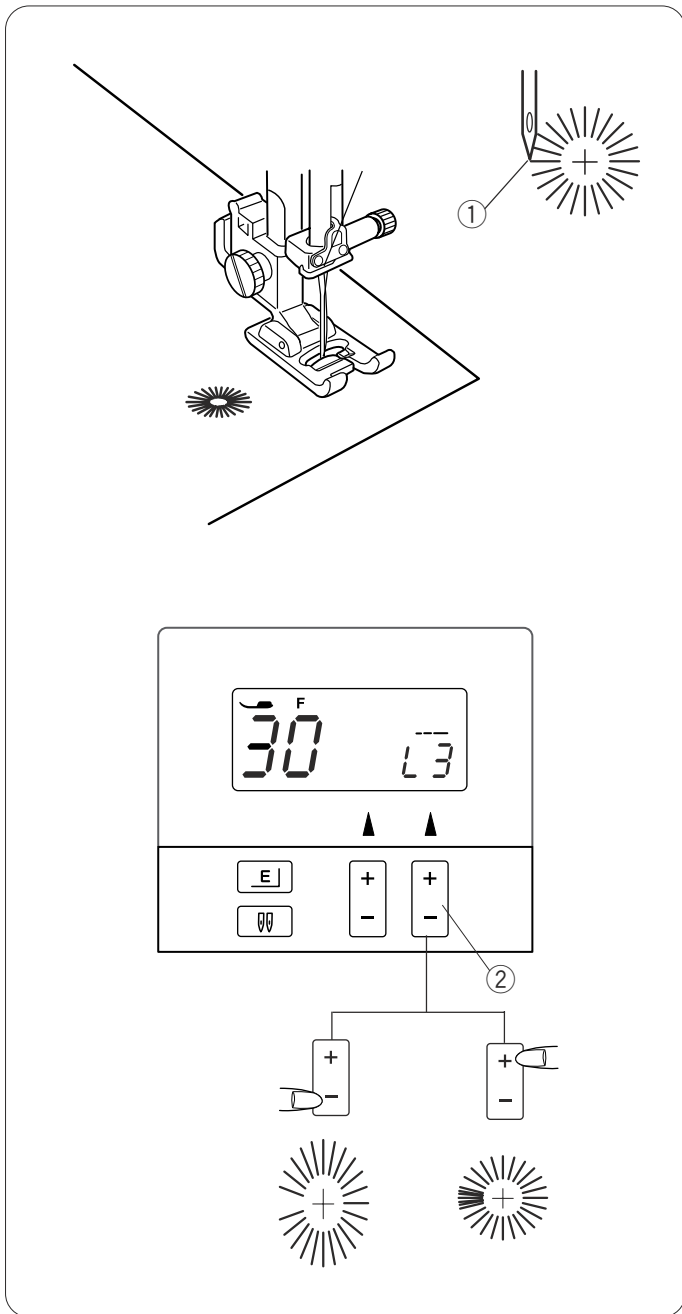

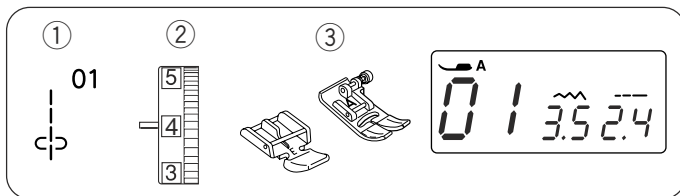

Zipper Sewing

- ① Stitch pattern: 01
- ② Needle thread tension: 1 to 4
- ③ Presser foot: Zigzag foot A
Zipper foot E

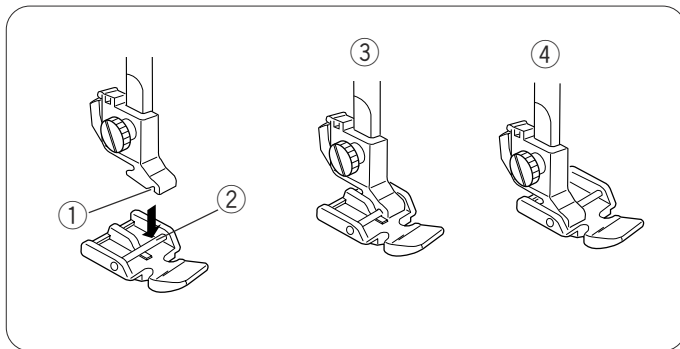

Attaching the zipper foot

Fit the pin on the zipper foot into the groove of the foot holder.

To sew the left side of the zipper, attach zipper foot with the right-hand side of pin.

To sew the right-side of zipper, attach zipper foot with the left-hand side of pin.

- ① Groove
- ② Pin
- ③ To sew left side
- ④ To sew right side

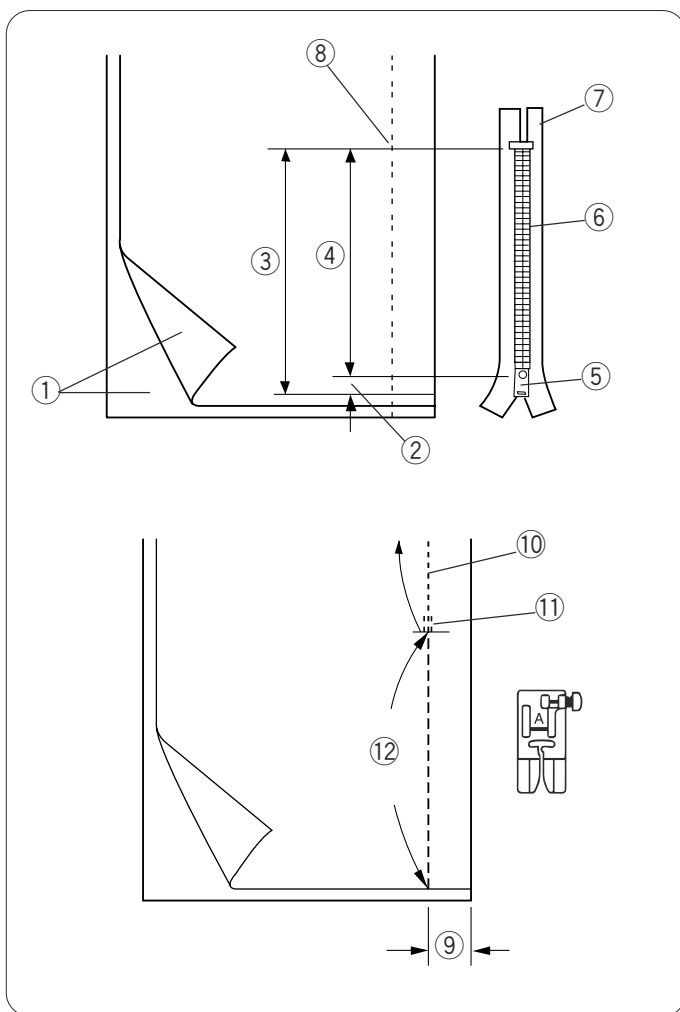

Fabric preparation

Add 1 cm (3/8") to the zipper length. This is the overall opening size.

- ① Right side of the fabric
- ② 1 cm (3/8")
- ③ Opening size
- ④ Zipper length
- ⑤ Slider
- ⑥ Zipper teeth
- ⑦ Zipper tape
- ⑧ End of the opening

Place the right sides of the fabric together.

Attach the zigzag foot and seam up to the end of the zipper opening, with a 2 cm (13/16") seam allowance.

Reverse the stitch to fasten the seam.

Baste along the zipper opening with the stitch length 5.0.

- ⑨ 2 cm (13/16")
- ⑩ Seam
- ⑪ Reverse stitches
- ⑫ Zipper opening (Basting)

NOTE:

Loosen the thread tension to "1" for basting.

Start sewing

1 Fold up the upper seam allowance. Fold back the bottom seam allowance to form a 0.3 cm (1/8") fold. Place the zipper teeth next to the fold and pin the zipper tape to the zipper opening.

- ① Upper seam allowance
- ② Bottom seam allowance
- ③ 0.3 cm (1/8")
- ④ Zipper teeth
- ⑤ Fold
- ⑥ Zipper opening

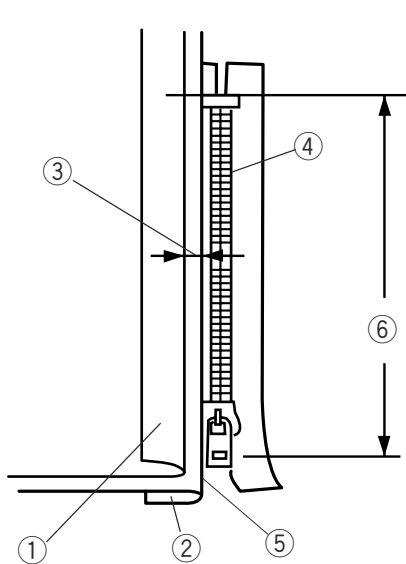

2 Attach the zipper foot with the pin on the right. Sew through all the layers from the end of the zipper opening, guiding the zipper teeth along the edge of the foot.

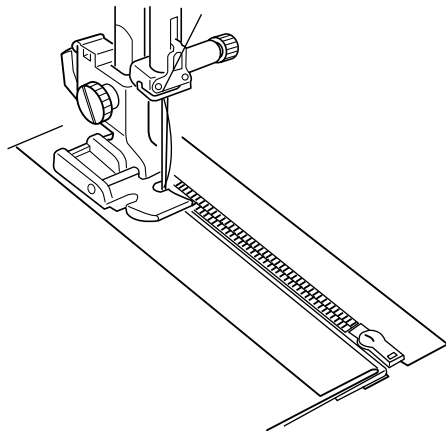

3 Stop the machine 5 cm (2") before the foot reaches the slider on the zipper tape. Lower the needle into the fabric, and raise the foot. Open the zipper, then lower the foot and stitch the remainder of the seam.

- ⑦ Slider
- ⑧ 5 cm (2")

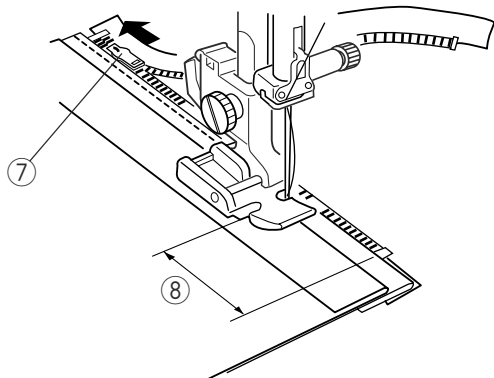

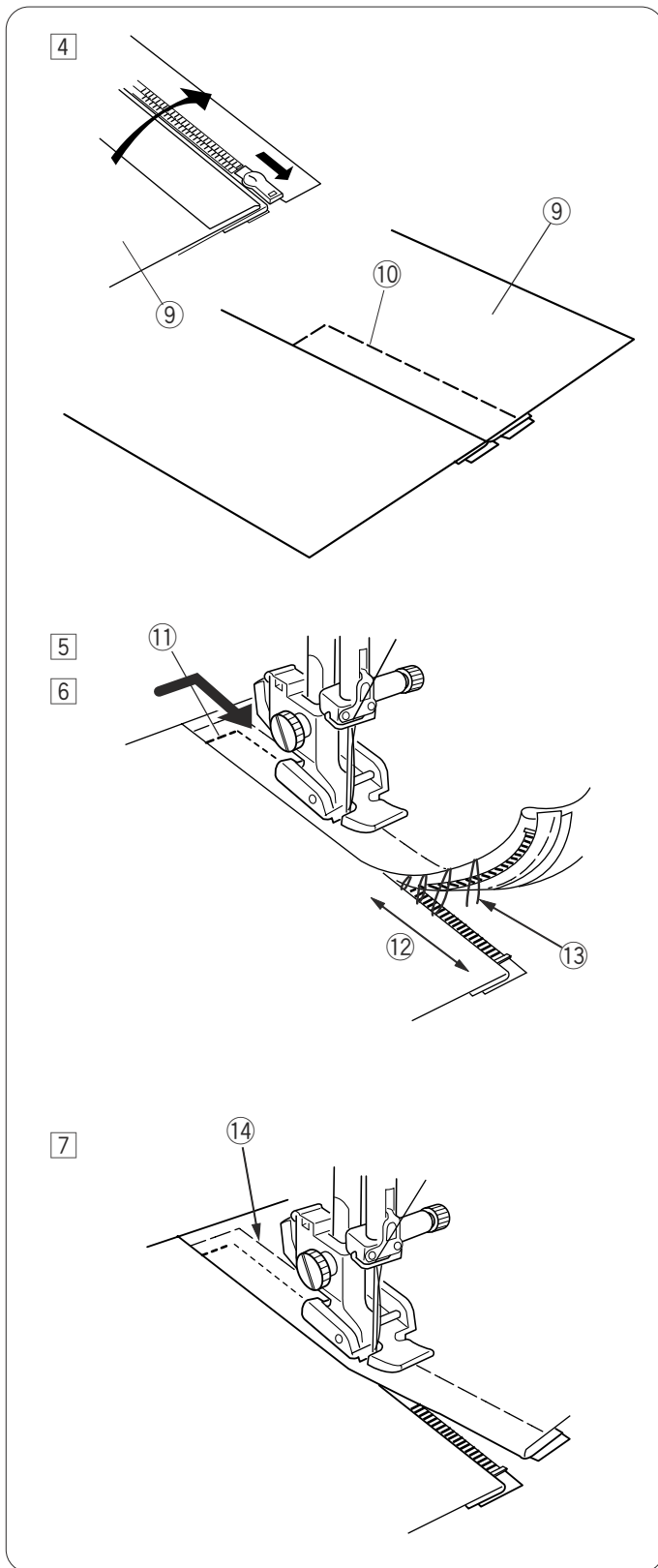

- 4 Close the zipper and open the upper fabric flat over the zipper.
 Baste the upper fabric and zipper tape together.
 9 Upper fabric
 10 Basting stitch
- 5 Detach the foot and attach it with the pin on the left.
 Backstitch across the end of opening 1 cm (3/8").
 Turn the fabric 90 degrees and stitch through the garment and zipper tape.
 11 Backstitch
- 6 Stop the machine 5 cm (2") before the foot reaches the slider on the zipper tape. Lower the needle into the fabric, and raise the foot. Remove the basting stitches.
 12 5 cm (2")
 13 Basting stitches
- 7 Open the zipper, then lower the foot and stitch the remainder of the seam.
 After sewing is finished, remove the basting stitches on the upper fabric.
 14 Basting stitches on upper fabric

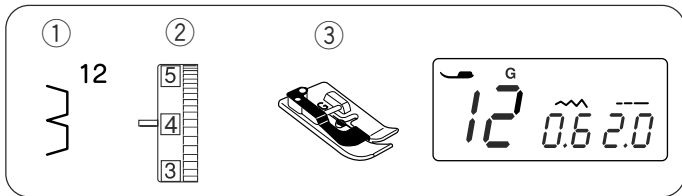

Blind Hemming

- ① Stitch pattern: 12
- ② Thread tension dial: 1 to 4
- ③ Presser foot: Blind Hem stitch foot G

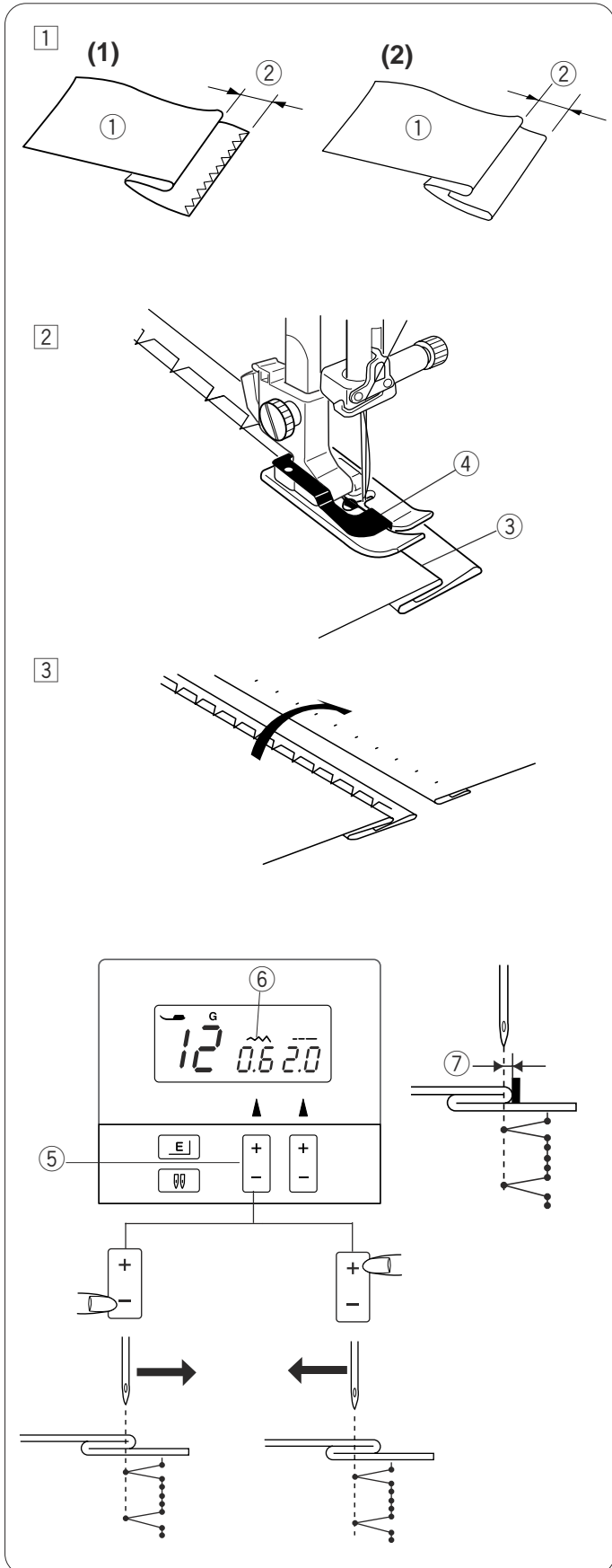

① Fold a hem with the wrong side of the fabric up to form a 0.5 cm (1/4") allowance.

① Wrong side of fabric

② 0.5 cm (1/4")

(1) On heavyweight fabrics that tend to ravel, the raw edge should be overcast first.

(2) Fold the hem under the fabric for lightweight fabrics.

② Place the fabric so that the fold is next to the guide on the foot. Lower the presser foot. Adjust the needle drop position if necessary. Sew while guiding the fold along the guide.

③ Fold

④ Guide

③ Open the fabric after sewing is finished.

NOTE:

If the needle pierces too far left, the stitch will show through on the right side of the fabric.

Adjusting the needle drop position

Press the “-” sign on the stitch width adjusting button to move the needle to the right.

Press the “+” sign on the stitch width adjusting button to move the needle to the left.

⑤ Stitch width adjusting button

The LCD display shows the left needle drop position from the guide in millimeters.

The needle drop position can be varied from 0.0 to 1.2.

⑥ LCD display

⑦ Left needle drop position from guide

NOTE:

The needle drop position can be moved, but the stitch width will remain the same.

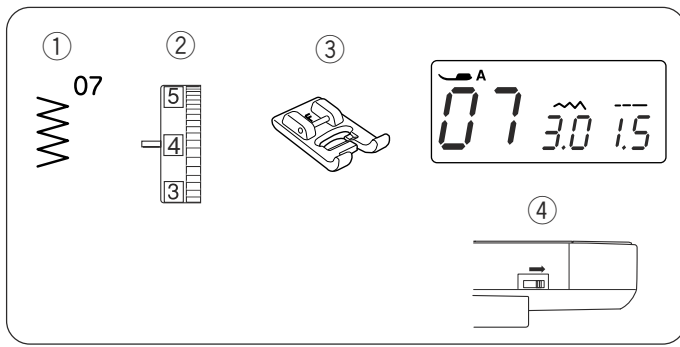

Button Sewing

- ① Stitch pattern: 07
- ② Needle thread tension: 3 to 7
- ③ Presser foot: Satin stitch foot F
- ④ Feed dog: Lowered

Lower the feed dog.
 Set the speed control slider at a slower speed.
 Set the stitch length at the minimum (0.2).

- ① Stitch length (0.2)

Match the holes of button to the horizontal slot of the presser foot and lower the foot to hold the button in place.

Adjust the stitch width so the needle will enter the left hole of the button.

Turn the handwheel so that the needle will enter the right hole of the button. Readjust the stitch width if necessary.

- ② Stitch width (adjust to span of holes)

Stitch several times.

After you finish sewing, cut the thread but leave 10 cm (4") of threads at the end.

With a hand sewing needle, draw the top thread to the reverse side of the fabric and knot the threads.

After the button sewing is completed, raise the feed dogs for normal sewing.

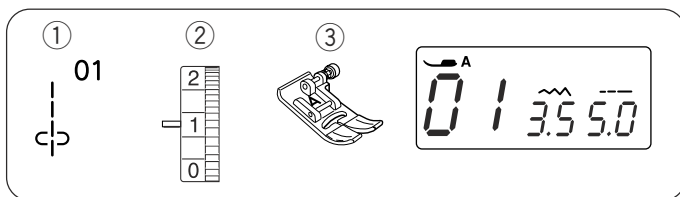
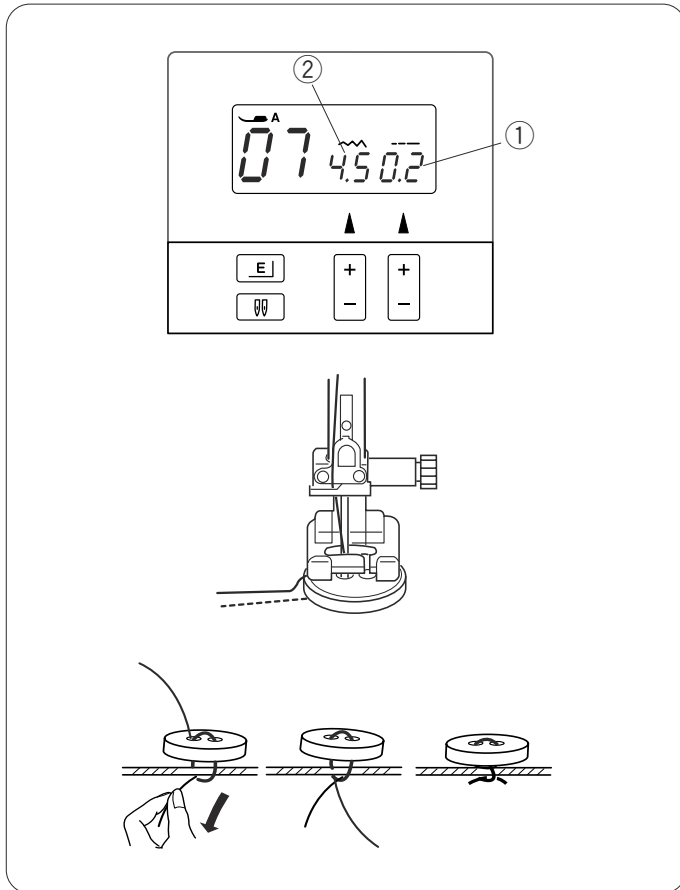

Gathering

- ① Stitch pattern: 01
- ② Needle thread tension: 1
- ③ Presser foot: Zigzag foot A

Loosen the thread tension to "1" and increase the stitch length to 5.0.

Sew two rows of straight stitches 0.6 cm (1/4") apart. Knot the threads at the beginning.

Pull the bobbin threads at the end to gather the fabric.

Knot the threads at the end and distribute the gathers evenly.

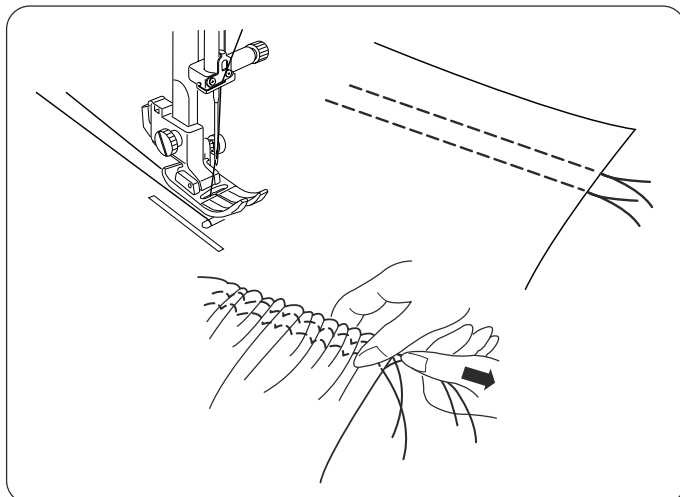

DECORATIVE STITCHING

Patchwork Piecing

- ① Stitch pattern: 01 or 04
- ② Thread tension dial: 3 to 6
- ③ Presser foot: 1/4" seam foot O

Put the patchwork pieces right sides together and place them on the needle plate.

Align the right edge of fabric with the guide of the 1/4" seam foot and angled edge with the relative angle scale; 45 degrees for Lemon Star piecing.

- ① Right edge of fabric
- ② Guide
- ③ Angled edge of fabric

Lower the presser foot and start sewing.

Guide the fabric edge along the guide of the foot while sewing.

Patchwork

- ① Stitch pattern: 08, 11, 17, 20
- ② Thread tension dial: 3 to 6
- ③ Presser foot: Satin stitch foot F

Seam patchwork pieces with right sides together (see above).

Open seam allowance and press the fabrics flat.

Sew stitch pattern on the right side of the fabric centering over the seam line.

- ① Right side of fabric
- ② Seam line

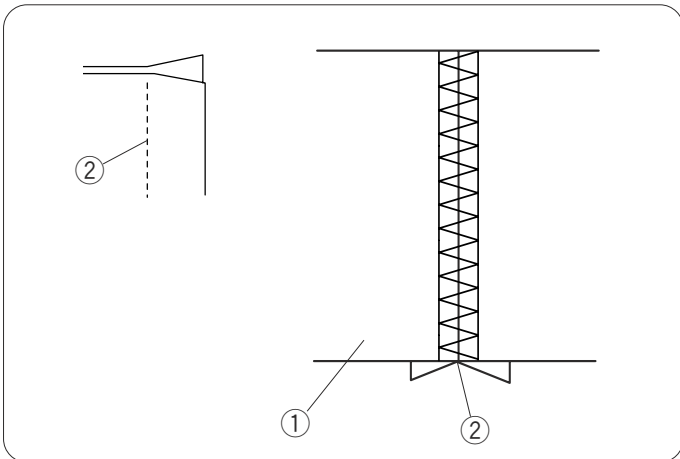
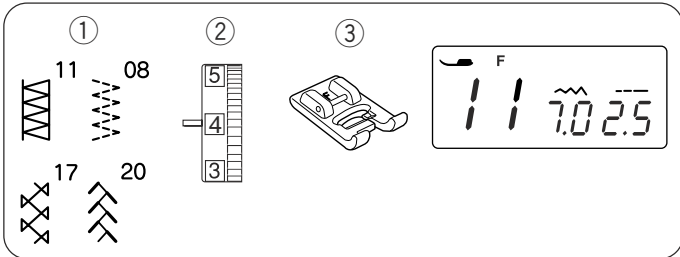
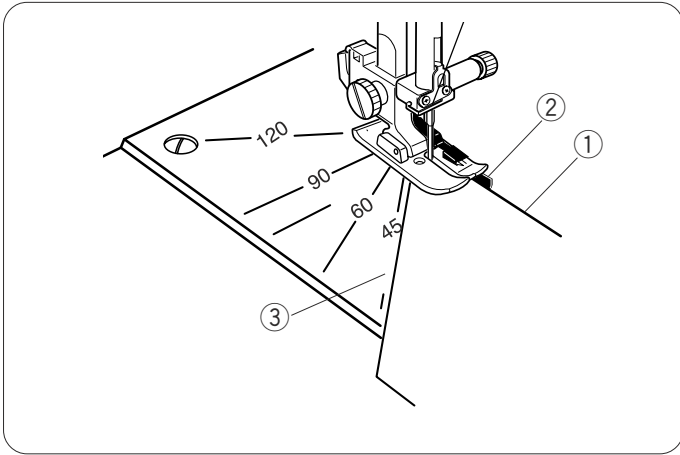
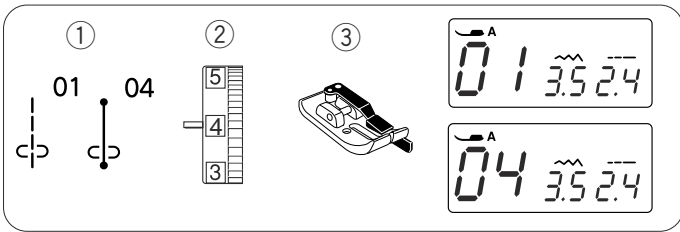

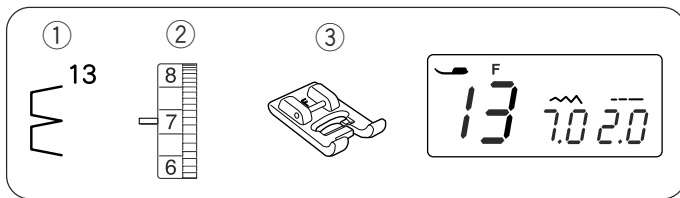

Shelltuck Tuck

- ① Stitch pattern: 13
- ② Needle thread tension: 6 to 8
- ③ Presser foot: Satin stitch foot F

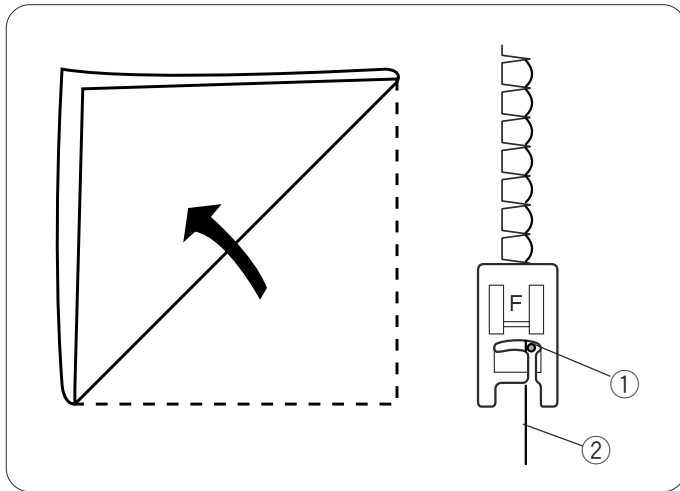

Use a lightweight fabric (tricot, for example).

Fold the fabric in bias as shown and stitch on the fold.

Allow the needle to barely clear the folded edge to create a shelled edge.

- ① Needle
- ② Fold

If you sew rows of shell tuck, space the rows at least 1.5 cm (5/8") apart.

You can also sew shell tuck on knits or soft silky woven fabrics, in any direction.

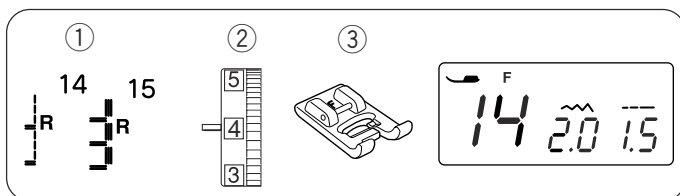

Applique

- ① Stitch pattern: 14 or 15
- ② Needle thread tension: 1 to 4
- ③ Presser foot: Satin stitch foot F

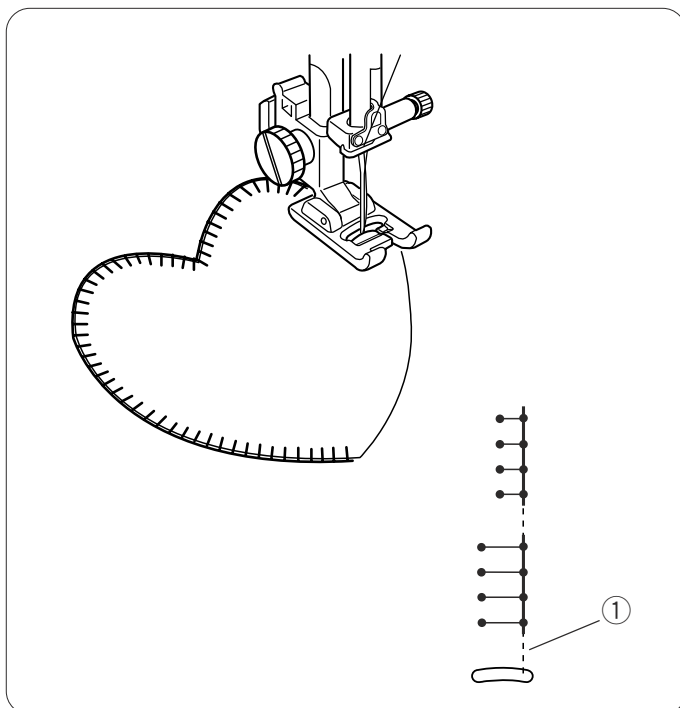

Place an applique on the fabric and baste or pin it in place.

Reduce the foot pressure (refer to page 8).

Lower the needle at the outer edge of the applique.

Sew while guiding the fabric so the needle falls along the outer edge of the applique.

When turning a sharp corner, stop the machine with the needle at the outer edge of the applique.

Raise the foot and pivot the fabric around the needle.

The stitch width can be changed from 1.0 to 5.0.

The right needle drop position will not move when changing the stitch width.

- ① Right needle drop position

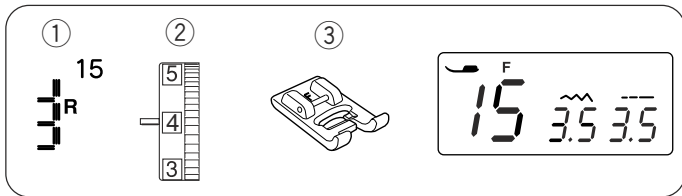

Fringing

- ① Stitch Pattern: 15
- ② Thread tension dial: 3 to 6
- ③ Presser foot: Satin stitch foot F

Fringing adds a special touch on table linens and shawls. Choose a firm, woven fabric like linen where threads can be removed easily.

Carefully cut the fabric on the grain. Remove a single strand of yarn or thread where the fringing is to begin.

Sew down the left side so the right hand stitches fall in the open space.

Remove all excess yarn located to the right of the stitching and create a fringe.

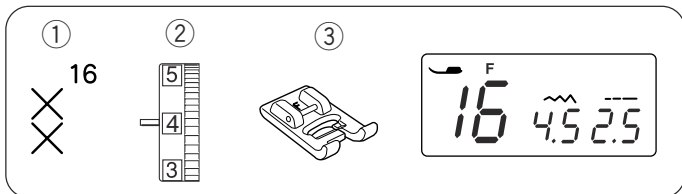
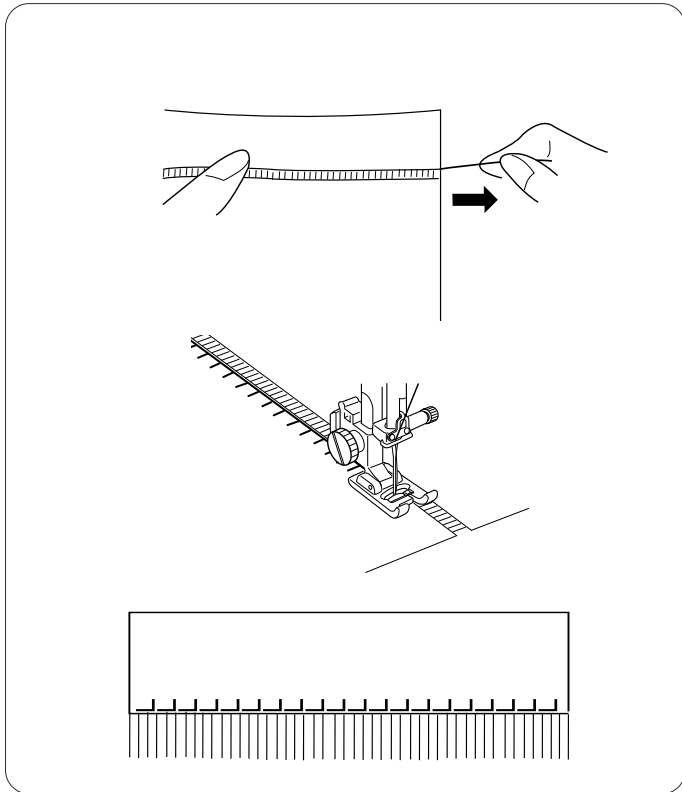

Cross Stitch

- ① Stitch Pattern: 16
- ② Thread tension dial: 3 to 6
- ③ Presser foot: Satin stitch foot F

You can make cross stitch designs with these patterns, in half the time it would take if embroidered by hand.

Use a plain close woven fabric such as linen or wool flannel. If you use light weight fabric, apply a tear away backing for support.

Sew from the center of the design outward.

If you press the auto lock button before sewing, the machine will sew one unit of the cross stitch and stop automatically.

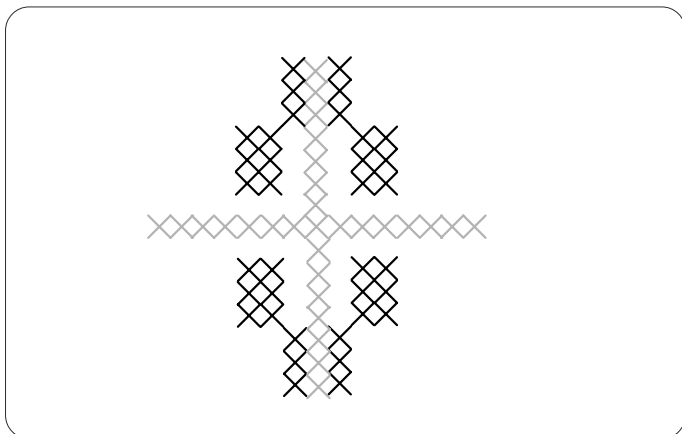

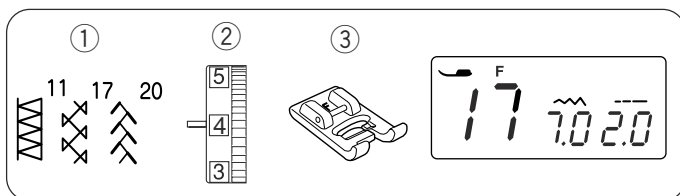

Fagoting

- ① Stitch pattern: 11, 17, 20
- ② Thread tension dial: 3 to 6
- ③ Presser foot: Satin stitch foot F

Use these stitches to join two pieces of fabric to create an open work appearance and add design interest.

Fold under each fabric edge 1.5 cm (5/8") and press. Pin the two edges to paper or tear backing 0.3–0.4 cm (1/8") apart.

Sew slowly, guiding the fabric so the needle catches the folded edge on each side.

After sewing is finished, tear away the paper.

- ① 0.3–0.4 cm (1/8")
- ② Paper

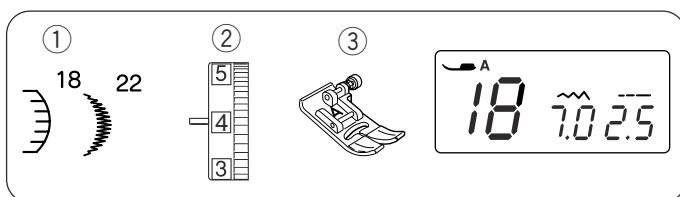
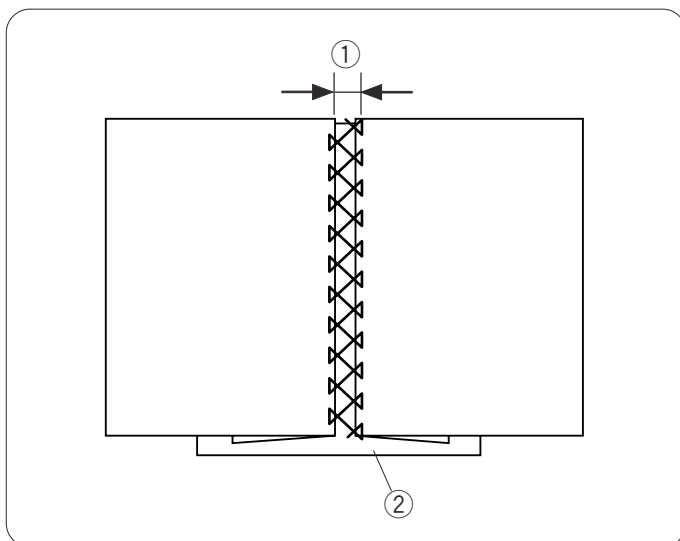

Scallop Stitch

- ① Stitch pattern: 18, 22
- ② Thread tension dial: 3 to 6
- ③ Presser foot: Zigzag foot A

Sew the stitches approximately 1 cm (3/8") inside the fabric edge.

Trim the outside of the stitches as shown. Make sure not to cut the thread.

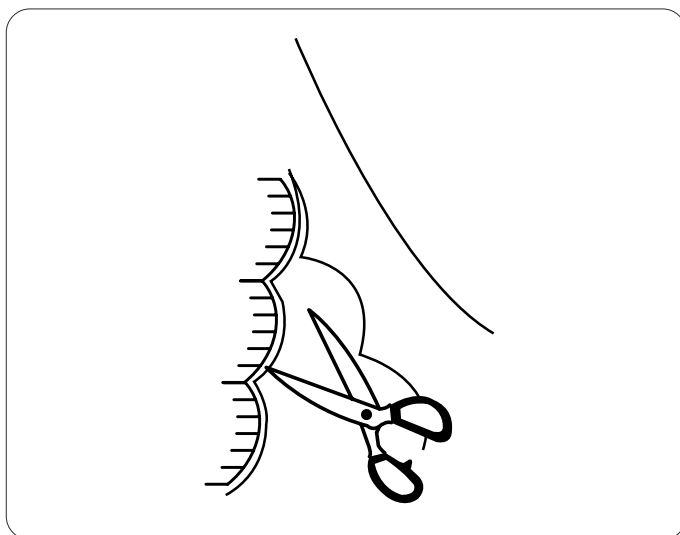

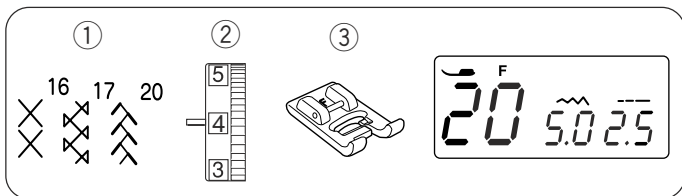

Smocking

- ① Stitch pattern: 16, 17, 20
- ② Thread tension dial: 3 to 6
- ③ Presser foot: Satin stitch foot F

Smocking is a delicate decorative treatment used on children's clothes or women's blouses.

Use a soft and lightweight fabric such as batiste, gingham or challis.

Cut the fabric three times wider than the projected width.

Select straight stitch, set stitch length at "5.0" and loosen the thread tension.

Sew rows of straight stitches 1 cm (3/8") apart across the area to be smocked. Knot the threads along one edge.

From the other edge, pull the bobbin threads to distribute the gathers evenly.

- ① 1 cm (3/8")
- ② Knotted thread

Set the thread tension to 3–6 and select a smocking stitch pattern.

Sew the smocking stitch pattern between the rows of straight stitches.

Remove the straight stitches by pulling them out.

- ③ Straight stitch

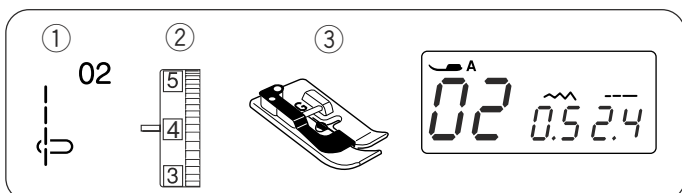
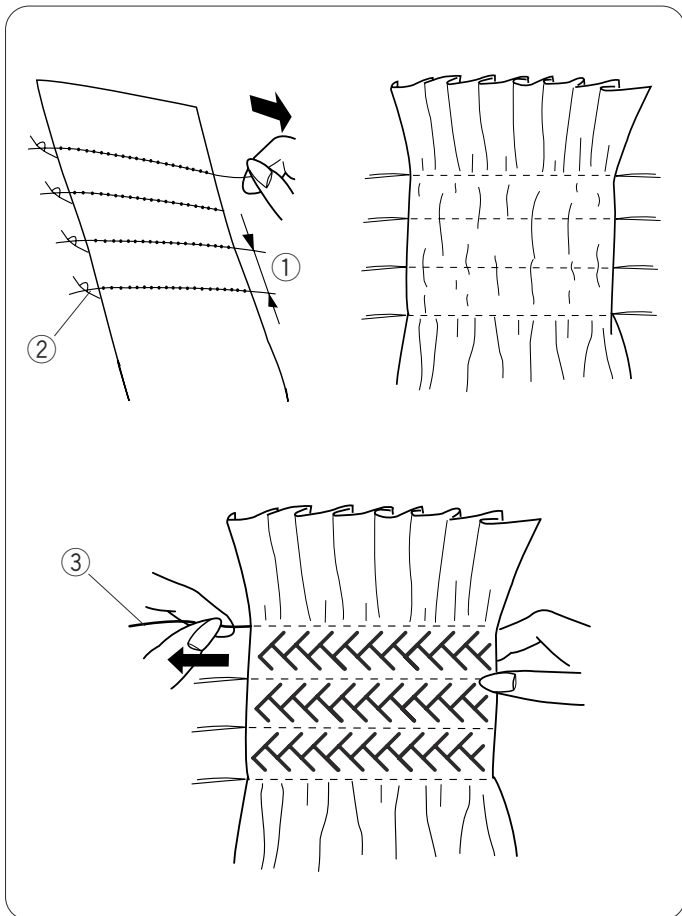

Pintucking

- ① Stitch pattern: 02
- ② Thread tension dial: 3 to 6
- ③ Presser foot: Blind hem stitch foot G

Fold a fabric with right side together.

Place the folded fabric under the foot.

Align the folded edge with the guide on the foot and lower the foot.

Sew while guiding the folded edge along the guide.

Open the fabric and press the tucks to one side.

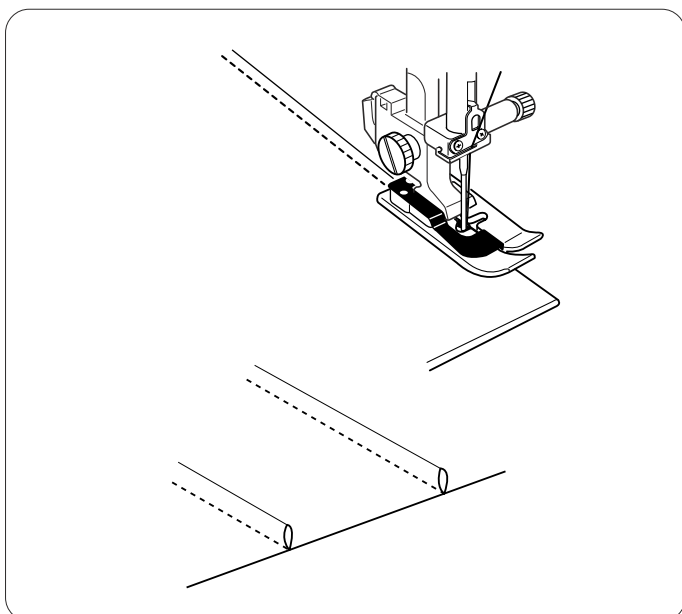

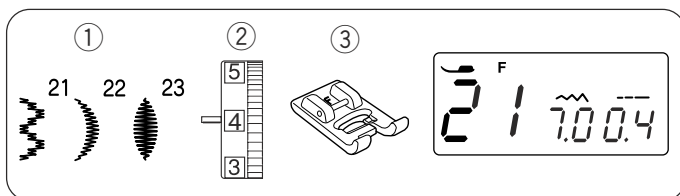

Satin Stitches

Machine settings

- ① Stitch pattern: 21, 22, 23
- ② Thread tension dial: 3 to 6
- ③ Presser foot: Satin stitch foot F

Satin stitches are used as decorative stitches on table linen etc.

Test sew if you reduce the stitch length to ensure smooth feed of the fabric.

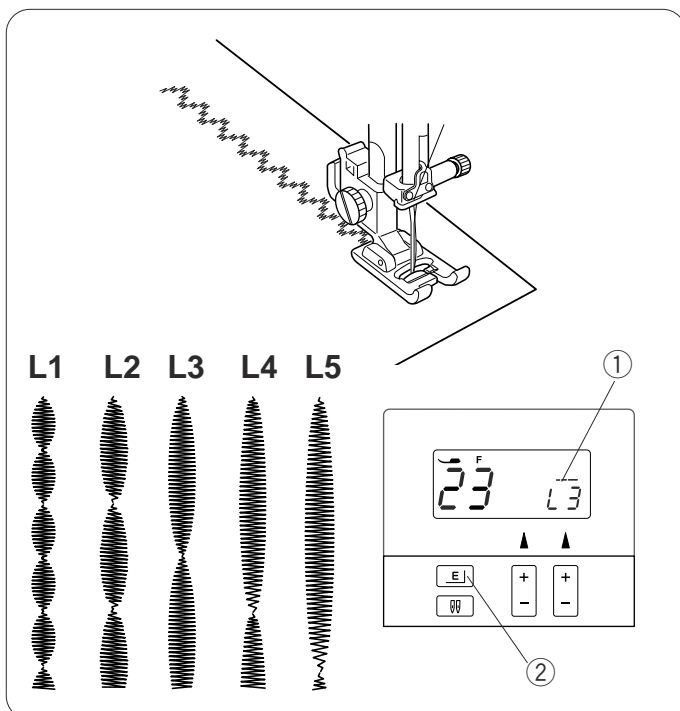

These stitches can be elongated up to 5 times their original length while the stitch density remains the same.

Press the elongation button to select the desired elongation ratio.

Elongation ratio is indicated in multiples of the original pattern length; L1 (original length) to L5.

- ① Elongation button
- ② Elongation ratio

The stitch length and width can also be changed.

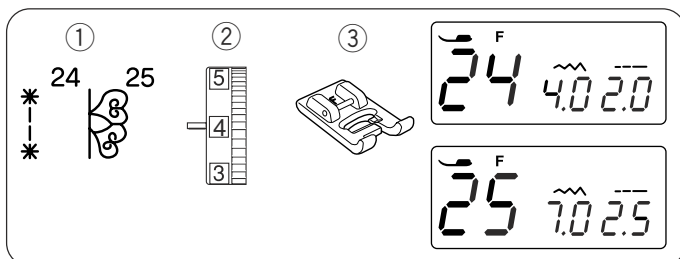

Decorative Stretch Stitches

Machine settings

- ① Stitch pattern: 24 or 25
- ② Thread tension dial: 3 to 6
- ③ Presser foot: Satin stitch foot F

Decorative stretch stitches are used for adding a creative and personalized touch to items.

Carefully guide the fabric while sewing as the fabric moves back and forth.

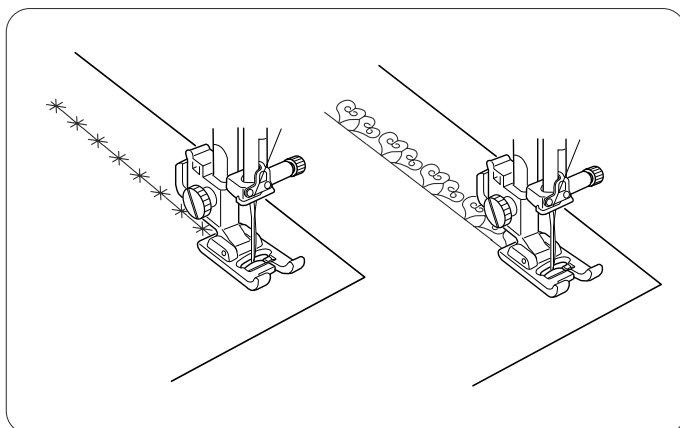

Twin Needle Sewing

CAUTION:

Turn off the machine before changing the needle or threading the machine.

Make sure to press the twin needle button before sewing with twin needle.

Do not use twin needles other than one included in the standard accessories, otherwise the needle may hit the needle plate, foot or hook and break.

Machine Setting

- ① Stitch pattern: See left
- ② Thread tension dial: 3 to 6
- ③ Presser foot: Zigzag foot A or Satin stitch foot F

NOTES:

Use #60 or finer threads.

Test the stitches before you begin to sew.

Threading the machine for twin needle

Raise the needle to the highest position and raise the presser foot.

Attach the extra spool pin and place a spool of thread on the extra spool pin (refer to page 13).

- ① Extra spool pin

Draw both threads from the spools and pass them through the points from ① to ⑦.

Make sure that the two strands of thread do not get tangled.

Pass one of the threads through the needle bar thread guide on the left, and the other on the right.

- ② Needle bar thread guide

Thread the needles from the front to back by hand.

NOTES:

Threading of points ① to ⑤ is the same as for single needle.

The needle threader cannot be used for the twin needle.

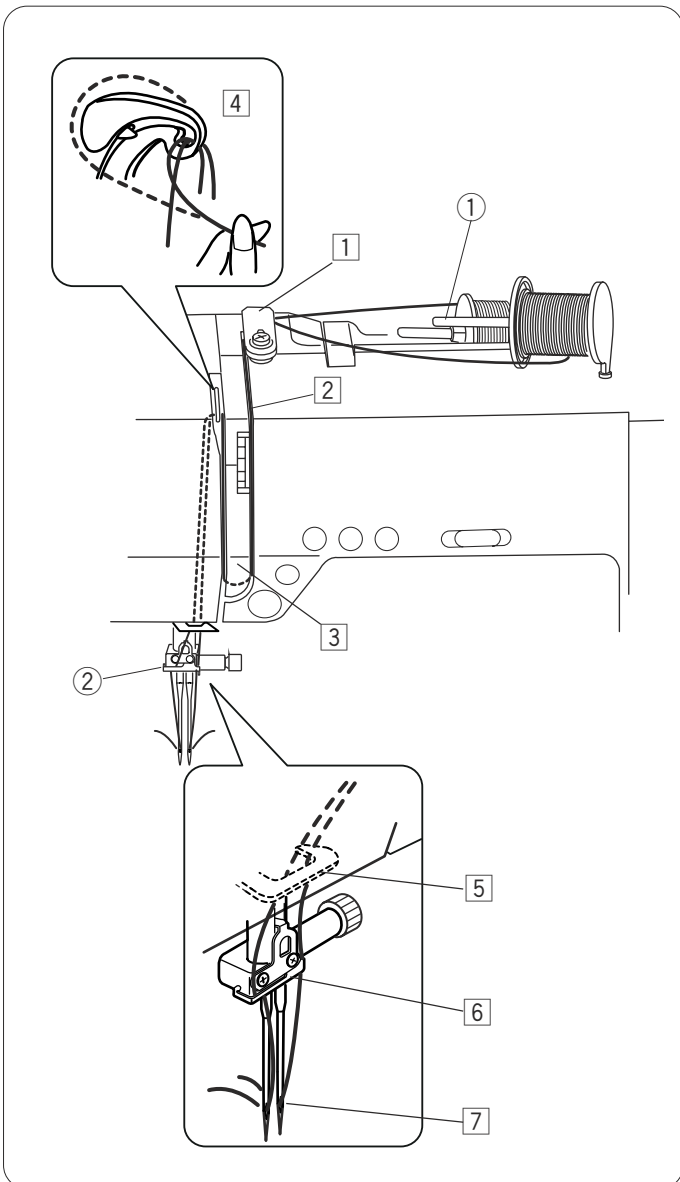
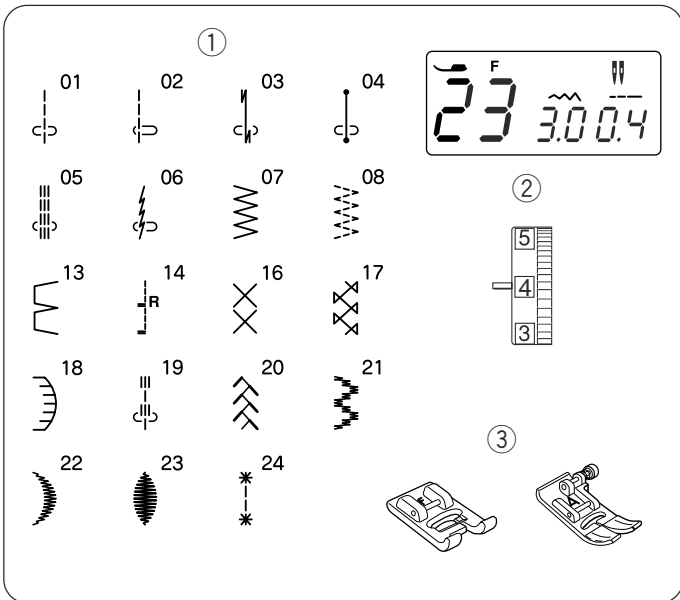

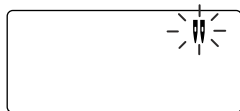
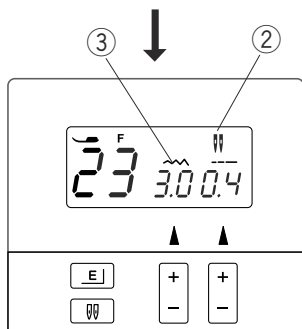
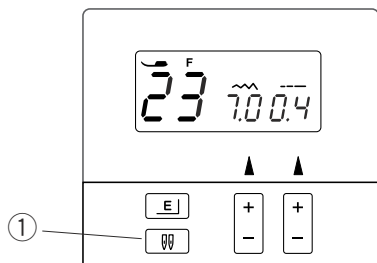

Selecting the patterns

Select the desired pattern suitable for twin needle sewing.

Press the twin needle button.

- ① Twin needle button

The LCD screen shows a twin needle icon and the maximum permissible stitch width is restricted to 3.0 mm.

The needle drop position of straight stitches is restricted to between 2.0 and 5.0.

- ② Twin needle icon
- ③ Maximum width (3.0)

NOTES:

If you press the twin needle button, a warning signal sounds and the twin needle icon blinks when a pattern not suitable for twin needle sewing is selected. After pressing the twin needle button, patterns not suitable for twin needle sewing cannot be selected. If you press the twin needle button again, the LCD screen shows only the blinking twin needle icon and all the buttons except for the twin needle button will be deactivated. Press the twin needle button again to change the setting to single needle sewing.

Sewing

Sew at a medium speed.

When changing the sewing direction, raise the needle from the fabric.

NOTE:

Use the thread cutter on the face plate when sewing with the twin needle.

MACHINE SETTINGS

Machine Setting Mode

In the setting mode buzzer sound and needle stop position can be set to your preference.

Entering the setting mode

Turn the power switch on while pressing and holding the thread cutter button. Keep the thread cutter button pressed until the LCD screen shows the buzzer setting mode (**01onof**).

- ① Thread cutter button

Buzzer sound setting

The default setting is ON and “on” sign is blinking.

Press the “+” sign of the stitch length adjusting button to turn off or turn on buzzer.

Each time you press the button “of” and “on” signs blink alternately.

- ② Stitch length adjusting button

Press the auto-lock button to save the new setting and return to the normal sewing mode.

- ③ Auto-lock button

Or press the thread cutter button to go to the needle stop position setting mode (**02UPdn**).

- ④ Thread cutter button

Needle stop position setting

The default setting is DOWN and “dn” sign is blinking.

Press the “+” sign of the stitch width adjusting button to select the needle stop position up or down.

Each time you press the button “UP” and “dn” signs blink alternately.

- ⑤ Stitch width adjusting button

Press the auto-lock button to save the new setting and return to the normal sewing mode.

NOTE:

If you turn off the machine without pressing the auto-lock button, the new setting will not be saved.

Correcting Deformed Stitch Patterns

The sewing results of stretch stitch patterns may vary depending on sewing conditions, such as sewing speed, fabric type, number of layers etc.

If stretch stitch patterns are deformed, correct them by turning the feed balancing dial with the screwdriver.

If the pattern is compressed, turn the dial in the direction of “+”.

If the pattern is drawn out, turn the dial in the direction of “-”.

- ① Feed balancing dial

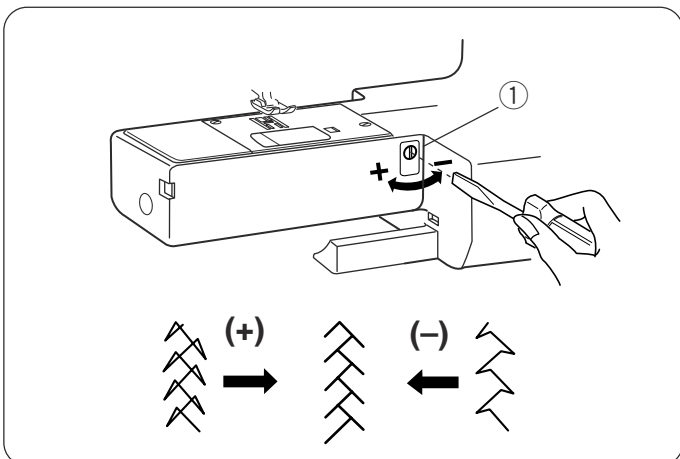
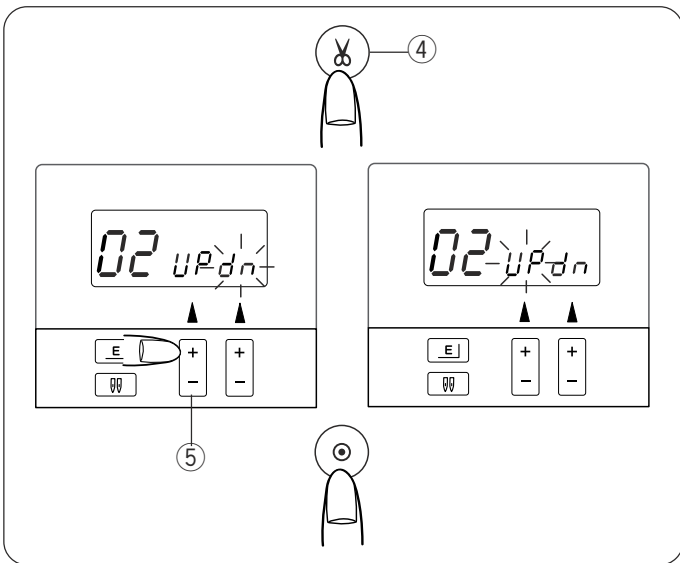
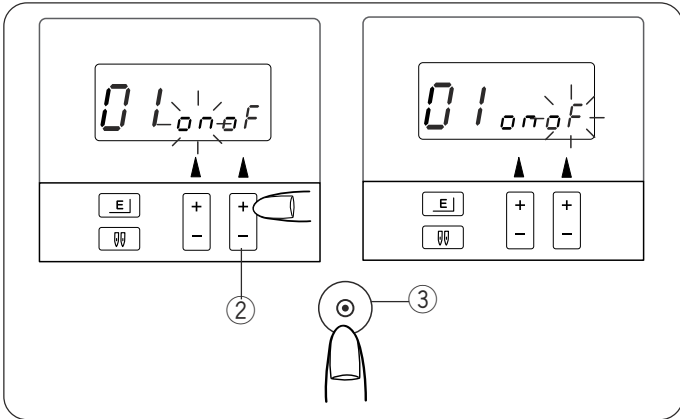
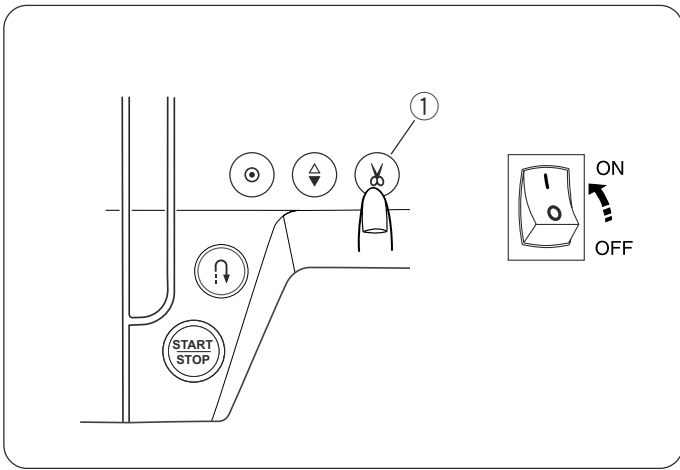

CARE OF YOUR MACHINE

Cleaning the Hook Race and Feed Dog

WARNING:

Turn the power switch off and unplug the machine before cleaning.
Do not dismantle the machine other than as explained in this section.

CAUTION:

Do not store the machine in a high-humidity area, near a heat radiator, or in direct sunlight.

NOTE:

Clean the outside of the machine with a soft cloth and neutral soap.

Press the needle up/down button to raise the needle, then unplug the sewing machine.

Remove the needle and presser foot.

Remove the hook cover plate by sliding the hook cover plate release button to the right. Take out the bobbin. Brush out dust and lint. (You may also use a vacuum cleaner.)

1 Remove the setscrews on the left hand side of the needle plate with the screwdriver supplied with the machine. Remove the needle plate.

- ① Setscrew
- ② Needle plate

2 Lift up the bobbin holder and remove it.

- ③ Bobbin holder

3 Clean the bobbin holder with a lint brush.

- ④ Lint brush

4 Clean the feed dog, thread cutter mechanism and hook race with the lint brush.

- ⑤ Feed dog
- ⑥ Thread cutter mechanism
- ⑦ Hook race

5 Clean the inside of the hook race with a dry cloth.

You may also use a vacuum cleaner.

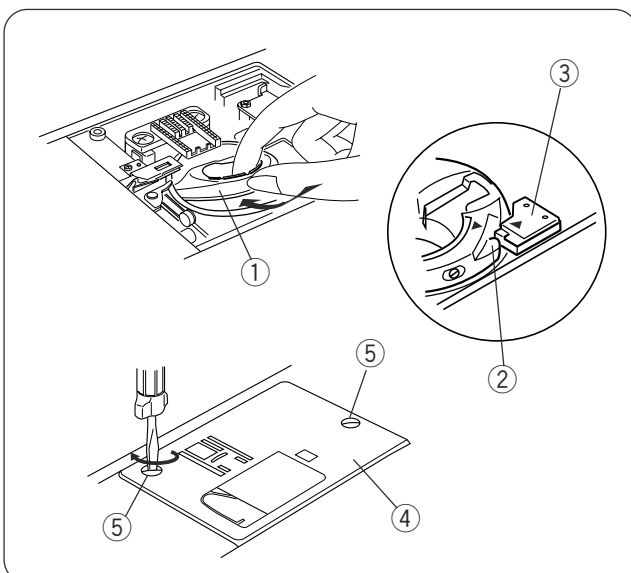
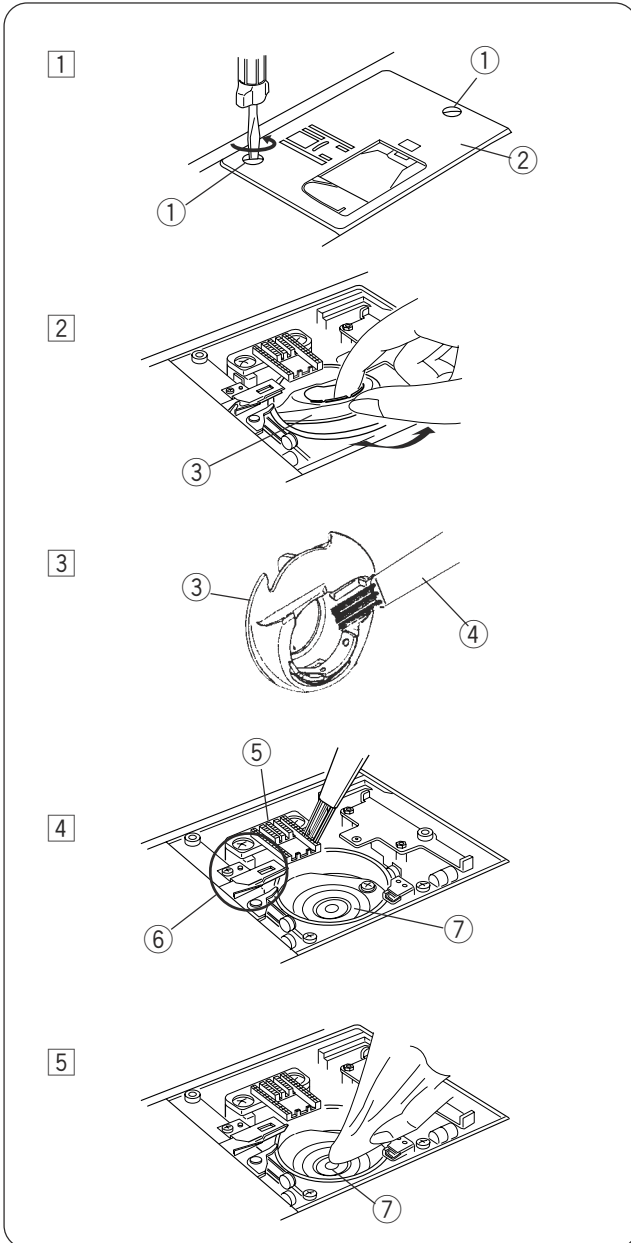

Installing the Bobbin Holder

Insert the bobbin holder so that the knob fits next to the stopper in the hook race.

- ① Bobbin holder
- ② Knob
- ③ Stopper

Insert the bobbin.

Attach the needle plate with the setscrews.

After cleaning the machine, make sure the needle and presser foot are attached.

- ④ Needle plate
- ⑤ Setscrew

Problems and Warning Signs

Audible signal	The buzzer sounds when:
Pip	Normal operation
Pip-pip-pip	Invalid operation
Pip-pip-peep	Buttonhole sewing completed
Peep	Malfunction

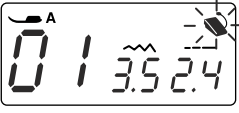
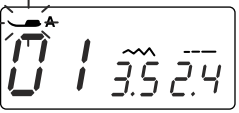
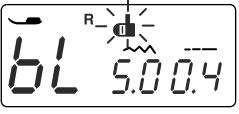
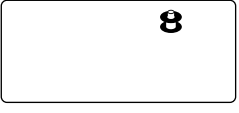
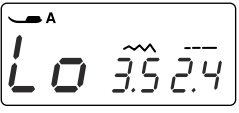
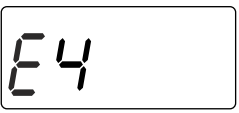
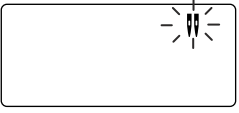
Warning sign	Cause	Try this
	The machine will not sew with the start/stop button because the foot control is connected.	Disconnect the foot control and start the machine.
	The machine will not sew because the presser foot is not lowered.	Lower the presser foot lifter and start the machine.
	A buttonhole is sewn without lowering the buttonhole lever.	Lower the buttonhole lever and restart the machine.
	The bobbin winder spindle is moved to the right.	Move the bobbin winder spindle to the left.
	The machine is restarted too soon after it has halted due to the overload.	Wait for at least 15 seconds to restart. If threads are jamming, remove the jammed threads.
	Auto thread cutting error due to a problem in the electronic components or tangled threads in hook area.	Remove the jammed threads in the hook area. If the error occurs again after cleaning the hook area, contact the service center or the store from where the machine was purchased.
	The twin needle button is pressed when the machine has been in the twin needle sewing mode.	Press the twin needle button to return to the twin needle sewing mode. Or turn off the machine and change to the single needle for normal sewing.

Clean the outside of the machine with a soft cloth. Do not use chemical solvent.

Store the machine in cool dry place.

Do not store the machine in area of high humidity, near a radiator or in direct sunshine.

It is not abnormal that a faint humming sound comes out from inside the machine.

LCD screen and pattern selection buttons may get warm when the machine has been used for hours.

Accumulated bobbin thread residues may cause auto thread cutting errors. Contact an authorized dealer or service center to remove thread residues from inside the free arm cover.

Troubleshooting

Condition	Cause	Reference
The needle thread breaks.	<ol style="list-style-type: none"> 1. The needle thread is not threaded properly. 2. The needle thread tension is too tight. 3. The needle is bent or blunt. 4. The needle is incorrectly inserted. 5. The needle thread is not set under the presser foot when sewing is started. 6. The thread is either too heavy or too fine for the needle. 	<p>See page 16</p> <p>See page 9, 10</p> <p>See page 12</p> <p>See page 12</p> <p>See page 19</p> <p>See page 12</p>
The bobbin thread breaks.	<ol style="list-style-type: none"> 1. The bobbin thread is not threaded properly in the bobbin holder. 2. Lint has collected in the bobbin holder. 3. The bobbin is damaged and doesn't turn smoothly. 4. The thread is wound loosely on the bobbin. 	<p>See page 15</p> <p>See page 49</p> <p>Replace the bobbin.</p> <p>See page 14</p>
The needle breaks.	<ol style="list-style-type: none"> 1. The needle is incorrectly inserted. 2. The needle clamp screw is loose. 3. The threads were not drawn to the rear after sewing. 4. The needle is too fine for the fabric being used. 5. The presser foot is not appropriate for the stitch pattern being sewn. 	<p>See page 12</p> <p>See page 12</p> <p>See page 20</p> <p>See page 12</p> <p>Change the presser foot.</p>
Skipped stitches	<ol style="list-style-type: none"> 1. The needle is incorrectly inserted, bent or blunt. 2. The needle and/or threads are not suitable for the work being sewn. 3. A Blue Tipped needle is not being used for sewing stretch, very fine fabrics and synthetics. 4. The needle thread is not threaded properly. 5. A poor quality needle is used. 	<p>See page 12</p> <p>See page 12</p> <p>See page 12</p> <p>See page 16</p> <p>Replace the needle.</p>
Seam puckering	<ol style="list-style-type: none"> 1. The needle thread tension is too tight. 2. The needle thread is not threaded properly. 3. The needle is too heavy for the fabric being sewn. 4. The stitch length is too long for the fabric. 	<p>See page 9, 10</p> <p>See page 16</p> <p>See page 12</p> <p>Make the stitches shorter.</p>
The cloth is not feeding smoothly.	<ol style="list-style-type: none"> 1. The feed dog is packed with lint. 2. The stitches are too fine. 3. The feed dog is not raised after "drop feed" sewing. 	<p>See page 49</p> <p>Make the stitches longer.</p> <p>See page 11</p>
Stitches form loops below the works.	<ol style="list-style-type: none"> 1. The needle thread tension is too loose. 2. The needle is either too heavy or too fine for the thread. 	<p>See page 9, 10</p> <p>See page 12</p>
The machine does not work.	<ol style="list-style-type: none"> 1. The machine is not plugged in. 2. Thread has been caught in the hook race. 3. The bobbin winder spindle is not returned to the left after bobbin winding. 	<p>See page 4</p> <p>See page 49</p> <p>See page 14</p>
Buttonhole is not sewn properly.	<ol style="list-style-type: none"> 1. The stitch density is not suitable for the fabric being sewn. 2. Suitable interface material has not been used for the stretch or synthetic fabric. 3. Buttonhole lever is not pulled down. 	<p>See page 31</p> <p>Use an interfacing.</p> <p>See page 29</p>
The machine does not run smoothly and is noisy.	<ol style="list-style-type: none"> 1. Thread has been caught in the hook race. 2. Lint has built up in the hook race or bobbin holder. 	<p>See page 49</p> <p>See page 49</p>
Auto thread cutting fails.	<ol style="list-style-type: none"> 1. Thread being used is too thick. 2. Threads are tangled in auto thread cutter mechanism. 	<p>See page 20</p> <p>See page 49</p>

