

PFAFF
Perfection starts here.™



creative™ 3.0
Owner's manual



Congratulations!

Congratulations on purchasing your new PFAFF® creative™ 3.0 sewing and embroidery machine.

As a sewing enthusiast, you have acquired one of the most advanced and comprehensive sewing and embroidery machines in the world; it will enable you to transform all your creative ideas into reality using the most highly tuned technology and features.

Before you start, please spend some time reading this owner's manual. You will soon discover how to maximize the use of your machine. Our authorized PFAFF® dealers will of course also be pleased to advise you at any time.

Your PFAFF® creative™ 3.0 sewing and embroidery machine will definitely enable you to experience a totally new dimension of sewing and embroidery.



TABLE OF CONTENTS

1

Introduction 1:7

Machine overview	1:8
Front side	1:8
Rear side	1:9
Top parts	1:9
Accessory tray	1:9
Parts of the embroidery unit	1:9
Included accessories	1:10
Presser feet	1:11
Stitch overview	1:12
Utility stitches	1:12
Decorative stitches	1:15
Alphabets	1:16

2

Preparations 2:1

Unpacking	2:2
Connecting the foot control cord	2:2
Connect the power cord and foot control	2:2
Pack away after sewing	2:3
LED lights	2:3
Free arm	2:3
Thread cutter	2:3
Spool pins	2:4
Threading the machine	2:5
Needle threader	2:5
Thread sensor	2:6
Bobbin winding	2:7
Inserting the bobbin	2:8
IDT™ system (Integrated Dual Feed)	2:8
Changing the presser foot	2:9
Changing the needle	2:9
Lowering feed dogs	2:9
Needles	2:10
Threads	2:11
Stabilizers	2:11
USB port	2:12
USB embroidery stick	2:12
Complimentary software (PC)	2:12
How to update your machine	2:13

3

Machine settings & buttons 3:1

Touch screen	3:2
Touch screen - overview	3:2
Settings menu	3:3
Machine settings	3:3

Sewing settings	3:4
Embroidery settings	3:5
Machine information	3:5

Buttons and indicators	3:6
Common icons	3:8

4

Sewing mode 4:1

Sewing mode	4:2
Start view	4:2
Sewing mode - overview	4:2
Selection menu	4:3
Selecting a stitch	4:3
Selecting a font	4:3
Stitch settings	4:4
Stitch width	4:4
Stitch positioning	4:4
Stitch length	4:5
Stitch density	4:5
Balance	4:5
Thread tension	4:6
Mirroring	4:6
Save to personal menu	4:7
Free-motion options	4:8
Tie-off options	4:10
Sewing programs	4:11
Sequencing	4:12
Stitch Creator	4:12
Sewing techniques	4:13
Sewing in zippers	4:13
Sewing hems in heavy fabric	4:13
Three-step zigzag stitch	4:14
Blindhem stitch	4:14
Buttonholes	4:15
Sew on a button	4:17
Darning	4:17
Quilting	4:18
Special sewing techniques	4:20
Common sewing pop-ups	4:21

5

Sequencing 5:1

Sequencing	5:2
Sequencing - overview	5:2
Open and exit sequencing	5:3
Create a sequence	5:3
Sequence commands	5:4
Loading and sewing a sequence	5:5
Saving a sequence	5:5
Important sequencing information	5:6
Common sequencing pop-ups	5:6

6

Stitch Creator™ feature 6:1

Stitch Creator™ feature	6:2
Stitch Creator™ feature - overview	6:2
Open and exit Stitch Creator™ feature.....	6:3
Definition of a stitch point	6:3
Start creating - add a stitch or stitch point	6:3
Select stitch points	6:3
Duplicate selected stitch point.....	6:4
Insert a new stitch point	6:4
Triple stitch.....	6:4
Mirroring side to side	6:4
Mirroring end to end	6:4
Delete selected stitch point	6:4
Touch functions	6:5
Position of the marked stitch point	6:5
Loading and sewing a stitch	6:6
Saving a stitch	6:6
Common Stitch Creator™ feature pop-ups	6:6

7

Embroidery mode – preparations 7:1

Embroidery unit overview	7:2
Embroidery hoop overview	7:2
Attach the embroidery foot 6A	7:2
Built-in designs	7:3
creative™ 3.0 Embroidery collection	7:3
Connect the embroidery unit	7:3
Remove the embroidery unit	7:3
To hoop the fabric	7:4
Slide on/off the hoop	7:4
Getting started embroidering	7:5

8

Embroidery mode – edit 8:1

Embroidery mode - edit	8:2
Embroidery edit - overview	8:2
Selection menu	8:3
Load a design	8:3
Load a font	8:3
Load from personal files/USB device	8:3
Touch functions	8:4
Move.....	8:4
Scale.....	8:4
Rotate	8:4
Select design	8:5
Move design into hoop	8:5
Mirror a design	8:5
Delete a design	8:5

Option bar in embroidery edit	8:6
Save to personal files.....	8:6
Zoom options/pan.....	8:6
Select hoop.....	8:7
Embroidery text editor	8:7
Embroidery stitch-out.....	8:7
Embroidery edit pop-ups	8:8

9

Embroidery mode – stitch-out 9:1

To enter Embroidery stitch-out	9:2
Embroidery stitch-out - overview	9:2
Speed control	9:2
Crosshair	9:3
Basting	9:3
Monochrome	9:3
Step stitch by stitch	9:3
Thread tension	9:3
Embroidery information	9:4
Option bar	9:4
Basic precise positioning	9:4
Zoom options/pan.....	9:5
Hoop position	9:5
Color block list.....	9:6
Return to Embroidery edit.....	9:6
How to use basic precise positioning	9:7
Corner icons	9:8
Zoom to crosshair.....	9:8
Common Embroidery stitch-out pop-ups	9:9

10

Personal files 10:1

Personal files	10:2
File formats	10:2
Browse personal files	10:3
Load a file	10:3
Open a folder	10:3
Move up one folder level	10:3
Organize	10:4
Common personal files pop-ups	10:4

11

Maintenance 11:1

Cleaning the machine	11:2
Non-original parts and accessories	11:2
Troubleshooting	11:3
Index	11:5
Intellectual Property	11:12



Introduction 1

Machine overview

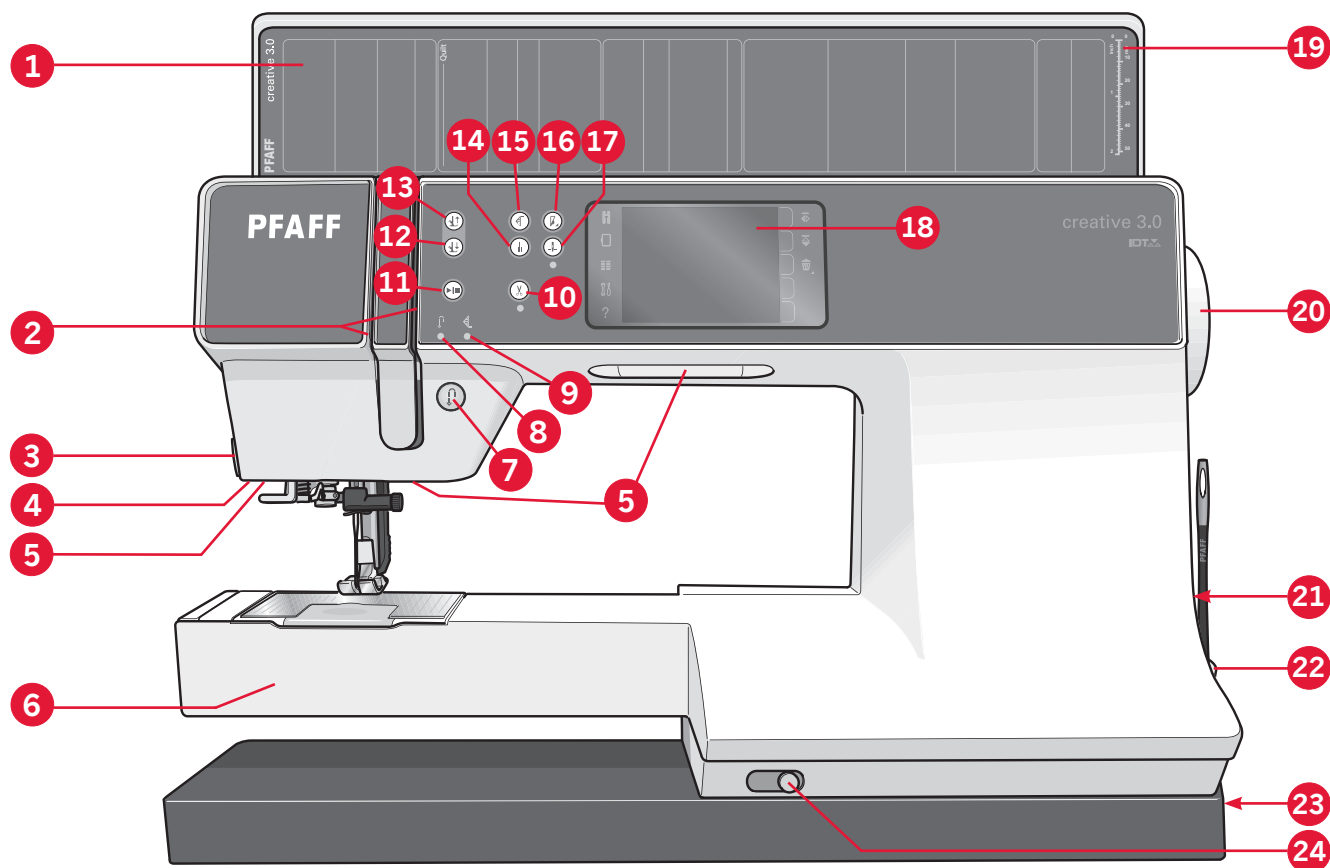

Front side

1. Lid with stitch categories
2. Threading slots
3. Thread cutter
4. Sensormatic buttonhole foot socket
5. LED lights
6. Free arm
7. Reverse
8. Reverse indicator
9. Action indicator
10. Thread snips
11. Start/stop
12. Presser foot down and pivot toggle
13. Presser foot up and extra lift toggle
14. Immediate tie-off
15. Stitch restart
16. Speed control
17. Needle up/down

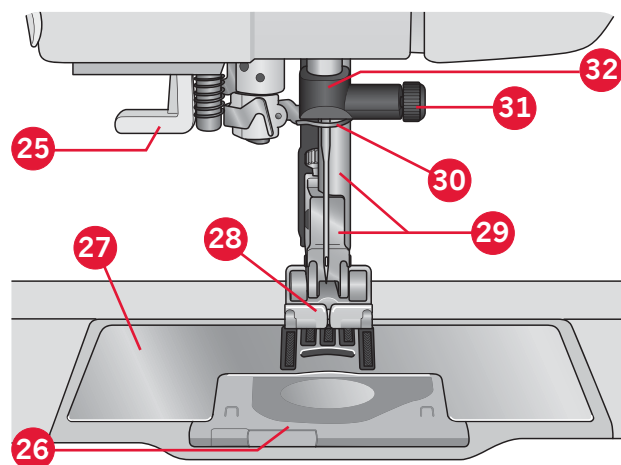

18. PFAFF® creative™ Color Touch Screen
19. Button ruler
20. Handwheel
21. Built-in USB port
22. Stylus holder
23. Main switch, connectors for power cord and foot control
24. Slide for lowering the feed dogs

Needle area

25. Built-in needle threader
26. Bobbin cover
27. Needle plate
28. Presser foot
29. Presser foot bar and presser foot holder
30. Needle thread guide
31. Needle screw
32. Needle bar

Rear side

- 33. Handle
- 34. IDT™ system
- 35. Embroidery unit connection socket

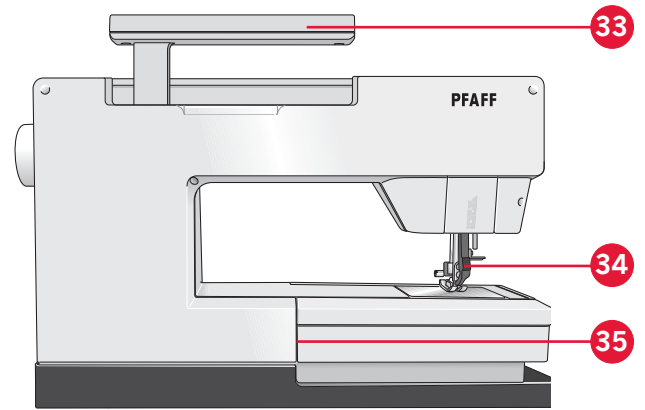

Top parts

- 36. Pre-tension disk for threading and bobbin winding
- 37. Bobbin winder thread guide
- 38. Thread guide
- 39. Bobbin winder thread guides
- 40. Bobbin winder thread cutter
- 41. Bobbin winder spindle
- 42. Auxiliary spool pin
- 43. Spool caps
- 44. Spool pin
- 45. Thread tension disk
- 46. Take-up lever

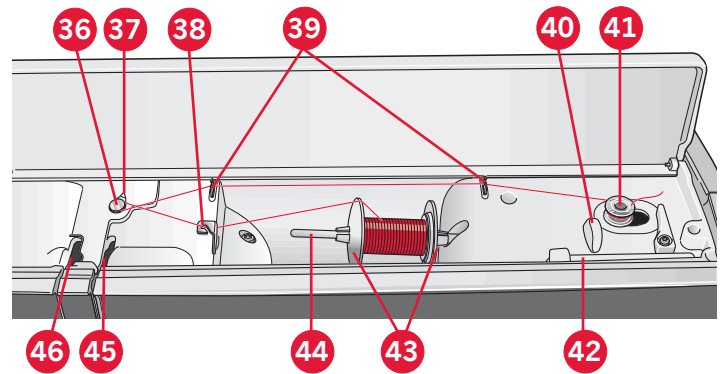

Accessory tray

The accessory tray features special compartments for presser feet and bobbins, plus space for needles and other accessories. Store the accessories in the tray so they are easily accessible.

- 47. Space for accessories
- 48. Removable tray for presser feet
- 49. Removable bobbin holder

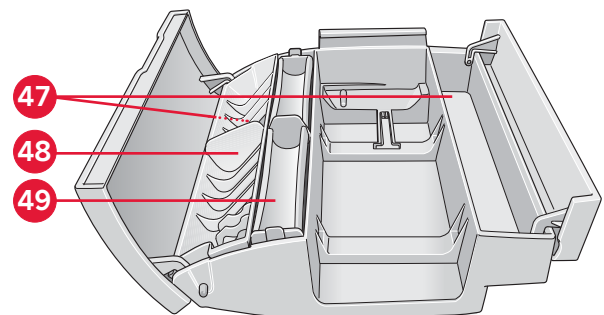

Parts of the embroidery unit

(type BE16)

- 50. Embroidery unit release button
- 51. Level adjusting feet
- 52. Embroidery unit socket
- 53. Embroidery hoop connection assembly
- 54. Embroidery arm

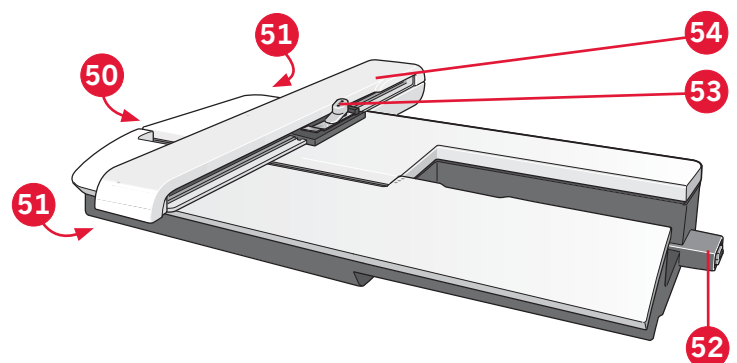

Included accessories

Accessories

- 55. Stylus
- 56. Thread net (1)
- 57. Edge guide
- 58. Felt pad (1)
- 59. USB embroidery stick
- 60. Screwdriver
- 61. Seam ripper
- 62. Brush
- 63. Spool cap, large (2)
- 64. Spool cap, medium
- 65. Spool cap, small
- 66. Multi-purpose tool
- 67. Bobbins (10)
- 68. Hoop clips

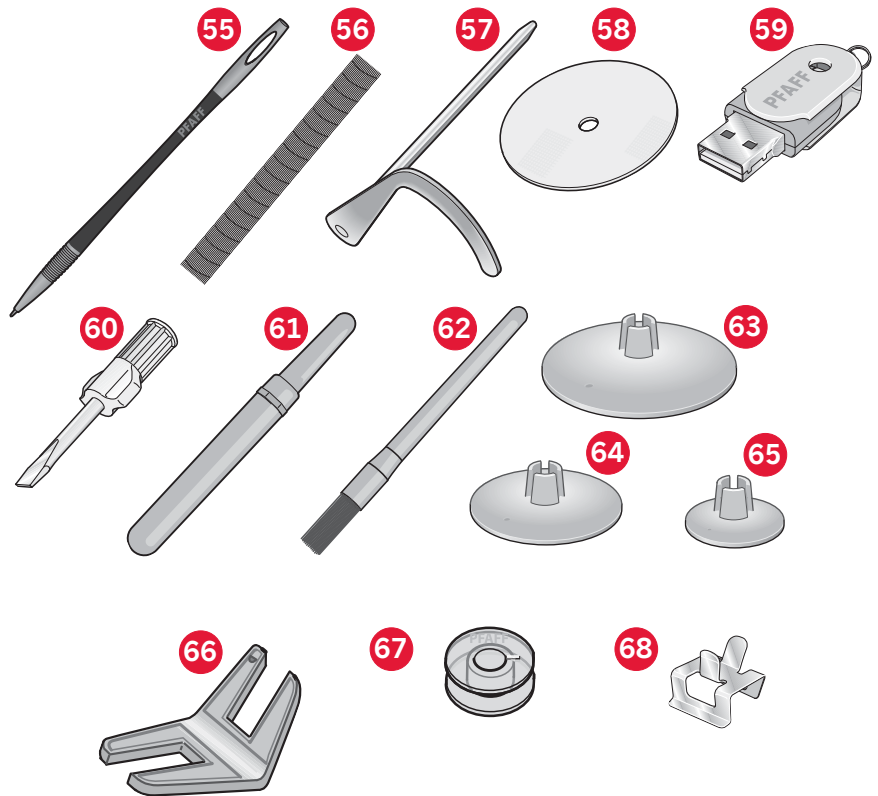

Included hoops

- 69. creative™ 120 Square hoop (120x120)
- 70. creative™ Elite hoop (260x200)

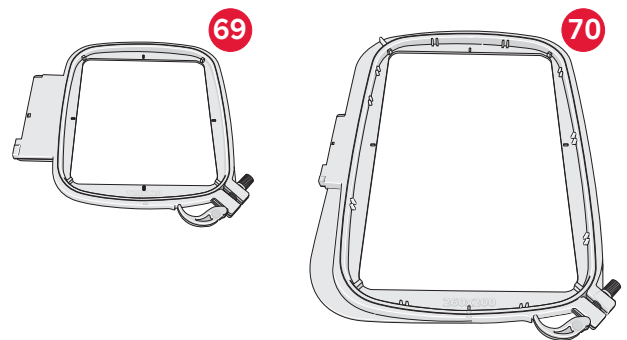

Included accessories not in picture

- Foot control
- Power cord
- Needles
- Microfiber cloth
- creative™ 3.0 Embroidery collection
- Quick start embroidery kit
- Warranty

Presser feet



0A - Standard presser foot for IDT™ system (attached on the machine upon delivery)

This foot is used mainly for straight stitching and zigzag stitching with a stitch length longer than 1.0mm.



1A - Fancy stitch foot for IDT™ system

This foot is used for decorative stitches. The groove on the underside of the foot is designed to flow smoothly over the stitches.



2A - Fancy stitch foot

When sewing decorative stitches or short zigzag stitches and other utility stitches with less than 1.0mm stitch length, use this foot. The groove on the underside of the foot is designed to flow smoothly over the stitches.

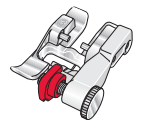

3 - Blindhem foot for IDT™ system

This foot is used for blindhem stitches. The toe on the foot guides the fabric. The red guide on the foot is designed to ride along the fold of the hem edge.



4 - Zipper foot for IDT™ system

This foot can be snapped on either the right or the left of the needle, making it easy to sew close to both sides of the zipper teeth. Move needle position to right or left to sew closer to zipper teeth.

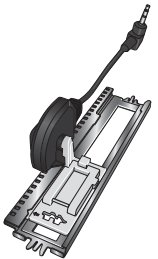

5A - Sensormatic buttonhole foot

When connected to the machine, the buttonhole is sewn in the length that has been entered into the machine.

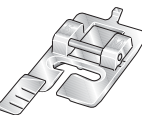

5M - Manual buttonhole foot

This foot is used for sewing manual buttonholes. Use the markings on the foot to position the garment edge. The finger on the back of the foot holds cording for corded buttonhole.



6A - Embroidery/Sensormatic free-motion foot





















This foot is used for embroidery and free-motion sewing. This foot can also be used for darning.

Important: Make sure that the IDT™ system is disengaged when using presser foot 2A, 5A, 5M, and 6A.

Stitch overview

Utility stitches

Stitch	Stitch number	Name	Description
	1.1.1	Straight stitch	For seaming and topstitching. Select from 37 different needle positions. <i>Note: This stitch makes a stronger tie-off than stitch 2.1.1.</i>
	1.1.2	Stretch triple straight stitch	Reinforced seam. Topstitching.
	1.1.3	Straight stitch reverse	Sew continuous reverse with strong tie-off.
	1.1.4	Basting stitch	Single stitch used for basting. Lower the feed dogs. Touch foot control to sew one stitch. Move fabric manually to desired position and touch foot control again to sew another stitch.
	1.1.5	Zigzag stitch	Reinforce seams, clean finish, stretch sewing, lace insertion.
	1.1.6	Zigzag stitch, right or left needle position	Reinforce seams, clean finish, stretch sewing.
	1.1.7	Z-zigzag stitch	Applique, couching, eyelets.
	1.1.8	Stretch triple zigzag stitch	Elastic stitch for decorative hems or topstitching.
	1.1.9	Three-step zigzag stitch	Sewing elastic, darning, patching and decorative sewing.
	1.1.10	Elastic stitch	Sewing elastic, darning, patching.
	1.1.11	Triple stretch stitch	Sewing elastic, darning, patching and decorative sewing.
	1.1.12	Honeycomb stitch	Decorative stitch for stretch fabrics and hems. Also used with elastic thread in the bobbin.
	1.1.13	Bridging stitch	Joining fabrics and quilt batting, decorative stitch for quilting, hemstitching.
	1.1.14	Foundation elastic stitch	Joining stitch for terry cloth, leather, bulky fabrics where overlapping the seams.
	1.1.15	Crosshem stitch	Elastic decorative hem for stretch fabrics.
	1.1.16	Blindhem stitch	Sewing blindhems on woven fabrics.
	1.1.17	Elastic blindhem stitch	Sewing blindhems on stretch fabrics.
	1.1.18	Stretch tricot stitch	Sewing seams on stretch fabrics.
	1.2.1	Closed overlock	Seam and overcast stretch fabrics in one step.

	1.2.2	Closed overlock	Seam and overcast in one step.
	1.2.3	Closed overlock	Seam and overcast in one step with reinforced edge.
	1.2.4	Elastic overcast	Seam and overcast stretch fabrics in one step.
	1.2.5	Standard overcast	Seam and overcast stretch fabrics in one step with reinforced edge.
	1.2.6	Overlock	Seam and overcast stretch fabrics in one step.
	1.2.7	Closed overlock	Seam and overcast in one step, patch, hem.
	1.2.8	Stretch knit overlock	Seam and overcast stretch fabrics in one step.
	1.2.9	Reinforced overlock	Seam and overcast stretch fabrics in one step and reinforce.
	1.2.10	Finished edge overlock	Seam and overcast stretch fabrics in one step with reinforced edge.
	1.2.11	Mock cover hem	Create the look of a serger cover hem for stretch fabrics.
	1.2.12	Open overlock blindhem	Create decorative overlock blindhem for woven fabrics.
	1.2.13	Closed overlock blindhem	Create decorative overlock blindhem for stretch fabrics.
	1.3.1	Linen buttonhole	Buttonhole for blouses, shirts and linen.
	1.3.2	Standard buttonhole	Basic buttonhole for blouses, shirts and jackets. Also for home décor.
	1.3.3	Rounded buttonhole with pointed tack	Buttonhole for garments.
	1.3.4	Rounded buttonhole with lengthwise tack	Buttonhole for garments.
	1.3.5	Eyelet buttonhole with pointed tack	Tailors buttonhole or decorative buttonhole.
	1.3.6	Eyelet buttonhole with lengthwise tack	Tailors buttonhole for jackets and trousers.
	1.3.7	Rounded buttonhole	Buttonhole for light garments or jackets.
	1.3.8	Stretch buttonhole	Buttonhole for stretch fabrics.
	1.3.9	Cross stitch buttonhole	Decorative buttonhole.

	1.3.10	Decorative eyelet buttonhole	Decorative buttonhole for jackets.
	1.3.11	Heirloom round buttonhole with pointed tack	Decorative heirloom buttonhole.
	1.3.12	Bound buttonhole	Foundation stitch for bound buttonhole.
	1.3.13	Button sewing	Sew on buttons or tacking. Lower the feed dogs.
	1.4.1	Decorative eyelet	Decorative eyelet for heirloom sewing.
	1.4.2	Programmable darning stitch	Darning holes or damaged fabric.
	1.4.3	Programmable reinforced darning stitch	Reinforced darning holes or damaged fabric.
	1.4.4	Bartack	Automatically reinforce seams and pockets.
	1.4.5	Denim bartack	Automatically reinforce seams and pockets decoratively.
	1.4.6	Decorative bartack	Automatically reinforce seams and pockets decoratively.
	1.4.7	Cross bartack	Automatically reinforce seams and pockets.

Decorative stitches

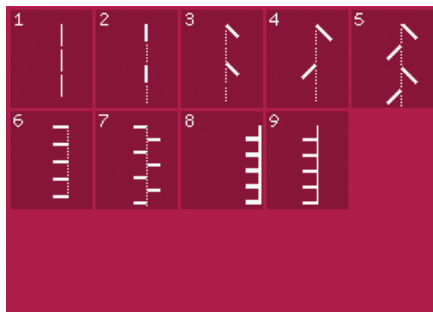

2.1 Quilt stitches -
Handlook stitches

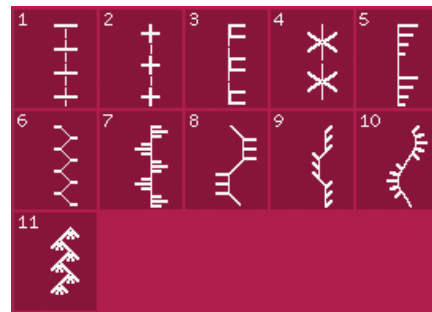

2.2 Quilt stitches -
Antique quilt stitches

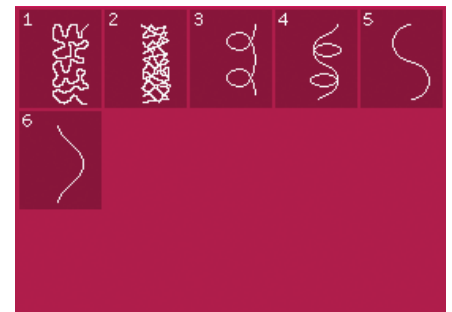

2.3 Quilt stitches -
Stippling stitches



2.4 Quilt stitches -
Crazy patch stitches



2.4 Quilt stitches -
Crazy patch stitches

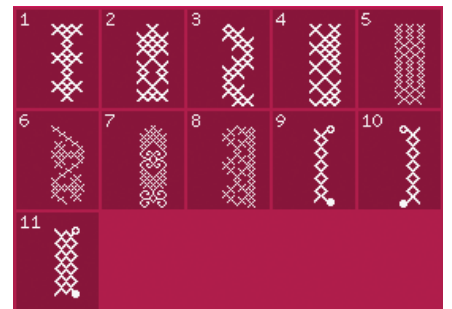

3.1 Needle art stitches -
Cross stitches

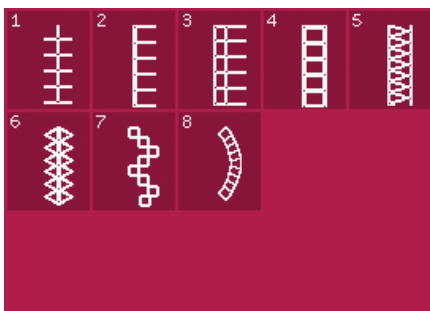

3.2 Needle art stitches -
Hemstitches



3.3 Needle art stitches -
Antique hand embroidery stitches



3.3 Needle art stitches -
Antique hand embroidery stitches



3.4 Needle art stitches -
Smocking stitches

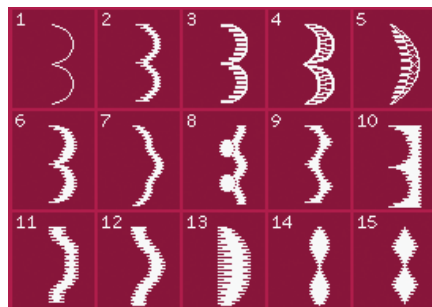

4.1 Decorative stitches -
Satin and edge stitches

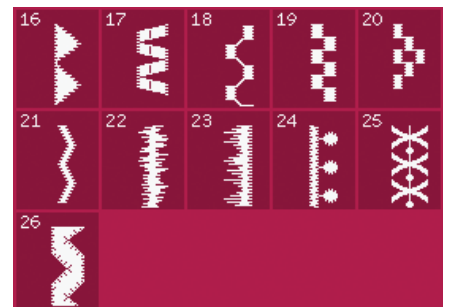

4.1 Decorative stitches -
Satin and edge stitches

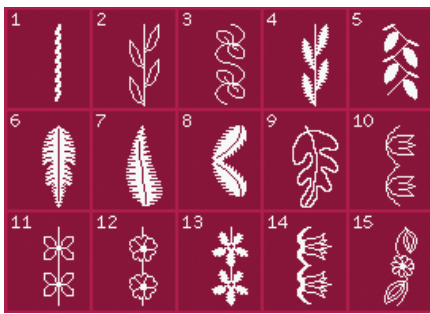

4.2 Decorative stitches -
Floral and ornamental stitches



4.2 Decorative stitches -
Floral and ornamental stitches

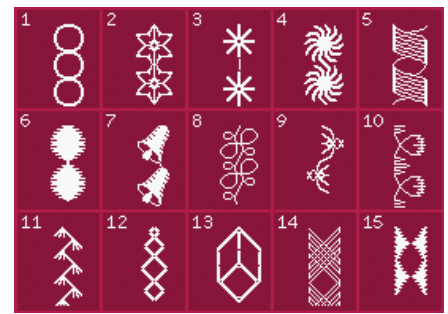

4.3 Decorative stitches -
Art stitches



4.3 Decorative stitches -
Art stitches

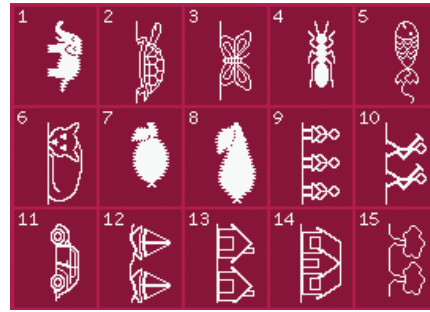

4.4 Decorative stitches -
Fun stitches

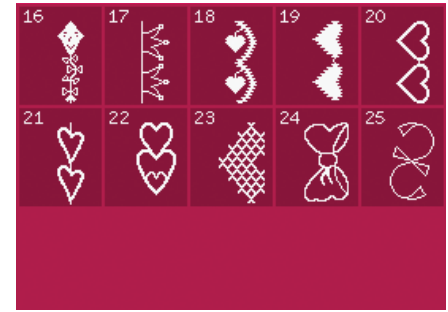

4.4 Decorative stitches -
Fun stitches

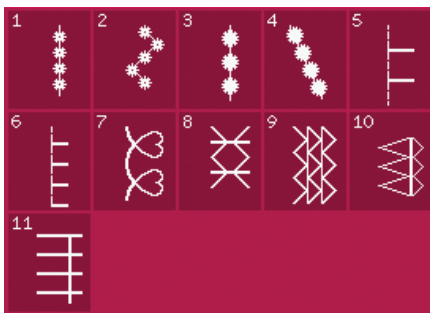

5.1 Sewing techniques -
Optional feet stitches

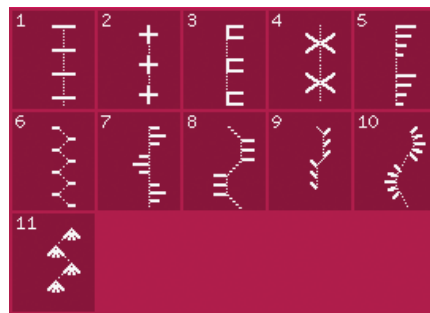

5.2 Sewing techniques -
Handlook quilt stitches

Alphabets

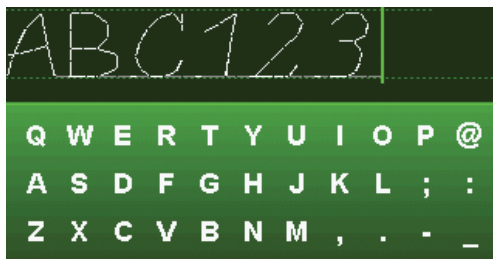

Comic



Script



Outline

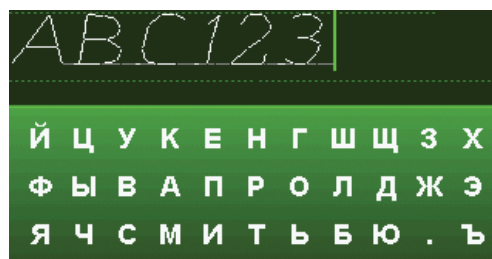

Cyrillic



Preparations 2

Unpacking

1. Place the box on a steady, flat surface. Lift the machine out of the box and remove the outer packaging and lift off the machine carrying case.
2. Remove all other packing material and the plastic bags.
3. Slide off the accessory tray and remove the styrofoam underneath the free arm.

Note: Styrofoam left in the accessory tray while sewing may affect stitch quality. The styrofoam is for packing purposes only and should be removed.

Note: Your creative™ 3.0 sewing and embroidery machine is adjusted to provide the best stitch result at normal room temperature. Extreme hot and cold temperatures can affect the sewn result.

Connecting the foot control cord

Among the accessories you will find the foot control cord. Connecting the foot control cord to the foot control is only necessary the very first time you are going to use the machine.

1. Take out the foot control cord. Turn the foot control over. Connect the cord to the socket inside the open space on the underside of the foot control as shown.
2. Push firmly to make sure it is properly connected.
3. Pull the cord into the slot to the left of the socket to ensure that the foot control will rest evenly on the floor.

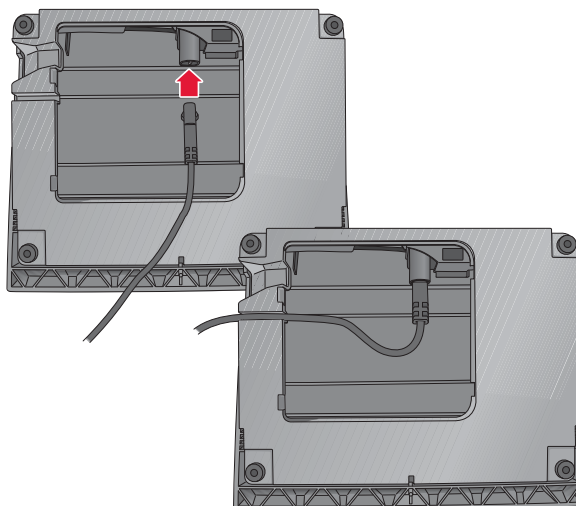

Connect the power cord and foot control

Note: Before plugging in the foot control, check to ensure that it is type "FR5" (see underside of foot control).

1. Connect the foot control cord to the front socket on the bottom right side of the machine (A).
2. Connect the power cord to the rear socket on the bottom right side of the machine (B). Plug the cord into a wall socket.
3. Press the I/O switch to "I" to turn on power and light (C).

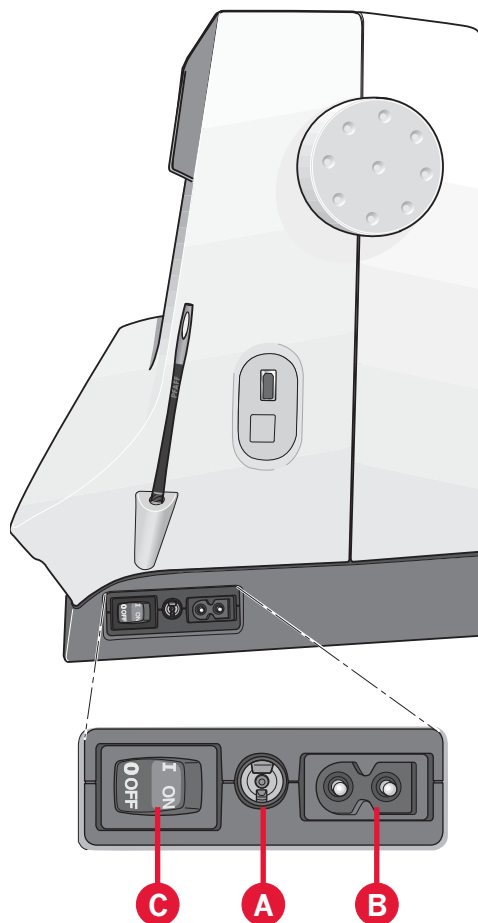

For the USA and Canada

This sewing machine has a polarized plug (one blade wider than the other). To reduce the risk of electric shock, this plug is intended to fit in a polarized outlet only one way. If the plug does not fit fully in the outlet, reverse the plug. If it still does not fit, contact a qualified electrician to install the proper outlet. Do not modify the plug in any way.

Pack away after sewing

1. Turn the main switch I/O to "O" (C).
2. Unplug the cord from the wall socket and then from the machine (B).
3. Unplug the foot control cord from the machine (A). Wind the foot control cord and place inside the open area on the underside of the foot control.
4. Place all accessories in the accessory tray. Slide the tray on to the machine around the free arm.
5. Place the foot control in the space above the free arm.
6. Put on the hard cover.

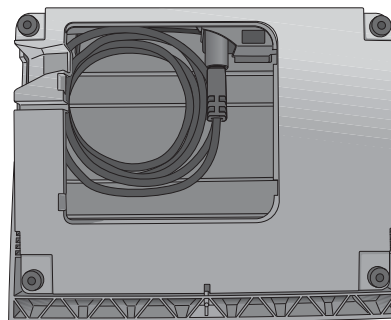

LED lights

Your machine has LED lights which distribute the light evenly over the sewing area and eliminates shadows.

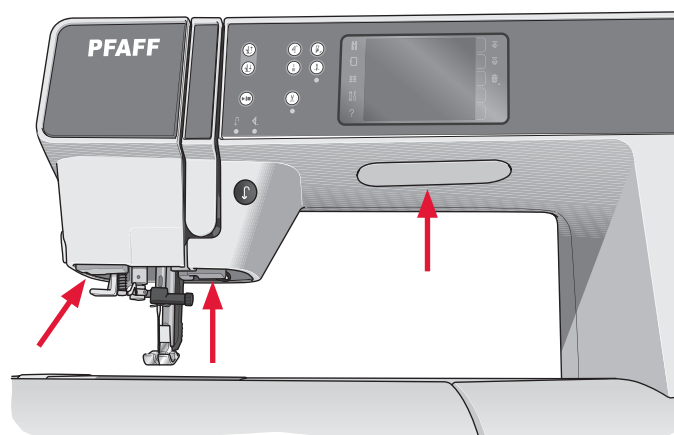

Free arm

To use the free arm, slide off the accessory tray. When attached, a hook keeps the accessory tray locked to the machine. Remove the tray by sliding it to the left.

Thread cutter

To use the thread cutter, pull the thread from back to front as shown.

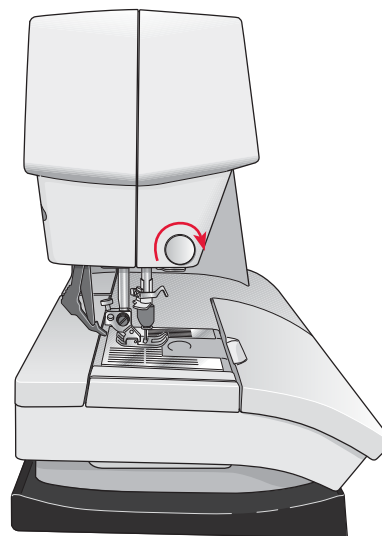

Spool pins

Your machine has two spool pins, a main spool pin and an auxiliary spool pin. The spool pins are designed for all types of thread. The main spool pin is adjustable and can be used both in a horizontal position (the thread reels off the spool) and a vertical position (the thread spool rotates). Use the horizontal position for normal threads and the vertical position for large spools or specialty threads.

Horizontal position

Place a spool cap and the thread spool on the spool pin. Make sure that the thread reels off the spool counter clock-wise and slide on a second spool cap.

Note: Not all thread spools are manufactured in the same way. If you experience problems with the thread, turn it in the opposite way or use the vertical position.

Use a spool cap slightly larger than the thread spool. For narrow thread spools, use a smaller spool cap in front of the spool. For large thread spools, use a larger spool cap in front of the spool.

The flat side of the spool cap should be pressed firmly against the spool. There should be no space between the spool cap and the thread spool.

Vertical position

Raise the spool pin to the vertical position. Slide on the large spool cap and place a felt pad under the thread spool. This is to prevent the thread from reeling off too fast.

Do not place a spool cap on top of the spool pin as that would prevent the spool from rotating.

Note: When the spool pin is used in the vertical position, the thread tension might need to be adjusted manually.

Auxiliary spool pin

The auxiliary spool pin is used when winding a bobbin thread from a second spool of thread or for a second spool when sewing with a twin needle.

Raise the auxiliary spool pin. Slide on a large spool cap and place a felt pad under the thread spool.

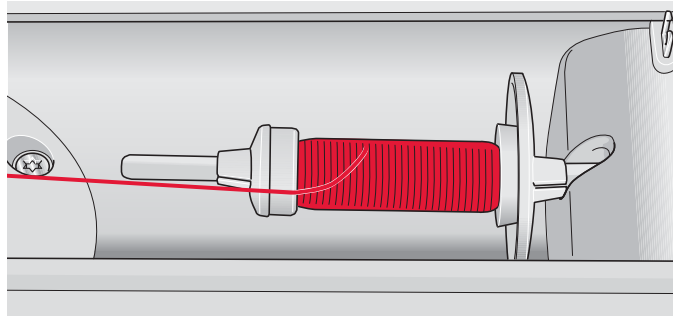

Small spool cap

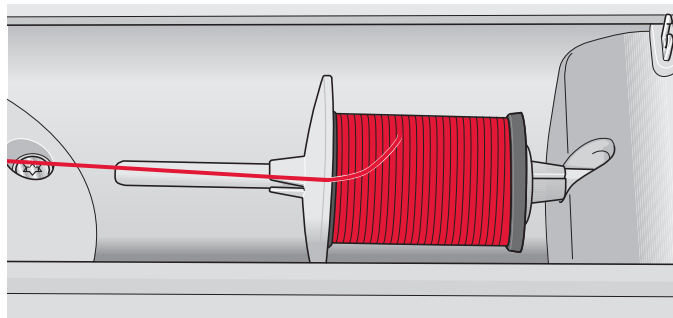

Large spool cap

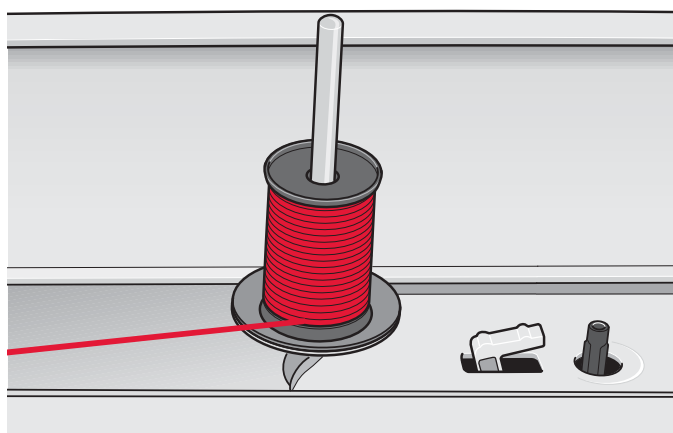

Main spool pin in vertical position

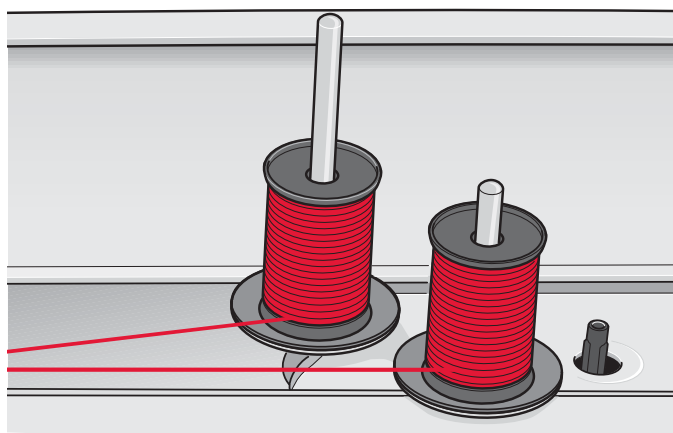

Auxiliary spool pin and main spool pin in vertical position.

Threading the machine

Make sure that the presser foot is raised and the needle is in the up position.

1. Place the thread on the spool pin and fit a spool cap of the right size.

Note: Hold thread with both hands to prevent it from slacking while threading. This ensures that the thread will be positioned properly in the threading path.

2. Pull the thread into the thread guide by pulling it from the front to the back (A). Make sure the thread clicks into place. Then pull the thread underneath the bobbin winder thread guide (B) on the pre-tension disc (C).
3. Thread down through the right-hand threading slot and then upwards through the left-hand threading slot.
4. Bring the thread from the right into the take-up lever (D) and down in the left-hand threading slot to the needle thread guide (E).
5. Thread the needle.

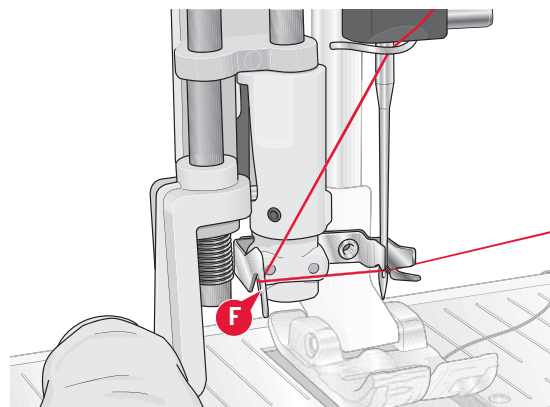
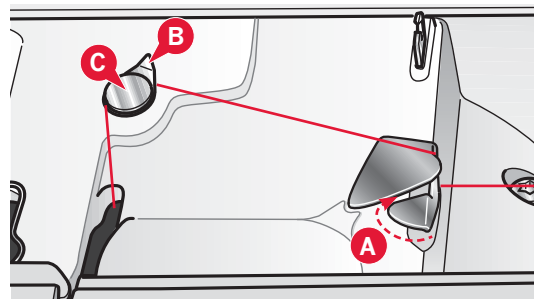
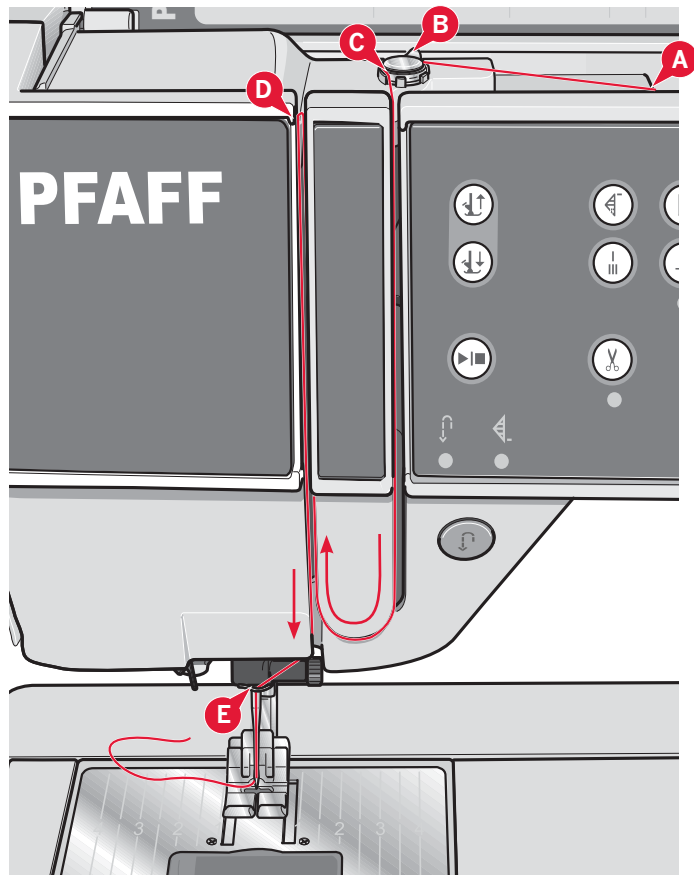

Needle threader

The needle threader allows you to thread the needle automatically. The needle must be in the up position to use the built-in needle threader.

1. Lower the presser foot.
2. Use the handle to pull the needle threader all the way down. The threader hook (G) swivels through the needle eye.
3. Place the thread from the back over the hook (F) and under the thread hook (G).
4. Let the needle threader gently swing back. The hook pulls the thread through the needle eye and forms a loop behind the needle. Pull the thread loop out behind the needle.

Note: The needle threader is designed to be used for size 70-120 needles. You cannot use the needle threader for size 60 needle or smaller, the wing needle, twin needle or triple needle. There are also some optional accessories that require manual threading of the needle.

The bobbin cover can be used as a magnifying glass.

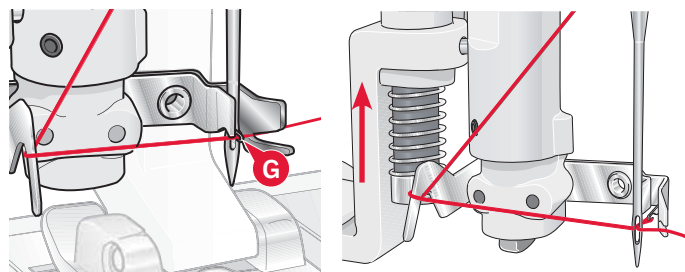

Threading for twin needle

Replace the sewing needle with a twin needle. Make sure that the presser foot is raised and the needle is in the up position.

1. Place the thread on the spool pin and fit a spool cap of the right size. Raise the auxiliary spool pin. Slide on a large spool cap and a felt pad. Place the second thread on the spool pin.

Note: Hold threads with both hands to prevent them from slacking while threading. This ensures that the threads will be positioned properly in the threading path.

2. Pull the threads into the thread guide by pulling them from the front to the back (A). Make sure the threads click into place. Then pull the threads underneath the bobbin winder thread guide (B) on the pre-tension disc (C).
3. Thread down through the right-hand threading slot and then upwards through the left-hand threading slot. Make sure that you pass one thread to the left and one thread to the right sides of the tension disk (F).
4. Bring the threads from the right into the take-up lever (D) and down in the left-hand threading slot. Make sure that one thread is inside the needle thread guide (E) and the other one outside. Make sure that the threads do not become twisted together.
5. Thread the needles.

Note: Activate twin needle and select the correct twin needle width in the Settings menu. This will limit the width of all stitches for that needle size to prevent damage to presser foot and needle.

Note: The weight and irregular surface of specialty threads such as metallic increases the amount of friction on the thread. By reducing the tension, the risk of needle breakage is prevented.

Note: Do not use asymmetrical twin needles (G), since it may damage your sewing machine.

Thread sensor

If the upper thread breaks or bobbin thread runs out, the machine stops and a pop-up appears on the screen.

If upper thread breaks: Re-thread the machine and touch OK on the pop-up. If bobbin thread runs out: replace with a wound bobbin and continue sewing.

Note: When the bobbin thread is almost empty, the bobbin thread low pop-up appears on the screen. You can continue sewing without closing the pop-up before the bobbin thread runs out completely.

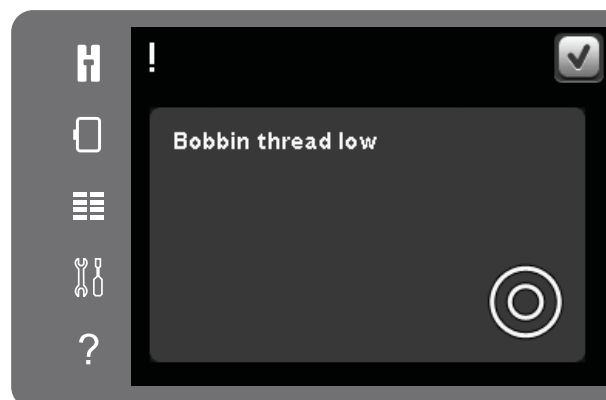
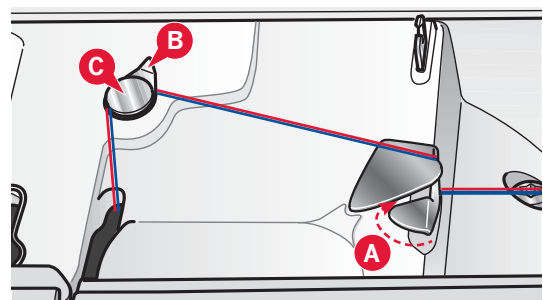
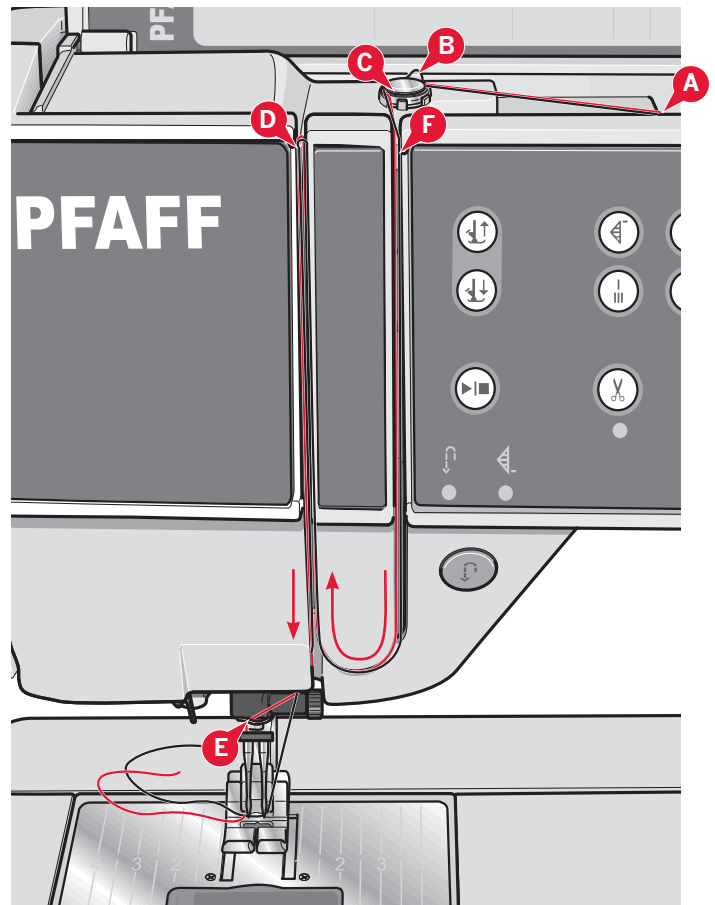

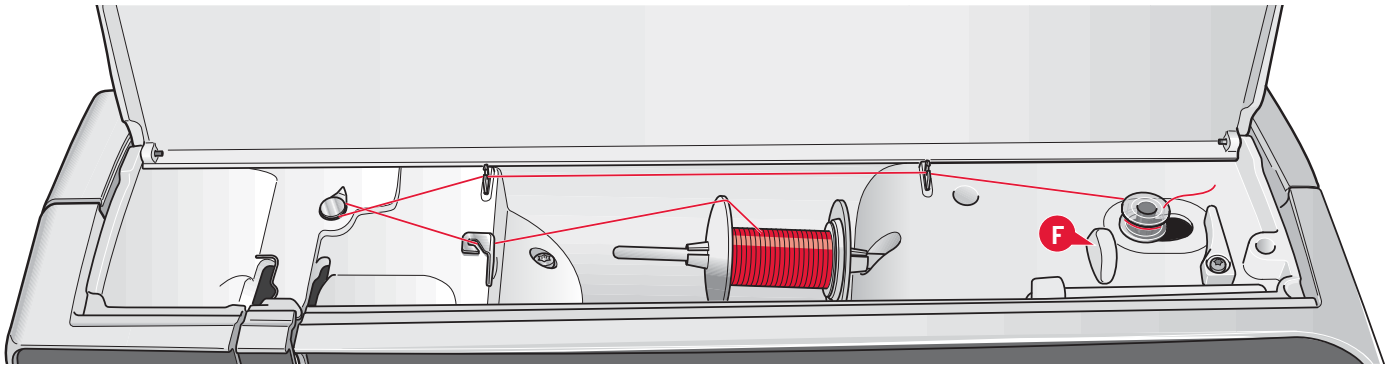

Bobbin winding

Winding from horizontal position

1. Place an empty bobbin on the bobbin winder spindle, with the logo facing up. Use only the original PFAFF® bobbins approved for this model.
2. Place the thread spool on the spool pin in horizontal position. Slide a spool cap tightly against the spool.
3. Place the thread into the thread guide (A) from front to back. Pull the thread counter-clockwise above the bobbin winder thread guide (B) and then through the bobbin thread guides (C) at the rear.

Note: Make sure the thread is pulled securely inside the pre-tension device for correct thread tension.

4. Thread through the slot in the bobbin (D) from the inside to the outside.
5. Push the bobbin winder spindle to the right to wind. A pop-up appears on the screen to inform you that bobbin winding is active. To adjust winding speed, use the slider in the pop-up. Start bobbin winding by pressing the foot control or touch the start/stop.

When the bobbin is full, it will stop winding. Release the foot control or touch start/stop to stop the bobbin winder motor from running. Move the bobbin winder spindle to the left and the pop-up will close. Remove the bobbin and cut the thread using the bobbin thread cutter (F).

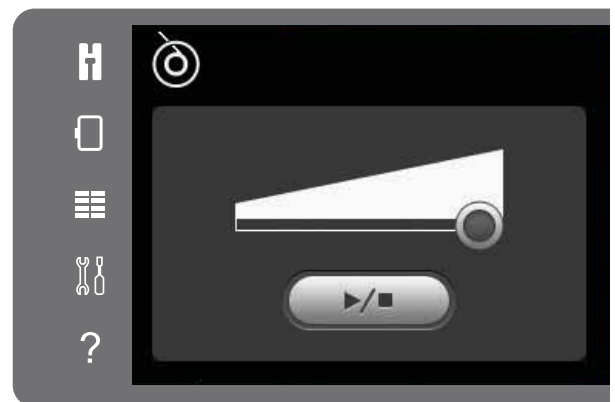
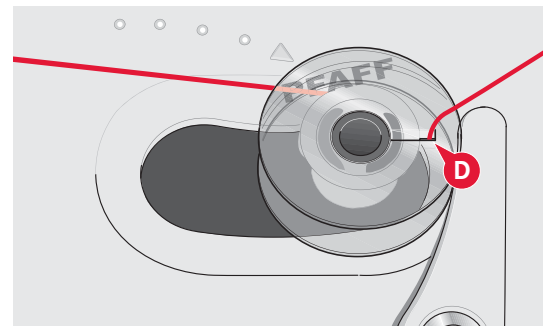
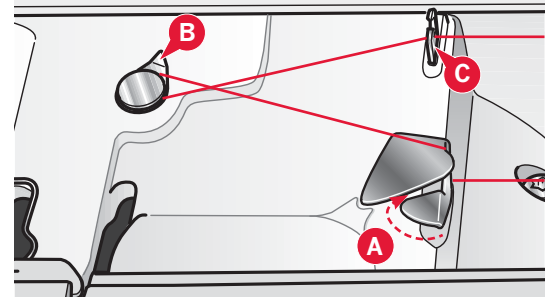

Winding while threaded

Make sure that the presser foot and the needle are in the up position. To prevent the needle from bending, pull the thread out of the needle.

Bring the thread up from the needle thread guide (E), upward through the left-hand threading slot and through the bobbin thread guides (C). Then follow step 4 and 5 above.

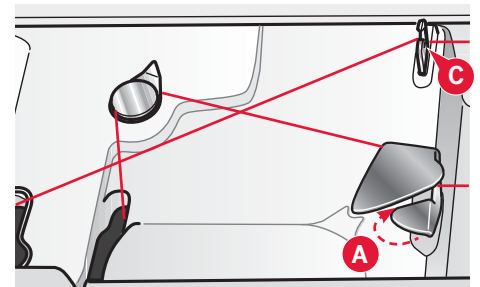
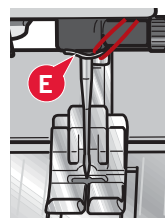

Inserting the bobbin

1. Remove the bobbin cover by sliding it towards you.
2. Place the bobbin in the bobbin case with the logotype facing up and the thread unreeling from the left of the bobbin. The bobbin will then rotate counter-clockwise when you pull out the thread.
3. Place your finger on the bobbin to keep it from turning as you pull the thread firmly to the right and then to the left into the tension spring (A) until it "clicks" into place.
4. Continue threading around (B) and to the right of the thread cutter (C). Replace the cover. Pull the thread to the left to cut.

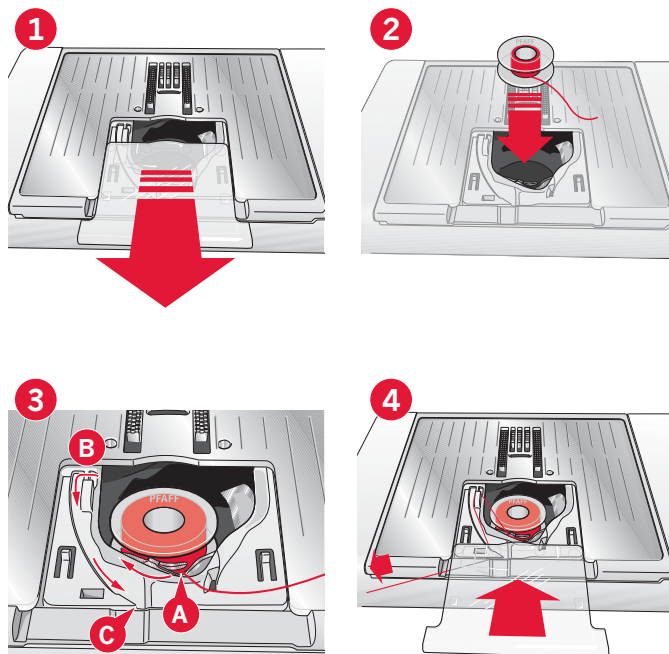

IDT™ system (Integrated Dual Feed)

For sewing any fabric precisely the PFAFF® creative™ 3.0 sewing and embroidery machine provides the ideal solution: the integrated dual feed, IDT™ system. As on industrial machines, the IDT™ system feeds the fabric from the top and bottom at the same time. The material is fed precisely, eliminating puckering on seams in light weight fabrics such as silk and rayon. The dual feed action of the IDT™ system prevents layers from shifting while sewing, keeping quilt layers aligned and ensuring a more perfect match when sewing plaid or striped fabrics.

Engaging the IDT™ system

Important: For all work with the IDT™ system use presser feet with the center back cut-out (A).

Raise the presser foot. Press the IDT™ system down until it engages.

Disengaging the IDT™ system

Raise the presser foot. Hold the IDT™ system with two fingers at the ribbed ankle. Pull the IDT™ system down, then pull it away from you to release the IDT™ system slowly upward.

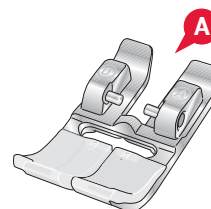
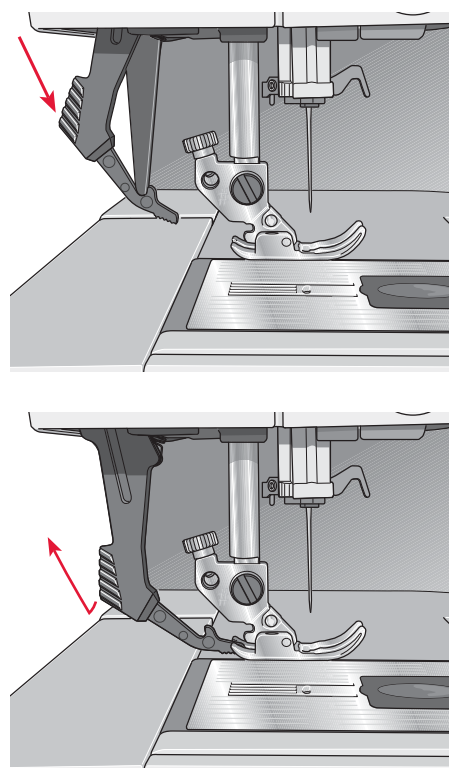

Changing the presser foot

Remove presser foot

Press the presser foot downwards until it disengages from the presser foot holder.

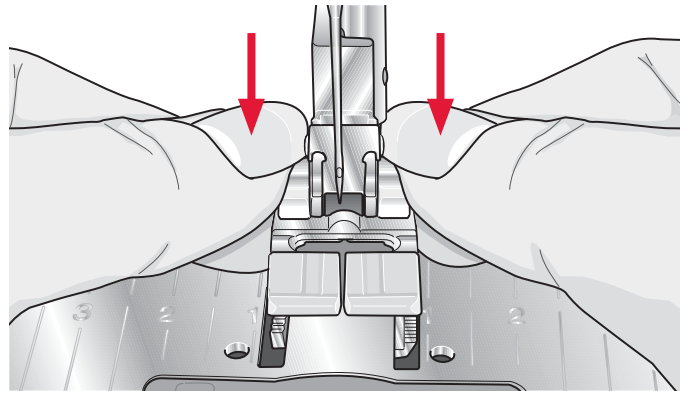

Attach presser foot

Line up the pins on the foot with the gap underneath the presser foot holder. Press upwards until the foot snaps into place.

You can also use the presser foot up/down buttons to raise or lower the presser foot holder. Place the presser foot under the presser foot holder, so that the pins of the foot snap onto the presser foot holder when lowered.

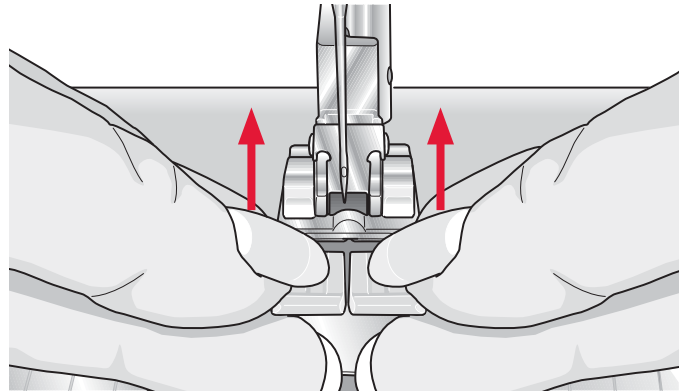

Changing the needle

1. Use the hole in the multi-purpose tool to hold the needle.
2. Loosen the needle screw.
3. Remove the needle.
4. Insert the new needle, using the multi-purpose tool. Push the new needle upwards with the flat side away from you until it will go no further.
5. Tighten the needle screw as tight as it will go.

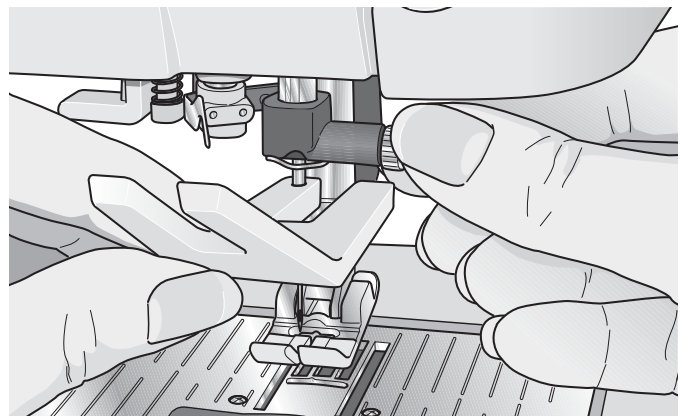

Lowering feed dogs

You can lower the feed dogs by moving the switch on the front of the sewing machine to the left. Move the switch to the right if you wish to raise the feed dogs.

When embroidering the feed dogs are lowered automatically as the embroidery unit is connected. When the embroidery unit is removed, the feed dogs are raised automatically when you start sewing.

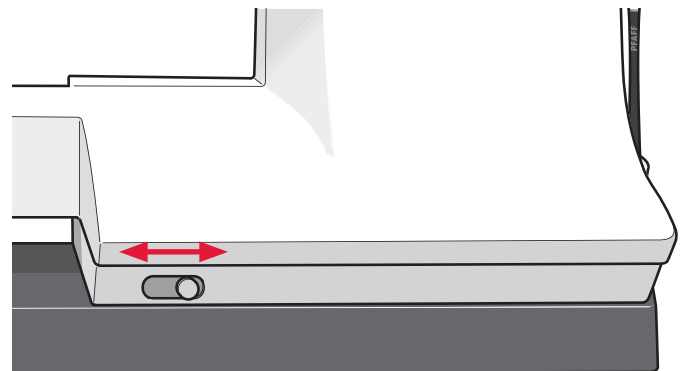

Needles

The sewing machine needle plays an important role in successful sewing. Use only quality needles. We recommend needles of system 130/705H. The needle package included with your machine contains needles of the most frequently used sizes.

Universal needle (A)

Universal needles have a slightly rounded point and come in a variety of sizes. For general sewing in a variety of fabric types and weights.

Stretch needle (B)

Stretch needles have a special scarf to eliminate skipped stitches when there is a flex in the fabric. For knits, swimwear, fleece, synthetic suedes and leathers.

Embroidery needle (C)

Embroidery needles have a special scarf, a slightly rounded point and a slightly larger eye to avoid damage to thread and materials. Use with metallic and other specialty threads for embroidery and decorative sewing

Denim needle (D)

Denim needles have a sharp point to penetrate tightly woven fabrics without deflecting the needle. For canvas, denim, microfibers.

Wing needle (E)

The Wing needle has wide wings on the side of the needle to poke holes in the fabric when sewing entredeux and other hemstitches on natural fiber fabrics.

Note: Change the needle often. Always use a straight needle with a sharp point (F).

A damaged needle (G) can cause skipped stitches, breakage or snapping of thread. A damaged needle can also damage the needle plate.

Do not use asymmetrical twin needles (H), since it may damage your sewing machine.

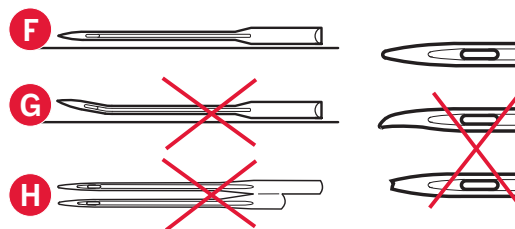
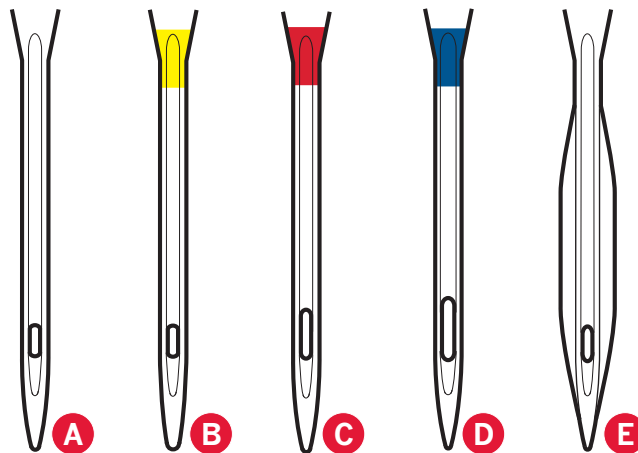

Threads

There are many threads on the market today developed for different purposes.

All purpose sewing thread

All purpose sewing thread is made of synthetic, cotton or cotton covered polyester. This type of thread is used for sewing garments and projects.

Embroidery thread

Embroidery thread is made of various fibers: rayon, polyester, acrylic or metallic. These threads create a smooth glossy appearance for embroidery and other decorative stitching.

When embroidering, use embroidery bobbin thread because it is a fine weight and will not build up under embroidery.

Note: When using a metallic or a flat film thread for embroidering, you may need to use a needle with a larger eye and lower the embroidery speed. Thread the sewing machine with the spool in the vertical position.

Transparent thread

Transparent thread, also called monofilament thread, is single clear synthetic thread. It is used for quilting and other decorative sewing. Thread the sewing machine with the spool in the vertical position. When winding a bobbin, wind at slow speed and wind the bobbin half full.

Note: Some fabrics have excess dye which can cause discoloration on other fabrics or on your sewing machine. This discoloration may be very difficult or impossible to remove.

Fleece and denim fabric, especially red and blue, often contain excess dye.

If you suspect that your fabric/ready-to-wear garment contains a lot of excess dye, always pre-wash it before sewing/embroidering to prevent discoloration of your machine.



Stabilizers

Tear-away stabilizers

Tear-away stabilizers are used with stable woven fabrics. Place underneath fabric for decorative stitching or hoop with the fabric when embroidering. Tear away excess stabilizer after stitching.

Iron-on tear-away

Iron-on tear-away is a totally stable stabilizer that has a slick side that will iron on to fabric. It is recommended for knits and all unstable fabrics. Fuse it to the wrong side of the fabric before decorative stitching or hooping. Tear away excess stabilizer after stitching.

Cut-away stabilizer

Cut-away stabilizer does not tear so the excess has to be cut away. It is recommended for knits and all unstable fabrics, especially for hoop embroidery.

Water soluble stabilizer

Water soluble stabilizer is placed on top of the fabric when embellishing/embroidering napped and looped fabrics such as terry cloth. When embroidering cutwork, use it underneath the fabric. Place your work in water to dissolve the excess stabilizer. It is available in different thicknesses.

Disintegrating stabilizer

Disintegrating stabilizer is a stable, loosely woven fabric that is used for techniques such as cutwork and to crochet off the fabric edge. The stabilizer disappears with heat.

Sticky stabilizer

Sticky stabilizer is used for hoop embroidery when the fabric is too delicate or too small to be hooped. Hoop the sticky stabilizer with the paper side up. Remove the paper and stick the fabric onto the sticky surface. Tear away sticky stabilizer after stitching.

USB port

Your machine has a USB port to connect your USB embroidery stick.

Note: Make sure that the USB stick you use has the format FAT32.

USB embroidery stick

Delivered with your machine is an USB embroidery stick. Use the stick to store designs and embroidery fonts.

Connect to and remove from USB port

Insert the USB embroidery stick in the port. The USB plug can only be inserted one way – do not force it into the port!

To remove, carefully pull the USB embroidery stick out straight.

Using the USB embroidery stick

A light at the end of the stick indicates that the USB embroidery stick is plugged in correctly. When loading from the USB embroidery stick, the light flashes.

Note: Do not remove the USB embroidery stick while the light is flashing, as this can damage the files on your USB embroidery stick.

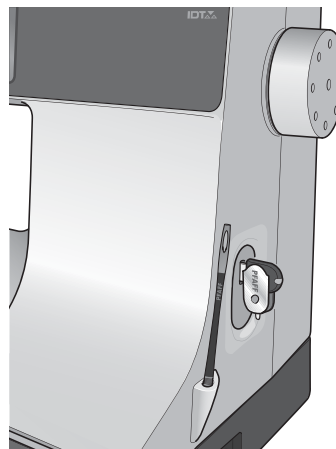
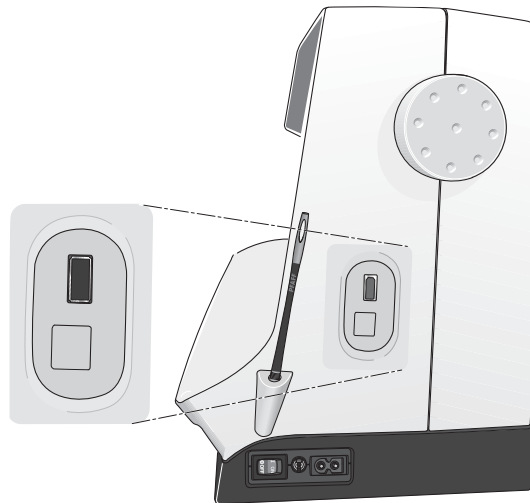

Note: The USB embroidery stick provided with the machine can be left in the machine when putting on the hard cover. Make sure that the cover of the USB stick is turned downwards.

Complimentary software (PC)

A PC software package is available for your PFAFF® creative™ 3.0 sewing and embroidery machine. It adds following features:

- QuickFont program to create unlimited number of embroidery fonts from most TrueType® and OpenType® fonts on your computer.
- Handling of embroidery designs: viewing designs as thumbnail images, reading different embroidery file formats, add trim commands and more.

Go to PFAFF® website at www.pfaff.com and look for Embroidery Machines Support and download the software. When you install you will be asked for Installation Code. Enter number:

8200

More information and detailed installation instructions are available on the download page.

How to update your machine

Be sure to consult the web site at www.pfaff.com and/or your local authorized PFAFF® dealer for updates and upgrades for your machine and owner's manual.

Updating instructions

- Go to the PFAFF® website at www.pfaff.com and find your sewing and embroidery machine. Here you will find updates available for your machine.
- Download and unzip the update software to your USB embroidery stick.
- Make sure that your machine is turned off. Connect the USB embroidery stick loaded with the new software version to the USB port on your machine.
- While pressing and holding the reverse button, turn your machine on.
- The update starts automatically and you can release the reverse button when the progress bar appears.

Note: It might take up to one minute before the progress bar appears and you can release the reverse button.

- When the update is complete the machine will restart automatically. Check the software version number in the settings menu.

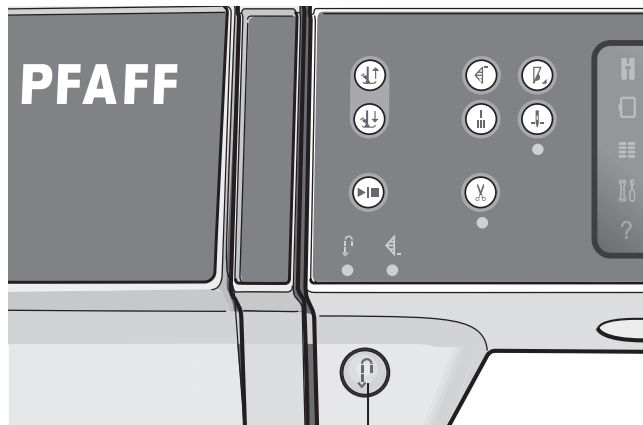

Reverse button





Machine settings & buttons 3

Touch screen

The touch screen on your PFAFF® creative™ 3.0 sewing and embroidery machine is very easy to work with - just touch it with your stylus or your finger tip to make your choices. Below describes the touch screen outside the PFAFF® creative™ Color Touch Screen. This touch area will not change its appearance when switching between different modes.

Touch screen - overview



Sewing and embroidery mode

Switch between sewing mode and embroidery mode by touching one of these icons.

Selection menu

Touch this icon to open the selection menu. In sewing mode you can select stitches, stitch fonts, open personal files or an USB device. In embroidery mode you can select designs, embroidery fonts, open personal files or an USB device.

Settings menu

Touch this icon to open the settings menu. In this view you can change default settings and make manual adjustments to the machine settings, sewing settings and embroidery settings. You will also find machine information in the settings menu.

Quick help

Your machine has built-in quick help, which gives you instant information about everything you see on the touch screen. Touch the quick help icon to activate quick help. A question mark will appear on the PFAFF® creative™ Color Touch Screen. Touch any icon, text or area on the touch area that you want information about. A pop-up gives a short explanation. Touch OK in the pop-up to exit quick help.

Mirror side to side

In sewing mode you can mirror a stitch or sequence horizontally by touching the mirror side to side icon. In embroidery mode a design will be mirrored horizontally when touching the icon.

Mirror end to end

In sewing mode you can mirror a stitch or sequence vertically by touching the mirror end to end icon. In embroidery mode a design will be mirrored vertically when touching the icon.

Delete

Touch the delete icon when you want to delete a stitch, sequence, design or folder. Long touch delete in embroidery mode to delete all designs in the embroidery field. If a folder is deleted, all files within the folder are deleted as well. To delete all files and folders in the current folder, long touch the delete icon.

Note: You cannot delete built-in stitches, fonts and designs.

Settings menu

In the settings menu, you can change default settings and make manual adjustments to the machine settings, sewing settings and embroidery settings.

Touch the icons to activate a function or open a list of choices. The settings are saved even after turning off the machine.

Machine settings

Language

Touch the language icon to view the available languages. Select your desired language from the list by touching it.

Audio repeat

When active, the signal for warnings or attention pop-ups is repeated in intervals until it is cancelled.

Lock screen

If there is a possibility of bumping into the screen and changing the stitch, embroidery or setting while sewing or embroidering, it is easy to lock the screen.

When selected, the screen will become locked ten seconds after the last touch. The screen will be locked until you unlock it by touching OK.

Calibrate touch screen

The touch screen can be calibrated for the individual user.

Touch the calibrate touch screen icon to open a special view for PFAFF® creative™ Color Touch Screen calibration. Follow the instructions on the screen to calibrate.

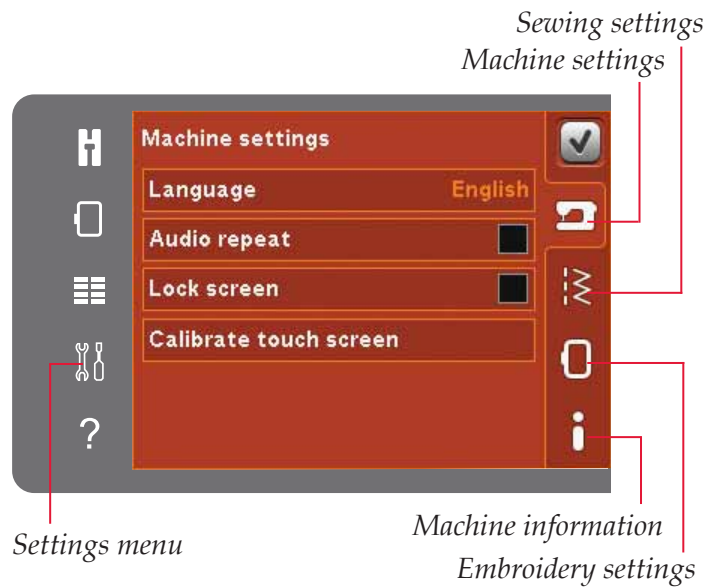

Pop-up for language selection

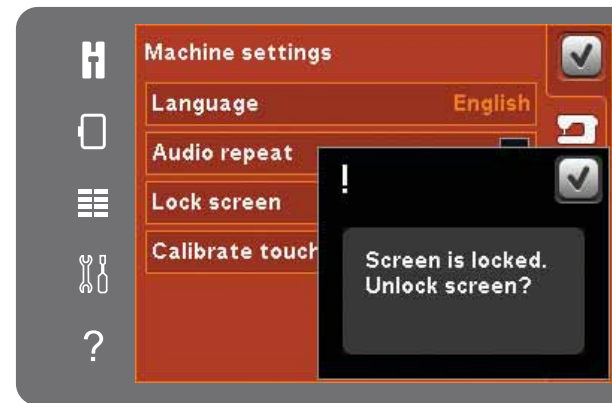

Pop-up for lock screen

Sewing settings

Twin needle

Touch the twin needle icon to open a list for twin needle width selections. When a twin needle size is selected, the width of all stitches is limited for that needle size to prevent needle breakage. The setting is kept until you deselect the twin needle width.

The stitch width of the selected stitch will automatically be adjusted to fit the twin needle. If you select a stitch that is too wide for the twin needle size, a warning pop-up will appear. Select "off" in the twin needle list to deselect twin needle and go back to normal sewing.

Stitch width safety

Select this function when using the straight stitch needle plate or a straight stitch presser foot to lock the needle in center position for all stitches. Stitch width safety will prevent damage to the needle and/or presser foot.

When turning on the machine with this setting activated and for every stitch selection that is not a straight stitch, a pop-up informs you that it is set to straight stitch. Deselect stitch width safety to go back to normal sewing.

Note: Twin needle and stitch width safety cannot be used at the same time.

Presser foot pressure

In some cases, you might need to adjust the presser foot pressure. Specialty techniques or thick fabric may require an adjustment. The higher the number the more pressure on the fabric.

Automatic presser foot lift

When selected, the automatic presser foot lift is activated. The presser foot will raise to pivot height for example when stopping with the needle in the down position. When deselected, the presser foot will stay lowered even if the machine stops with the needle in down position.

Thread snips for sewing

When selected, the automatic thread snips are activated. The threads are cut automatically and the presser foot raises when sewing is complete, e.g. a buttonhole. When deselected, no automatic thread snip will be performed.

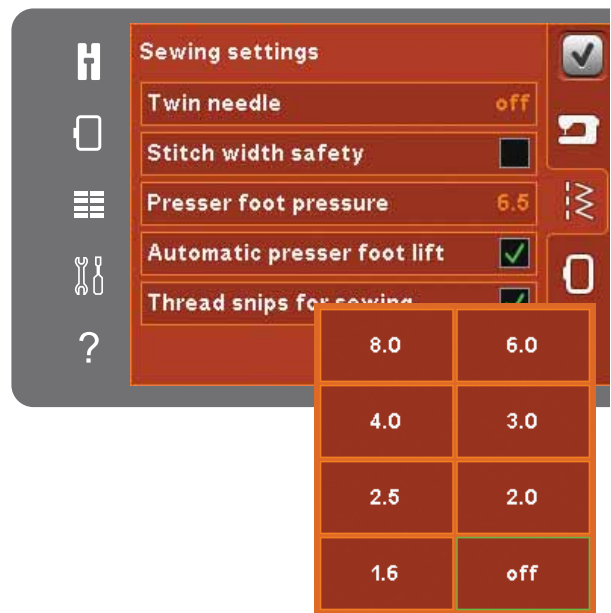

List of twin needle width



Stitch width safety symbol

Twin needle symbol

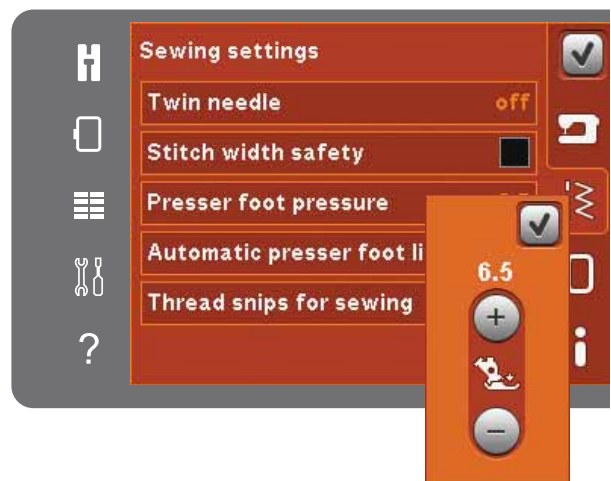

Presser foot pressure control

Embroidery settings

Presser foot height

Adjust the height of the presser foot in Embroidery stitch-out mode. Use the + and - icons to either raise or lower the height of the presser foot.

Some embroideries may build up under the presser foot. If there is not enough space between the presser foot and the embroidery, the top thread will form loops on the underside of the embroidery. Increase the presser foot height in small steps until the embroidery moves freely under the presser foot.

Note: Since the Dynamic Spring Foot 6D (optional 820991-096) measures the fabric thickness, the option to adjust presser foot height in embroidery is only available if Dynamic Spring Foot 6D for embroidery is deselected.

Dynamic spring foot 6D

When embroidering, use the optional Dynamic spring foot 6D (part number 820991-096, available at your authorized PFAFF® dealer). Activate the "Dynamic spring foot 6D" function.

If using another type of embroidery foot, e.g. Embroidery/Sensormatic free-motion foot 6A, deactivate Dynamic spring foot 6D in the settings menu.

Cut jump stitches

Your machine features the automatic function Cut jump stitches. This function saves you time trimming after the embroidery is completed. When Cut jump stitches is selected your machine will trim the top jump stitch thread and pull the thread end to the underside of the fabric as you embroider. When deselected, the machine will stop after a few stitches in every color change to let you cut the threads manually.

Note: Your machine will also cut the thread after you have changed to a new color. Hold the thread end when you start embroidering again, so that you can easily remove the thread end when cut.



Designs marked with this symbol are programmed for Cut jump stitches. Cut jump stitches commands can be added to any design using the software package downloaded via PFAFF® website (see page 2:12).

Thread snips for embroidery

Thread snips for embroidery is automatically activated by default. This function automatically cuts the threads at color changes or when an embroidery is finished.

Machine information

The machine information tab contains the software version, memory usage in machine and license information.



Presser foot height control

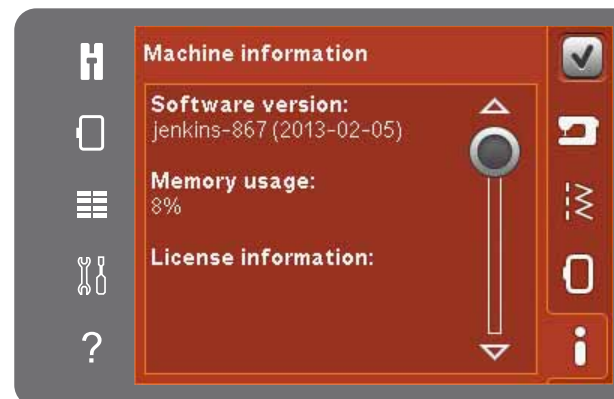

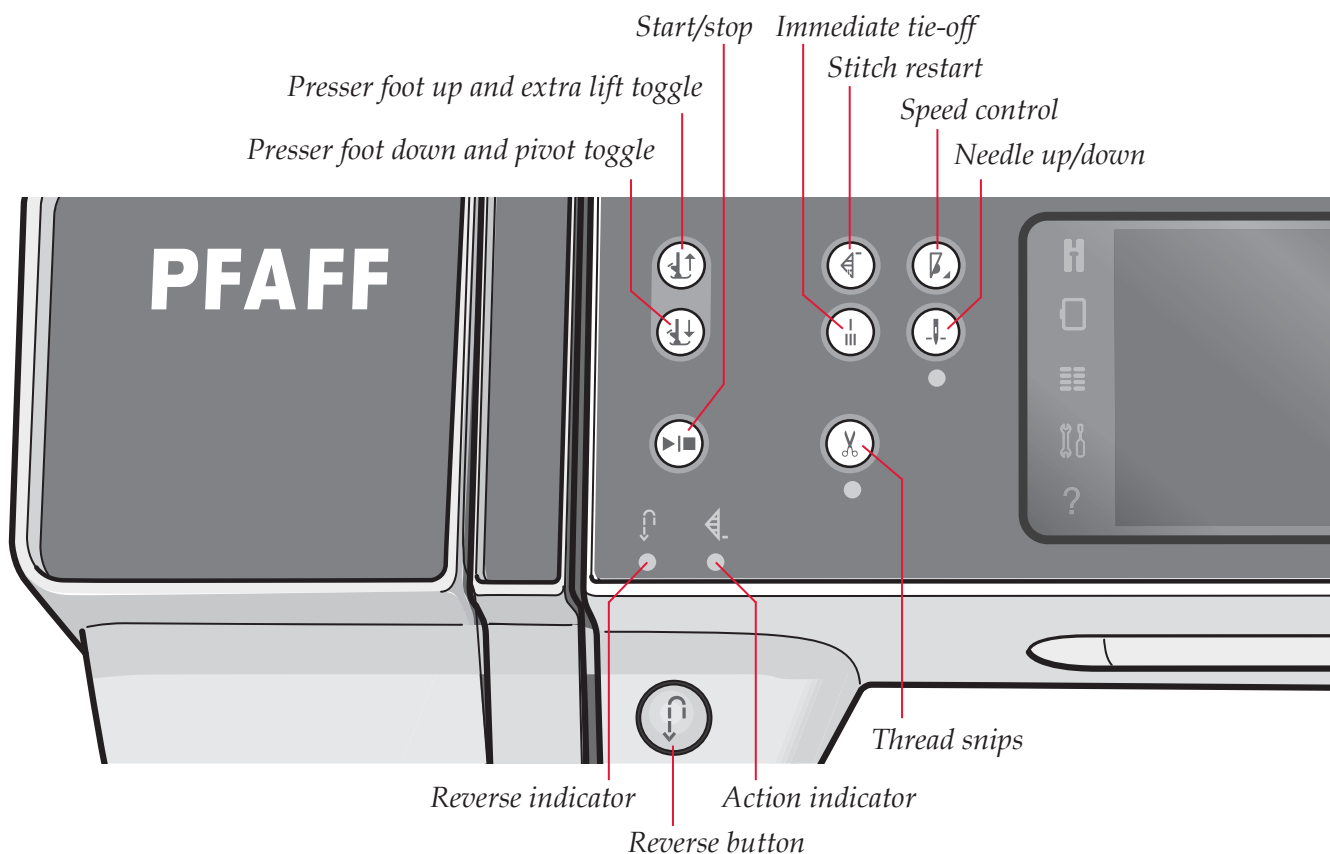

Buttons and indicators

Presser foot up and extra lift toggle

Touch this button to raise the presser foot. Touch this button to raise the presser foot. Press the button once more and the presser foot will raise to extra lift position and the needle will raise to up position.

Presser foot down and pivot toggle

Touch this button to lower the presser foot completely. Press the button once more to raise the presser foot to pivot height. The presser foot is lowered automatically when you start to sew.

Stitch restart

When you have stopped sewing in the middle of a stitch, press stitch restart to return to the beginning of the stitch again without having to reset any special settings you have made.

If pressing the stitch restart button while sewing, the stitch will be finished and the machine will then stop. You can also use stitch restart to go back to the beginning of an embroidery.

Speed control

This function enables you to easily reduce the sewing speed. Just touch the speed control button to reduce the speed. To return to normal speed, deselect the button.

You can change the speed limit on your machine. Long touch the speed control button to open a pop-up. Set desired speed limit using the slider, then close the pop-up. The next time you touch the speed control button, the speed will be reduced to the limit you have chosen. The limit will be shown at the top left corner, either in sewing mode or embroidery mode. You can sew without closing the pop-up.

Immediate tie-off

Press immediate tie-off while sewing and your machine sews a few tie-off stitches and stops automatically.

By touching the tie-off button once more while the action indicator is lit, the function can be turned off.

The tie-off function can be programmed, see page 4:10.

Needle up/down

Press this button to move the needle up or down. The setting of the needle stop position is changed at the same time. When needle down is activated, the indicator underneath the button is lit, the needle will stop in the down position and the presser foot will raise to pivot height.

You can also tap the foot control to raise or lower the needle.

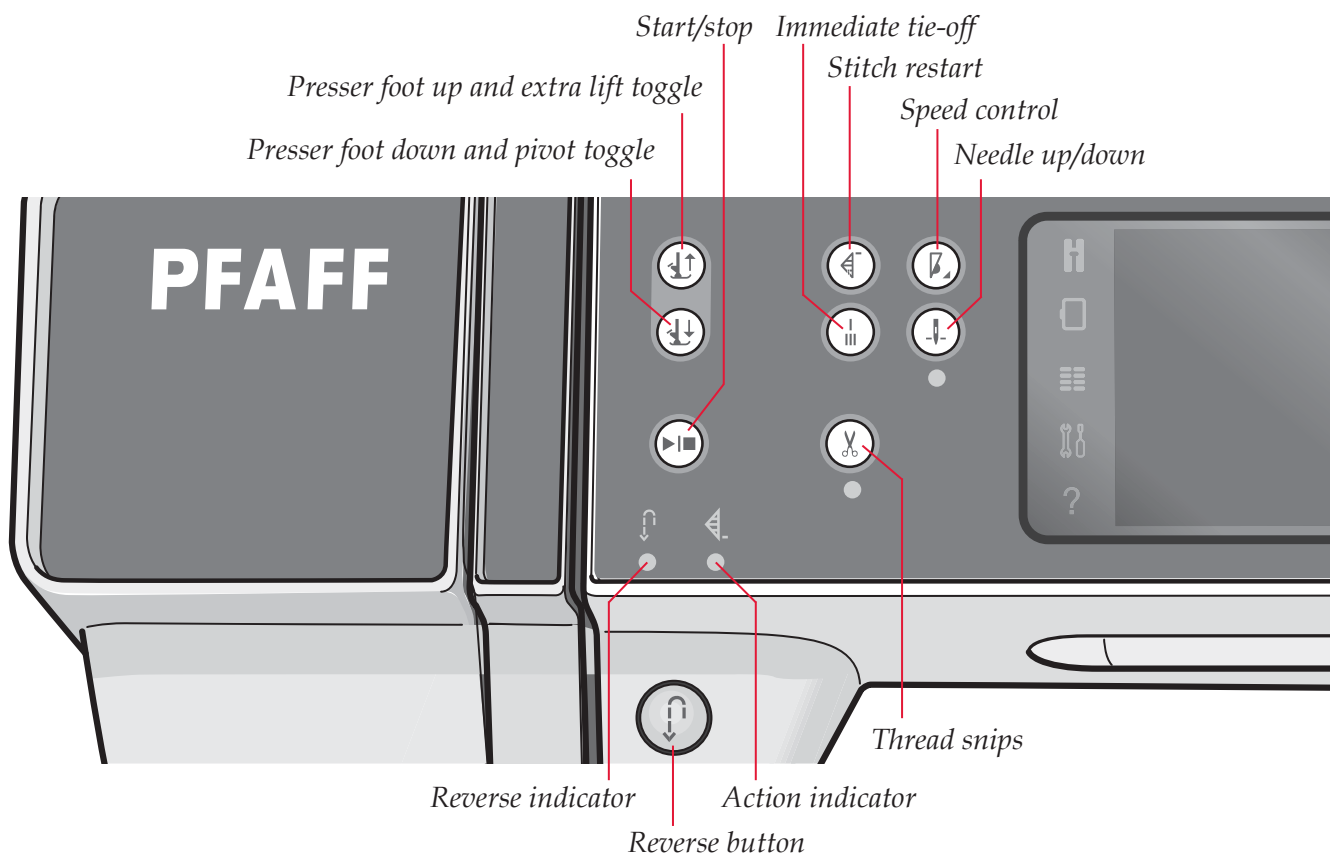

Start/stop

Press this button to start or stop the machine without using the foot control. Press the button once to start and press it again to stop.

Thread snips

Press to cut both needle and bobbin thread immediately.

If pressing this button while sewing, the machine will complete the stitch and cut the threads before the needle moves to the start position of the next stitch. Your machine ties off the thread, cuts the needle and bobbin threads and raises the presser foot and the needle.

The thread snips function can be programmed, see page 4:10.

Note: Threads are cut automatically when buttonholes are sewn with the Sensormatic buttonhole foot.

The presser foot will not raise after thread snips if automatic presser foot lift has been deactivated in the settings menu.

Thread snips performed by the machine can be cancelled in the settings menu.

In embroidery mode the threads are cut and the presser foot raised. The needle thread only cuts automatically at the color change. When the design is finished both needle and bobbin threads are cut automatically.

Reverse button

For permanent reverse, press the button once before starting to sew. The reverse indicator will be lit and the machine sews in reverse until you press the button again to cancel. If you press the reverse button while sewing, the machine sews in reverse for as long as you keep the button pressed. The reverse indicator is lit when the reverse button is pressed.

Reverse is also used when sewing manual buttonholes, darning stitches, programmed tie-off end and tapering stitches.

Reverse indicator

The reverse indicator will be lit when pressing the reverse button to sew in reverse. It is also lit while sewing permanent reverse.

Action indicator

The action indicator is lit to indicate that an action is to be done, for example performing tapering. The indicator stays lit until the action is done.

Common icons

There are some icons and functions that are frequently used on the screen. The most common are described below.

Scroll bar

Touch and drag the scroll bar to scroll up/down for more available options.

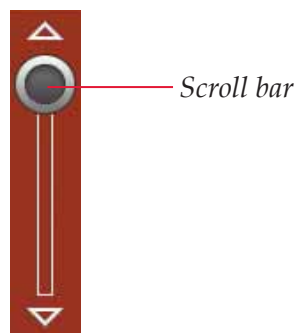

Long touch

Some icons have increased functions, marked with an arrow at the lower right corner. To access these functions, long touch the icon.



OK and Cancel

The OK and cancel icons are used to confirm your settings and selections. They are also used to close full screen windows.

To abort an actual process, touch cancel. To continue, touch OK.



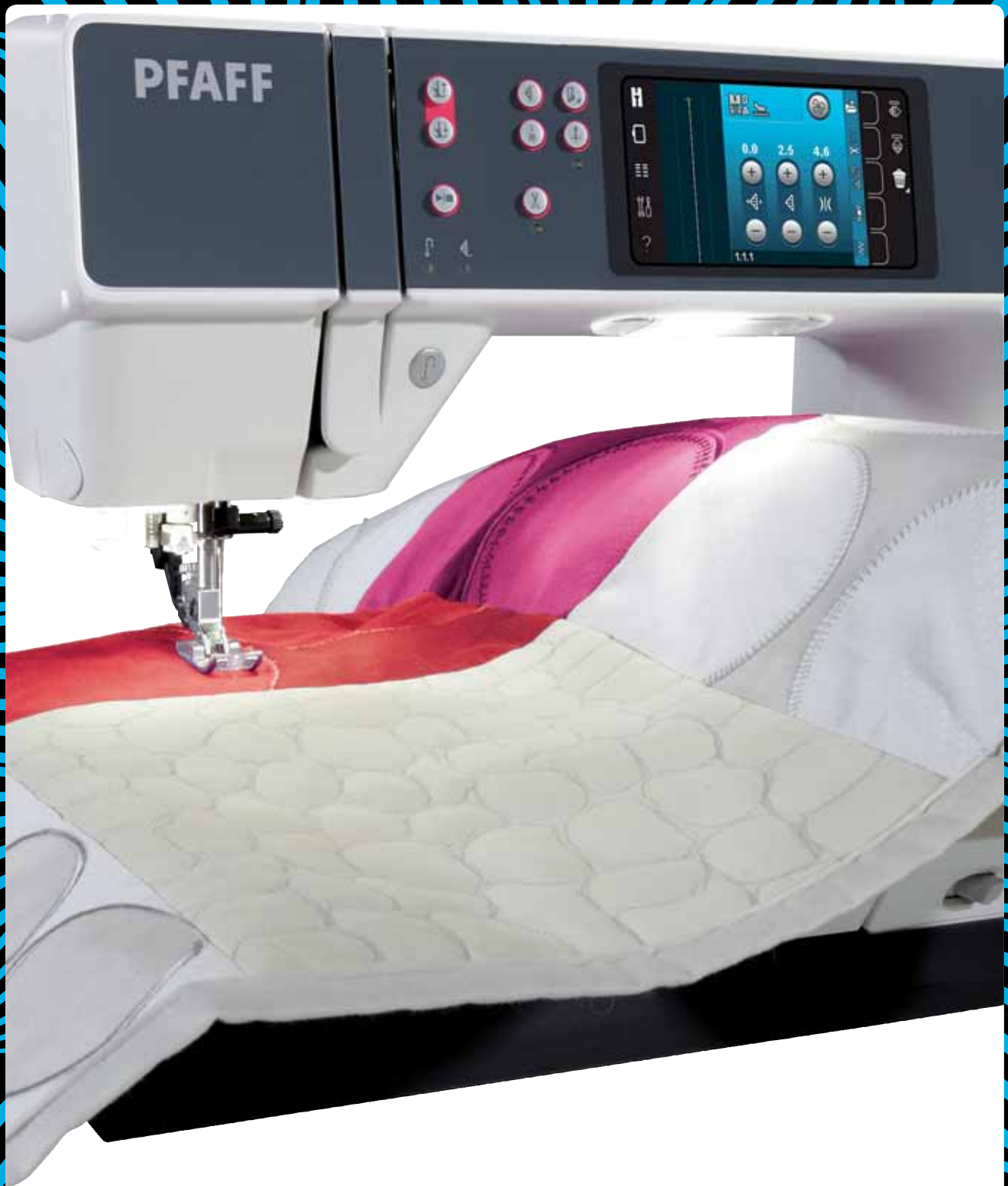

Sewing mode 4

Sewing mode

In sewing mode you can select stitches, adjust and sew them. The selected stitch is shown in actual size in the stitch field. Recommendations and machine settings are shown at the top of the touch screen.

Every mode in the PFAFF® creative™ Color Touch Screen has its own color scheme, to make it easier to navigate and use the machine.

Start view

When your machine is turned on, a start-up screen is shown and then the machine opens sewing mode. If the embroidery unit is attached the machine automatically opens embroidery mode.

Sewing mode - overview

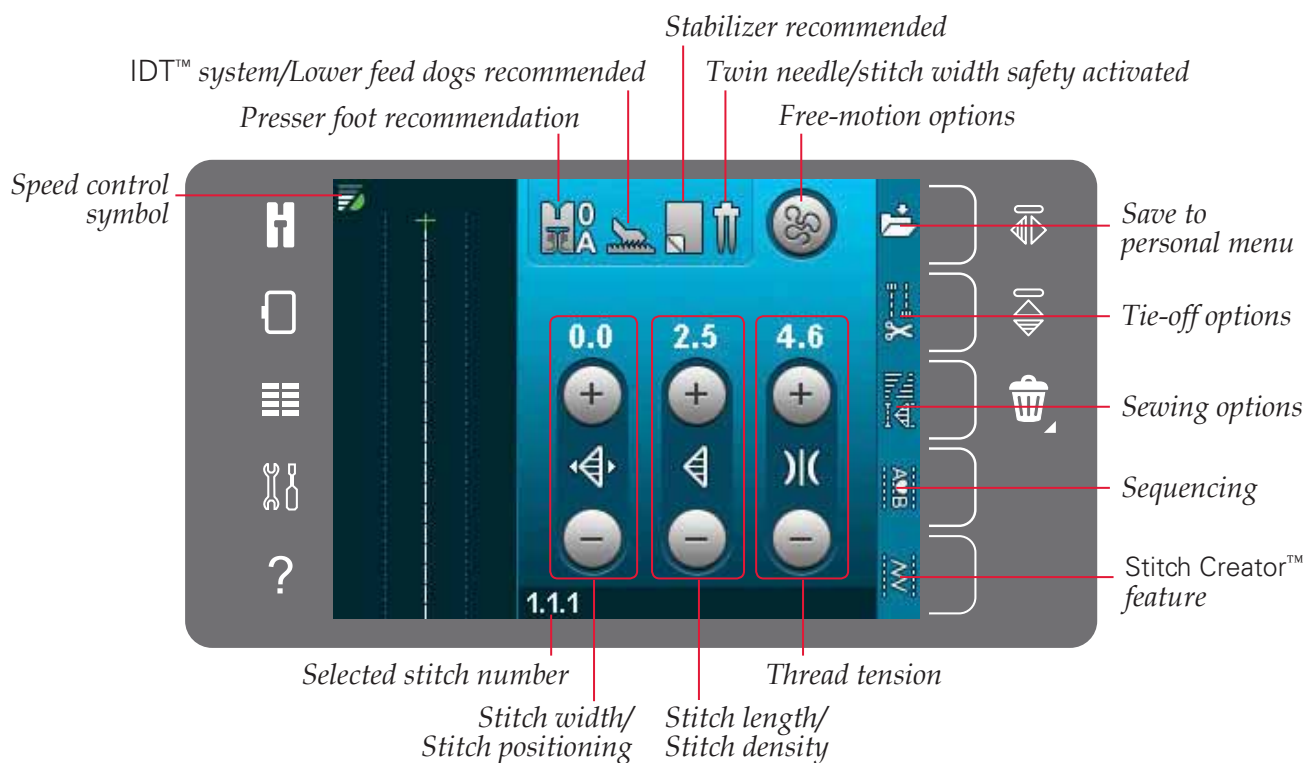

Note: All symbols and options will not be shown at the same time.

Selection menu

To enter selection menu, touch selection menu icon at the left. The selection menu contains a selection bar at the right with icons for stitches, stitch fonts, personal files and USB device. Read more about personal files and USB device in chapter 10.

When a stitch or font is selected, the selection menu will close automatically. A selected stitch font opens in sequence window.

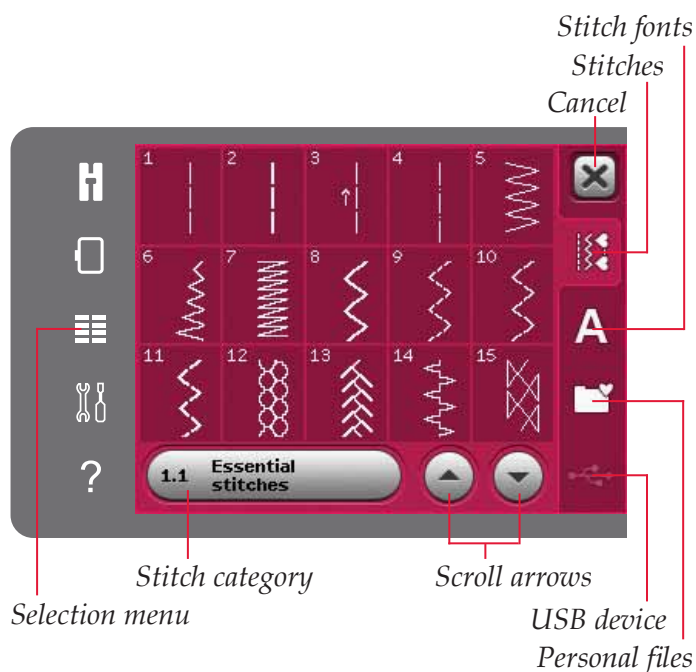

Selecting a stitch

Select a stitch by touching the desired stitch on the screen. Use the scroll arrows to scroll in the list of stitches.

To view all categories, touch stitch category icon. For each category, there are two or more subcategories. For each subcategory a list of stitches is shown.

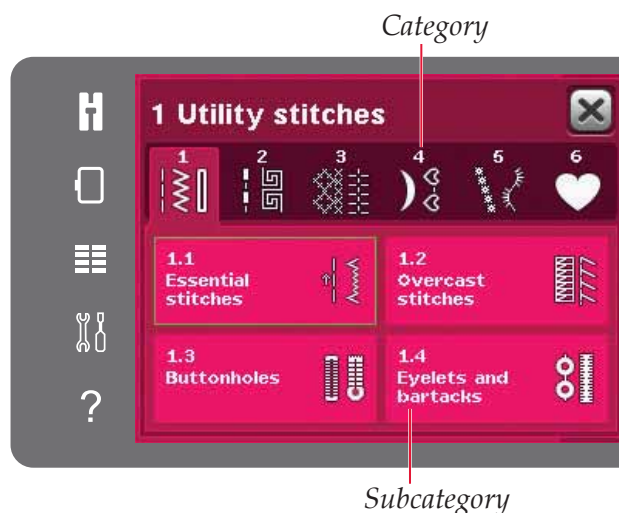

Selecting a font

Text can be created with stitch fonts. To load a stitch font, open the selection menu. Select stitch fonts from the selection bar. Your machine contains four built-in stitch fonts. The number to the right of each font shows the font size. Select a font by touching it. A selected stitch font opens in sequencing. Read more about sequencing in chapter 5.

Note: Stitch fonts are only visible if sewing mode is active.

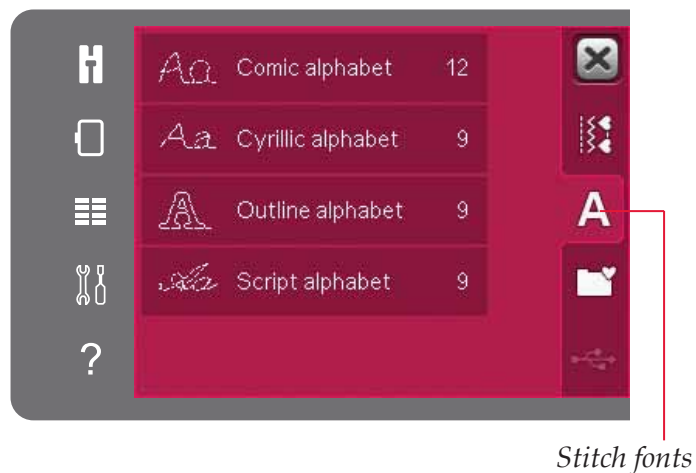

Stitch settings

Your machine will set the best settings for each selected stitch. You can make your own adjustments on the selected stitch. The setting changes will only affect the selected stitch. Your changed settings will be reset to default when selecting another stitch. The changed settings are not automatically saved when turning your machine off. You can save an adjusted stitch in a personal menu to keep the adjustments.

For some stitches you can change more than one setting in each setting control. This will be indicated by a button symbol in the middle of the control. Touch the button symbol to toggle between different stitch settings.

If a stitch can be balanced, a long touch symbol appears in the lower right corner in the middle of the control. Long touch the button symbol to open balance setting.

Note: Some stitches can be balanced but not toggle between two stitch settings (width/positioning) and/or (length/density). If touching once on a button symbol with a long touch the stitch control will not change its appearance. This indicates that the selected stitch cannot toggle between the two stitch settings.

Note: When trying to exceed minimum or maximum settings for the stitch controls, a warning sound will be heard. The default value is shown in white.

Stitch width

Increase or decrease the stitch width using + and -. The number above the control shows stitch width in mm.

Stitch positioning

For certain stitches the stitch positioning icon is shown instead of the stitch width control. Use + to move the needle to the right and - to move the needle to the left. The number above the control shows the needle position in mm in relation to center needle position. For straight stitches the machine has 37 needle positions.

It is possible to change the needle position of all stitches that are less than 9 mm wide. Touch the button symbol in the middle of width/position control to toggle between stitch width and stitch positioning. The stitch position can only be changed to the limit of the maximum stitch width. Changing the stitch position will also limit the stitch width adjustment.

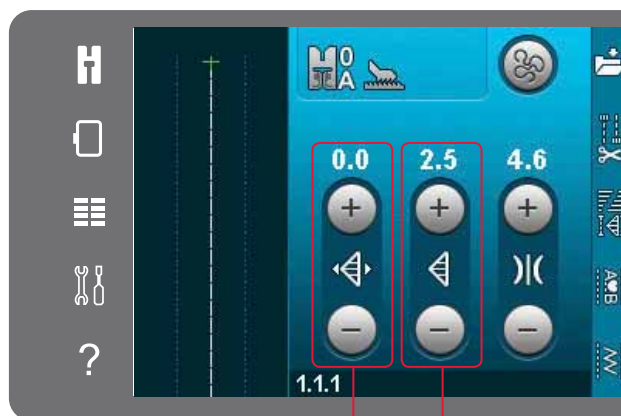

Stitch length/Stitch density
Stitch width/Stitch positioning

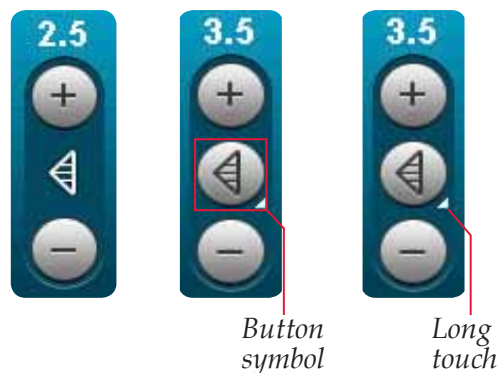

Button symbol
Long touch

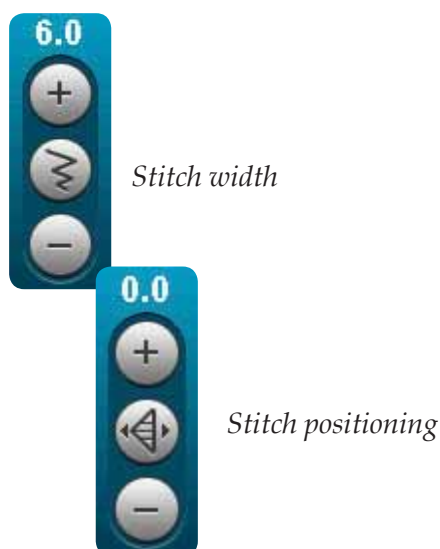

Stitch width

Stitch positioning

Stitch length

Increase or decrease the stitch length using + and -. The number above the control shows stitch length in mm. If lengthening a zigzag stitch or a decorative stitch, the entire stitch will be longer. If lengthening a satin stitch where the density can be adjusted, the entire stitch will be longer but the density will remain the same.

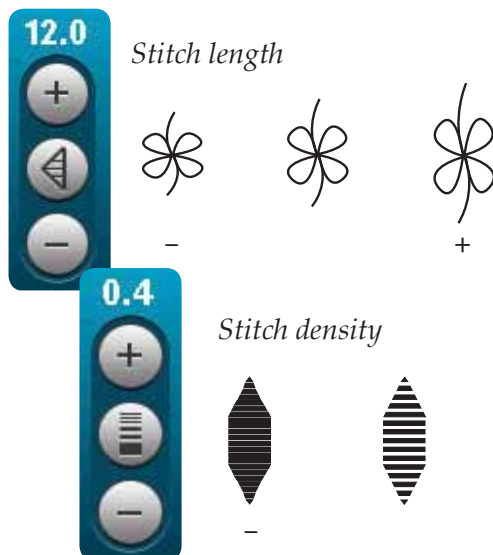

Stitch density

The stitch density control adjusts the density (the closeness of the satin stitches that make up the entire stitch). The density does not affect the actual length of the entire stitch.

Touch + to decrease the density. Touch - to increase the density. The number above the control shows the distance between satin stitches in mm.

Note: This is often used with specialty threads and when a less dense satin stitch is desired.

Balance

When sewing on special fabrics or doing a special technique, the balance may need to be adjusted. If a stitch can be balanced, a long touch symbol will appear in the stitch length/density control.

To ensure a good result, start with sewing a test sample on the fabric you will use. Long touch the stitch length/density control to activate balance. Use the + and - icons to adjust the forward/backward balance of the stitch.

Note: Buttonholes can also be balanced.

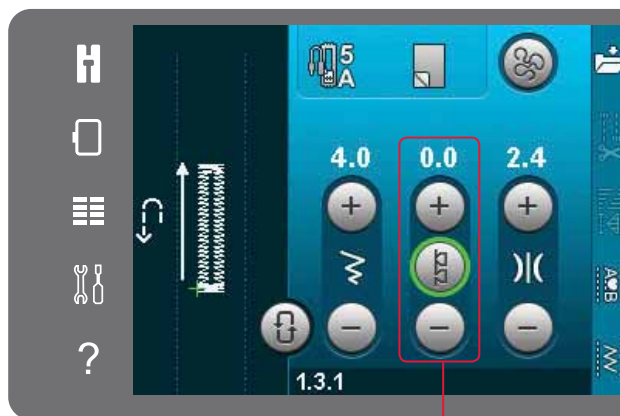

Balance forward/backward

Thread tension

Your machine automatically sets the best thread tension for the selected stitch. The thread tension can be adjusted for specialty thread, techniques or fabric. Touch + to increase and - to decrease the needle thread tension.

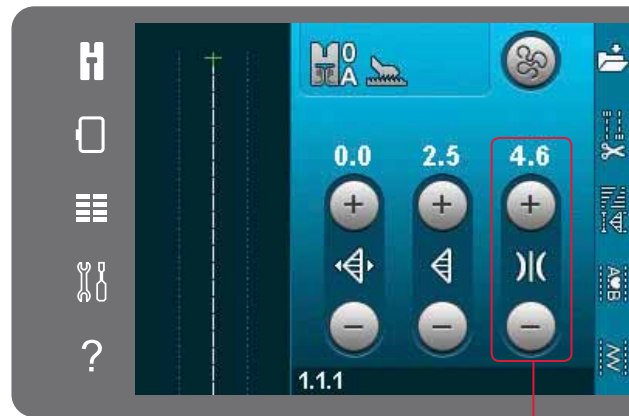

Thread tension

Correct and incorrect thread tension

For the best stitch appearance and durability make sure the needle thread tension is correctly adjusted, i.e. for general sewing, the threads evenly meet between the two fabric layers (A).

If the bobbin thread is visible on the top side of the fabric, the needle thread tension is too tight. Reduce the needle thread tension (B).

If the needle thread is visible on the back side of the fabric, the needle thread tension is too loose (C). Increase the needle thread tension.

For buttonholes and decorative stitches the needle thread should be visible on the underside of the fabric (C). Reduce the needle thread tension to bring the needle thread back side of the fabric.

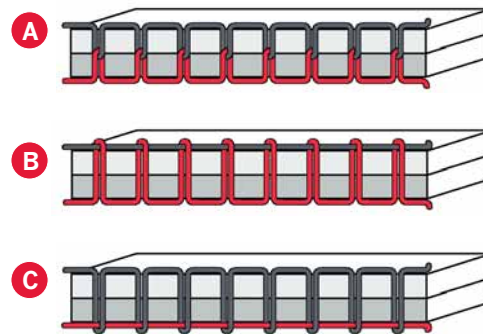

Mirroring

To mirror a stitch or sequence horizontally, touch the mirror side to side icon. To mirror vertically, touch the mirror end to end icon.

Note: Buttonholes cannot be mirrored.

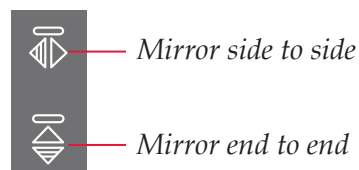

Save to personal menu

To save a stitch, touch the save to personal menu icon in sewing mode. You will find saved stitches in category 6, personal menu. Each subcategory in the personal menu has 10 positions to save your own stitches or sequences. Choose the subcategory you want to save your stitch in. All your previously saved stitches will be shown in the personal menu.

You can scroll through the personal menus to find a free position, using the scroll arrows. Any box without a stitch is a free position and can be used to save your new stitch. Simply touch the position and your stitch is saved.

Any box with a stitch is an occupied position. You can overwrite a previously stored stitch. Simply touch the stitch to overwrite. A pop-up will appear to confirm that you want to overwrite the previously stored stitch. Cancel the saving process by touching the cancel icon. The saving window will close and you will return to the previous screen.

Delete a stitch

If you want to delete one stitch, first touch delete (A). A highlighted green delete symbol (B) will appear at the lower right to indicate that delete is active. Then touch the stitch you want to delete. The position will be emptied. To abort the deletion before selecting a stitch, touch delete again (A). Long touch delete to empty the whole subcategory that is selected.



Save to personal menu

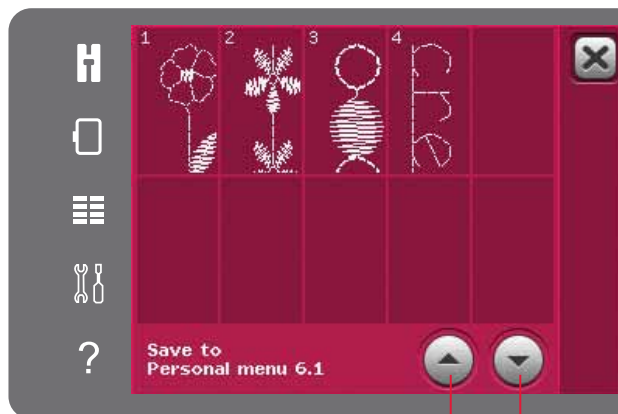

Scroll arrows

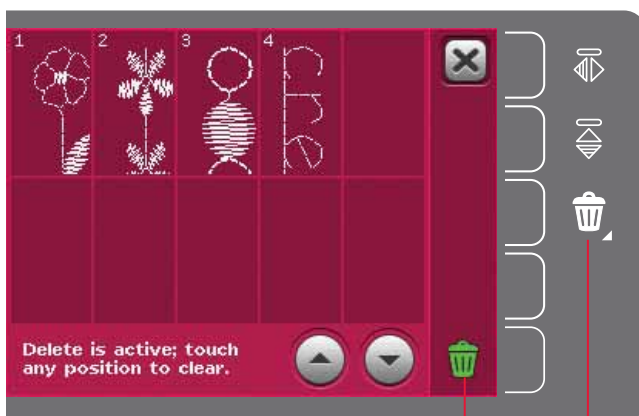

Delete (A)
Delete symbol (B)

Free-motion options

All stitches on your machine can be sewn in free-motion to create fantastic effects.

Touch the free-motion options icon to open a window where you can select between three different free-motion options. The selected free-motion option is shown at the top of the screen by a free-motion options symbol. Use quick help on the symbol for information about the current setting.

For all free-motion sewing the fabric must be moved manually and the feed dogs need to be lowered. See page 2:9 for information on how to lower the feed dogs. On the top of the screen, a lower feed dogs recommendation will be shown.

Note: Make sure that the IDT™ system is disengaged.

Read more about free-motion sewing on page 4:20

Dynamic spring foot 6D free-motion

Activate to set the machine in Dynamic spring foot free-motion mode for the Dynamic spring foot 6D (optional accessory, part number 820991-096). The Dynamic spring foot measures the fabric thickness and will raise and lower with each stitch to hold the fabric on the needle plate while the stitch is being formed.

Note: The Dynamic spring foot 6D is recommended for use with straight stitch. Activate Stitch width safety in Machine settings.

Spring foot free-motion

Activate to set the machine in Spring foot free-motion mode for optional spring feet. A spring foot will raise and lower with each stitch to hold the fabric on the needle plate while the stitch is being formed.

Note: Optional spring feet can be purchased at your local authorized PFAFF® dealer.

Free-motion options symbol

Lower feed dogs recommendation

Free-motion options

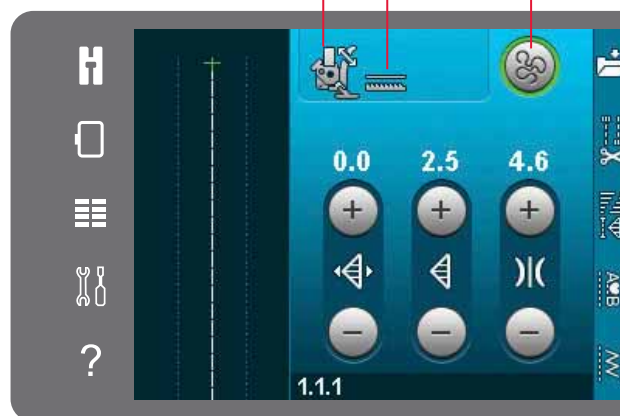

Dynamic spring foot 6D free-motion



Spring foot free-motion



Sensormatic free-motion

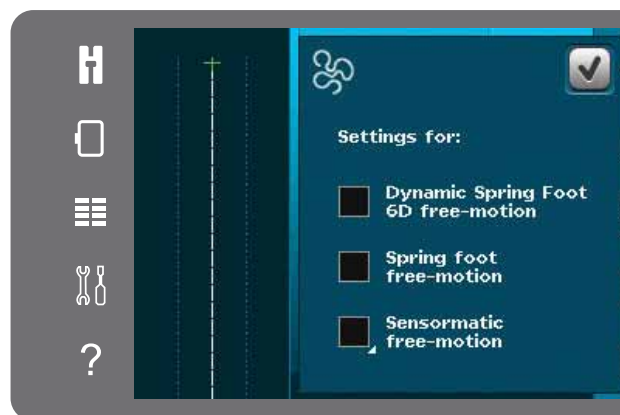

Sensormatic free-motion

Activate to set the machine in Sensormatic free-motion mode for, e.g. Embroidery/Sensormatic free-motion foot 6A.

When sewing free-motion at low speed the presser foot will raise and lower with each stitch to hold the fabric on the needle plate while the stitch is being formed. At higher speed, the presser foot floats over the fabric while sewing.

Skipped stitches can occur if your fabric moves up and down with the needle as you are stitching. Lowering the presser foot height will reduce the space between the presser foot and the fabric and eliminate the skipped stitches.

To adjust the presser foot height in Sensormatic free-motion mode, long touch the check box and make adjustments in the pop-up.

Note: Be careful not to reduce the presser foot height too much. The fabric must still move freely under the presser foot.

Do not use a spring foot if Sensormatic free-motion is activated, since the needle might damage the presser foot.

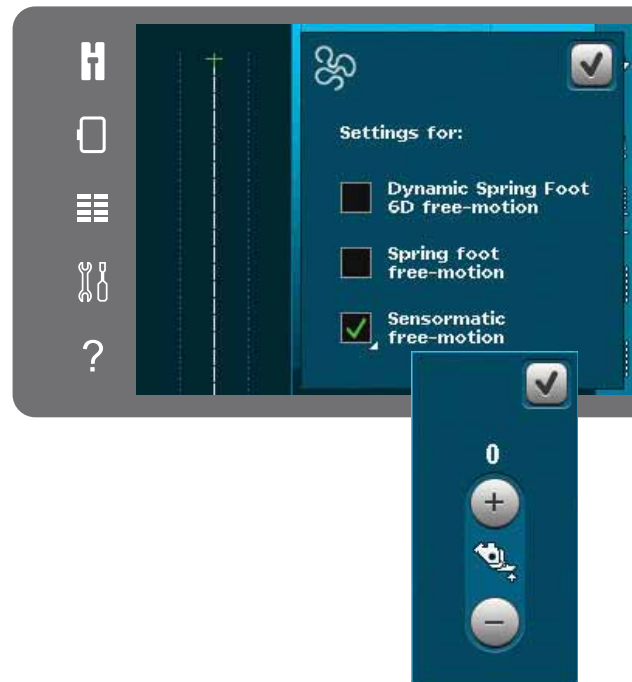

Presser foot height



Tie-off options

When touching the tie-off options icon, a foldout opens to let you select three different functions; tie-off beginning, tie-off end and thread snips.

When you have activated your settings, you can hide the three icons by touching the tie-off icon on the option bar again. The tie-off options icon will show your settings by changing the color of the chosen function. The settings will remain active until you switch them off.

Note: For immediate tie-off, use the Immediate tie-off button, placed on the front of the machine among the buttons.

Sewing with tie-off options selected

1. The tie-off beginning will be performed as soon as you start to sew.
2. Press the reverse button to perform tie-off end. The action indicator will be lit. The machine will finish the stitch and do a tie-off.

When a thread snip is programmed, the machine will automatically cut the threads after performing the tie-off end. The needle and presser foot will raise.

Note: To activate reverse sewing, stop sewing and press the reverse button. The reverse indicator will be lit. No tie-off will be performed.

Press the reverse button when sewing in reverse to activate tie-off end. Both the reverse indicator and the action indicator will be lit.

To go back to sewing forward, stop sewing in reverse and press the reverse button. No indicators will be lit and no tie-off will be performed.



Tie-off options



Tie-off beginning

Tie-off end

Thread snips

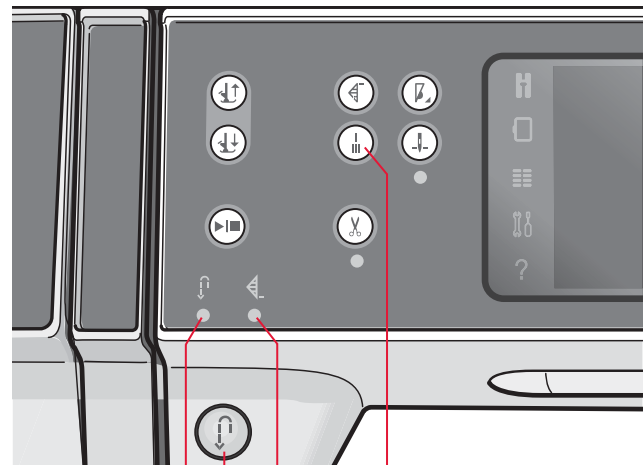

Immediate tie-off

Action indicator

Reverse button

Reverse indicator

Sewing programs

These options let you activate tapering, single stitch and patchwork programs. You can sew without closing this pop-up.

Note: Not all programs can be used at the same time.

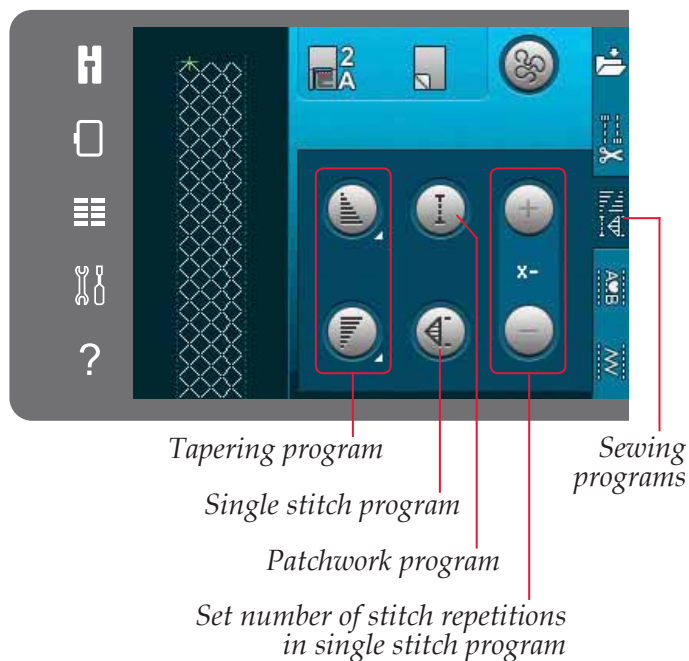

Tapering program

Tapering increases or decreases the width of the stitch during sewing to create symmetrical or asymmetrical tapers.

Activate tapering by selecting either of the tapering icons. The default angle is 45 degrees. Long touch a tapering icon to view the angle choices for that taper. Select one angle for the beginning taper and the same angle or a different one for the end taper.

If tapering is deactivated and then activated again, the angle will be set to the previously selected angle.

When tapering is activated at both the beginning and at the end and you start to sew, the stitch width will start at 0mm. It becomes wider until the selected stitch width is reached. Sew your desired length and press the reverse button. The width is reduced until the width is 0mm and the action indicator on the machine will be lit until the taper is finished.



Pop-up for tapering program

Single stitch program

Activate the single stitch program by touching the icon. The single stitch program lets you decide how many repetitions of the stitch you want to sew.

Set the number of repetitions using the icons on the right. The number of repetitions chosen is shown between the + and - icons. The machine will stop automatically when the repetitions are sewn.

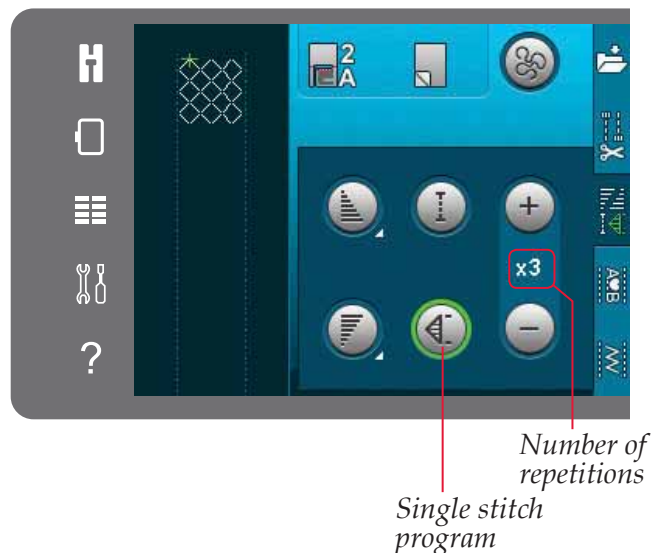

Patchwork program

The patchwork program makes it possible for you to program an exact seam length that can be sewn repeatedly. This is very useful when quilting.

To program a seam length, activate the patchwork program. Sew your desired seam length and press the reverse button. The action indicator on the machine will be lit until the last repetition of the stitch is finished. This will set the length of the seam.

After you have programmed the patchwork sequence, the patchwork program icon is inactive. The single stitch program is now activated instead.

Combining Tapering and Patchwork or Single stitch programs

Combining Tapering and Patchwork or Single stitch programs makes it possible to repeat a tapered seam with the same length.

Activate tapering by selecting any of the tapering icons then activate Patchwork by touching the icon. Follow the instructions for tapering on the previous page. When the reverse button is pressed the action indicator will be lit until the taper and last repetition of the stitch is finished.

The stitch is now programmed and the single stitch program is activated. When you start to sew again the stitch will automatically be repeated with the same length.

Between the + and - icons the number of repetitions in the program is shown. Use the + and - icons to adjust the length of the seam.

Note: The tapering is included in the repetitions shown on the screen.

Sequencing

Touch this icon to open sequencing. In sequencing you can create and adjust a sequence of stitches and letters. Read about sequencing in chapter 5.

Stitch Creator™ feature

Touch this icon to open Stitch Creator™ feature. Stitch Creator™ feature allows you to create your own 9mm stitches or edit built-in stitches. Every single stitch point can be edited. Read about Stitch Creator™ feature in chapter 6.

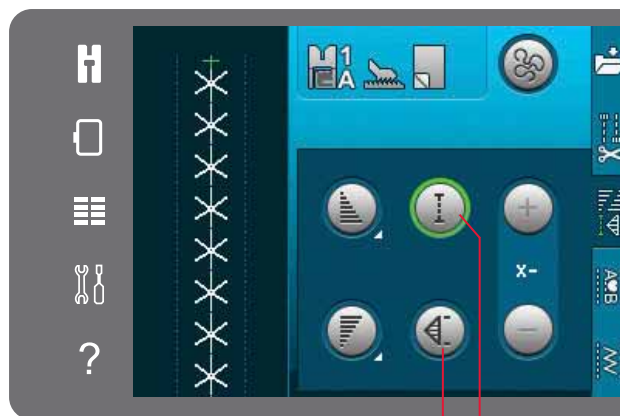

Singel stitch program

Patchwork program

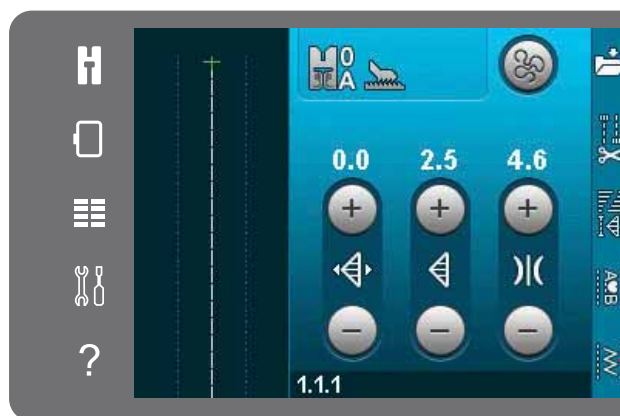

Stitch Creator™ feature

Sequencing

Sewing techniques

These techniques may require some special presser feet and accessories.

Sewing in zippers

There are different ways to sew in zippers. Follow the directions included with your pattern for best results.

For some types of zippers it is important to sew close to the teeth of the zipper. The zipper foot 4 can be snapped to the presser foot bar on the left or right, depending on how you will insert your zipper. Then set the stitch position so that it enters close to the edge of the zipper teeth by using one of the 37 needle positions available for the straight stitch.

Note: If the presser foot is attached on the right side of the presser foot bar, the needle must only be moved to the left. If the foot is attached on the left side of the presser foot bar, the needle must only be moved to the right.

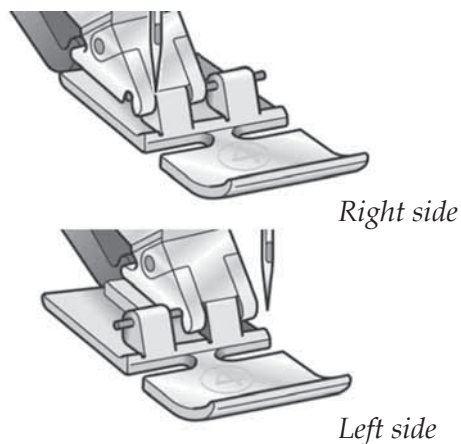

Sewing hems in heavy fabric

When sewing over seams in extra heavy fabric or a blue jeans hem, the presser foot can tip as the machine climbs over the seam.

Use the multipurpose tool to balance the height of the presser foot as you sew. One side of the tool is thicker than the other. Use the side that suits the thickness of the seam best.

Engage the IDT™ system, see page 2:8. At the thickest point on the fabric, slow down the sewing speed.

Tip! Increasing the stitch length may improve the sewing result when sewing hems in heavy fabric.

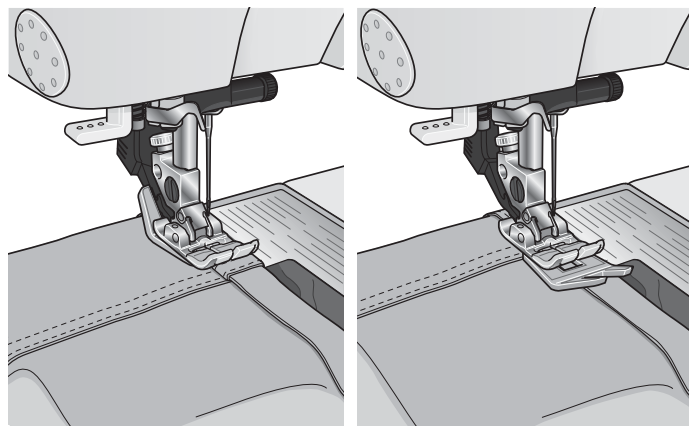

Three-step zigzag stitch

Stitch number 1.1.9 can be used to overcast raw edges. Make sure the needle pierces the fabric on the left side and overcasts the edge on the right side.

Stitch number 1.1.9 can also be used as an elastic stitch to add elastic to pajamas, skirts and sportswear.

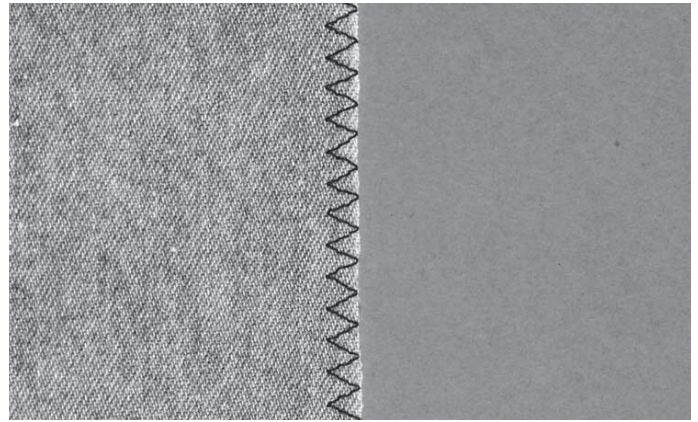

Blindhem stitch

The blindhem stitch number 1.1.16 is used to make invisible hems on skirts, trousers and home decorating. Use foot number 3 with IDT™ system.

- Finish the edge of the hem.
- Fold and press the hem allowance to the wrong side.
- Fold the hem back on itself so approximately 3/8" (1 cm) of the finished edge extends beyond the fold. The wrong side of your project should now be facing up.
- Place the fabric under the presser foot so that the fold runs along edge guide A.
- When the needle swings into the fold it should catch a small amount of fabric. If the stitches are visible on the right side, adjust edge guide A by turning adjusting screw B until the stitch that catches the hem just barely shows.

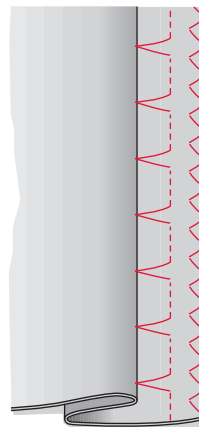
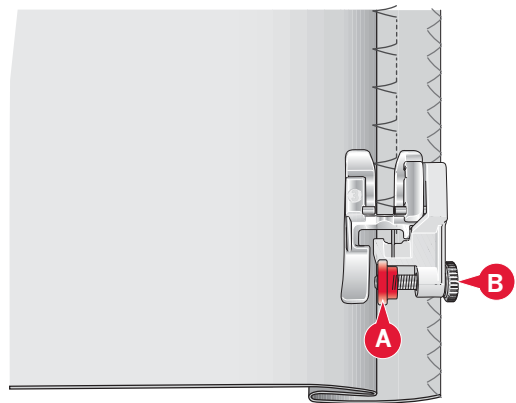

Blindhem stitch number 1.1.16

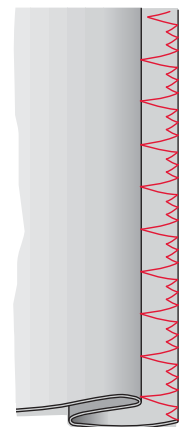

Elastic blindhem stitch number 1.1.17

Elastic blindhem stitch

The elastic blind stitch number 1.1.17 is especially suitable for stretchy fabrics, because the zigzag in the stitch lets the stitch stretch. The hem is finished and sewn at the same time. There is no need to finish the raw edge first on most knits.

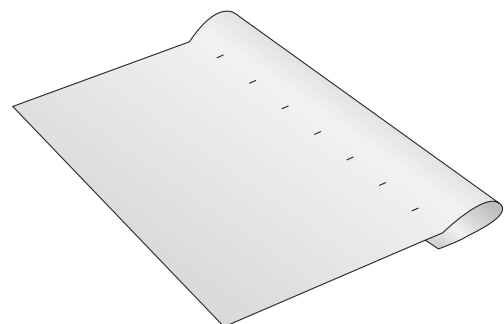

Buttonholes

Buttonholes are found in category 1, subcategory 1.3 in the selection menu.

Note: Buttonholes up to 50mm can be sewn using the Sensormatic buttonhole foot 5A. Both sides of the Sensormatic buttonhole are sewn in the same direction for a more even result.

Buttonholes over 50mm are sewn manually in four steps with presser foot 5M.

The direction of the stitches being sewn will be indicated on the screen by an arrow next to the buttonhole.

To sew a buttonhole, first attach the correct foot, then select your buttonhole. To ensure a good result, start with sewing a test sample on the fabric and stabilizer you will use.

Note: Make sure that the IDT™ system is disengaged.

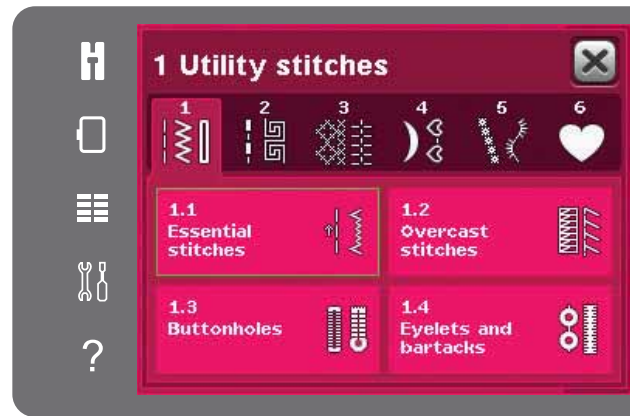

Attaching the Sensormatic buttonhole foot

1. Snap on the Sensormatic buttonhole foot.
2. Plug the cord into the socket found to the left above the needle area, behind the needle threader (A).

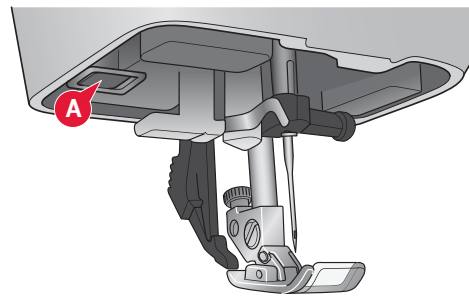

Sensormatic buttonhole

When you sew a buttonhole with the Sensormatic buttonhole foot, adjust the slit length so that it is slightly larger than the size of the button. You can measure your button using the button ruler on the lid.

Set the slit length and make sure that the red arrow lines up with the marking on the foot (B). Start sewing by pressing the foot control or start/stop button. The buttonhole will be completed automatically and the threads are cut. You can repeat the buttonhole as many times as you wish.

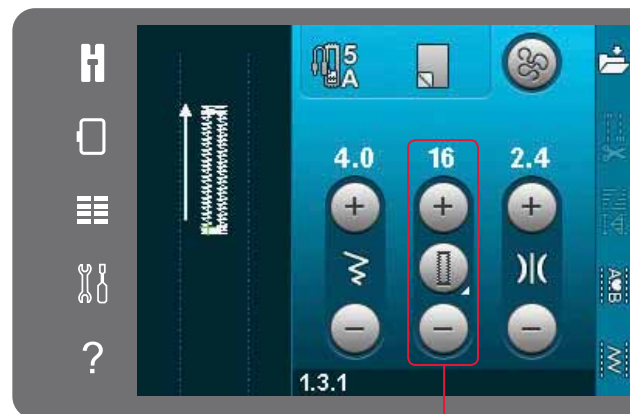

Slit length

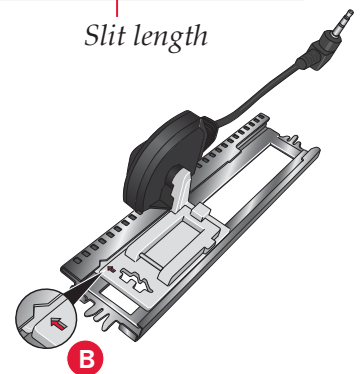

Manual buttonhole

To sew a manual buttonhole, use presser foot 5M. Sew the first column as long as you want the buttonhole. Touch the reverse button. The machine sews the bartack and the second column. When the columns are aligned, press the reverse button to sew the second bartack.

Repeat a manual buttonhole

When you have adjusted your buttonhole, use the repeat buttonhole function to sew identical copies. As long as that icon is selected, the machine will repeat the buttonhole over and over again. Repeat buttonhole is only visible when sewing a buttonhole manually.

To cancel the function, just deselect the icon. The repeat function will also be cancelled if any adjustments are made.

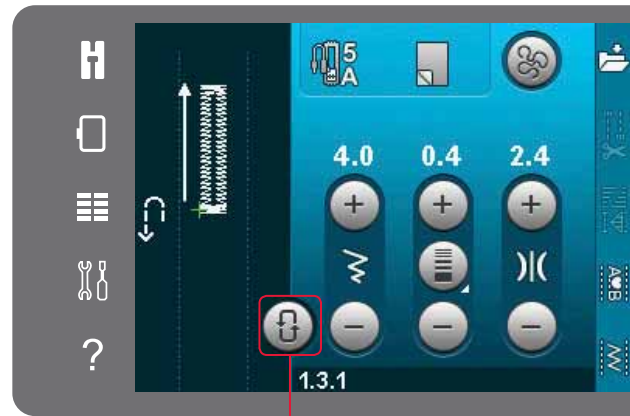

Repeat buttonhole

Corded buttonhole

Corded buttonholes that are sewn with gimp threads are more stable, durable and have a professional appearance. Use pearl cotton or a regular gimp thread.

1. Place the center of a length of gimp thread over the metal bar extending from the center back of the Manual buttonhole foot 5M. Pass the thread ends under the foot to the front of the foot.
2. Snap on the Manual buttonhole foot 5M.
3. After completing the buttonhole, pull the ends of the gimp thread until the loop of thread is hidden below the buttonhole bartack.
4. Thread the gimp threads into a needle and pull them to the wrong side of the garment. Tie the gimp threads and cut off the excess thread.

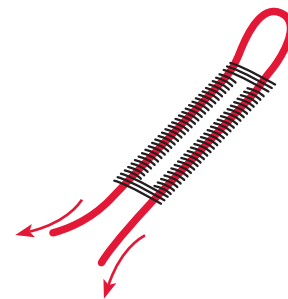
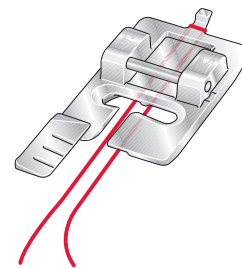

Sew on a button

To sew on a button, remove the presser foot and select the sew on button stitch. Lower the feed dogs, see page 2:9.

Place the button under the presser foot holder. Use the mirror side to side icon to make sure the holes in the button are aligned with the swing of the needle and the width is appropriate for the actual button. If needed change the stitch width to align with the holes in the button with the stitch width control.

If needed, increase or decrease the number of stitches that will fasten the button on the fabric, using the button stitch repetition icons. Start to sew. The machine will sew the program for you.

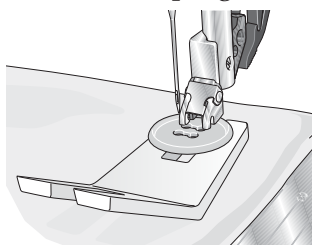

Note: Use the multi-purpose tool to create a thread shank for your button. You can also use a sew on button foot, available as an optional accessory at your local authorized PFAFF® dealer.

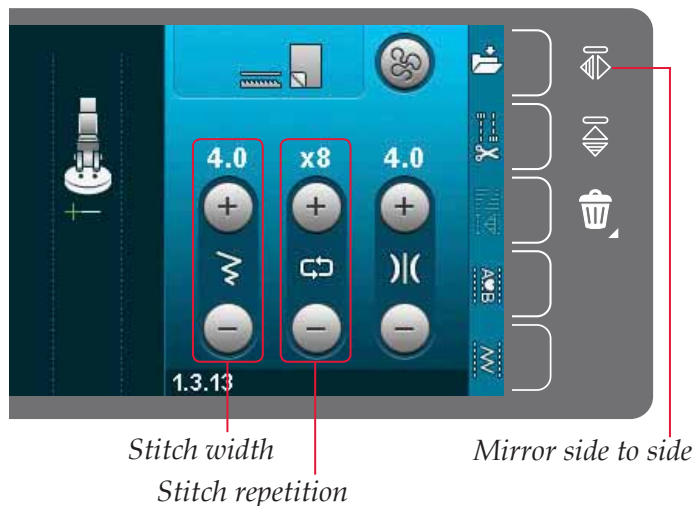

Darning

Darning a small hole or a tear before it becomes larger can save a garment. Choose a lightweight thread in a color as close to your garment as possible.

1. Place fabric or stabilizer in position under the hole or tear in your garment.
2. Select a darning stitch.
3. Start sewing beside, above the hole and then over it.
4. Once you have sewn across the hole, press the reverse button to set the length of the stitch. Your sewing machine will automatically complete the stitch.
5. By default, the machine will be set to repeat the same size darning square; just continue sewing.

The repeat icon will be highlighted, indicating that repeat is activated. Touch the repeat icon to deactivate repeat.

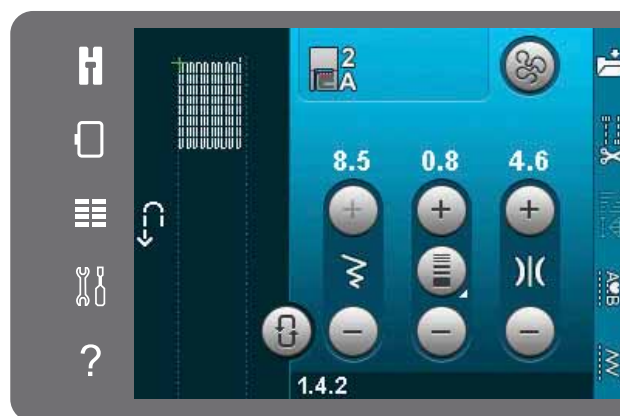

Quilting

A quilt usually consists of three layers, two layers of fabric with a layer of batting sandwiched between.

To sew three layers together, you have a wide variety of stitches and techniques to choose from.

Straight stitch needle plate (optional)

Attach the straight stitch needle plate (optional accessory, part number 4129643-04) when piecing your quilt. The smaller hole in the straight stitch needle plate supports the fabric closer to the needle and helps prevent the fabric from being pulled down into the bobbin area, especially at the beginning and/or end of a seam.

Note: Activate stitch width safety in the Settings menu when the using straight stitch needle plate.

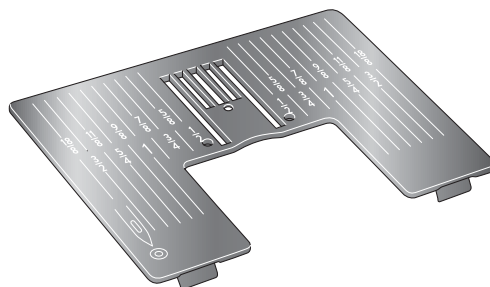

Patchwork program

The patchwork program makes it possible for you to program an exact seam length that can be sewn repeatedly. This is very useful when quilting, especially when piecing many quilt blocks of the same size.

See page 4:12 on how to use the patchwork program.

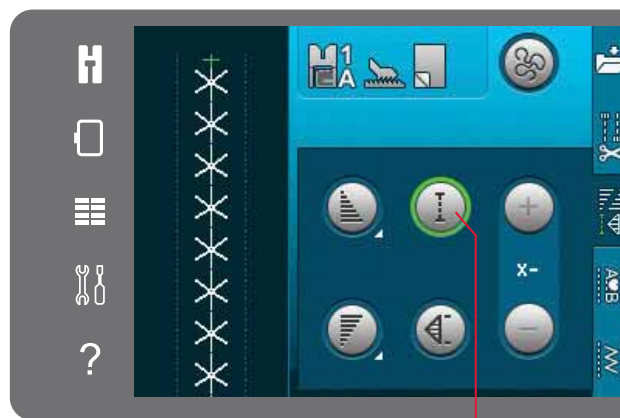

Patchwork program

Piecing the quilt top

Cut out the pieces of fabric for your quilt top with a seam allowance of $\frac{1}{4}$ " (6mm). Snap on the $\frac{1}{4}$ " quilting foot with IDT™ system; position the fabric under the foot so that the cut edge is aligned with the outer edge of the toe of the foot.

Press the seam flat to lock the stitches, then open the pieces and press the seam allowance to one side. When possible, press seam allowances towards the darker fabric.

Assemble the pieces according to the pattern instructions. Layer the pieced quilt top with batting and backing. Pin baste the layers together in preparation for quilting.

Handlook quilting

1. Baste the completed quilt top to the batting and backing.
2. Thread the needle with an invisible (monofilament) thread. Use contrasting or matching rayon or cotton thread in the bobbin.
3. Snap on the recommended foot shown in the sewing recommendations view.
4. Engage the IDT™ system.
5. Select one of the handlook quilt stitches 5.2.1-5.2.11. These stitches are pre-set with a higher thread tension value to intentionally pull up bobbin thread and produce the desired "hand look" effect.

Note: Use needle size 90 and lightweight, soft cotton bobbin thread when sewing handlook quilt stitches. You might need to adjust the thread tension depending on which fabric, thread and batting that is used. Make a few tests on a scrap piece of the fabric you are going to sew and check the tension.

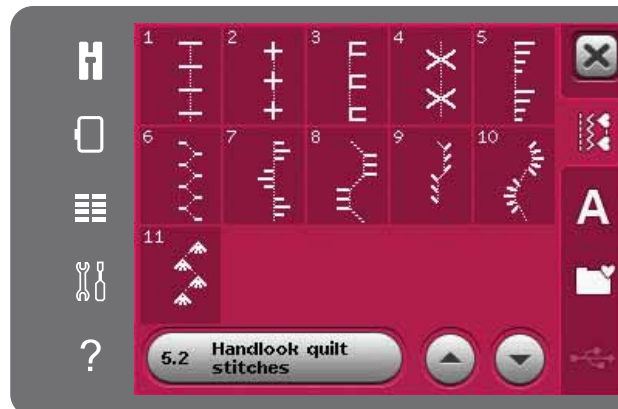

Stitch-in-the-Ditch

Stitch-in-the-ditch is another option for joining the layers of your quilt. Pin baste the layers as described above. Snap on the Fancy stitch foot 1A with IDT™ system and engage IDT™ system. Stitch in the seams of the quilt, using the red line on the presser foot as a guide.

Note: You can also use the optional presser foot, Stitch-in-Ditch w/IDT™ system (part number 820 925-096).

Crazy quilt stitching

Embellish your quilt with decorative stitches from stitch category 2.4. The stitches can be sewn in a coordinating or contrasting color, depending on the desired effect. Decorative threads like rayon embroidery or 30 wt cotton thread are sometimes used.

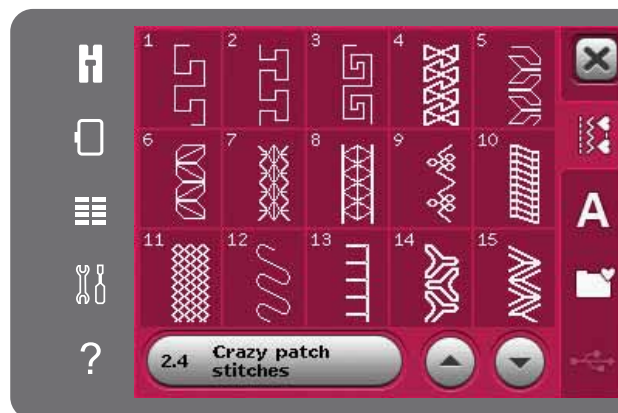

Free-motion stippling

Free-motion stippling adds texture and interest to your quilt, while keeping the layers together.

Free-motion stippling is done with the feed dogs lowered. You move the fabric manually to determine the stitch length.

1. Set your sewing machine for free-motion sewing with a straight stitch. Attach the straight stitch needle plate. Activate stitch width safety in the Settings menu, see page 3:4. Lower the feed dogs, see page 2:9. Touch the free-motion options icon and select one of the three options.

Note: Read about the different options on page 4:8.

2. Disengage the IDT™ system and attach the correct free-motion foot depending on which technique you have selected. A symbol of the foot for the selected setting is displayed at the top of the screen.
3. Begin by pin basting your quilt through all layers with safety pins, starting from the center of your quilt and working out. Place a pin every 6-8 inches (15-20cm).

Tip! Practice stippling on scraps of the fabric and batting from your quilt. It is important to move the fabric at the same rate as the sewing speed to prevent stitches that are too long or too short. Maintaining a consistent speed while free-motion sewing will also help keep stitches even. To get an even speed, lower the sewing speed and press the foot control.

4. Begin near the center of your quilt. Take one stitch and pull the bobbin thread to the top of the quilt. Take a few stitches right next to one another to lock the threads. Activate Needle down.
5. Plan a path for your stitching, then begin stitching your desired stipple pattern, moving the quilt as you go. Continue stippling until all areas of the quilt top are filled.

Special sewing techniques

The 5th stitch category includes special sewing technique stitches such as candlewicking, join and fold, three hole yarn, beading stitches and edge stitches. These techniques may require some special presser feet and accessories. This is indicated by the optional presser foot icon.

Note: Touch Quick help and then touch the selected stitch in the selection menu to find out which special presser foot is required for that stitch.

Free-motion options symbol

Free-motion options

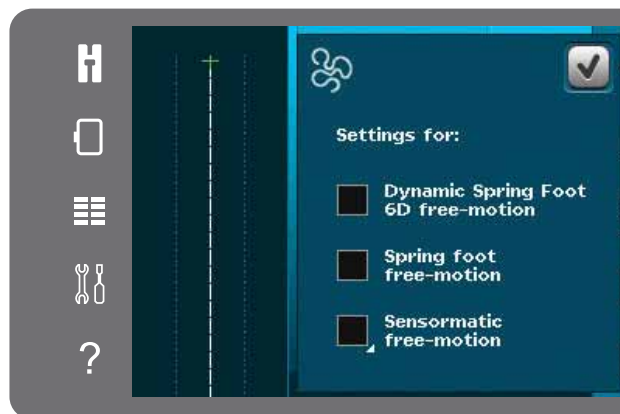

Dynamic spring foot 6D free-motion



Spring foot free-motion



Sensormatic free-motion

Optional presser foot icon

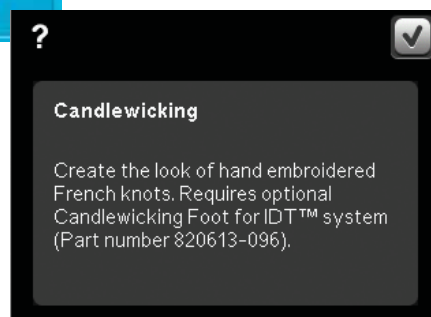

Common sewing pop-ups

Bobbin thread low

When the bobbin thread is running low, a pop-up message appears giving you an indication that the bobbin needs to be changed soon. This gives you an opportunity to plan where to stop sewing and change the bobbin. If you want to continue sewing, touch the foot control without closing the pop-up. When the bobbin is replaced with a full one, touch OK in the pop-up.

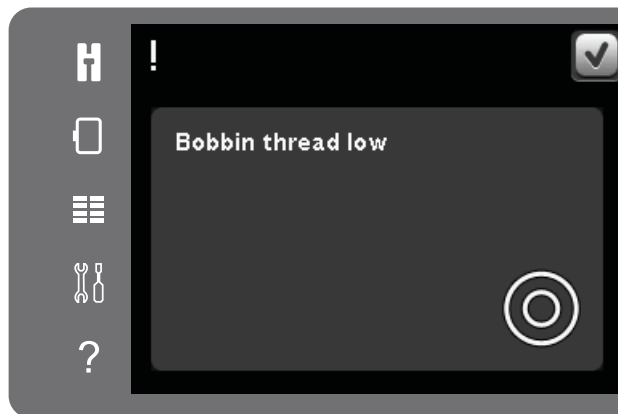

Check needle thread

The machine stops automatically if the needle thread runs out or breaks. Re-thread the needle thread, close the pop-up and start sewing again.



Remove Sensormatic buttonhole foot

The Sensormatic buttonhole foot needs to be removed before doing any of the following:

- Sewing a stitch that is not a buttonhole.
- Sewing a buttonhole that can not be sewn with the Sensormatic buttonhole foot.
- Sewing an adjusted buttonhole saved without the Sensormatic buttonhole foot in your Personal menu.

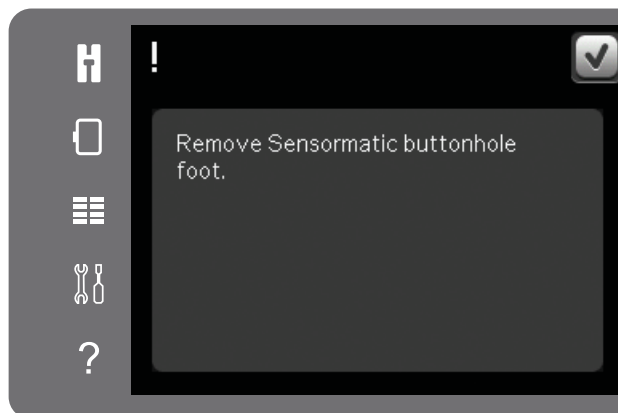

Machine needs to rest

If the machine stops and this pop-up appears on the screen, the machine needs to rest. When the OK icon is enabled you can resume sewing. The sewing results will not be affected.

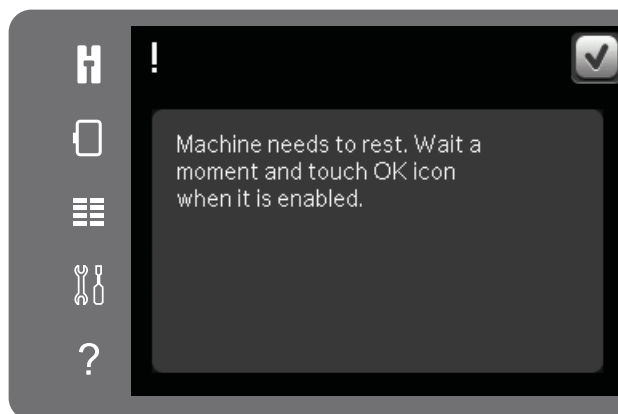





Sequencing 5

Sequencing

You can combine stitches and/or letters and numbers to create sequences. Combine various decorative stitches and stitch fonts from the machine or from an external device. Stitches made in Stitch Creator™ can also be inserted in a sequence.

Note: If you mix tapering stitches with other stitches in Sequencing, the sequenced stitch cannot be tapered. However, if you only program tapering stitches, the entire sequenced stitch can be tapered.

Sequencing - overview

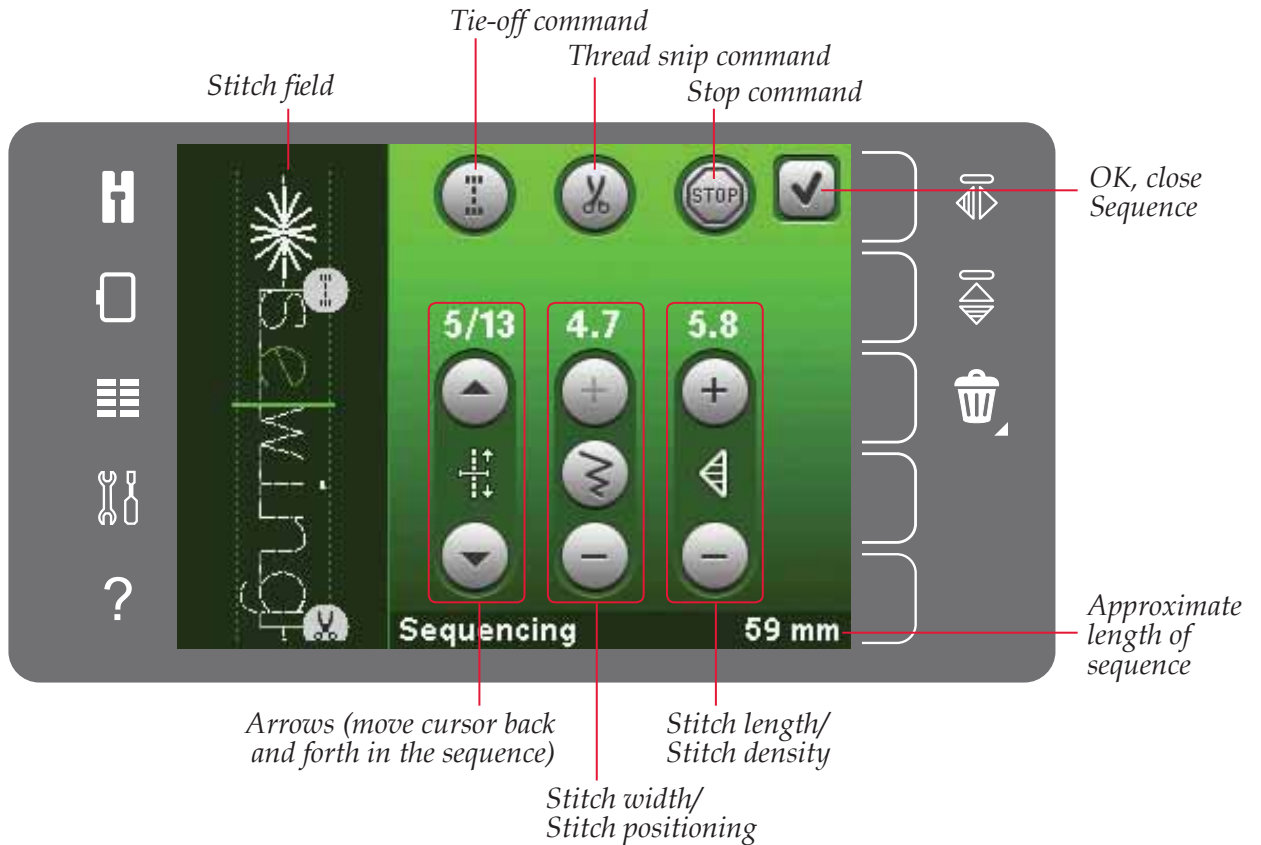

Note: All symbols and options will not be shown at the same time.

Open and exit sequencing

Sequencing can only be used in sewing mode. To open, touch the sequencing icon on the option bar. To close sequencing and sew your created sequence, touch OK in the top right corner in sequencing window.

Note: You can also close sequencing by pressing the foot control or by pressing the start/stop button.

Not all stitches are available to use in a sequence. If you try to select an unavailable stitch, a pop-up will notify you.

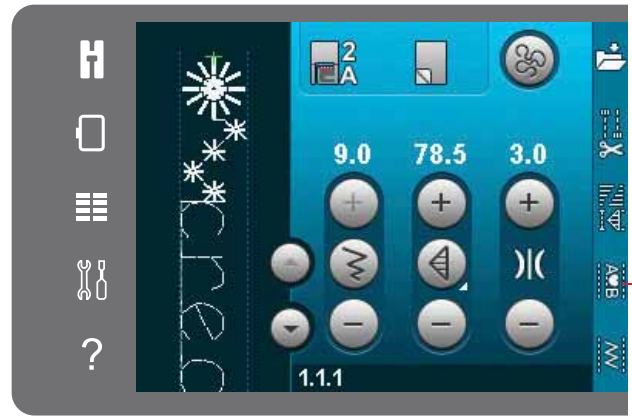

Sequencing
Stitch fonts
Stitches

Create a sequence

To start creating a sequence, find the desired stitch and/or font by opening the selection menu.

Create sequence from stitches

Open selection menu. Use the scroll arrows to scroll through the list of stitches. Touch a stitch in the selection area to add it to the sequence. To get an overview of all stitch categories, touch the stitch category icon.

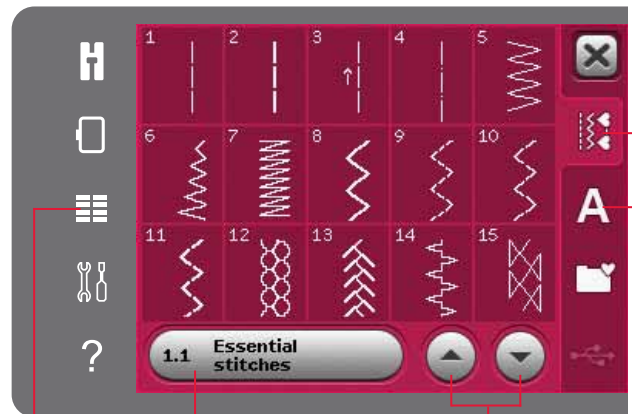

Stitch category
Scroll arrows
Selection menu

Create sequence from letters

Open the selection menu. Touch stitch fonts to open a window with available stitch fonts. Touch to load the desired stitch font into sequencing.

Touch font style icon to toggle between upper or lower case letters, numbers or special symbols. Move the cursor through the sequence using the forward/backward arrows. To delete a letter or stitch, touch delete. Long touch to delete the whole sequence.

The active position is marked by a cursor and the selected stitch or letter will be marked in green. Inserted stitches will be placed at the cursor position. Only the selected stitch can be adjusted.



Font style
Delete
Forward/backward arrow

Insert a stitch or letter

Move the cursor where you want to add a stitch or letter. Select the desired stitch you want to insert. It will be placed at the cursor position.

Adjust text and stitches

You can mirror, adjust length and width or change the density or position of the selected stitch. Some stitches can be changed between two stitch settings (width/positioning) and/or (length/density). This will be indicated by a button symbol in the middle of the stitch control. Toggle between the different stitch settings by touching the button symbol in the middle of the control. The adjustments work just like in sewing mode.

Delete a stitch or letter

If you want to delete a stitch, move the cursor to the stitch you want to delete and touch the delete icon. Use the long touch function to delete the whole sequence.

Replace a stitch or letter

To replace a stitch, simply select it and then touch delete and insert the new stitch. It will be placed at the cursor position.

Sequence commands

You can insert tie-off, stop and thread snip commands into the sequence. These commands will be included in the sequence and will always be performed when sewing it.

Move the cursor to the position where you want to add a command. Select it and an icon will be added into the sequence. This confirms that the command is inserted and it also shows where the command will be performed in the sequence.

Use the tie-off command if you want a secure tie-off. You can insert the tie-off commands anywhere in the sequence.

Insert the thread snip command if you want the machine to tie-off and cut the threads and raise the presser foot.

Insert a stop command if you want the machine to stop. This is useful for example at the end of the sequence if you want to sew it only once or to create a sequence in several rows.

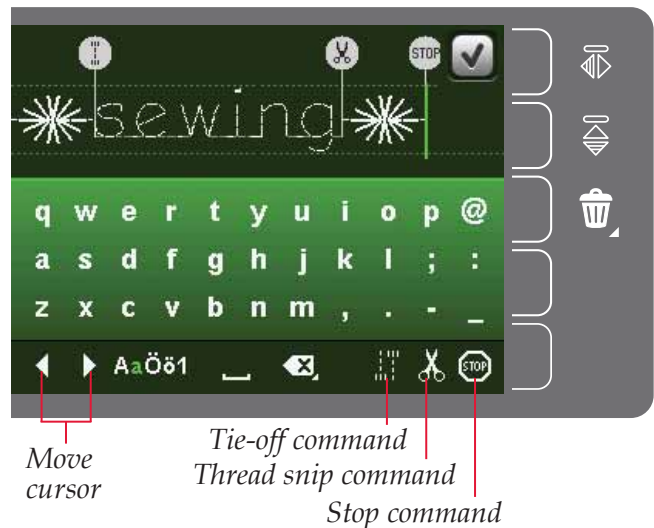
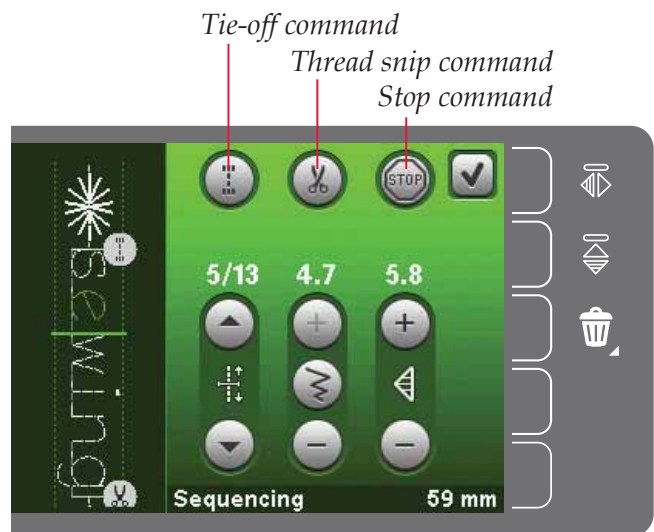
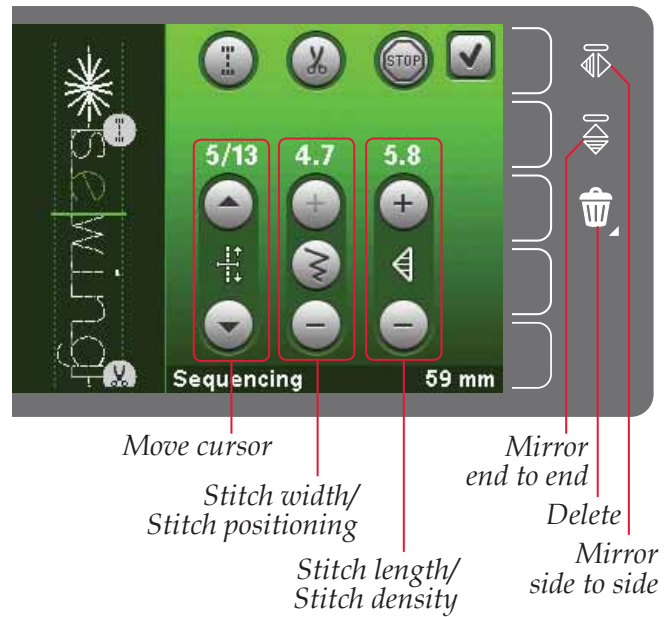

Loading and sewing a sequence

To load the sequence touch OK in the top right corner of the sequencing window. The sequence will be loaded to sewing mode.

Note: You can also close sequencing by pressing the foot control or by pressing the start/stop button.

In sewing mode it is possible to start sewing anywhere in the sequence. Use the arrows to step through the sequence.

If selecting another stitch in sewing mode and then re-opening sequencing, your sequence will remain unchanged. Every time sequencing is closed, the sequence will be loaded to sewing mode.

Adjust the entire sequence

Adjustments made in sewing mode will affect the whole sequence. However, these changes will not be saved if you return to sequencing. To adjust individual stitches in the sequence, return to sequencing.

Saving a sequence

Saving a sequence with your personal sequence adjustments is made in sewing mode. Close sequencing by touching OK in the top right corner of the sequencing window.

Save the sequence by touching the save to personal menu icon. You can scroll through the personal menus to find a free position, using the scroll arrows. Any box without a stitch is a free position and can be used to save your new stitch. Simply touch the position and your stitch is saved.

Any box with a stitch is an occupied position. You can overwrite a previously stored stitch. Simply touch the stitch to overwrite. A pop-up will ask you to confirm that you want to overwrite the previously stored stitch. Cancel the saving process by touching the cancel icon.

Delete a sequence

If you want to delete one stitch, first touch delete (A). A highlighted green delete symbol (B) will appear at the lower right to indicate that delete is active. Then touch the stitch you want to delete. The position will be emptied. To abort the deletion before selecting a stitch, touch the delete icon (A) again. A long touch of the delete icon (A) will empty the whole subcategory selected.



Arrows (move cursor back and forth in the sequence)

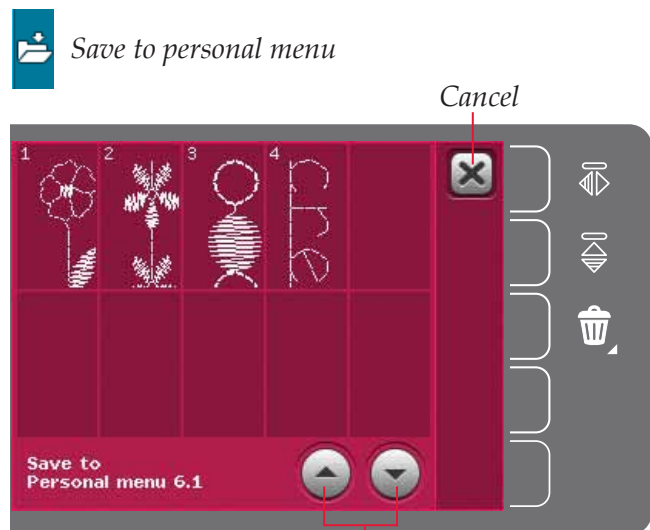

Scroll arrows

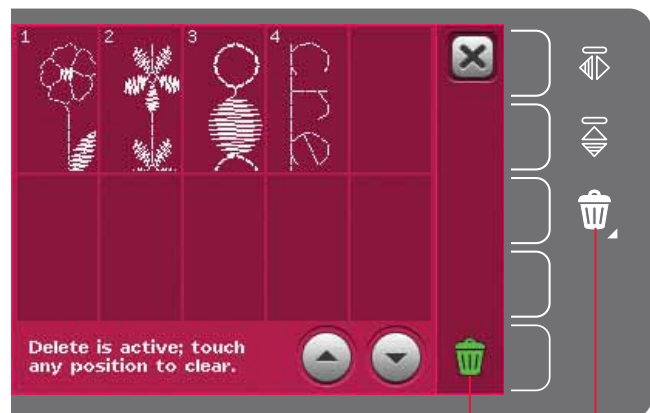

Delete (A)
Delete symbol (B)

Important sequencing information

Sequence adjustments

Adjustments made in sewing mode will affect the whole sequence. However, these changes will not be saved if you return to sequencing. To adjust individual stitches in the sequence, return to sequencing.

Sequences in Stitch Creator™ feature

A sequence can be opened in Stitch Creator™ feature and modified. Note that when doing this, your sequence will become one stitch. When re-opening sequencing, it will not be possible to adjust any part of the former stitches in the sequence any more. The entire sequence will be handled as one stitch.

Common sequencing pop-ups

Not an editable stitch

Some stitches are not possible to insert into a sequence, for example buttonholes.



Sequence out of range

The stitch you are trying to add will make the sequence too long.

Your programmed stitch can be up to approximately 500mm (20") long and contain up to 99 stitches. If the sequence exceeds the maximum length or number of stitches this pop-up will let you know.

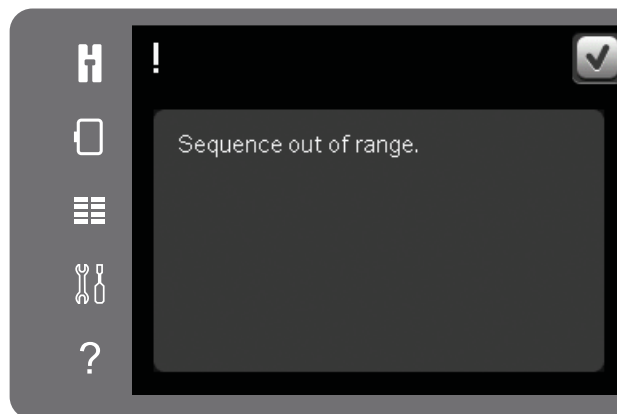



Stitch Creator™ feature 6

Stitch Creator™ feature

In Stitch Creator™ feature, you can create completely new stitches and adjust every single stitch point. Customize and create your own stitches. Add, erase, move and combine stitches directly on screen. You can also insert a built-in stitch, and then edit to create your own version of that stitch.

The width of the stitch field is 9mm and maximum stitch length is 6mm. The grid and the vertical center line will help you to create your stitch. Your stitch can be up to approximately 500mm (20") long and can be stored in your personal menu.

Stitch Creator™ feature - overview

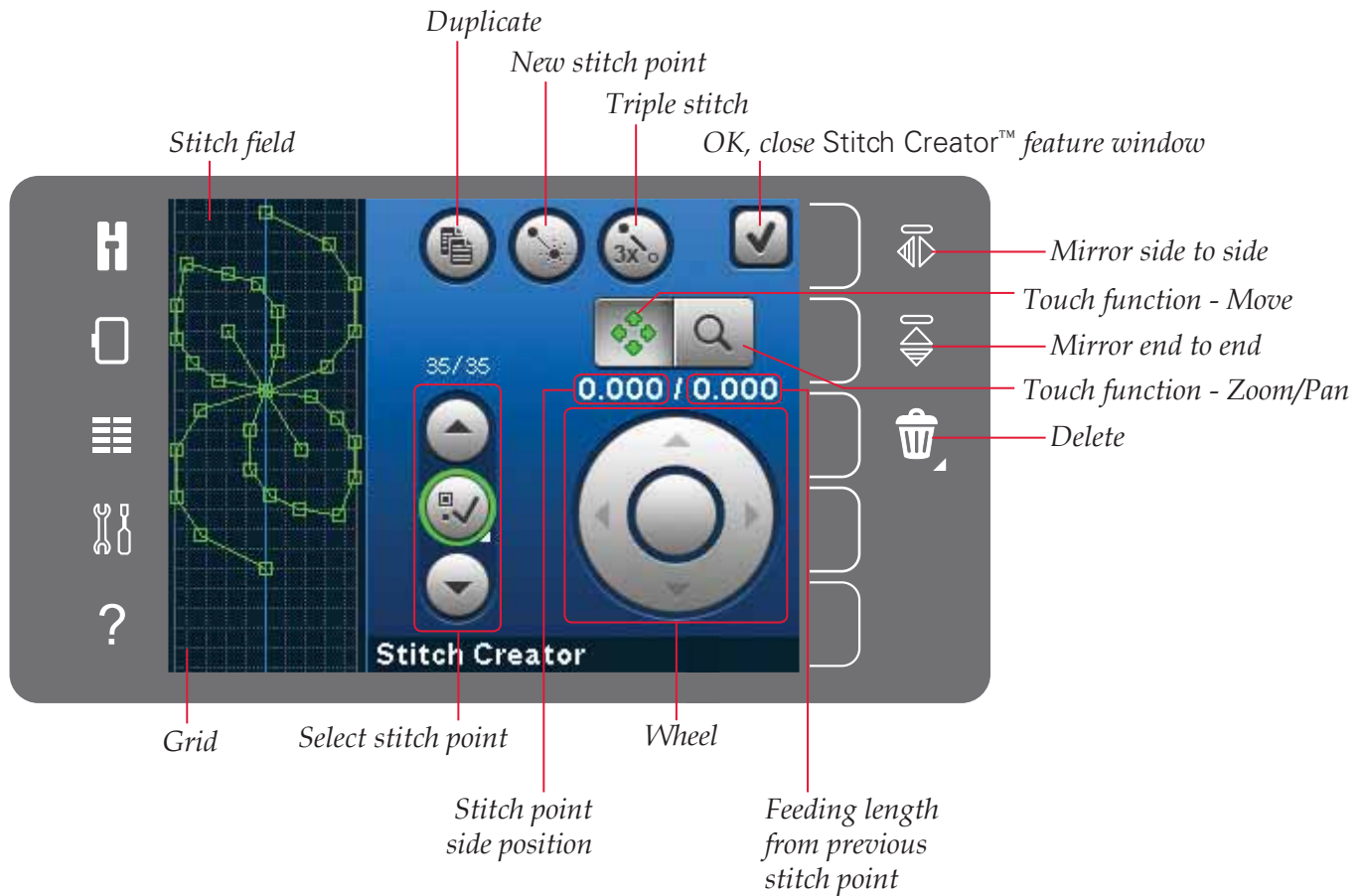

Open and exit Stitch Creator™ feature

To open, just touch the Stitch Creator™ feature icon on the option bar. To close Stitch Creator™ feature and sew your created stitch or combination, touch OK in the top right corner of the screen.

Note: If your programmed stitch is ready to be sewn, you can also close the active function by pressing the foot control, or by pressing the start/stop button.

Some stitches cannot be used with Stitch Creator™ feature. If you try to select one of these stitches, a pop-up will notify you.

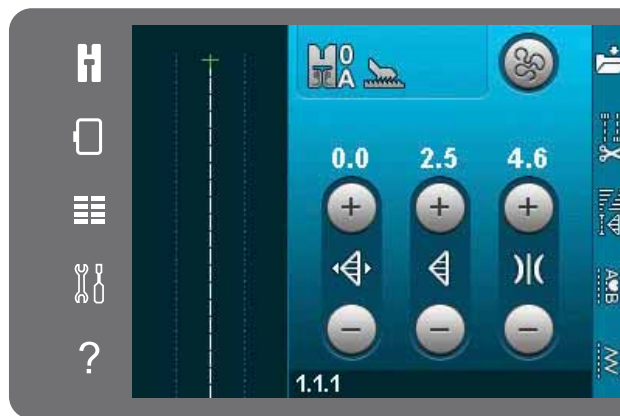

Stitch Creator™ feature

Definition of a stitch point

A stitch point is the point where the needle goes through the fabric. Stitch points are connected by stitches.

Each stitch point is indicated by a green dot. A selected stitch point is indicated by an outlined square. A marked stitch point is indicated by a filled square.

Start creating - add a stitch or stitch point

To add a new stitch point touch the new stitch point icon. You can also add a built-in stitch from the selection menu.

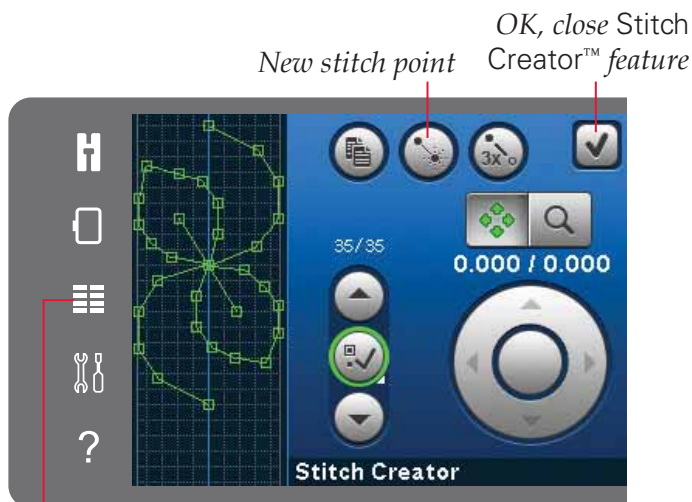

New stitch point

OK, close Stitch Creator™ feature

Selection menu

Select stitch points

To select a stitch point, just touch it on screen with your stylus or use the arrows in the select stitch point control. If selecting more than one stitch point with the stylus, the stitches between the two stitch points will automatically be selected as well, marked with green color (A and B in picture).

You can also select stitch points by activating select stitch point control. First, touch the button symbol in the middle of the control. The button symbol will be surrounded by a green circle to indicate that it is active. Use the up arrow to select stitch points before the marked stitch point and the down arrow to select the stitch points after the marked stitch point.

Note: If selecting stitch points using the up arrow, you can deselect them by touching the down arrow.

The first number above the select stitch point control is the marked stitch point. The second number is the total number of stitch points.



Select stitch point

Duplicate selected stitch point

If you want to duplicate a stitch point(s), select the stitch point(s) and use the duplicate icon to create a copy.

If several stitch points are selected, all stitch points will be duplicated and inserted after the marked stitch point.

Insert a new stitch point

Touch this icon to insert one single stitch point. The two stitch points will create a new stitch.

Triple stitch

Touch the triple stitch icon and the selected stitch(es) will be tripled.

Note: Only enabled if more than one stitch point is selected.

Mirroring side to side

The selected stitch point(s) will be mirrored horizontally.

Mirroring end to end

The selected stitch points will be mirrored vertically.

Note: Only enabled if more than one stitch point is selected.

Delete selected stitch point

If you want to delete a single stitch point, select the stitch point and touch the delete icon. If more than one stitch point is selected, they will all be deleted when touching the delete icon.

Use the long touch function to delete all stitch points in the stitch field.

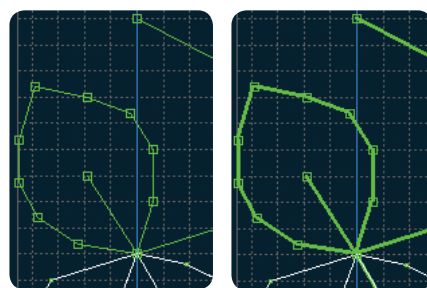
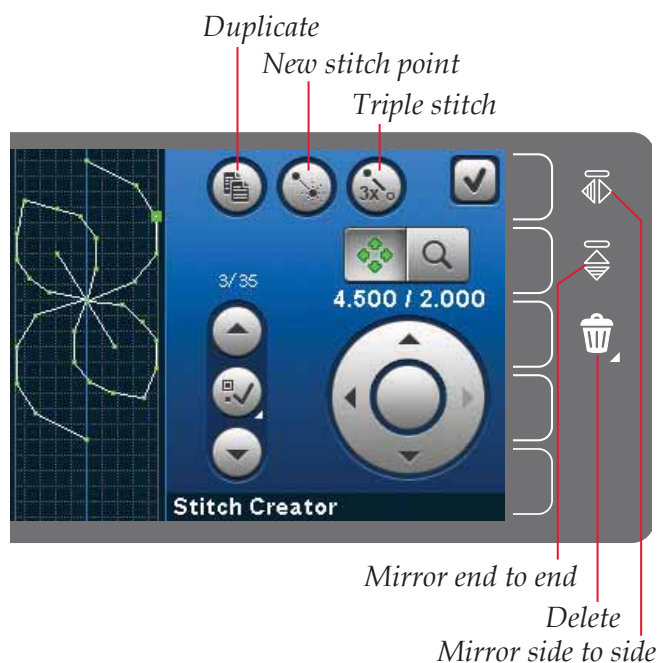

Triple stitch

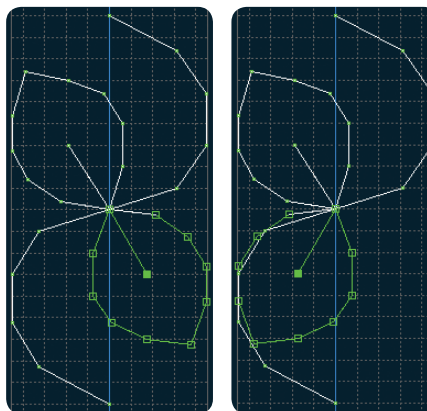

Mirroring side to side

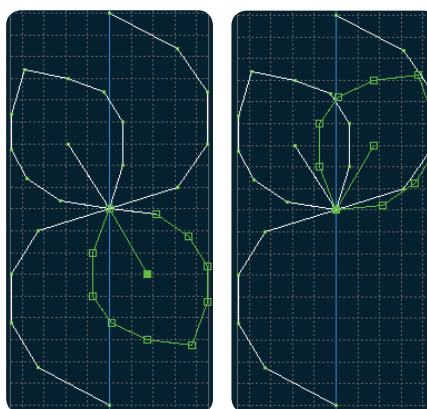

Mirroring end to end

Touch functions

Use your stylus to make changes directly on screen by touching and dragging in the stitch field. You can pan and move depending on which touch function is activated. You can also use the arrows in the wheel to make precise adjustments.

Move

You can move the selected stitch or stitch points using your stylus on the screen or touch the arrows in the wheel.

Zoom/Pan

When using the zoom/pan icon, the focus will be on the marked stitch point. Pan will be active. Use the stylus to pan on the screen.

Note: You can not pan outside the sewing area, i.e. when scale is 100% or less, you can not pan sideways.

The distance between the grid lines equals 1mm on the fabric. Use the arrows in the wheel to zoom in or out. If you zoom in on the stitch field, thinner grid lines will appear. The distance between these lines equals 0.5mm. If zooming out, only the edge lines of the stitch field will be visible.

Position of the marked stitch point

The number to the left above the wheel shows the actual needle position from the center line for the marked stitch point (A).

The number to the right above the wheel shows the actual feeding length from the previous stitch point (B).

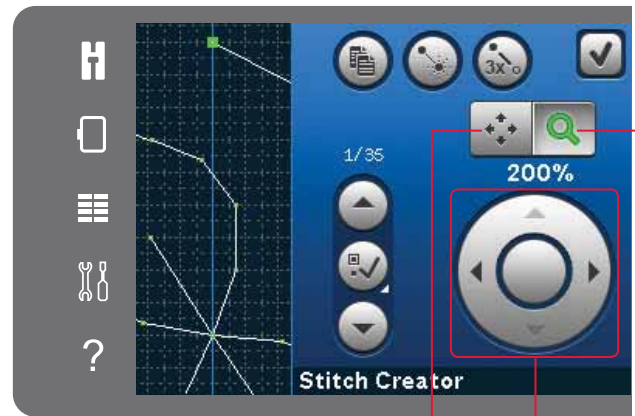

Touch function - Move

Wheel

Touch function - Zoom/Pan

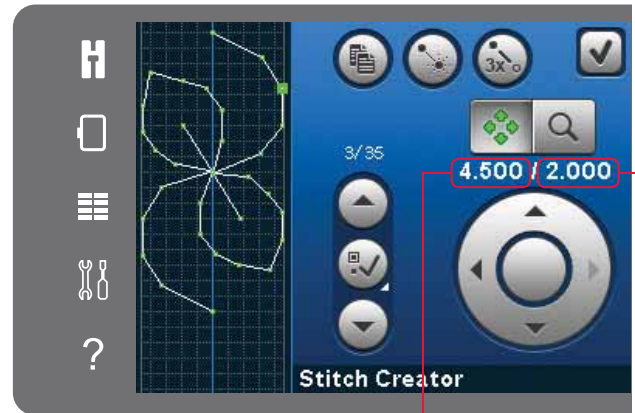
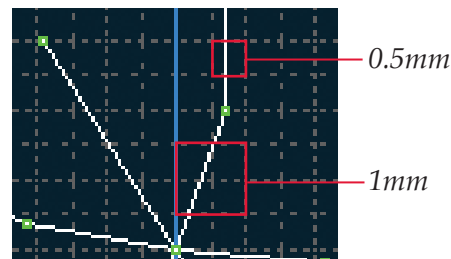

Stitch point side position (A)

Feeding length from previous stitch point (B)

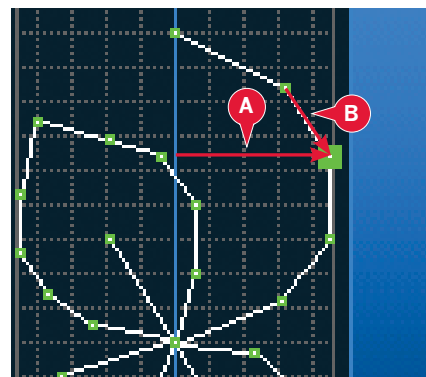

Loading and sewing a stitch

To sew the created stitch touch OK in the top right corner in the Stitch Creator™ feature window. The stitch will be loaded to sewing mode and is ready to be sewn.

If selecting another stitch in sewing mode and then re-opening Stitch Creator™ feature, your created stitch will remain unchanged. Every time Stitch Creator™ feature is closed, the stitch will be loaded to sewing mode.

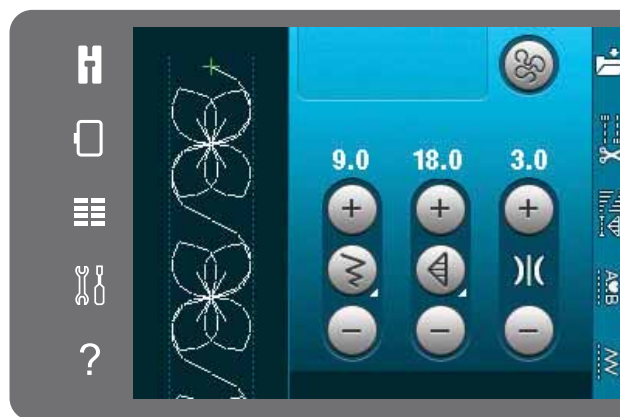

Save to personal menu

Saving a stitch

Saving a stitch is done in sewing mode. Close Stitch Creator™ feature by touching OK in the top right corner of the screen. Save the stitch by touching the save to personal menu icon.

You will find saved stitches in category 6, personal menu. Each subcategory in the personal menu has 10 positions to save your own stitches or sequences. Choose the subcategory you want to save your stitch in. All your previously saved stitches will be shown in the personal menu.

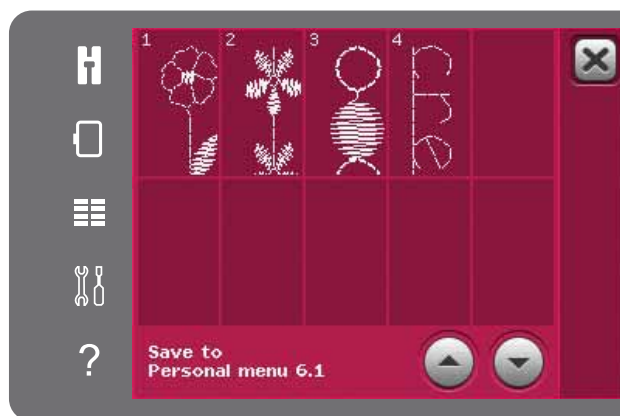

Common Stitch Creator™ feature pop-ups

Not an editable stitch

Some stitches are not available to edit in Stitch Creator™ feature. Buttonholes cannot be opened in Stitch Creator™ feature.



Sequence out of range

Your programmed stitch can be up to approximately 500mm (20") long. If the stitch/sequence exceeds the maximum length this pop-up will let you know.

The stitch or stitch point you are trying to add will make the stitch too long.

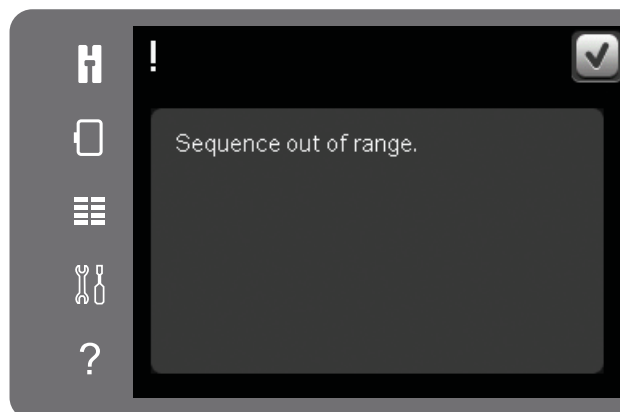



Embroidery mode – 7
preparations

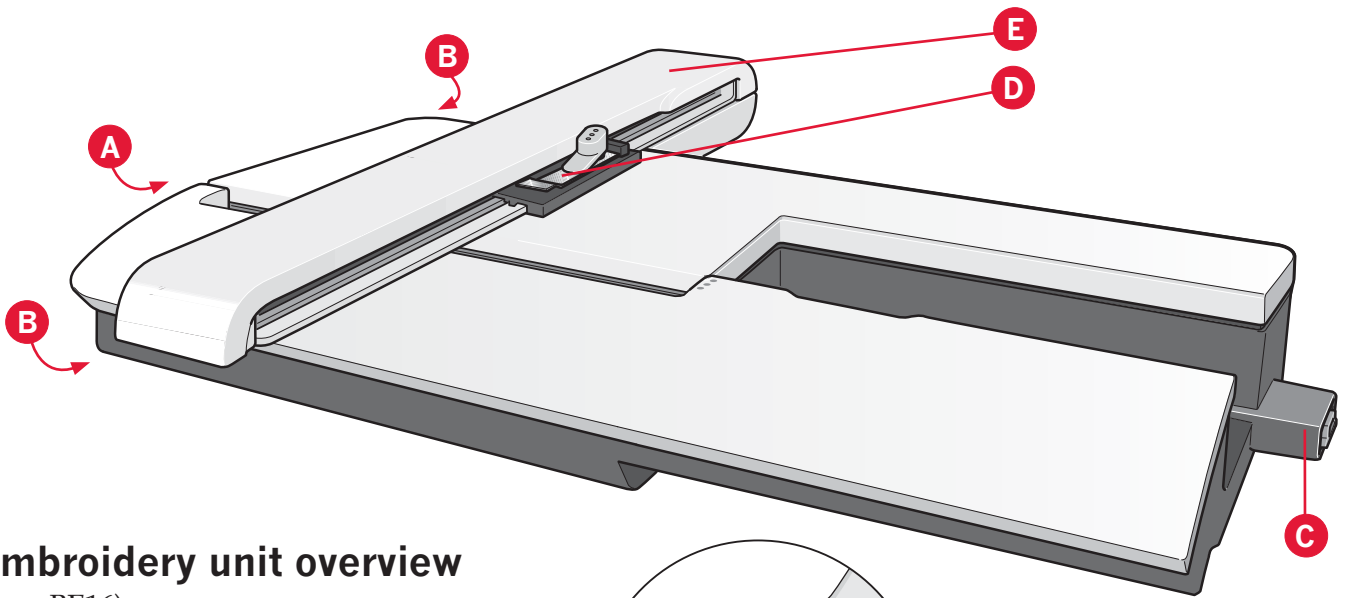

Embroidery unit overview

(type BE16)

- A Embroidery unit release button
- B Level adjusting feet
- C Embroidery unit socket
- D Embroidery hoop connection assembly
- E Embroidery arm

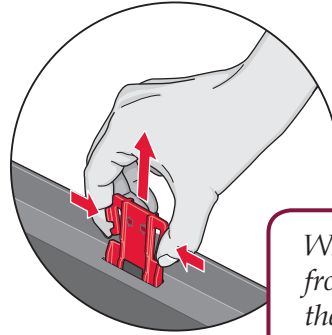

When removing the embroidery unit from the box for the first time, be sure the shipping brace on the underside of the embroidery unit has been removed.

Embroidery hoop overview

- F Embroidery hoop connector
- G Outer hoop
- H Inner hoop
- I Quick release
- J Retaining screw
- K Ribs for fitting the clips
- L Center marks

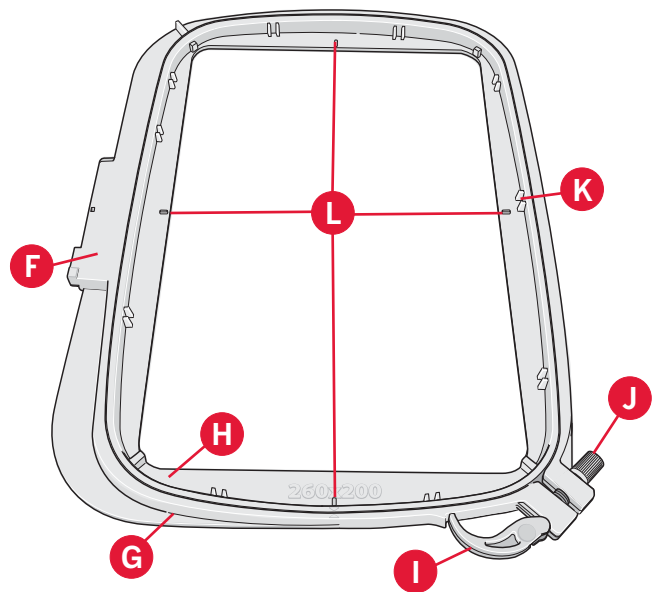

Attach the embroidery foot 6A

When embroidering, use the Embroidery/Sensormatic free-motion foot 6A. See page 2:9 for instructions on how to change presser foot.

Note: You can also use the optional Dynamic Spring Foot 6D (part number 820991-096) when embroidering.

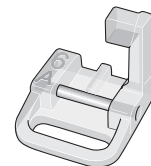

Built-in designs

More than 150 designs are included in the memory in your machine.

creative™ 3.0 Embroidery collection

Page through the creative™ 3.0 Embroidery collection for all built-in designs and fonts.

The design number, stitch count (number of stitches in the design) and the design size are displayed next to each design. The suggested thread color for each color number is shown.

Connect the embroidery unit

There is a covered socket behind the free-arm, see picture. The cover will open automatically when connecting the embroidery unit.

1. Slide the accessory tray off.
2. Slide the embroidery unit onto the free arm of the machine until it plugs firmly into the socket. If needed, use the level adjusting feet so that the machine and embroidery unit are even. If the machine is turned off, turn it on.
3. A pop-up tells you to clear the embroidery area and remove the hoop for positioning. Touch OK. The machine will calibrate and the embroidery arm will move to the ready position. This calibration will set your embroidery functions each time you slide on the embroidery unit.

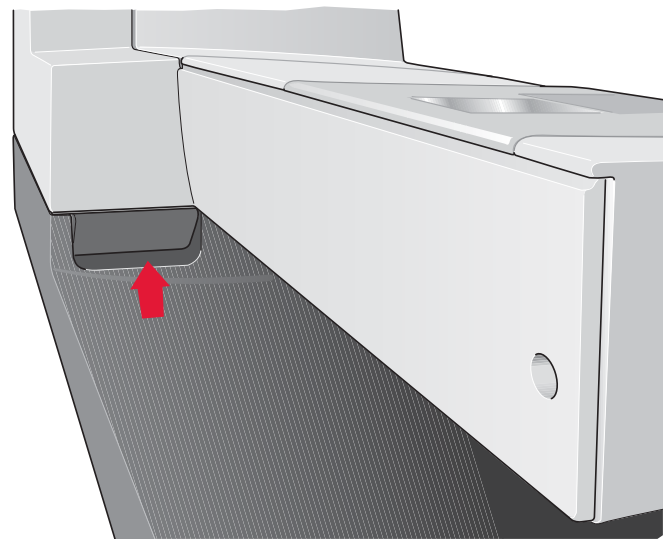

Make sure not to calibrate the machine with the embroidery hoop attached as this can damage the needle, presser foot, hoop and/or the embroidery unit. Be sure to clear all materials from around the machine before calibrating so that the embroidery arm does not bump into anything while calibrating.

Remove the embroidery unit

1. To store the embroidery unit, move the embroidery arm to park position by selecting park position (see page 9:5) on the screen in Embroidery stitch-out.
2. Press the button at the left, underneath the embroidery unit (A) and slide the unit to the left to remove it.

Note: If you switch to sewing mode you cannot start to sew when the embroidery unit is attached.

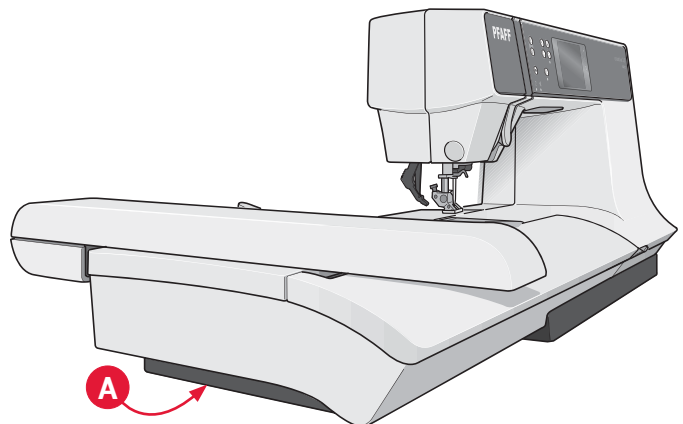

To hoop the fabric

For the best embroidery results, place a layer of stabilizer beneath the fabric. When hooping stabilizer and fabric make sure that they are smooth and securely hooped.

1. Open the quick release (A) on the outer hoop. Remove the inner hoop. Place the outer hoop on a firm flat surface with the screw on the lower right. There is a small arrow in the center of the lower edge of the hoop which will line up with a small arrow on the inner hoop.
2. Place stabilizer and the fabric, with the right sides facing up, on top of the outer hoop. Place the inner hoop on top of the fabric with the small arrow at the bottom edge. If you can see the hoop size in the lower part of the inner hoop, you have attached it correctly (C).
3. Push the inner hoop firmly into the outer hoop.
4. Close the quick release. Adjust the pressure of the outer hoop by turning the retaining screw (B). The fabric should be taut in the hoop for the best results.

Note: When embroidering additional designs on the same fabric, open the quick release, move the hoop to the new position on the fabric and close the quick release. When changing type of fabric, you might need to adjust the pressure using the retaining screw. Do not force the quick release.

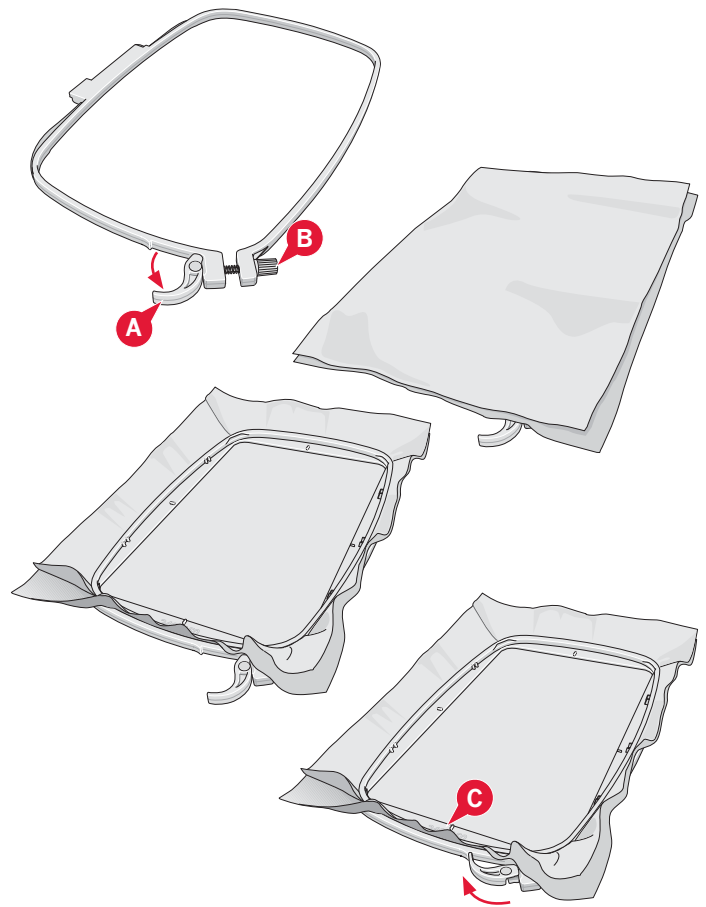

Slide on/off the hoop

Slide the hoop onto the embroidery unit from front to back until it clicks into place.

To remove the hoop from the embroidery arm, press the grey button on the hoop connection assembly and slide the hoop towards you.

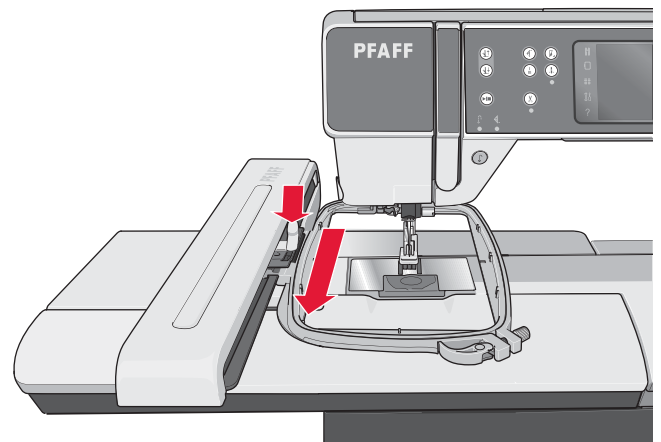
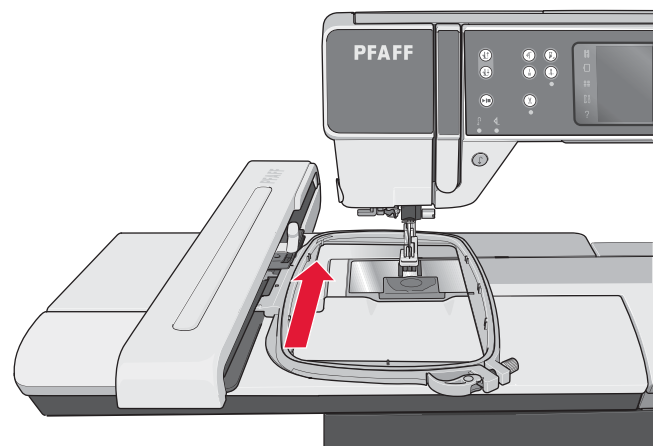

Getting started embroidering

1. After attaching the embroidery unit and embroidery foot, insert a bobbin with lightweight bobbin thread.

Note: Make sure that the IDT™ system is disengaged.

2. Touch embroidery mode icon to go to Embroidery edit. To select a built-in design, open the selection menu and touch the designs icon. Locate desired design and touch it once to load to Embroidery edit.

You can also load a design from an USB device or from personal files. Touch USB device or personal files to locate your design and long touch the design to load it.

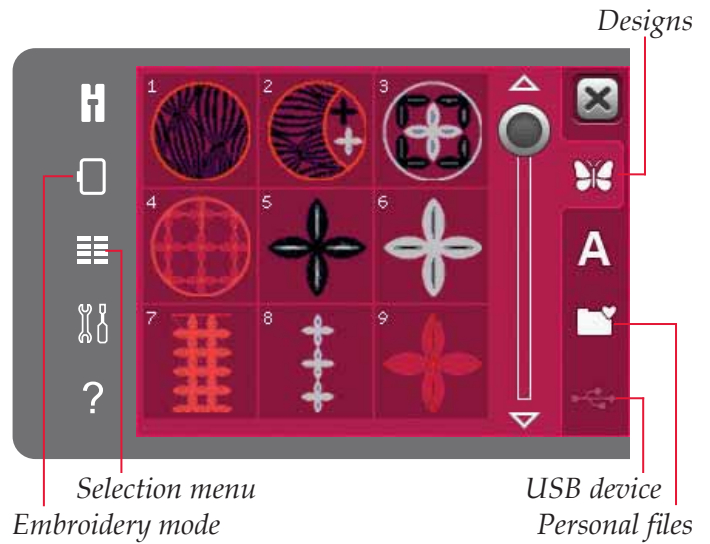

3. The design is placed in the center of the hoop.
4. Switch from Embroidery edit to Embroidery stitch-out by touching the Embroidery stitch-out icon on the option bar.

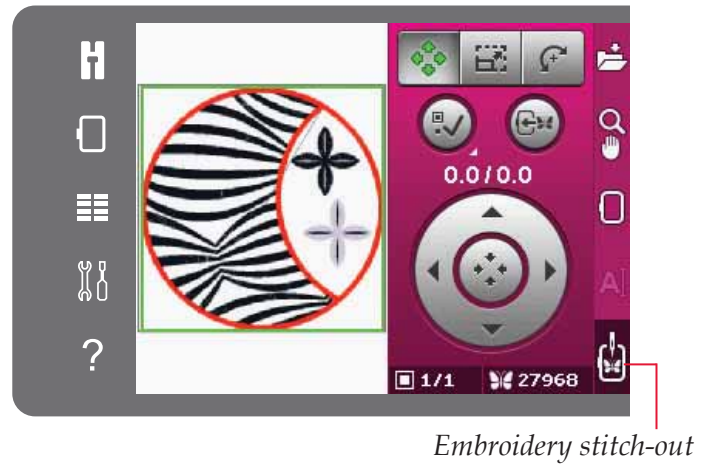

5. When entering Embroidery stitch-out mode, a pop-up will appear on the screen. Thread the machine with the color that is displayed in the pop-up.

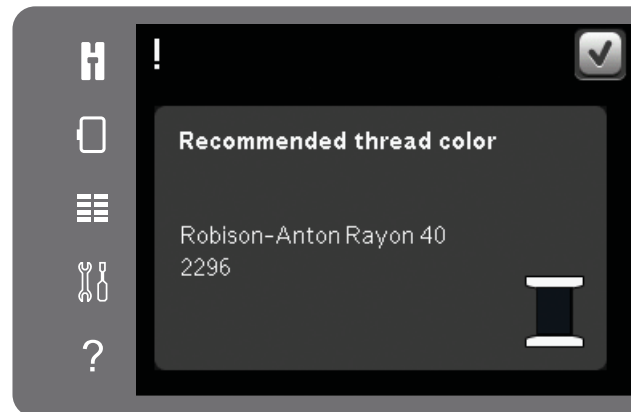

6. Prepare recommended hoop with fabric and stabilizer. Attach the hoop to the embroidery arm.

7. Clear sufficient space to accommodate movement of the embroidery arm and the hoop. Hold the needle thread and touch the start/stop button or the foot control. The machine starts embroidering.

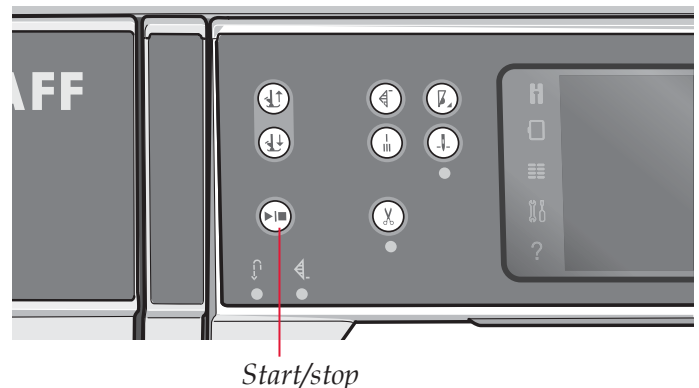

Note: This machine features the automatic function *Cut jump stitches*. When activated the machine trims the top jump stitch threads and pulls the thread ends to the underside of the fabric. The default setting is on. To turn it off, go to the Settings menu, Embroidery settings and deselect *Cut jump stitches*. Read more about *Cut jump stitches* in chapter 3.

8. If *Cut jump stitches* is not activated the machine will stop after stitching a few stitches. A pop-up appears on the screen asking you to cut the thread end. Cut the thread and press start/stop to continue embroidering.



9. While you embroider, you can touch color list to see all colors in the design. The active color block is marked with a green frame (A).

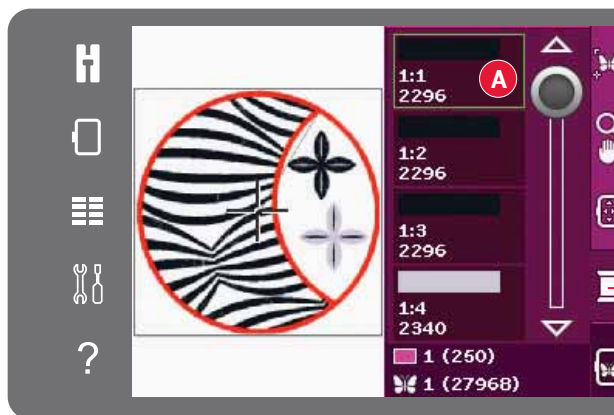

Color block list

10. When the first color is complete, your machine stops. Re-thread with the recommended thread color that is displayed in the pop-up and continue embroidering by pressing start/stop. Each color segment is tied off at the end and the needle thread is cut.

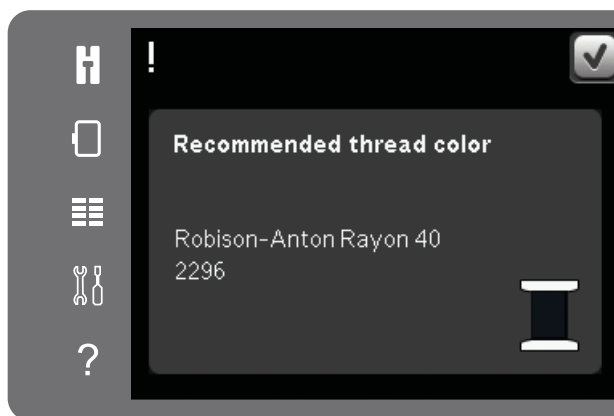

11. When the embroidery is completed, your machine cuts the needle and bobbin thread and stops. The needle and presser foot raise automatically for easy removal of the hoop. A pop-up informs you that your embroidery is finished. Touch OK to keep the design loaded and stay in Embroidery stitch-out.

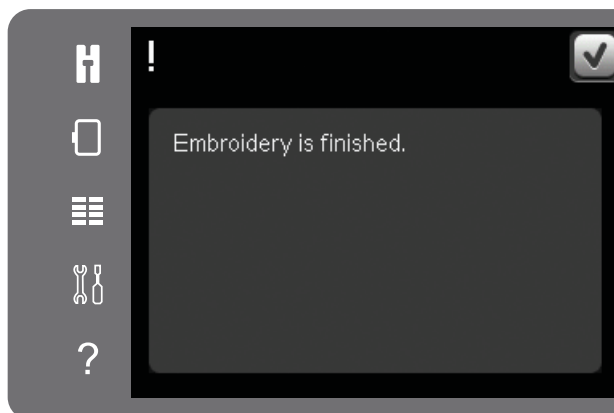



Embroidery mode – edit 8

Embroidery mode - edit

Touch the Embroidery mode icon to enter Embroidery edit. If you turn on the machine with the embroidery unit attached, Embroidery Edit will be opened automatically. In Embroidery edit you can adjust, combine, save and delete designs. You do not need to have the embroidery unit connected to your machine to edit your designs. The loaded design(s) are shown in the embroidery field.

Embroidery edit - overview

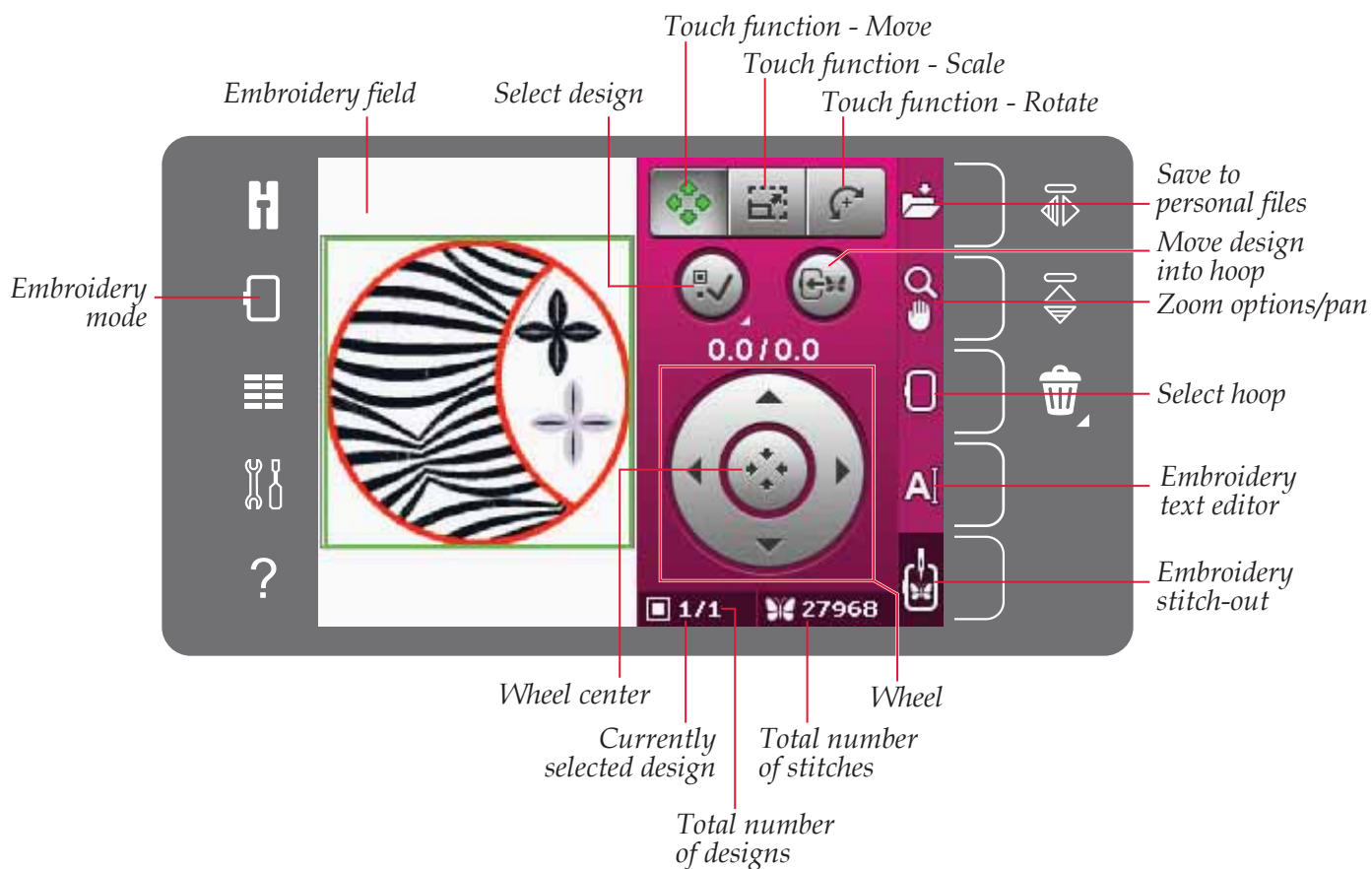

Selection menu

In Embroidery mode the selection menu contains a selection bar at the right with options for designs, embroidery fonts, personal files and USB device.

Select one of the options in the selection bar to access the menus. When a design or font is selected, the selection menu will close automatically. To return to previous view, close by touching cancel.

Load a design

To load a design, open the selection menu. Select the designs tab from the selection bar. Use the scroll bar to browse through all built-in designs. Touch a design to select and load it to Embroidery edit.

The creative™ 3.0 Embroidery collection that comes with your machine includes all built-in designs and fonts.

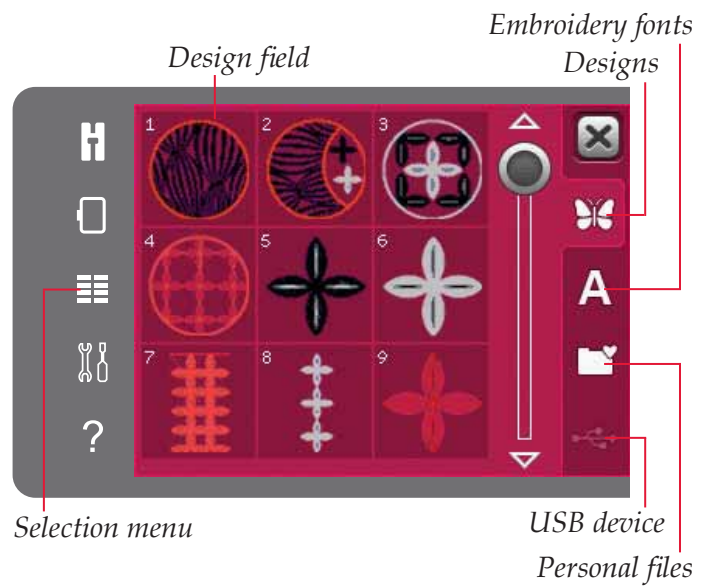

Load a font

Text can be created with embroidery fonts. To load an embroidery font, open the selection menu. Select embroidery fonts tab. Use the scroll bar to browse through all built-in embroidery fonts. Your machine contains two built-in embroidery fonts. The number to the right of each font shows the font size. A selected embroidery font opens in embroidery text editor. Read more about embroidery text editor on page 8:7.

Note: Embroidery fonts are only visible if embroidery mode is active.

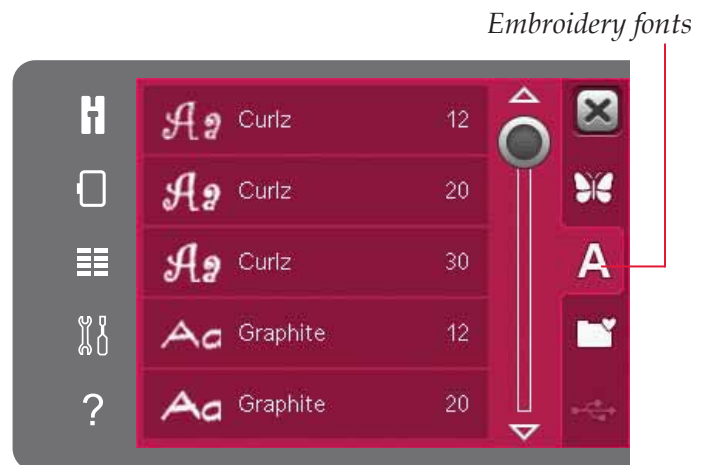

Load from personal files/USB device

To load a design or font from personal files, touch personal files tab. Locate your design or font and long touch to load it and close selection menu.

You can also load a design or font from an USB device. Touch USB device to locate your design or font and long touch to load and close selection menu.

Read more about personal files and USB device in chapter 10.

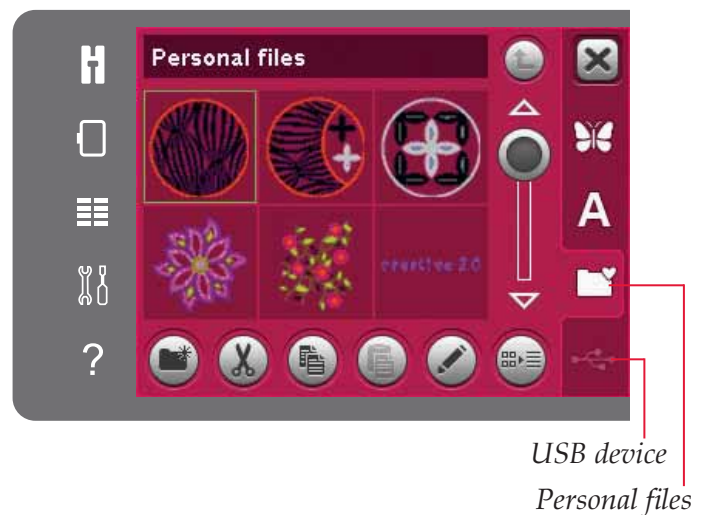

Touch functions

You can use your stylus to make adjustments directly on screen, by touching and dragging in the embroidery field. You can move, scale and rotate, depending on which touch function is active. You can also use the arrows in the wheel to fine tune.

Move

When move is active, you can move the design(s) anywhere in the embroidery field. The numbers above the wheel show in millimeters how far the design has been moved from the center of the hoop, both horizontally and vertically.

Touch the wheel center icon and the design(s) will be moved to the center of the hoop.

Scale

When scale is active, you can increase or decrease the size of the design without changing the total number of stitches. By default, the proportions are locked. This is shown with the closed padlock in the wheel center icon. To unlock, just touch the padlock. Height and width can now be changed individually.

If you move the stylus on the screen towards the center of the selected design(s), the size will decrease. If you move the stylus from the center of the selected design(s), the size will increase. Use the wheel to fine tune. Above the wheel you can see the new width and height of the design. Touch Original size icon to reset the design to its original size.

Rotate

When rotate is active, the selected design(s) will be rotated around the center point of the selected design(s).

Use the arrows in the wheel to rotate the design(s) in one degree steps. Each touch of the wheel center icon will rotate the design(s) 90 degrees clockwise.

Above the wheel you can see how many degrees the design(s) has rotated from its original position.

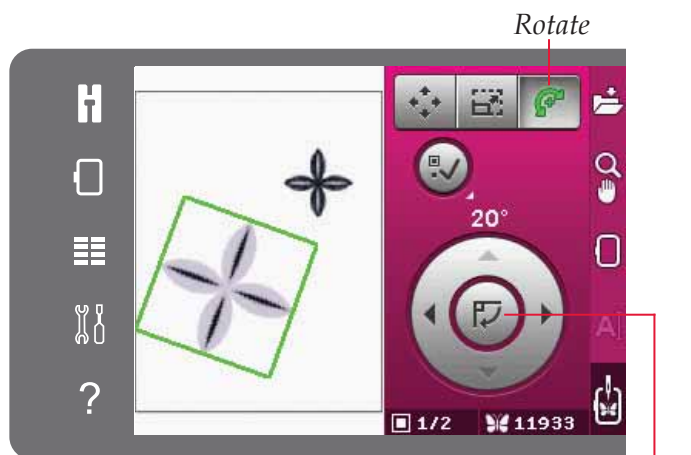
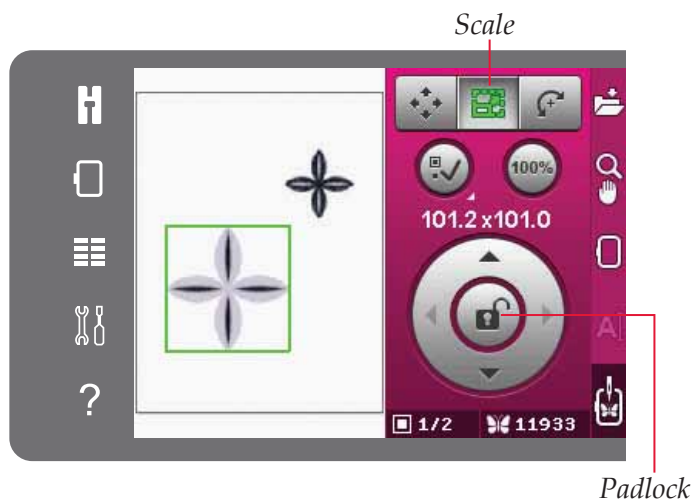
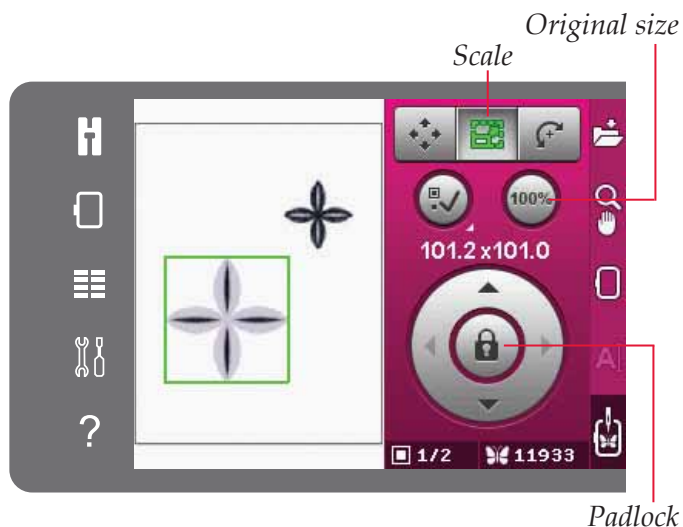
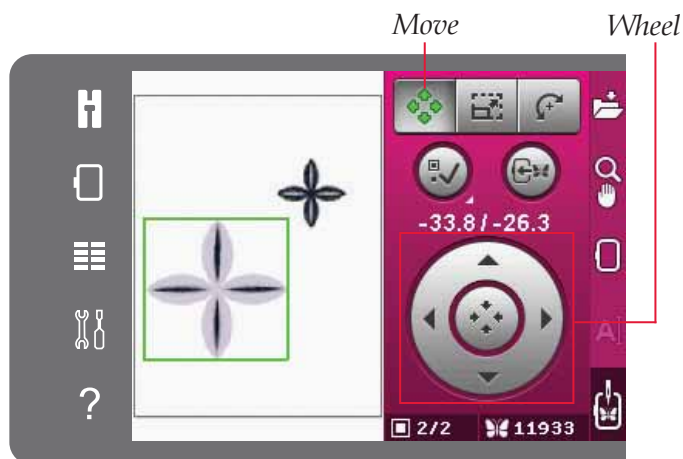

Select design

When loading a design into Embroidery edit, the design is selected by default. If you load another design, the last loaded design will be selected. The select design icon will automatically be activated when loading designs into the embroidery field.

Everytime you touch the select designs icon, you will select the next design in the order in which they were loaded.

A long touch on the select design icon will select all designs in the embroidery field. Touch outside a design in the embroidery field to deselect the design.

Note: To edit a design in the embroidery field, the design needs to be active by being selected.

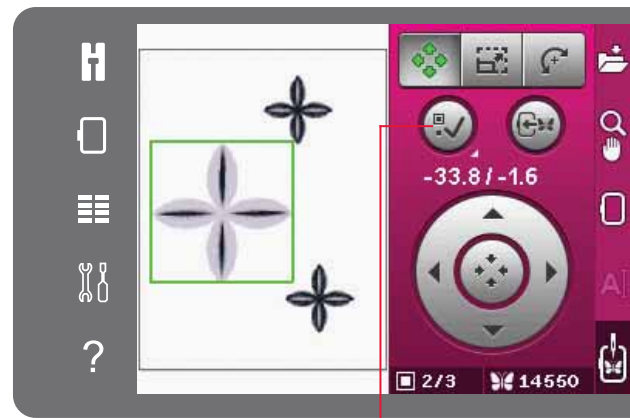

Select design

Move design into hoop

This is used to move any design that is outside the hoop area into the hoop area. The design will be placed as close to the previous position as possible.

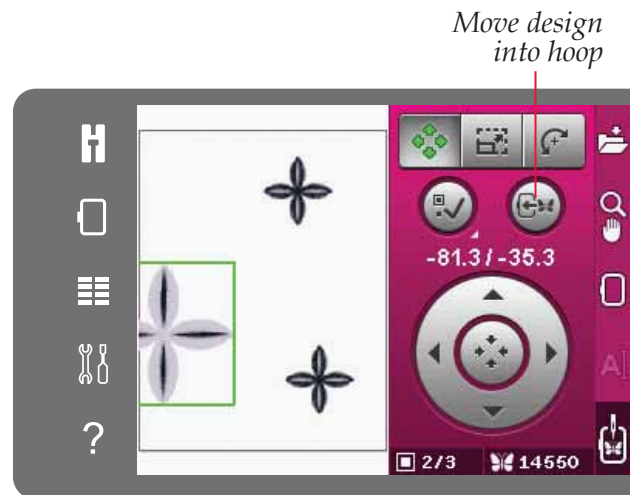

Move design into hoop

Mirror a design

To mirror a design horizontally, touch the mirror side to side icon. To mirror vertically, touch the mirror end to end icon.

Delete a design

To delete a design from the embroidery field, select desired design and touch delete icon.

Long touch the delete icon to delete all designs in the embroidery field. A pop-up window for confirmation will appear.

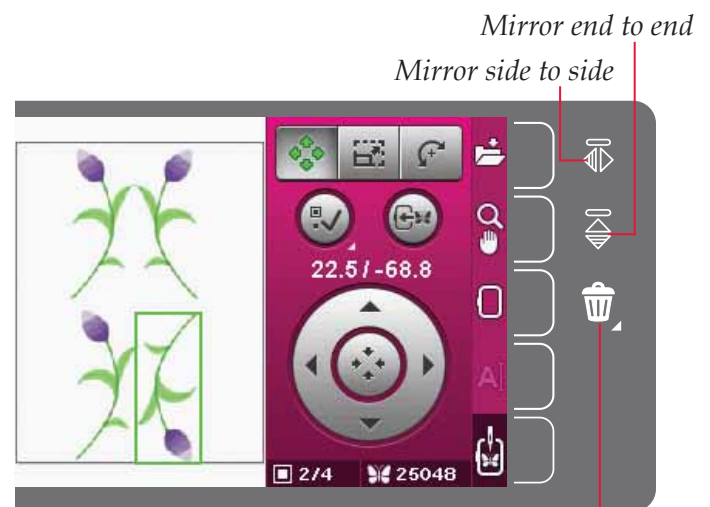

Delete

Option bar in embroidery edit

To the right of the screen you have an option bar where you can save, zoom, select hoop, edit an embroidery text and toggle to Embroidery stitch-out.

Note: The grey field to the right of each icon is a touch field to make it easier to select in the option bar.

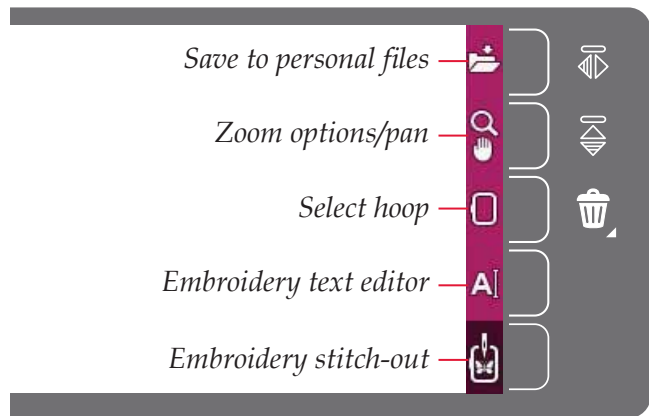

Save to personal files

To save a design into your personal files, touch the save to personal files icon. A new window will open where you can select where to save your design. You can save either in your personal files or to an USB device. You can also create folders to organize your designs.

To change the name of the design, touch the rename icon and change the name. Touch OK to confirm the save. If you want to abort the save, touch cancel and you will return to Embroidery edit.

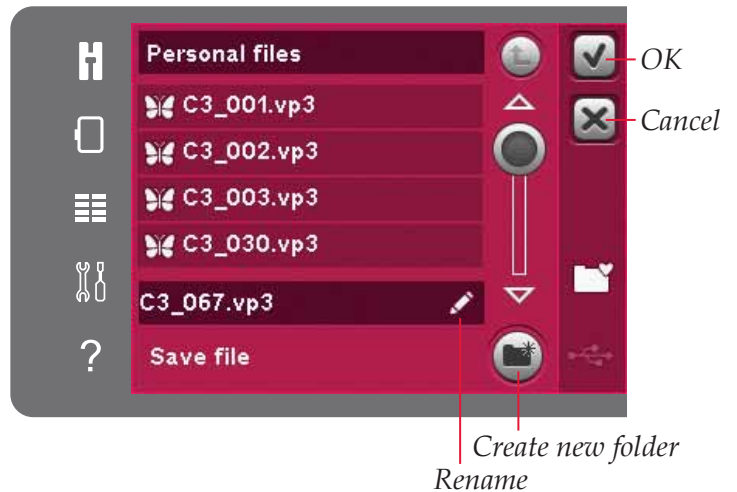

Zoom options/pan

Touch the zoom options/pan icon to open a foldout with zoom options. Use the + and - icons to zoom in or out in the embroidery field. The adjustments will be shown in percent. Pan is always active when zoom options/pan tab is active.

Zoom to box lets you decide how much and where to zoom in the embroidery area. First, select zoom to box. The zoom to box icon will be surrounded by a green circle, indicating that zoom to box is active. In the embroidery field on the PFAFF® creative™ Color Touch Screen, touch and drag with your stylus to define the area to be zoomed. Zoom to box icon will then be deactivated.

Zoom to all will show all the designs in the embroidery combination as large as possible.

Zoom to hoop will adjust the view to show the selected hoop.

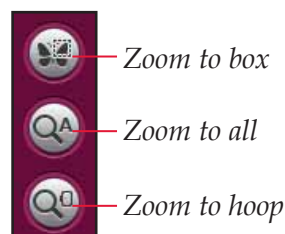
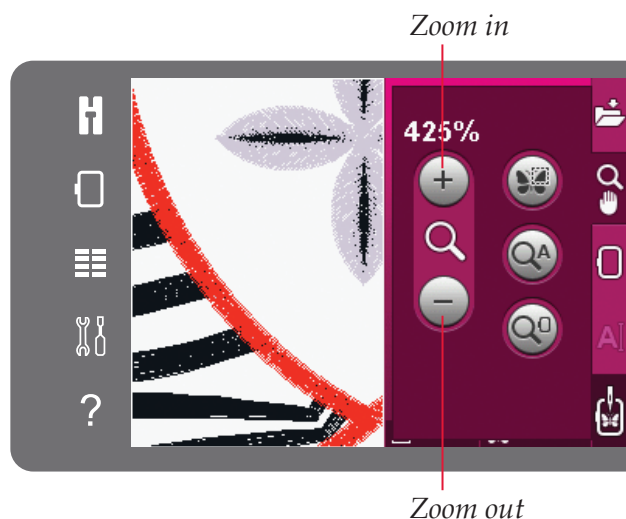

Select hoop

To select the correct hoop size, touch the hoop selection icon. A foldout will appear with the hoop choices, including hoops that are available to purchase from your authorized PFAFF® dealer. Use the scroll bar to view more available hoops.

After selecting your hoop size, the list will close automatically.



Embroidery text editor

When you have created text with embroidery fonts, you may want to adjust the existing text in Embroidery edit. Select the text and touch the embroidery text editor icon on the option bar. Use the stylus and touch the letters you want to add to the text. The text is shown in the text area with the cursor at the active letter. Use the arrows to step forward and backward. Touch character style icon to select upper or lower case letters, numbers and special symbols. Touch OK to return to Embroidery edit and your text will be shown in the embroidery field.

Add letter into a text

Use the arrows to move the cursor to where you want to add a letter. Touch the letter and it will be inserted at the cursor position.

Delete a letter

To delete one letter, place the cursor after the letter to be deleted. Touch the delete icon. If you want to delete all the text you have written, long touch the delete icon. A pop-up will ask you to confirm the deletion.

Embroidery stitch-out

To embroider your design(s), enter Embroidery stitch-out. Make sure the embroidery unit is connected. Toggle to Embroidery stitch-out by touching the Embroidery stitch-out icon on the option bar.

A| Embroidery text editor

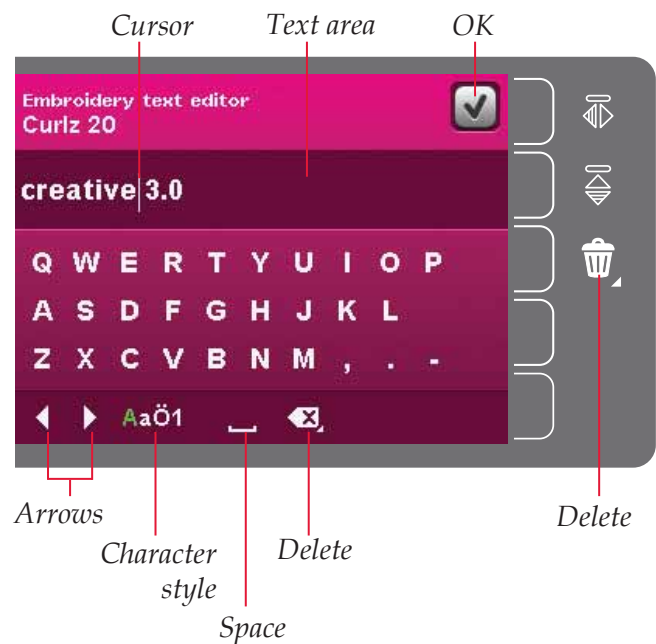

A| Embroidery stitch-out

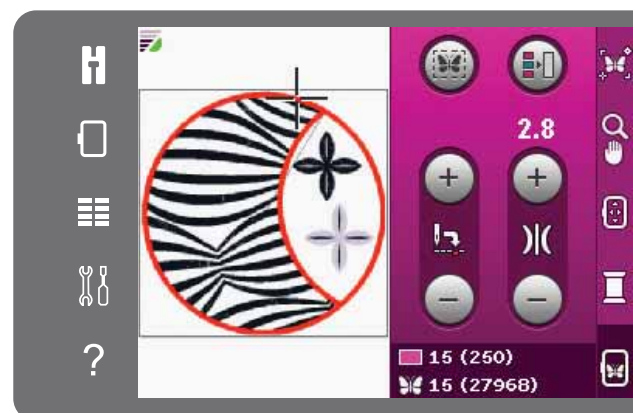

Embroidery stitch-out mode

Embroidery edit pop-ups

Remove hoop

This pop-up will appear when a function has been chosen that forces the embroidery unit to move outside the limits for the attached hoop. In order for the embroidery arm to move freely, remove the hoop and then touch OK. To abort the function touch Cancel.

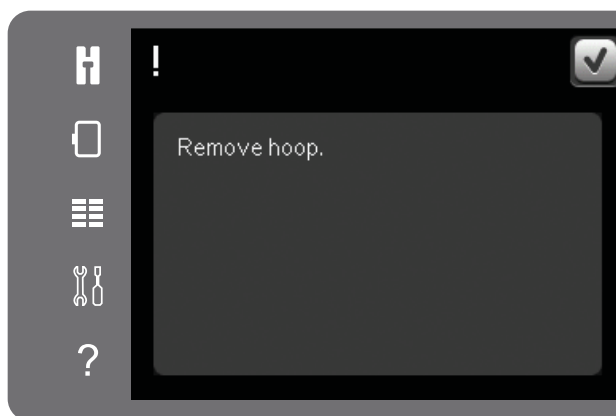

Embroidery combination is too complex

This pop-up appears for one of the following reasons:

- The design combination contains too many color blocks.
- There are too many designs in the combination.
- The design combination you are trying to make contains too many stitches. Your design combination can have up to approximately 500.000 stitches.

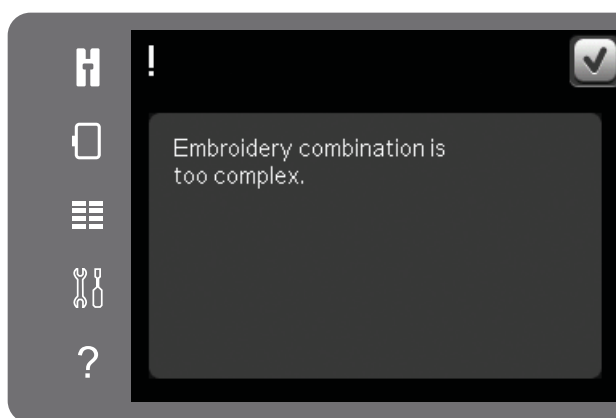



Embroidery mode – stitch-out 9

To enter Embroidery stitch-out

To embroider your design(s), enter Embroidery stitch-out. Make sure the embroidery unit is connected before entering Embroidery stitch-out.

Embroidery stitch-out - overview

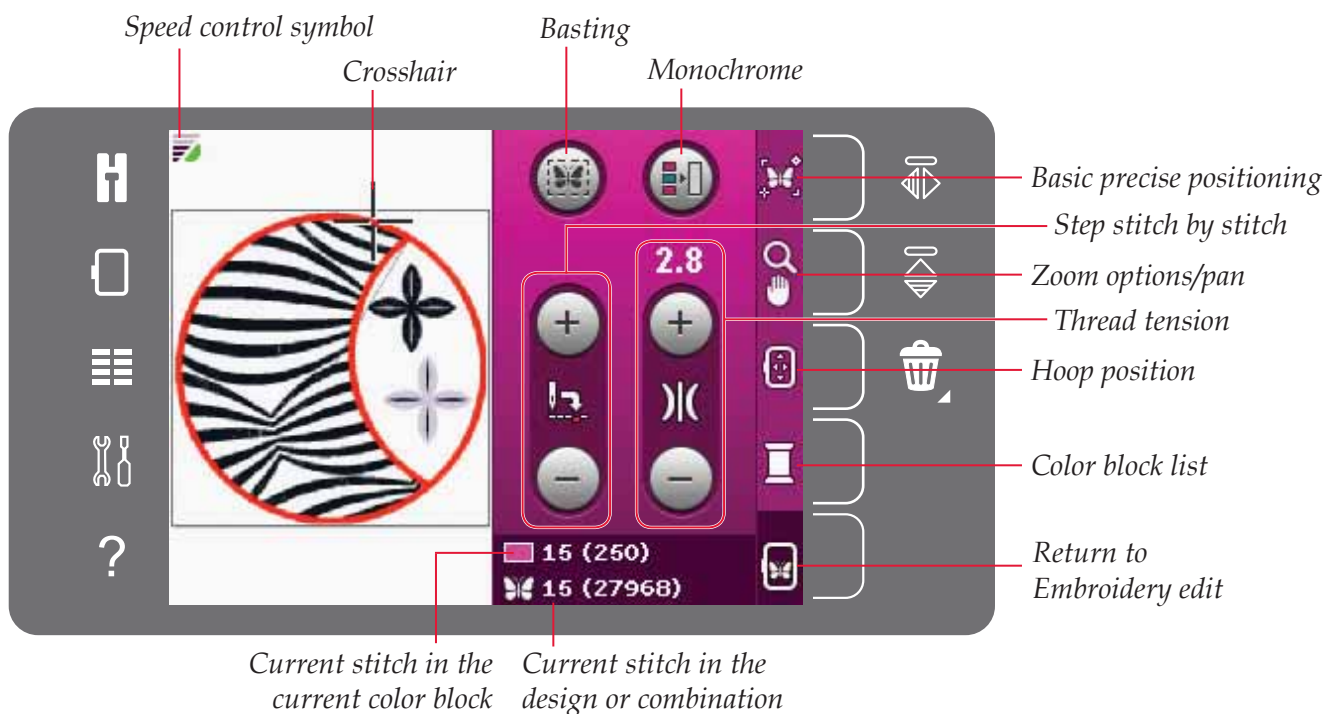

Speed control

This function enables you to easily reduce the embroidery speed. Just touch the speed control button placed at the front of the machine, to reduce the speed. To return to maximum speed, deselect the button.

You can change the speed limit on your machine. Long touch the speed control button to get a pop-up. Set desired speed limit using the scroll, then close the pop-up. Once you touch the speed control icon, the speed will be reduced to the limit you have chosen. When a limit speed is active, a speed control symbol will be shown at the top left corner in embroidery mode.

Note: You can embroider without closing the pop-up.



Speed control button

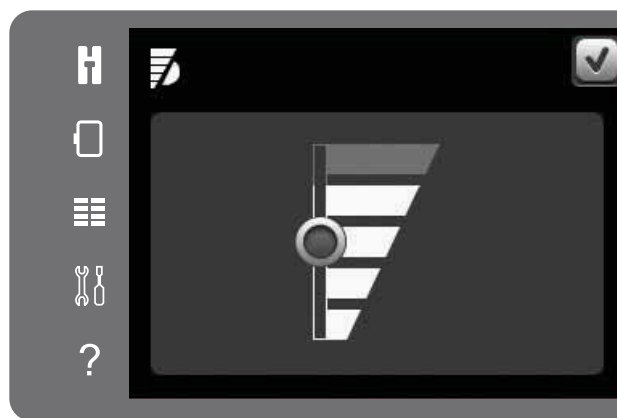

Speed control symbol in the top left corner in Embroidery stitch-out

Crosshair

When embroidering, a crosshair indicates current needle position on the screen.

Basting

Basting enables you to secure your fabric to a stabilizer placed under it. It is especially useful when the fabric to be embroidered cannot be hooped. Basting provides support for stretchy fabrics.

Touch the basting icon to activate basting. The machine will add a basting stitch around the design area, outlining the area where the design will be placed on the fabric.

Note: The color block list cannot be opened while basting is activated and performed.

Monochrome

Touch the icon to activate monochrome embroidery. All designs are shown in a grey color and the machine does not stop for color block changes. To deactivate monochrome embroidery, touch the icon again.

Step stitch by stitch

Touch + to step forward and - to step backwards stitch by stitch. Use the - icon to move backwards a few steps if the needle thread breaks or runs out. Touch and hold to move through the stitches quickly. The crosshair will follow the stitches in the embroidery field.

Thread tension

When embroidering with specialty thread or fabric you may need to adjust the thread tension to achieve the best result. Thread tension can be adjusted up or down using the + and the -. Once you have increased or decreased the thread tension, the numbers above the control will change its color.

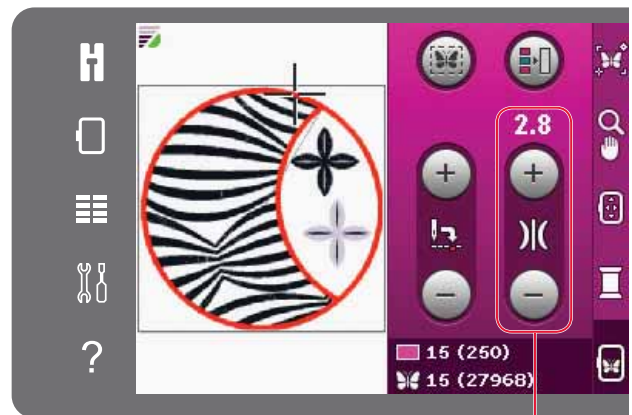
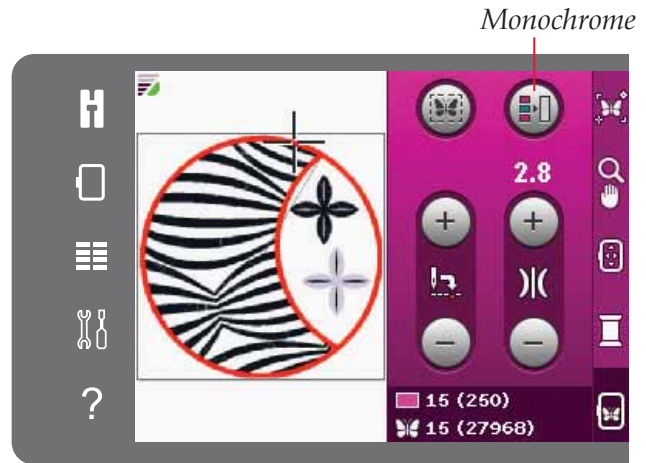
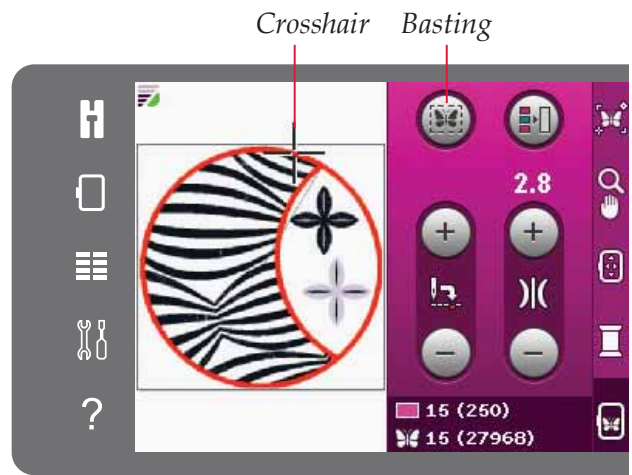

Embroidery information

The current stitch in the current color block is shown next to the color block symbol. The number in brackets shows the total number of stitches in the current color block.

The current stitch in the design or combination is shown next to the butterfly symbol. The number in brackets shows the total number of stitches in the design or combination.

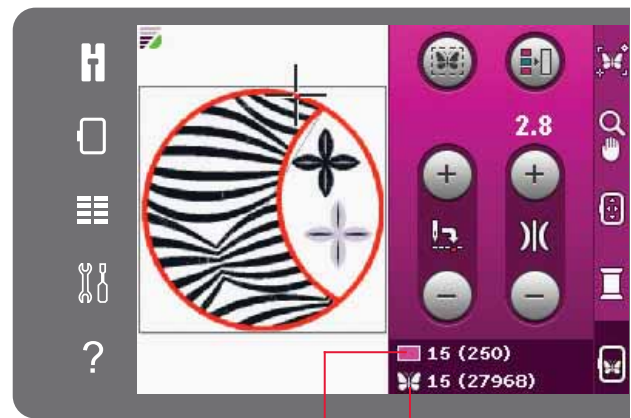

Current stitch in the current color block Current stitch in the design or combination

Option bar

To the right of the screen is an option bar with the following selections: basic precise positioning, zoom options/pan, hoop position, color block list and return to Embroidery edit.

Note: The grey field to the right of each icon is a touch field to make it easier to select in the option bar.

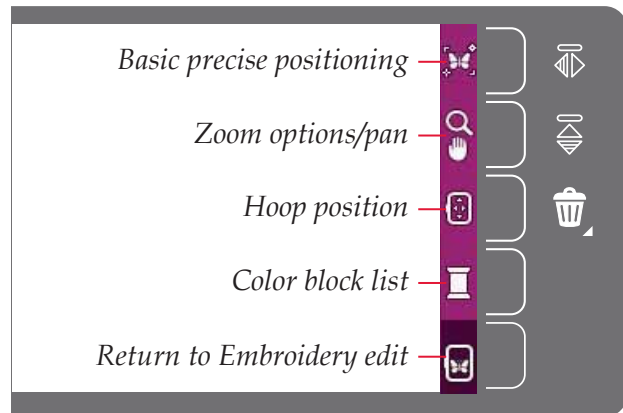

Basic precise positioning

Basic precise positioning allows you to place a design on an exact spot on your fabric. It is also used when you want to embroider a design next to a previously embroidered design.

Use zoom options/pan to be sure that you are placing the design exactly where you want it. Fine tune with the wheel.

Read more about how to use basic precise positioning on page 9:7.

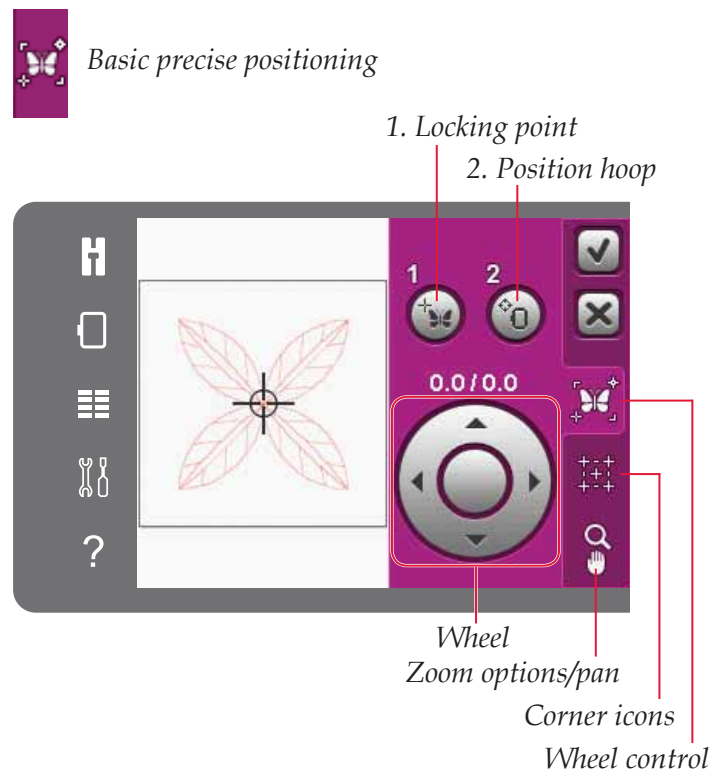

Zoom options/pan

Touch the zoom options/pan icon to open a foldout with zoom options. Use the + and - icons to zoom in or out in the embroidery field. The adjustments will be shown in percent. Pan is always active.

Zoom to box lets you decide how much and where to zoom in the embroidery area. First, select zoom to box. The zoom to box icon will be surrounded by a green circle, indicating that zoom to box is active. In the embroidery field on the PFAFF® creative™ Color Touch Screen, touch and drag with your stylus to define the area to be zoomed. Zoom to box will then be deactivated.

Zoom to all will show all the designs in the embroidery combination as large as possible.

Zoom to hoop will adjust the view to show the selected hoop.

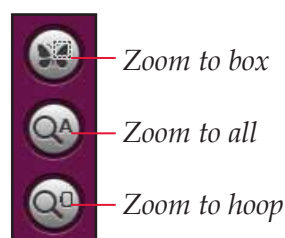

Hoop position

Use the hoop position functions to move the hoop to different positions.

Current position

When you want to return to the current stitch and start embroidering again where the embroidery was interrupted, touch the current position icon. You can also press the start/stop button once to return to the current stitch and start to embroider.

Park position

When you have finished your embroidery, remove the hoop and select park position. The embroidery arm will be placed in a position that will allow easy storage.

Note: It is very important that the hoop is removed, otherwise it may be damaged.

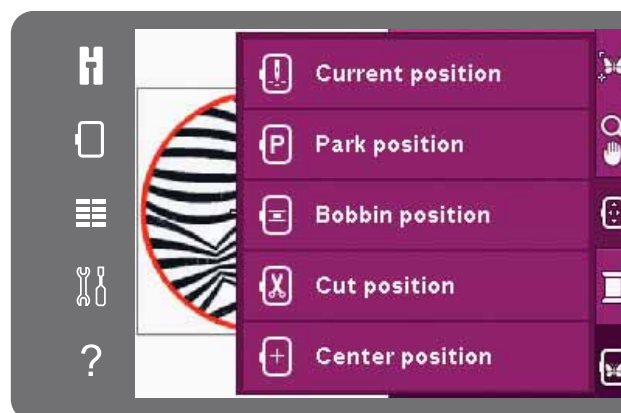

Bobbin position

To make it easier to change the bobbin, touch bobbin position. The hoop will move backwards, allowing you to open the bobbin cover and replace the empty bobbin.

Cut position

Cut position will move the hoop towards you making it easier to cut jump stitches and trim fabric when embroidering, e.g. an appliqué.

Center position

Use the center position if you want to check where the center position of the hoop will be placed on the fabric.

Color block list

All colors in the loaded design(s) are shown in the order they will be embroidered. Each listed color shows color order and number. Use the scroll bar to see all of the colors in the list. Touch a color block in the color block list to set the current stitch to the first stitch in that color block.

Thread number is displayed for designs in .VP3 and .VIP-format. Thread manufacturer will be shown when using Quick help on a color block.

Example (A): 1:2, 2296 means the second thread color in the first loaded design is color number 2296.

Return to Embroidery edit

If you want to return to Embroidery edit, touch return to Embroidery edit icon on the option bar. When returning to Embroidery edit the embroidery arm will move to park position.

Note: It is very important that the hoop is removed before return to Embroidery edit, otherwise it may be damaged.

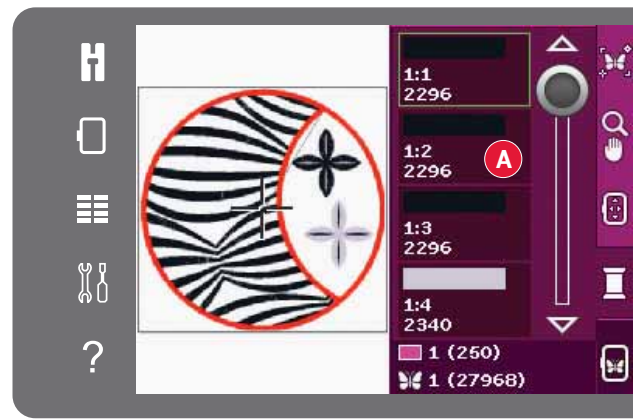
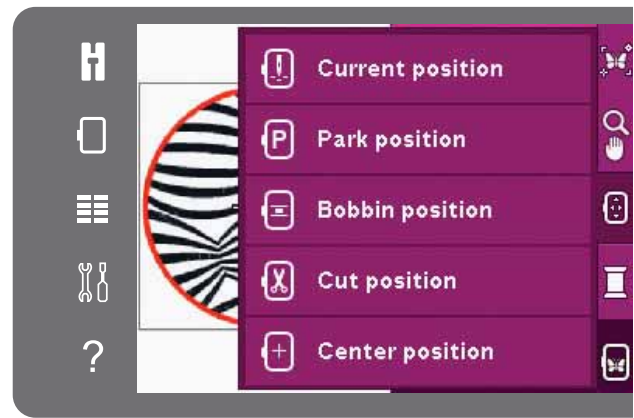

Return to
Embroidery edit

How to use basic precise positioning

To select locking point

The first step is to select a locking point (1). Place the green crosshair where you would like the locking point to be in your embroidery. The locking point is a point on the design on the screen that you want to match to a point on the fabric in the hoop. If you want to set the locking point in a corner, use the corner icons. Use zoom to crosshair to be able to place the crosshair exactly where you want it.

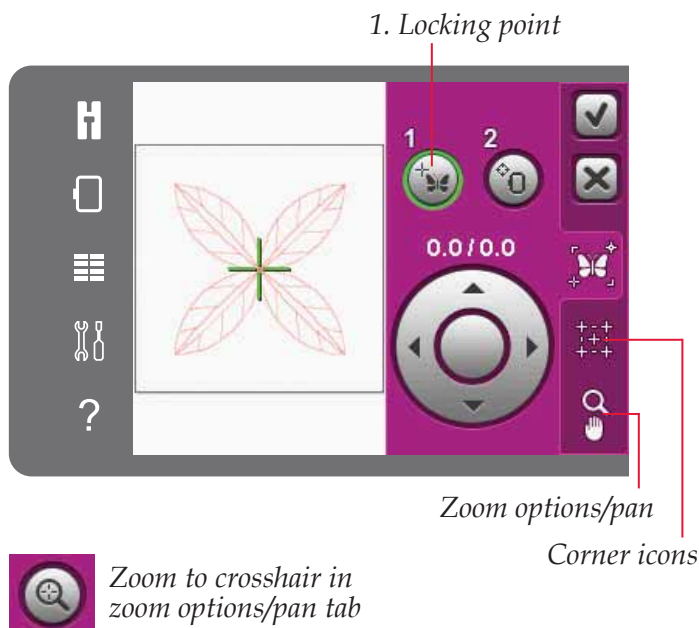

To select position hoop

Next step is to activate position hoop (2). The green crosshair will be locked on the screen, changing color from green to black with a ring around the center of the locking point. Now you can place the design exactly. Drag on the screen with the stylus or use the arrows on the wheel to move the hoop under the needle. Continue to move until the needle is exactly above the point on the fabric that you want to match. Check the position by lowering the needle with the hand wheel. Use the arrows of the wheel to fine tune if necessary.

The position of the needle indicates where the locking point is placed on the fabric.

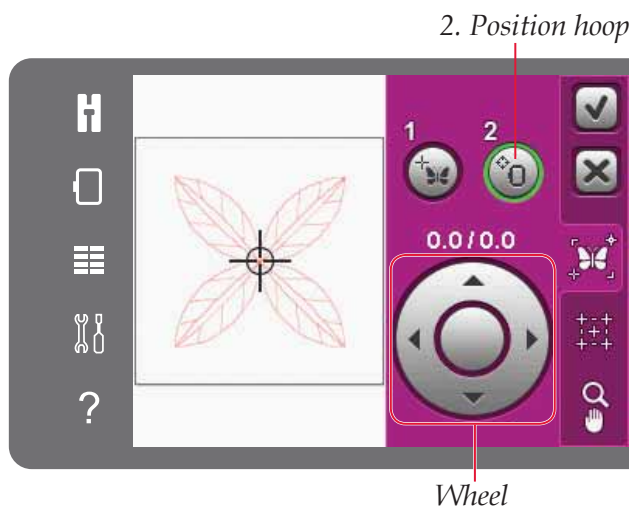

Disable needle warning

If trying to move the hoop with the needle lowered, a pop-up will appear. To allow lower needle position, touch in the box so that a checkmark appears. The needle can then remain close to the fabric when using basic precise positioning. Just make sure the needle is above the fabric to prevent damage to the needle and fabric.

Note: The warning cannot be disabled when the needle is below the needle plate.

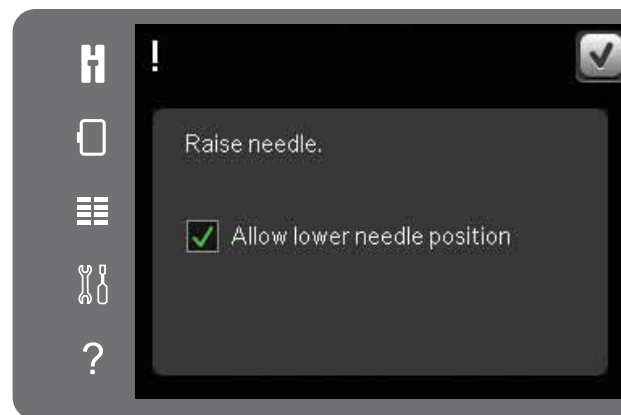

Corner icons

Use the corner icons to set the locking point in a corner of the design. This is the easiest and most precise way since the connecting point will be automatically placed exactly in the corner. This is useful when positioning a design on a patterned fabric.

The corner icons may also be used when locking point is selected. When touching one of the icons, the selected point will automatically be set to the corresponding position, i.e. at a corner or at the center of the embroidery.

E.g. when choosing the upper left corner icon, the connecting point will be set at the upper left corner in the outer line of the design(s). After this, you can continue and make your own adjustments on the connecting point.

Trace the design field

The corner icons can also be used to trace the design field by touching each of the four corner icons in turn. You can find the center of the design again by touching the centering icon.

Zoom to crosshair

Touch the zoom to crosshair icon to pan to the current crosshair position and zoom in as much as possible on the screen. You can position the locking and matching point exactly where you want them.

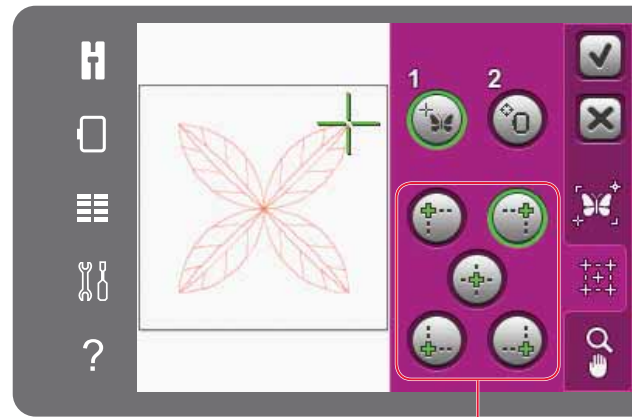

Corner icons

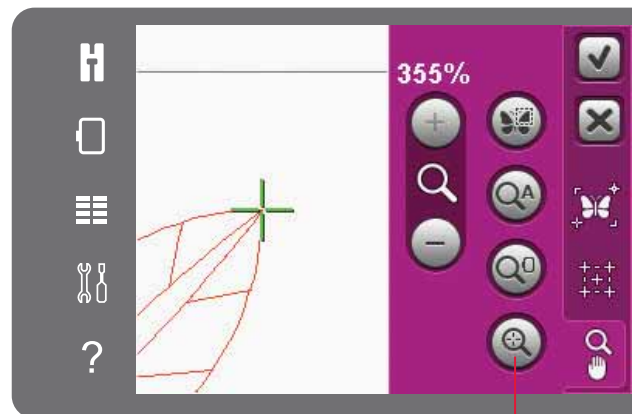

Zoom to crosshair

Common Embroidery stitch-out pop-ups

Embroidery unit calibration

When the embroidery unit is attached, a pop-up asks you to slide off the hoop and clear the machine area for calibrating the embroidery arm. You will also be reminded to disengage the IDT™ system and attach the correct embroidery presser foot.

Note: It is very important to remove the hoop, otherwise the hoop or the embroidery unit may be damaged while calibrating.

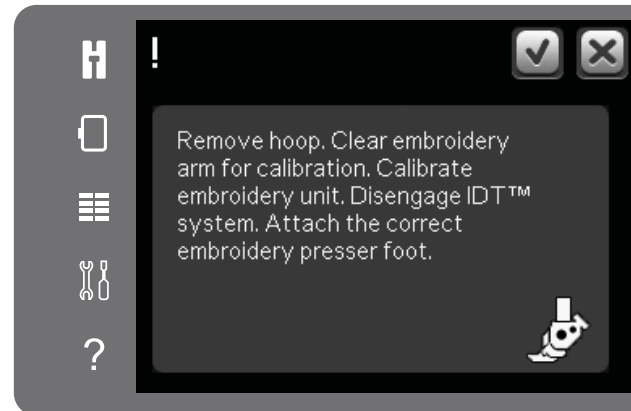

Attach correct hoop

If the size of the hoop attached to the machine does not match the size displayed on screen, the machine cannot embroider. You must change the hoop to the hoop size displayed in the pop-up or change the hoop setting.

To change hoop settings, return to Embroidery edit and touch select hoop icon.

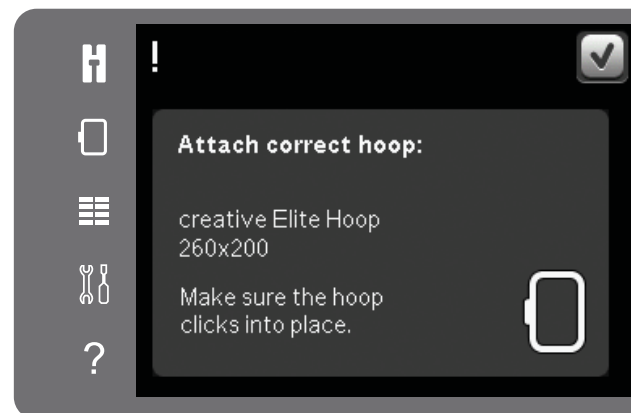

Bobbin thread low - move to bobbin position?

When the bobbin thread is running low, a pop-up message appears giving you an indication that the bobbin needs to be changed soon. This gives you an opportunity to plan where to stop embroidering and change the bobbin.

It is possible to embroider until the thread has completely run out. Press the start/stop button to continue embroidering without closing the bobbin thread low pop-up.

Touch cancel to remain at the current stitch position. Touch OK to move the hoop to bobbin position. The hoop position tab opens. Replace the empty bobbin with a full one. Touch Current position and pull back excess needle thread. Press start/stop or press your foot control to continue embroidering.



Check needle thread

The machine stops automatically if the needle thread runs out or breaks. Re-thread the needle thread, close the pop-up, step back a few stitches and start embroidering again.



Cut thread end

If cut jump stitches is not activated in machine settings in the settings menu, the machine will stop after stitching a few stitches. Cut the thread end and press start/stop to continue embroidering.



Change to Cutwork Needle (optional accessory)

Some cutwork designs can be stitched out using the optional accessory PFAFF® Embroidery Cutwork Needle Kit, (P/N 820 945-096). These designs are marked with a cutwork needle symbol in the creative™ 3.0 Embroidery Collection. When the machine stops and this pop-up message is shown, insert the corresponding cutwork needle. Touch OK and press the start/stop button to resume embroidering.

Note: These cutwork designs can also be stitched without the cutwork needles, but that color block will then have to be cut manually. If cutting manually, go to the next color block in the color block list when the pop-up appears.

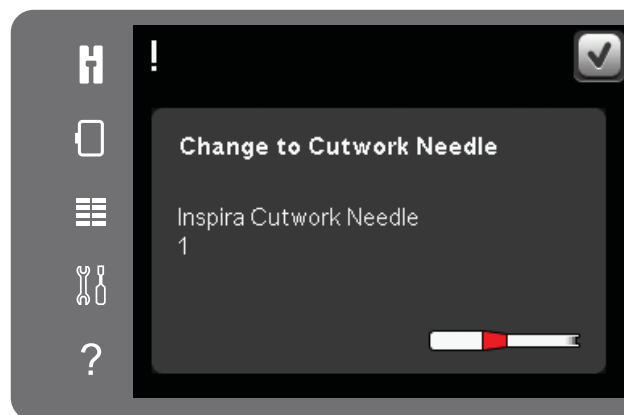

Machine needs to rest

If the machine stops and this pop-up appears on the screen, the machine needs to rest. When the OK icon is enabled you can resume embroidering. The embroidery results will not be affected.

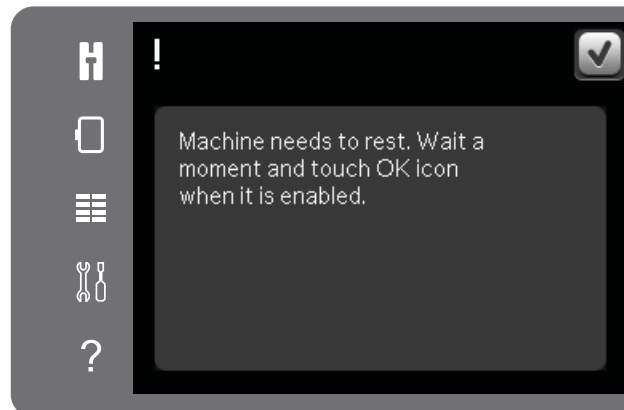



Personal files **10**

Personal files

Use personal files to organize, add, move, remove and copy all your designs and fonts. Use either built-in memory or an external device connected to your machine for storing.

Personal files - overview

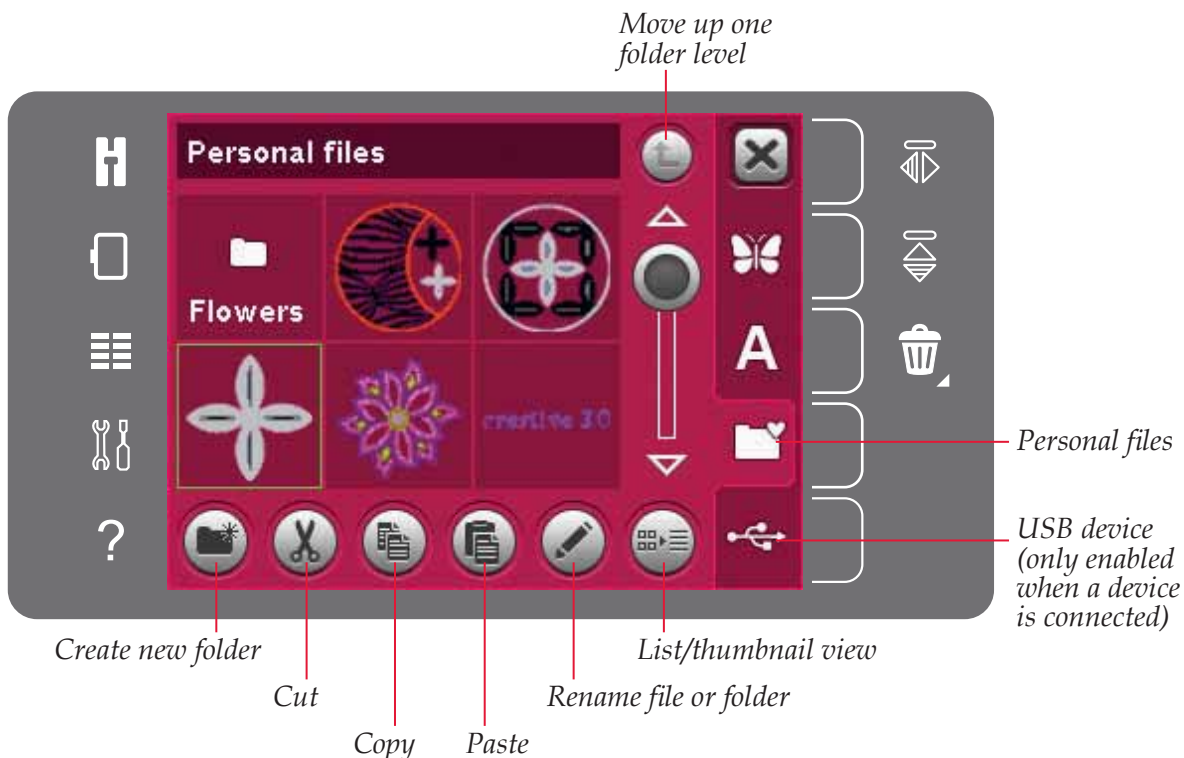

File formats

Your machine can load the following file formats:

- .SHV, .DHV, .VP3, .VIP, .HUS, .PEC, .PES, .PCS, .XXX, .SEW, .JEF, .EXP, .10* and .DST (embroidery files)
- .VF3 (embroidery font files)

Note: If the file type or file version is not supported by your machine, or the file is damaged, it is shown in the selection area as an unrecognized file.

Available memory

In the built-in memory you can store designs, fonts and other files. To check how much memory is left in the built-in memory, open the setting menu. Touch machine information in the selection bar to the right.

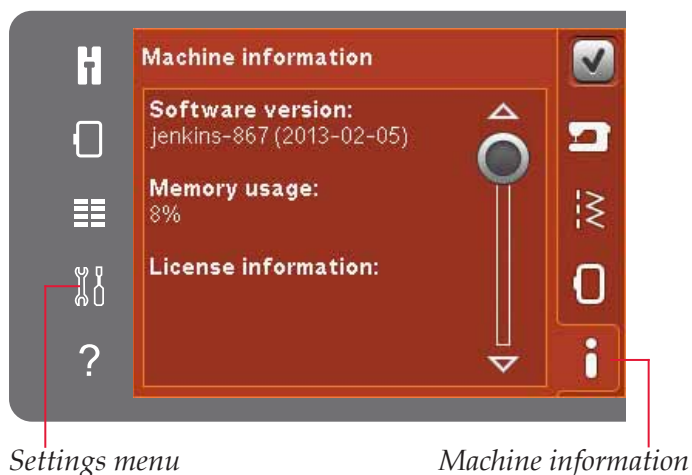

Browse personal files

To open personal files, first open selection menu. Select personal files in the selection bar at the right of the screen.

Fill personal files with designs, fonts and your customized designs.

Create folders and arrange your personal files so that you can find your favorites easily.

USB device

You can explore an USB device connected to the USB-port. The USB device icon is only enabled when a device is connected.

Touch the USB device to display the content in the selection area. Files are displayed as thumbnail images or with an icon.

List/thumbnail view

Touch the list/thumbnail view icon to show the files in a list with more space for the file name characters. For each file, file name and type will be displayed. Touch the list/thumbnail view icon again to toggle to thumbnail view.

Load a file

To load a file, long touch the desired file. Use the scroll bar to scroll down in the folder. You can only open one file at the time.

Open a folder

To open a folder in personal files, long touch the folder. The contents of the folder will be displayed on the screen.

Move up one folder level

Use the move up one folder level icon to step up through the levels of folders. You can step up all the way to the root level. On the screen you will see files and folders included in each level as you step.

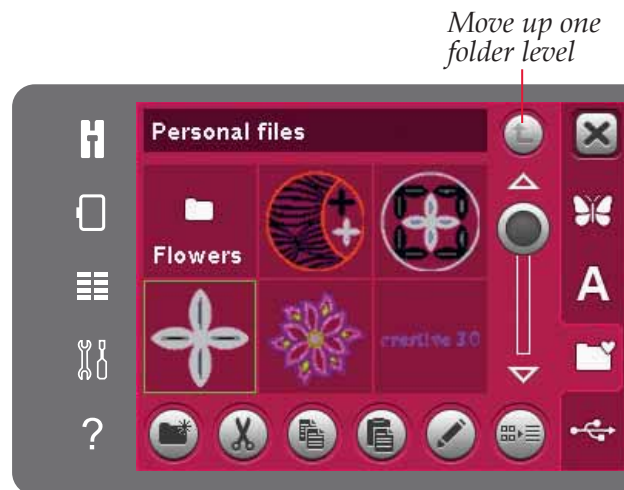
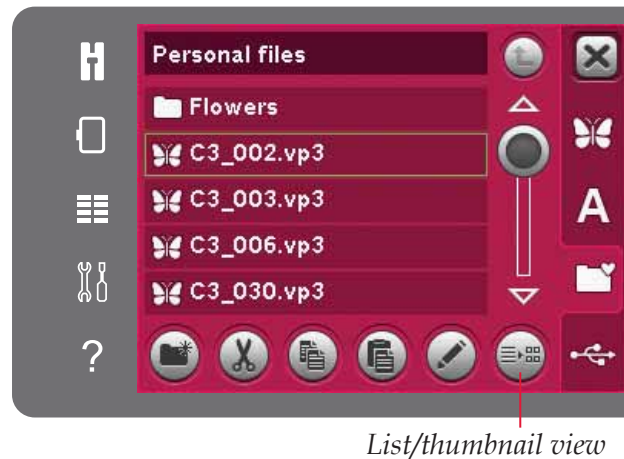
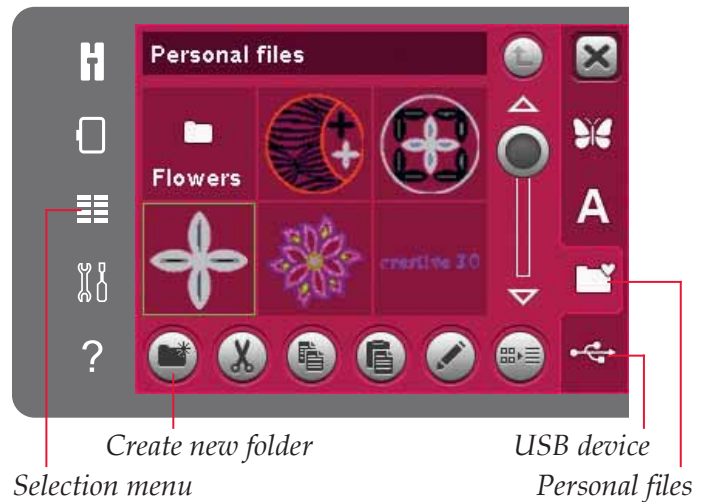

Organize

Create a new folder

Touch the create new folder icon to create a new folder. A pop-up opens to enter a name for your folder.

Move a file or folder

Use cut and paste to move a file or folder to another storage space. Select the file or folder, then touch cut. Open the folder where you want to place the file or folder. Touch paste.

Copy a file or folder

Use copy and paste to copy a file or folder to another storage space. Select the file or folder, then touch copy. Open the folder where you want to place the file or folder. Touch paste.

Delete a file or folder

To delete a file or folder, mark it and touch delete. A pop-up asks you to confirm the deletion. If a folder is deleted, all files within the folder are deleted as well.

To delete all files and folders in the current folder, long touch the delete icon.

Rename a file or folder

Select the folder or file you want to rename, then touch the rename icon to open a pop-up where you can change the name.

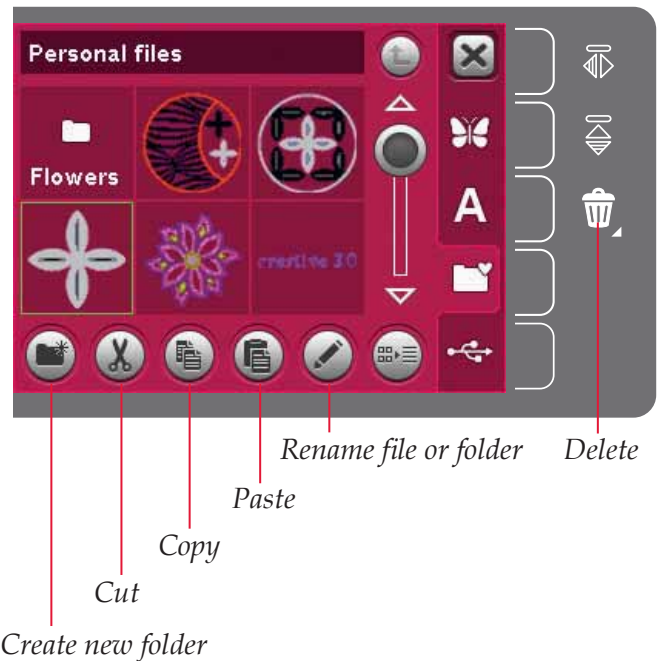

Common personal files pop-ups

Available memory is low

Your machine can store files in the built-in memory. When the memory is full, you can move them to an external device by using the cut and paste functions.

When only a small amount of memory is left, your machine will alert you once. If you continue to fill the memory, it will not remind you again, until the memory is completely full.

System busy

When the machine is loading, saving, moving files or anything that takes time, the system busy pop-up is shown.

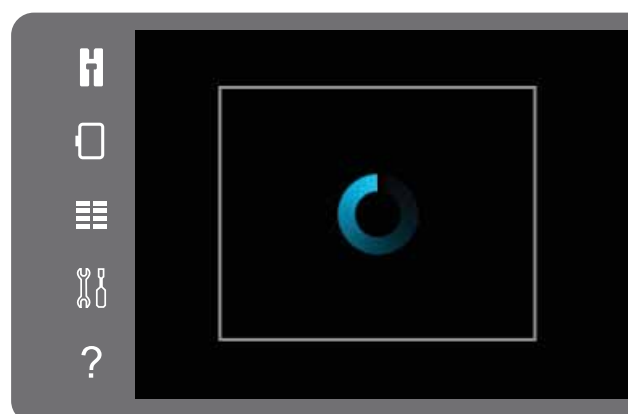
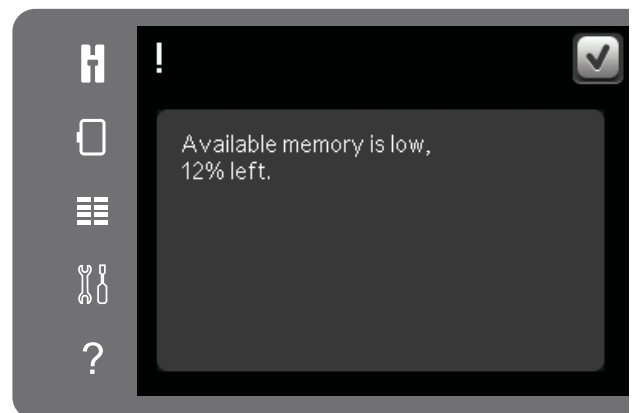



Maintenance 1 1

Cleaning the machine

To keep your sewing machine operating well, clean it often. No lubrication (oiling) is needed.

Wipe the exterior surface of your machine with a soft cloth to remove any dust or lint built up.

Note: Use of cleaners or solvents on the machine can cause damage to the plexifront.

Wipe the touch screen with the microfiber cloth included with your machine.

Cleaning the bobbin area

 *Note: Lower the feed dogs (see page 2:9) and turn off the machine.*

Remove the presser foot and slide off the bobbin cover. Place the screwdriver under the needle plate as shown in the picture and gently turn the screwdriver to pop off the needle plate. Clean the feed dogs with the brush found with the accessories.

Cleaning under the bobbin area

Clean the area under the bobbin case after sewing several projects or any time you notice an accumulation of lint in the bobbin case area.

Remove the bobbin case holder (A) covering the front part of the bobbin case by lifting it up. Remove the bobbin case (B) by lifting it up. Clean with the brush.

 *Note: Use caution when cleaning around the thread snips knife (C).*

Put the bobbin case and the bobbin case holder back in place.

Note: Do not blow air into the bobbin case area. The dust and lint will be blown into your machine.

Note: When using the optional accessory PFAFF® Embroidery Cutwork Needles, it is necessary to clean the bobbin area after each embroidered design/project.

Replacing the needle plate

With feed dogs lowered, place the needle plate with the knob fitting into the notch at the back (D). Press the needle plate down until it clicks into place. Slide on bobbin cover.

Non-original parts and accessories

The warranty does not cover any defect or damage caused by use of non-original accessories or parts.

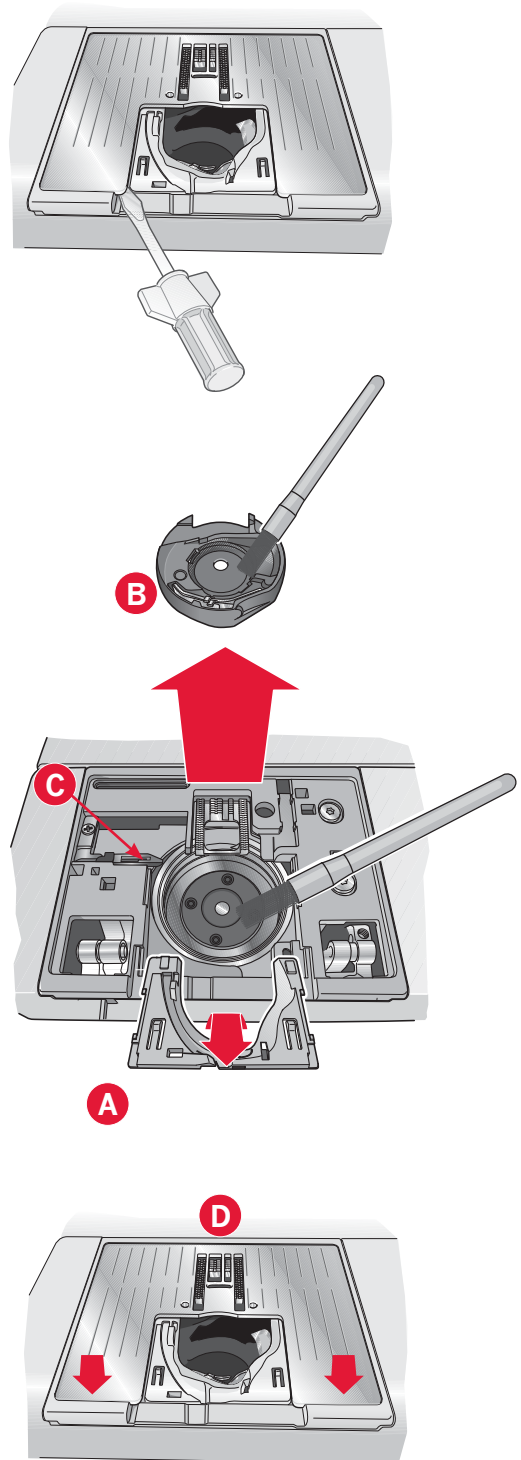

Troubleshooting

In this troubleshooting guide you will find solutions to the problems you may have with your machine. For further information please contact your local authorized PFAFF® dealer who will be happy to help you.

Problem/cause	Remedy
General problems	
Bobbin alarm does not work?	Clean lint from bobbin area and use only the original PFAFF® bobbins approved for this model.
Thread snip do not cut the thread?	Remove needle plate and clean lint from bobbin area. Enable automatic thread snip in the settings menu.
Fabric does not move?	Make sure that machine is not set in free-motion mode. See chapter 4. Make sure that the feed dogs are not lowered and that the embroidery unit is not attached.
Wrong stitch, irregular or narrow stitch?	Deactivate twin needle or stitch width safety in the settings menu.
The needle breaks?	Insert needle correctly as described in chapter 2. Attach correct needle for the fabric.
The machine will not sew?	Check that all plugs are securely plugged into the machine and into the wall socket. Check that the foot control cord is securely plugged into the foot control. Push bobbin winder lever to sewing position.
The PFAFF® creative™ Color Touch Screen displays the startup screen?	Touch the touch screen to activate. Turn off screen saver in the settings menu.
Icons on the touch screen are not activated when touched?	Close any pop-ups that may be blocking the screen. Calibrate the touch screen. Calibrate touch screen is found in the settings menu.
The sewing and embroidery machine screen and/or Function Buttons do not respond to touch?	The sockets and function buttons on the machine can be sensitive to static electricity. If the screen does not respond to touch, turn the machine OFF and then ON again. If the problem persists, contact your authorized PFAFF® dealer.

The machine skips stitches	
Did you insert the needle properly?	Change needle and insert correctly as described in chapter 2.
Did you insert a wrong needle?	Use needle system 130/705 H.
Is the needle bent or blunt?	Insert a new needle.
Did you thread the machine properly?	Check how the machine is threaded.
Is the correct presser foot used?	Attach correct presser foot.
Is the needle too small for the thread?	Change the needle.
Is the fabric moving up and down with the needle when free-motion sewing or embroidering?	Attach Dynamic spring foot 6D (optional accessory, part number 820991-096). If using foot 6A, reduce the presser foot height in embroidery settings. If sewing, reduce the presser foot height in free-motion options.

Needle thread breaks	
Did you insert the needle properly?	Change needle and insert correctly as described in chapter 2.
Did you insert a wrong needle?	Use needle system 130/705 H.
Is the needle bent or blunt?	Insert a new needle.
Did you thread the machine properly?	Check how the machine is threaded.

Is the needle too small for the thread?	Change the needle to the proper size for the thread.
Are you using poor thread with slubs or thread which has become dry?	Change to a new higher quality thread purchased from an authorized PFAFF® dealer.
Is a correct spool cap used?	Attach a spool cap of the right size for the actual thread spool as described in chapter 2.
Is the best spool pin position used?	Try a different spool pin position (vertical or horizontal).
Is the needle plate hole damaged?	Change the needle plate.

Bobbin thread breaks

Did you insert the bobbin properly?	Check the bobbin thread.
Is the needle plate hole damaged?	Change the needle plate.
Is the bobbin area full of lint?	Clean lint from bobbin area and use only the original PFAFF® bobbins approved for this model.
Is the bobbin wound correctly?	Wind a new bobbin as described in chapter 2.

The seam has uneven stitches

Is the thread tension correct?	Check needle thread tension and the threading.
Are you using too thick or slubbed thread?	Change the thread.
Is the bobbin thread evenly wound?	Check bobbin winding. See chapter 2.
Is a correct needle used?	Insert a proper needle correctly as described in chapter 2.

The machine does not feed or feeds irregularly

Did you thread the machine properly?	Check how the machine is threaded.
Has sewing lint collected between the feed dogs?	Remove the needle plate and clean the feed dogs with a brush.
Fabric does not move?	Make sure that the feed dogs are not lowered and that the embroidery unit is not attached.

Thread loops are forming on the underside of the embroidery design

Has the embroidery built up too much to move freely under the presser foot?	Increase the presser foot height in the settings menu in small steps until problem is solved.
---	---

The embroidery design is distorted

Is the fabric hooped properly?	The fabric must be tightly hooped.
Is the inner embroidery hoop completely inserted in the outer embroidery hoop?	Hoop the fabric in such a way that the inner hoop always exactly matches the outer hoop.
Is the area around the embroidery arm free?	Clear area around the embroidery unit and recalibrate.

The embroidery design has puckered

Did you stabilize your fabric sufficiently?	Ensure you use the proper stabilizer for your technique or fabric type.
---	---

The machine will not embroider

Is the embroidery unit attached?	Make sure that the embroidery unit is properly attached into the socket.
Is the wrong hoop attached?	Slide on the correct hoop.

System report

Is your machine displaying the system report pop-up?	When the system report pop-up appears, go to personal files/reports and locate the file (SystemReport01.dmp or higher number). Save the file to a USB stick. Send the file together with a short description of what you were doing before the pop-up appeared to product.improvement@pfaff.com . After sending the file, remove it from your machine.
--	---

INDEX

A

Accessories	1:9, 1:10
Accessory tray	1:9, 2:3, 7:3
Action indicator	1:8, 3:7
Add a stitch or stitch point	6:3
Add letter into a text	8:7
Adjust text and stitches	5:4
Adjust the entire sequence	5:5
All Purpose Sewing Thread	2:11
Alphabets	1:16
Antique hand embroidery stitches	1:15
Antique quilt stitches	1:15
Art stitches	1:16
Attach correct hoop	9:9
Attaching the Sensormatic buttonhole foot	4:15
Attach presser foot	2:9
Attach the embroidery foot 6A	7:2
Audio repeat	3:3
Automatic presser foot lift	3:4
Auxiliary spool pin	1:9
Available disk space low	10:4
Available memory	10:2

B

Balance	4:5
Basic precise positioning	9:2, 9:4, 9:7
Basting	9:2, 9:3
Blindhem foot with IDT™ system 3	1:11
Blindhem stitch	4:14
Elastic blindhem stitch	4:14
Bobbin area, cleaning	11:2
Bobbin cover	1:8
Bobbin, insert	2:8
Bobbin position	9:6
Bobbins	1:10
Bobbin thread guide	2:5
Bobbin thread low	4:21
Bobbin thread low - move to bobbin position?	9:9
Bobbin winder thread cutter	1:9
Bobbin winder thread guide	1:9
Bobbin winding	2:7
Bobbin winder thread guide	2:7
Winding from horizontal position	2:7
Winding while threaded	2:7
Browse personal files	10:3
Brush	1:10
Built-in designs	7:3
Built-in embroidery fonts	8:3
Built-in memory	10:2
Built-in needle threader	1:8, 2:5
Built-in USB port	1:8
Buttonhole	4:15

Attaching the Sensormatic buttonhole foot	4:15
Corded buttonhole	4:16
Manual buttonhole	4:16
Repeat a manual buttonhole	4:16
Sensormatic buttonhole	4:15
Button ruler	1:8
Buttons and indicators	3:6
Action indicator	3:7
Immediate tie-off	3:6
Needle up/down	3:6
Presser foot down and pivot toggle	3:6
Presser foot up and extra lift toggle	3:6
Reverse button	3:7
Reverse indicator	3:7
Speed control	3:6
Start/stop	3:7
Stitch restart	3:6
Thread snips	3:7
Button sewing	4:17

C

Calibrate touch screen	3:3
Cancel	3:8
Carrying case	1:10, 2:2
Category	4:3
Center position	9:6
Change to Cutwork Needle (optional accessory)	9:10
Changing the needle	2:9
Changing the presser foot	2:9
Attach presser foot	2:9
Remove presser foot	2:9
Character style	8:7
Check needle thread	4:21, 9:10
Cleaning the bobbin area	11:2
Cleaning the machine	11:2
Cleaning under the bobbin area	11:2
Color block list	7:6, 9:2, 9:4, 9:6
Color touch screen	1:8
Common icons	3:8
Cancel	3:8
Long touch	3:8
OK	3:8
OK and Cancel	3:8
Scroll bar	3:8
Complimentary software (PC)	2:12
Connecting the foot control cord	2:2
Connect the embroidery unit	7:3
Connect the foot control	2:2
Connect the power cord	2:2
Connect to and remove from USB port	2:12
Connect to the power supply	2:2
Copy	10:2, 10:4
Copy a file or folder	10:4
Corded buttonhole	4:16
Corner icons	9:4, 9:7, 9:8
Cover	2:3

Crazy patch stitches	1:15
Crazy quilt stitching	4:19
Create a new folder	10:4
Create a sequence	5:3
Create new folder	8:6, 10:2, 10:4
creative™ 3.0 Embroidery collection	7:3
creative™ 120 Square hoop	1:10
creative™ Elite hoop	1:10
Crosshair	9:2, 9:3, 9:7
Cross stitches	1:15
Current color block	9:4
Currently selected design	8:2
Current position	9:5
Current stitch in the current color block	9:2, 9:4
Current stitch in the design or combination	9:2, 9:4
Cut	10:2, 10:4
Cut-Away Stabilizer	2:11
Cut jump stitches	3:5
Cut position	9:6
Cut thread end	9:10

D

Darning	4:17
Decorative stitches	1:15
Definition of a stitch point	6:3
Delete	3:2, 8:5, 8:7, 10:4
Delete a design	8:5
Delete a file or folder	10:4
Delete a letter	8:7
Delete a sequence	5:5
Delete a stitch	4:7
Delete a stitch or letter	5:4
Delete selected stitch point	6:4
Delete symbol	4:7
Denim needle	2:10
Design adjustments	8:4
Delete	8:5
Load	8:3
Mirroring	8:5
Move	8:4
Move design into hoop	8:5
Rotate	8:4
Scale	8:4
Design field, trace	9:8
Design file	10:2
Design, load	8:3
Designs	8:3
Designs, built-in	7:3
Disable needle warning	9:7
Disengaging the IDT™ system	2:8
Disintegrating Stabilizer	2:11
Duplicate	6:2, 6:4
Duplicate selected stitch point	6:4
Dynamic spring foot 6D	3:5, 4:8
Dynamic spring foot 6D free-motion	4:8

E

Edge guide	1:10
Elastic blindhem stitch	4:14
Embroidery arm	1:9, 7:2
Embroidery bobbin thread	2:11
Embroidery collection	1:10, 7:3
Embroidery edit	8:2–8:8
Embroidery edit pop-ups	8:8
Embroidery font file	10:2
Embroidery fonts, built-in	8:3
Embroidery foot 6A	1:11, 7:2
Embroidery hoop connection assembly	1:9, 7:2
Embroidery hoop overview	7:2
Embroidery information	9:4
Embroidery mode	3:2, 7:5, 8:2
Embroidery needle	2:10
Embroidery settings	3:5
Embroidery stitch-out	7:5, 8:2, 8:6, 8:7, 9:2–9:10
Embroidery stitch-out pop-ups	9:9
Embroidery text editor	8:2, 8:6, 8:7
Embroidery thread	2:11
Embroidery unit	1:9
Overview	7:2
Embroidery unit calibration	9:9
Embroidery unit, connect	7:3
Embroidery unit connection socket	1:9, 7:2
Embroidery unit overview	1:9, 7:2
Embroidery unit release button	1:9, 7:2
Embroidery unit, remove	7:3
Engaging the IDT™ system	2:8
Exit sequencing	5:3
Exit Stitch Creator	6:3

F

Fancy stitch foot 2A	1:11
Fancy stitch foot with IDT™ system 1A	1:11
Feeding length from previous stitch point	6:2, 6:5
Felt pad	1:10, 2:4
File, load	10:3
File formats	10:2
File or folder	10:4
Copy	10:4
Create	10:4
Delete	10:4
Rename	10:4
Floral and ornamental stitches	1:16
Folder, open	10:3
Folder level	10:3
Font, load	8:3
Font style	5:3
Foot control	1:10
Free arm	1:8, 2:3
Free-motion options	4:2, 4:8
Free-motion stippling	4:20
Fun stitches	1:16

G

Getting started embroidering.....	7:5
Grid	6:2

H

Handle	1:9
Handlook quilting.....	4:19
Handlook quilt stitches	1:16
Handlook stitches.....	1:15
Handwheel.....	1:8
Hard cover	2:3
Hems in heavy fabric.....	4:13
Hemstitches.....	1:15
Hoop clips	1:10
Hoop position.....	9:2, 9:4, 9:5
Hoop selection.....	8:7
Hoop, slide on/off	7:4
Hoop the fabric.....	7:4
How to use basic precise positioning.....	9:7

I

Icons, common.....	3:8
Cancel	3:8
Long touch	3:8
OK	3:8
Scroll arrows.....	3:8
IDT™ system.....	1:9, 2:8, 4:8, 4:14, 4:15, 4:19, 7:5
Disengaging.....	2:8
Engaging	2:8
IDT™ system/Lower feed dogs recommended.....	4:2
Immediate tie-off.....	1:8, 3:6
Important sequencing information	5:6
Included accessories	1:10
Included hoops.....	1:10
Insert a new stitch point.....	6:4
Inserting the bobbin.....	2:8
Intellectual Property	11:11
Iron-on tear-away.....	2:11

L

Language	3:3
LED lights.....	1:8, 2:3
License information	3:5, 10:2
Lid	1:8
List/thumbnaill view	10:2, 10:3
Load a design.....	8:3
Load a file.....	10:3
Load a font	8:3
Load a sequence	5:5
Load from personal files/USB device.....	8:3
Loading and sewing a sequence	5:5

Locking point.....	9:4, 9:7
Lock screen.....	3:3
Long touch	3:8
Lower feed dogs.....	2:9
Lower feed dogs recommendation.....	4:8

M

Machine information	3:5
Machine needs to rest.....	4:21, 9:10
Machine overview.....	1:8
Machine settings.....	3:3
Main switch.....	1:8
Maintenance.....	11:2
Manual buttonhole.....	4:16
Manual buttonhole foot 5M.....	1:11
Marked stitch point.....	6:3
Memory available	10:2
Microfiber cloth	11:2
Mirror a design.....	8:5
Mirror end to end.....	3:2, 4:6, 6:4, 8:5
Mirroring.....	4:6, 8:5
Mirror side to side.....	3:2, 4:6, 6:4, 8:5
Monochrome.....	9:2, 9:3, 9:4
Move	6:2, 6:5, 8:4
Move a file or folder.....	10:4
Move design into hoop.....	8:2, 8:5
Move up one folder level	10:2, 10:3
Multi-purpose tool.....	1:10, 2:9, 4:17

N

Needle art stitches.....	1:15
Needle bar	1:8
Needle plate	1:8
Needles	1:10, 2:10
Denim needle.....	2:10
Embroidery needle	2:10
Stretch needle	2:10
Universal needle	2:10
Wing needle.....	2:10
Needle screw.....	1:8
Needle threader.....	1:8, 2:5
Needle thread guide	1:8, 2:5
Needle up/down	1:8, 3:6
New folder	10:4
New stitch point.....	6:2, 6:3
Non-original parts and accessories	11:2

O

OK	3:8, 8:6, 8:7
Open a folder	10:3
Open sequencing.....	5:3
Open Stitch Creator	6:3

Optional accessories	2:5, 4:8, 4:17, 4:19, 4:20, 9:10, 11:2
Optional feet stitches	1:16
Optional presser foot	4:20, 7:2
Option bar	8:6, 9:4
Organize	10:4
Original size	8:4
Overview	
Embroidery edit	8:2
Embroidery hoop	7:2
Embroidery stitch-out	9:2
Embroidery unit	7:2
Machine	1:8
Personal files	10:2
Sequencing	5:2
Sewing mode	4:2
Stitch Creator	6:2
Stitches	1:12

P

Pack away after sewing	2:3
Padlock	8:4
Park position	7:3, 9:5
Parts of the embroidery unit	1:9
Paste	10:2, 10:4
Patchwork program	4:12, 4:18
Personal files	4:3, 7:5, 8:3, 10:2-10:4
Personal files, save	8:6
PFAFF® creative™ Color Touch Screen	1:8
Piecing the quilt top	4:18
Pop-up messages	
Attach correct hoop	9:9
Available disk space low	10:4
Bobbin thread low	4:21
Bobbin thread low - move to bobbin position?	9:9
Change to Cutwork Needle (optional accessory)	9:10
Check needle thread	4:21, 9:10
Cut thread end	7:6, 9:10
Disable needle warning	9:7
Embroidery combination is too complex	8:8
Embroidery is finished	7:6
Embroidery unit calibration	9:9
Exceeded maximum number of stitches	8:8
Machine needs to rest	4:21, 9:10
Not an editable stitch	5:6, 6:6
Remove hoop	8:8
Remove Sensormatic buttonhole foot	4:21
Sequence out of range	5:6, 6:6
System busy	10:4
Use thread color	7:5
Position hoop	9:4, 9:7
Position of the marked stitch point	6:5
Power cord	1:10
Presser feet, included	1:11
Presser foot	1:8
Presser foot bar	1:8
Presser foot, change	2:9

Presser foot down and pivot toggle	1:8, 3:6
Presser foot height	3:5
Presser foot height control	3:5
Presser foot holder	1:8
Presser foot pressure	3:4
Presser foot pressure control	3:4
Presser foot recommendation	4:2
Presser foot up and extra lift toggle	1:8, 3:6
Pre-tension device for threading and bobbin winding	1:9
Pre-tension disc	2:5

Q

Quick help	3:2, 4:8, 4:20
Quilting	4:18
Crazy quilt stitching	4:19
Patchwork program	4:18
Piecing the quilt top	4:18
Straight stitch needle plate	4:18
Quilt stitches	1:15

R

Removable bobbin holder	1:9
Removable tray for presser feet	1:9
Remove presser foot	2:9
Remove Sensormatic buttonhole foot	4:21
Remove the embroidery unit	7:3
Rename	8:6
Rename a file or folder	10:2, 10:4
Repeat a manual buttonhole	4:16
Replace a stitch or letter	5:4
Replacing the needle plate	11:2
Return to Embroidery edit	9:2, 9:4, 9:6
Reverse	1:8
Reverse button	3:7, 4:10, 4:11, 4:12
Reverse indicator	1:8, 3:7
Rotate	8:4

S

Satin and edge stitches	1:15
Save to personal files	8:2, 8:6
Save to personal menu	4:2, 4:7, 5:5
Saving a sequence	5:5
Saving a stitch	4:7, 6:6
Scale	8:4
Screen	1:8
Screen, lock	3:3
Screen saver	3:3
Screwdriver	1:10
Scroll bar	3:8
Seam ripper	1:10
Select a font	4:3
Select a stitch	4:3

Select design.....	8:2, 8:5
Selected stitch number	4:2
Select hoop	8:2, 8:6, 8:7
Selection menu.....	3:2, 4:3, 7:5, 8:3, 10:3
Select stitches/stitch points	6:3
Sensormatic buttonhole.....	4:15
Sensormatic buttonhole foot 5A.....	1:11, 4:15
Sensormatic buttonhole foot socket.....	1:8
Sensormatic free-motion	4:9
Sensormatic free-motion foot 6A	1:11, 4:9, 7:2
Sequence adjustments	5:5, 5:6
Sequence commands	5:4
Sequences in Stitch Creator	5:6
Sequencing	
Adjust text and stitches.....	5:4
Adjust the entire sequence	5:4
Create sequence from letters.....	5:3
Create sequence from stitches.....	5:3
Delete a sequence.....	5:5
Delete a stitch or letter	5:4
Insert a stitch or letter.....	5:4
Replace a stitch or letter	5:4
Sequencing pop-ups	5:6
Settings menu	3:2, 3:3
Sew a sequence.....	5:5
Sewing a stitch.....	6:6
Sewing hems in heavy fabric.....	4:13
Sewing in zippers.....	4:13
Sewing mode	3:2, 4:2–4:22
Sewing options	4:2
Sewing pop-ups.....	4:21
Sewing programs	4:11
Patchwork program.....	4:12
Single stitch program	4:11
Tapering program.....	4:11
Sewing settings.....	3:4
Sewing techniques	1:16, 4:13
Sewing thread.....	2:11
Sew on a button	4:17
Shipping brace.....	7:2
Single stitch program.....	4:11
Slide for lowering the feed dogs	1:8
Slide on/off the hoop	7:4
Slit length.....	4:15
Smocking stitches.....	1:15
Software (PC).....	2:12
Software version.....	3:5, 10:2
Special sewing techniques	4:20
Speed control	1:8, 3:6, 4:6, 9:2
Speed control symbol	4:2, 9:2
Spool cap	1:9, 1:10, 2:4
Spool pin.....	1:9
Spool pins	2:4
Auxiliary spool pin.....	2:4
Horizontal position.....	2:4
Main spool pin	2:4
Vertical position	2:4
Spring foot free-motion.....	4:8
Stabilizer recommended	4:2
Stabilizers	2:11
Standard presser foot with IDT™ system 0A	1:11
Start/stop	1:8, 3:6, 3:7
Start view.....	4:2
Step stitch by stitch	9:2, 9:3
Sticky Stabilizer	2:11
Stippling stitches	1:15
Stitch category	4:3
Stitch Creator™ feature.....	4:12, 6:2–6:6
Load a stitch.....	6:6
Save a stitch	6:6
Sew a stitch	6:6
Stitch Creator™ feature pop-ups.....	6:6
Stitch density	4:5, 5:2, 5:4
Stitches	4:3
Stitch fonts.....	4:3
Stitch-in-the-Ditch.....	4:19
Stitch length	4:2, 4:4, 4:5, 5:2, 5:4
Stitch overview	1:12
Stitch point	6:3
Stitch point side position.....	6:2, 6:5
Stitch positioning	4:4, 5:2, 5:4
Stitch repetition	4:17
Stitch restart	1:8, 3:6
Stitch, select.....	4:3
Stitch settings.....	4:4
Balance.....	4:5
Mirroring.....	4:6
Stitch density	4:5
Stitch length.....	4:5
Stitch positioning	4:4
Stitch width.....	4:4
Thread tension.....	4:6
Stitch width	4:2, 4:4, 5:2, 5:4
Stitch width safety.....	3:4, 4:8
Stop command.....	5:2, 5:4
Straight stitch needle plate (optional)	4:18
Stretch needle.....	2:10
Stylus.....	1:10
Stylus holder	1:8
Subcategory.....	4:3
System busy	10:4
 T	
Take-up lever	1:9, 2:5
Tapering program	4:11
Tear-away Stabilizers	2:11
Thread cutter.....	1:8, 2:3
Thread guide.....	1:9
Threading for twin needle	2:6
Threading the machine.....	2:5
Needle threader	2:5

Thread manufacturer.....	9:6
Thread net	1:10
Threads	2:11
Thread sensor	2:6
Thread snips.....	1:8, 3:7, 4:10
Thread snips command.....	5:2, 5:4
Thread snips for embroidery.....	3:5
Thread snips for sewing.....	3:4
Thread tension.....	4:2, 4:6, 9:2, 9:3
Thread tension disk	1:9
Three-step zigzag stitch.....	4:14
Tie-off beginning.....	4:10
Tie-off command.....	5:2, 5:4
Tie-off end	4:10
Tie-off options.....	4:2, 4:10
To select locking point.....	9:7
To select position hoop.....	9:7
Total number of designs	8:2
Total number of stitches.....	8:2
Touch function - Move	6:2, 8:2, 8:4
Touch function - Rotate.....	8:2, 8:4
Touch function - Scale	8:2, 8:4
Touch function - Zoom/Pan	6:2
Touch screen	3:2
Trace the design field.....	9:8
Transparent thread	2:11
Triple stitch	6:2, 6:4
Troubleshooting	11:3
Twin needle.....	2:6, 3:4, 4:2
Twin needle/stitch width safety.....	4:2
Twin needle width.....	3:4

Z

Zipper foot with IDT™ system 4	1:11
Zippers, sewing	4:13
Zoom in	8:6, 9:5
Zoom options/pan.....	8:2, 8:6, 9:2, 9:4, 9:5, 9:7
Zoom out	8:6, 9:5
Zoom/Pan.....	6:2, 6:5
Zoom to all	8:6, 9:5
Zoom to box.....	8:6, 9:5
Zoom to crosshair	9:7, 9:8
Zoom to hoop	8:6, 9:5

U

Universal needle.....	2:10
Unpacking.....	2:2
Unrecognized file	10:2
Update your machine.....	2:13
USB device	4:3, 7:5, 8:3, 10:2, 10:3
USB embroidery stick.....	1:10, 2:12
USB port	1:8, 2:12
Connect to and remove from USB port.....	2:12
Using the USB embroidery stick.....	2:12
Utility stitches.....	1:12

W

Water Soluble Stabilizer	2:11
Wheel	6:2, 8:2, 9:4
Wheel center	8:2, 8:4
Wheel control.....	9:4
Winding from horizontal position.....	2:7
Winding while threaded.....	2:7
Wing needle	2:10



www.pfaff.com