

PFAFF

Perfection starts here.™



passport™ line

Owner's manual

This household sewing machine is designed to comply with IEC/EN 60335-2-28 and UL1594.

IMPORTANT SAFETY INSTRUCTIONS

When using an electrical appliance, basic safety precautions should always be followed, including the following:

Read all instructions before using this household sewing machine. Keep the instructions at a suitable place close to the machine. Make sure to hand them over if the machine is given to a third party.

DANGER – To reduce the risk of electric shock:

- A sewing machine should never be left unattended when plugged in. Always unplug this sewing machine from the electric outlet immediately after using and before cleaning, removing covers, lubricating or when making any other user servicing adjustments mentioned in the instruction manual.

WARNING – To reduce the risk of burns, fire, electric shock, or injury to person:

- Do not allow to be used as a toy. Close attention is necessary when this sewing machine is used by or near children.
- Use this sewing machine only for its intended use as described in this manual. Use only attachments recommended by the manufacturer as contained in this manual.
- Never operate this sewing machine if it has a damaged cord or plug, if it is not working properly, if it has been dropped or damaged, or dropped into water. Return the sewing machine to the nearest authorized dealer or service center for examination, repair, electrical or mechanical adjustment.
- Never operate the sewing machine with any air openings blocked. Keep ventilation openings of the sewing machine and foot control free from the accumulation of lint, dust, and loose cloth.
- Keep fingers away from all moving parts. Special care is required around the sewing machine needle.
- Always use the proper needle plate. The wrong plate can cause the needle to break.
- Do not use bent needles.
- Do not pull or push fabric while stitching. It may deflect the needle causing it to break.
- Wear safety glasses.
- Switch the sewing machine off ("0") when making any adjustment in the needle area, such as threading needle, changing needle, threading bobbin, or changing presser foot, etc.
- Never drop or insert any object into any opening.
- Do not use outdoors.
- Do not operate where aerosol (spray) products are being used or where oxygen is being administered.
- To disconnect, turn all controls to the off ("0") position, then remove plug from outlet.
- Do not unplug by pulling on cord. To unplug, grasp the plug, not the cord.
- The foot control is used to operate the machine. Avoid placing other objects on the foot control.
- Do not use the machine if it is wet.
- If the LED lamp is damaged or broken, it must be replaced by the manufacturer or its service agent or a similarly qualified person, in order to avoid a hazard.
- If the supply cord connected with the foot control is damaged, it must be replaced by the manufacturer or its service agent or a similarly qualified person, in order to avoid a hazard.
- This sewing machine is provided with double insulation. Use only identical replacement parts. See instructions for Servicing of Double-Insulated Appliances.

SAVE THESE INSTRUCTIONS

For Europe only:

This appliance can be used by children aged from 8 years and above and persons with reduced physical, sensory or mental capabilities or lack of experience and knowledge if they have been given supervision or instruction concerning use of the appliance in a safe way and understand the hazards involved. Children shall not play with the appliance. Cleaning and user maintenance shall not be made by children without supervision.

The noise level under normal operating conditions is less than 75dB(A).

The machine must only be used with foot control of type "C-9002" manufactured by CHIENHUNG TAIWAN., LTD.

For outside Europe:

This sewing machine is not intended for use by persons (including children) with reduced physical, sensory or mental capabilities, or lack of experience and knowledge, unless they have been given supervision or instruction concerning use of the sewing machine by a person responsible for their safety. Children should be supervised to ensure that they do not play with the sewing machine.

The noise level under normal operating conditions is less than 75dB(A).

The machine must only be used with foot control of type "C-9002" manufactured by CHIENHUNG TAIWAN., LTD.

SERVICING OF DOUBLE INSULATED PRODUCTS

In a double-insulated product, two systems of insulation are provided instead of grounding. No ground means is provided on a double-insulated product, nor should a means for grounding be added to the product. Servicing of a double-insulated product requires extreme care and knowledge of the system and should be done only by qualified service personnel. Replacement parts for a double-insulated product must be identical to those parts in the product. A double-insulated product is marked with the words 'DOUBLE INSULATION' or 'DOUBLE INSULATED'.



Congratulations!

Congratulations on purchasing your new PFAFF® sewing machine. As a sewing enthusiast, you have acquired a machine that features the very latest in both design and technology, enabling you to transform your creative ideas into reality.

Before you start, please spend some time reading this owner's manual. You will soon discover how to maximize the use of your machine. Our authorized PFAFF® dealer will of course also be pleased to advise you as well.

Your PFAFF® passport™ sewing machine will definitely enable you to experience a totally new dimension of sewing!

Table of contents

Introduction	4	Sewing	21
Machine overview	4	Select a stitch.....	21
Accessories.....	5	Stitch adjustments.....	21
Presser feet.....	6	Sewing techniques.....	22
Stitch overview.....	7	Three-step zigzag stitch.....	22
Preparations	9	Buttonholes.....	22
Unpacking.....	9	Sew on a button	23
Connect to the power supply	9	Darning and mending	24
Pack away after sewing.....	9	Sewing hems in heavy fabric	24
Free arm.....	10	Quilting.....	25
Leveling the machine base plate	10	Blindhem.....	26
Thread cutter.....	10	Sewing in zippers	26
Spool pins.....	10	Maintenance	27
Threading the machine.....	11	Cleaning the machine.....	27
Needle threader	12	Replacing the stitch plate	27
Threading for twin needle.....	12	Troubleshooting.....	28
Bobbin winding.....	13		
Inserting the bobbin.....	14	Intellectual property	29
IDT™ system (integrated dual feed).....	14		
Presser foot pressure.....	15		
Thread tension.....	15		
Needles	16		
Changing the needle	17		
Lowering feed dogs.....	17		
Presser foot lift	17		
Changing the presser foot	17		
Buttons.....	18-19		
Warning messages/sound	20		

Note: The machine models will be referred to as simply 3.0 and 2.0 in this manual.

Introduction

Machine overview

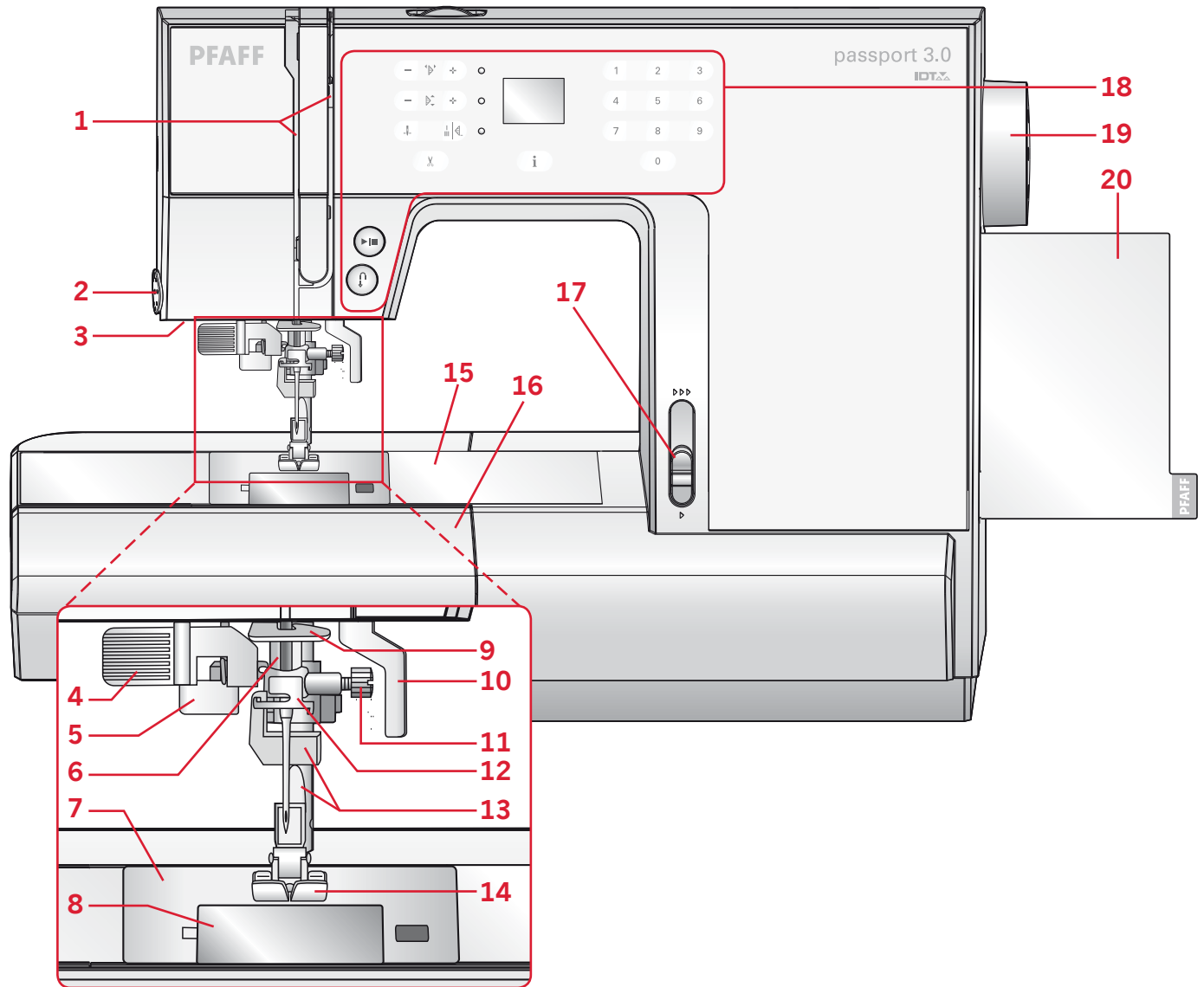

Front side

- | | |
|-----------------------------|--|
| 1. Threading slots | 11. Needle screw |
| 2. Thread cutter | 12. Needle thread guide |
| 3. LED lights | 13. Presser foot bar and presser foot holder |
| 4. Built-in needle threader | 14. Presser foot |
| 5. Buttonhole lever | 15. Free arm |
| 6. Needle bar | 16. Accessory tray |
| 7. Stitch plate | 17. Speed control lever |
| 8. Bobbin cover | 18. Buttons and LED display |
| 9. Lower thread guide | 19. Handwheel |
| 10. Presser foot lift | 20. Pull-out stitch overview |

Top parts

21. Presser foot pressure dial
22. Thread guides
23. Spool caps
24. Hole for auxiliary spool pin
25. Bobbin winder lever and bobbin spindle
26. Take-up lever
27. Thread tension discs
28. Bobbin winder tension disc
29. Thread tension dial

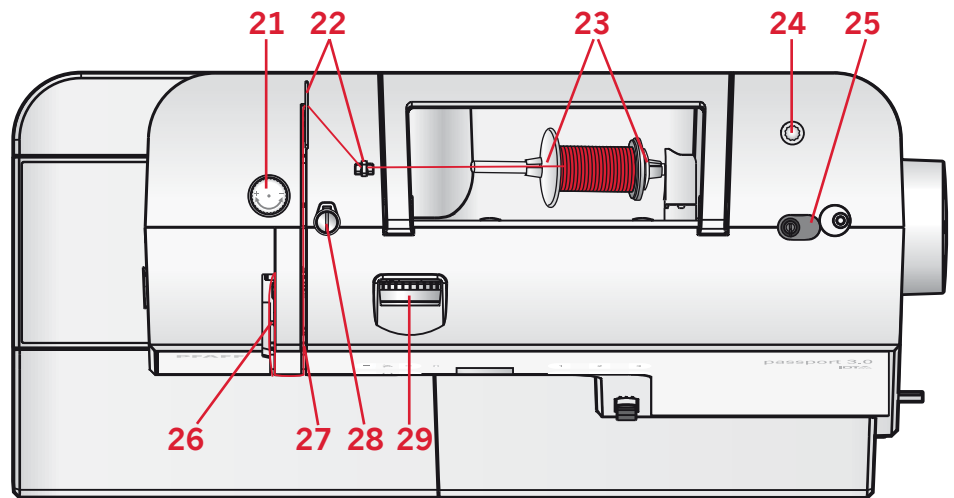

Rear side

30. Main switch, connectors for power cord and foot control
31. Handle
32. Presser foot lift
33. IDT™ system
34. Slide for lowering the feed dogs

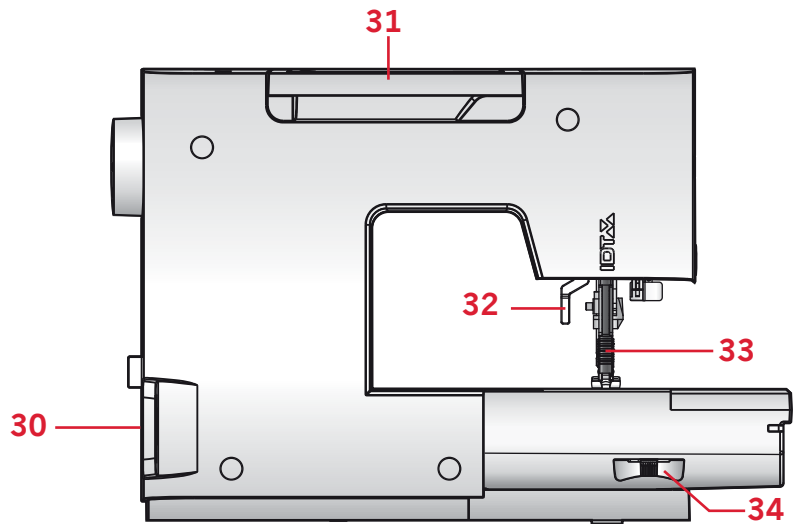

Accessories

Included accessories



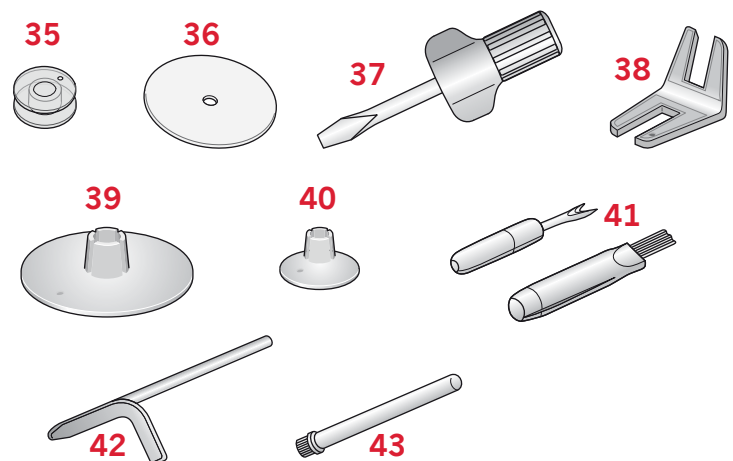

35. Bobbins (5) (#416475801)
36. Felt pad
37. Screwdriver for needle plate
38. Multi-purpose tool
39. Spool cap, large (2)
40. Spool cap, small
41. Seam ripper & brush (as one)
42. Edge guide
43. Auxiliary spool pin



Included accessories not in picture

- Foot control
- Power cord
- Needles
- Hard cover

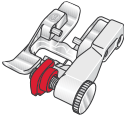
Presser feet

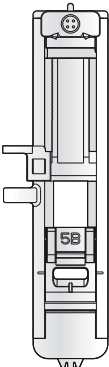





















	<p>Standard presser foot 0A with IDT™ system (shown as 0A in the display, attached on the machine upon delivery)</p> <p>This foot is used mainly for straight stitching and zigzag stitching with a stitch length longer than 1.0 mm.</p>
	<p>Fancy stitch foot 1A with IDT™ system (shown as 1A in the display)</p> <p>This foot is used for decorative stitches. The groove on the underside of the foot is designed to flow smoothly over the stitches.</p>
	<p>Fancy stitch foot 2A (shown as 2A in the display)</p> <p>When sewing decorative stitches or short zigzag stitches and other utility stitches with less than 1.0 mm stitch length, use this foot. The groove on the underside of the foot is designed to flow smoothly over the stitches.</p>
	<p>Blindhem foot 3 with IDT™ system (shown as 3 in the display)</p> <p>This foot is used for blindhem stitches. The toe on the foot guides the fabric. The red guide on the foot is designed to ride along the fold of the hem edge.</p>
	<p>Zipper foot 4 with IDT™ system</p> <p>This foot can be snapped on either the right or the left of the needle, making it easy to sew close to both sides of the zipper teeth. Move the needle position to the right or left to sew closer to zipper teeth.</p>
	<p>One step Buttonhole foot 5B (shown as 5B in the display)</p> <p>This foot has a space in the back to set the size of the buttonhole. The machine will sew a buttonhole to fit that button size.</p>

Important: Make sure that the IDT™ system is disengaged when using presser foot 2A, 5B.

Stitch overview

Utility stitches

● = Engage IDT™ system

Stitch	3.0	2.0	Name	Description
	00	01	Straight stitch	For seaming and topstitching. Select from 29 different needle positions.
	01	02	Stretch triple straight stitch	Reinforced seam. Topstitching.
	02	03	Zigzag stitch	Reinforce seams, clean finish, stretch sewing, lace insertion.
	03	04	Z-zigzag stitch	Appliqué, couching, eyelets.
	04	05	Stretch triple zigzag stitch	Elastic stitch for decorative hems or topstitching.
	05	06	Three-step zigzag stitch	Sewing elastic, darning, patching.
	06	07	Honeycomb stitch	Decorative stitch for stretch fabrics and hems. Also used with elastic thread in the bobbin.
	07	-	Bridging stitch	Joining fabrics and quilt batting, decorative stitch for quilting, hemstitching.
	08	-	Foundation elastic stitch	Joining stitch for undergarments, terry cloth, leather, bulky fabrics where overlapping the seams.
	09	08	Crosshem stitch	Elastic decorative hem for stretch fabrics.
	10	09	Blindhem stitch	Sewing blindhems on woven fabrics.
	11	10	Elastic blindhem stitch	Sewing blindhems on stretch fabrics.
	12	11	Stretch tricot stitch	Sewing seams on stretch fabrics.
	13	12	Closed overlock	Seam and overcast stretch fabrics in one step.
	14	13	Standard overcast	Seam and overcast stretch fabrics in one step with reinforced edge.
	15	14	Closed overlock	Seam and overcast stretch fabrics in one step.
	16	15	Standard buttonhole	Basic buttonhole for blouses, shirts and jackets. Also for pillowcases.
	17	16	Rounded buttonhole	Buttonhole for garments.
	18	17	Eyelet buttonhole	Tailors buttonhole for jackets and trousers.
	19	18	Stretch buttonhole	Buttonhole for stretch fabrics.
	20	19	Button sewing	Sew on buttons or tacking.
	21	20	Programmable darning stitch	Darning holes or damaged fabric.

Quilt stitches

● = Engage IDT™ system

Stitch																	
3.0	22*	23	24	25	26	27	28	29	30	31	32	33	34	35	36	37	38
2.0	21*	22	23	24	25	26	27	28	29	30	31	32	33	34	35	36	37

Stitch																	
3.0	39	40	41	42	43	44	45	46	47	48	49	50	51	52	53	54	55
2.0	38	39	40	41	42	43	44	-	-	45	46	-	-	-	47	-	-

* Stitch 22 (21 on 2.0) is sewn with monofilament needle thread and increased thread tension to create a handlook effect.

Needle art stitches

● = Engage IDT™ system

Stitch											
3.0	56	57	58	59**	60**	61**	62	63	64	65	66
2.0	-	-	-	48**	49**	50**	-	-	-	-	-

** Stitches 59, 60 and 61 (48, 49 and 50 on model 2.0) are meant to be sewn with a wing needle for a special effect.

Satin stitches

Stitch													
3.0	67	68	69	70	71	72	73	74	75	76	77	78	79
2.0	51	52	-	-	-	-	63	-	53	-	-	54	-

Decorative stitches

Stitch																
3.0	80	81	82	83	84	85	86	87	88	89	90	91	92	93	94	95
2.0	55	56	57	-	58	59	60	-	61	-	62	64	65	-	66	67

Stitch				
3.0	96	97	98	99
2.0	-	68	69	70

Note: Place stabilizer under your fabric for best results when sewing decorative stitches.

Preparations

Unpacking

1. Place the box on a steady, flat surface. Lift the machine out of the box, remove the outer packaging and lift off the machine carrying case.
2. Remove all outer packing material and the plastic bag.

Note: Your PFAFF® passport™ sewing machine is adjusted to provide the best stitch result at normal room temperature. Extreme hot and cold temperatures can affect the sewn result.

Connect to the power supply

Among the accessories you will find the power cord and the foot control.

Note: Consult a qualified electrician if in doubt as to how to connect the machine to the power source. Unplug the power cord when the machine is not in use.

For this sewing machine, foot control model C-9002 manufactured by CHIENHUNG TAIWAN., LTD must be used.

1. Connect the foot control cord to the front socket on the bottom right side of the machine (A).
2. Connect the power cord to the rear socket on the bottom right side of the machine (B). Plug the cord into the wall socket.
3. Press the ON/OFF switch to ON to turn on power and light (C).

Pack away after sewing

1. Switch the main switch off.

Note: After switching off, residual power may still remain in the machine. This may cause the light to stay on for a few seconds while the power is consumed. This is normal behavior for an energy efficient appliance.

2. Unplug the cord from the wall socket and then from the machine.
3. Unplug the foot control cord from the machine. Wind the cord around the foot control for easy storage.
4. Place all accessories in the accessory tray. Slide the tray on to the machine around the free arm.
5. Place the foot control in the space above the free arm.
6. Put on the hard cover.

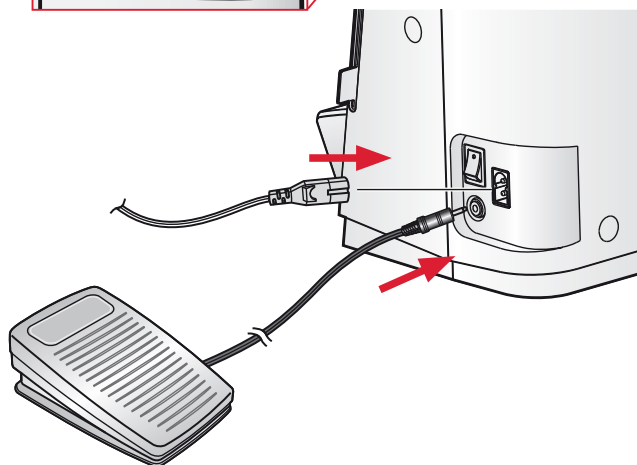
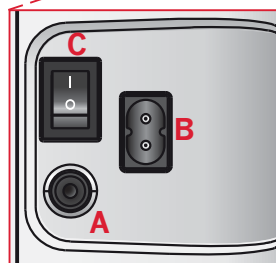
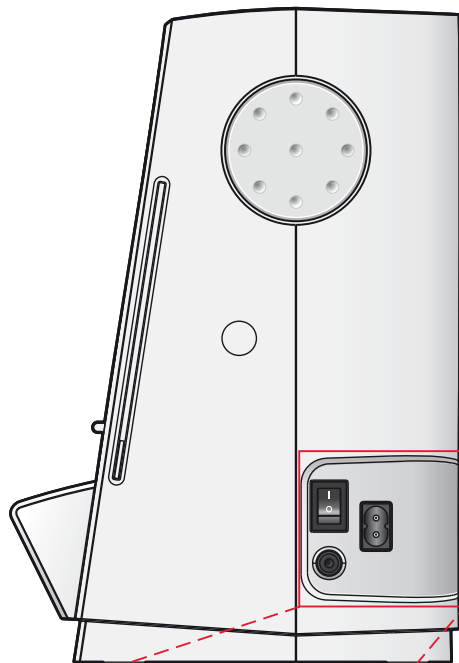

For the USA and Canada

This sewing machine has a polarized plug (one blade wider than the other). To reduce the risk of electric shock, this plug is intended to fit in a polarized outlet only one way. If the plug does not fit fully in the outlet, reverse the plug. If it still does not fit, contact a qualified electrician to install the proper outlet. Do not modify the plug in any way.

Free arm

To use the free arm, slide off the accessory tray. When attached, a hook keeps the accessory tray securely attached to the machine. Remove the tray by sliding it to the left.

Leveling the machine base plate

To make sure your machine stands steadily on your sewing surface you can adjust the base plate height. Turn the base plate adjusting screw (A) by hand. Turn clockwise to lower and counter-clockwise to raise the base plate.

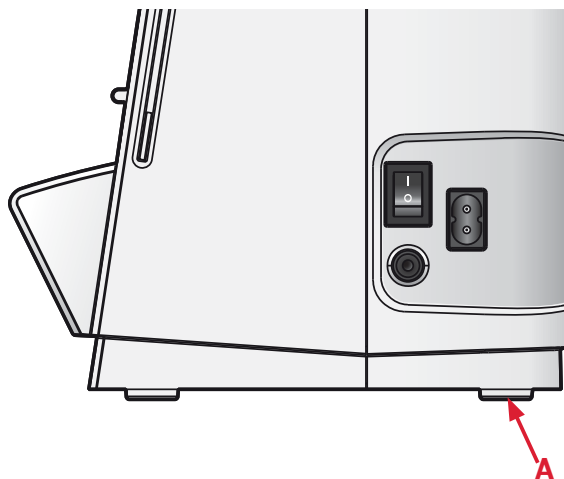

Thread cutter

To use the thread cutter, pull the thread from back to front as shown (B).

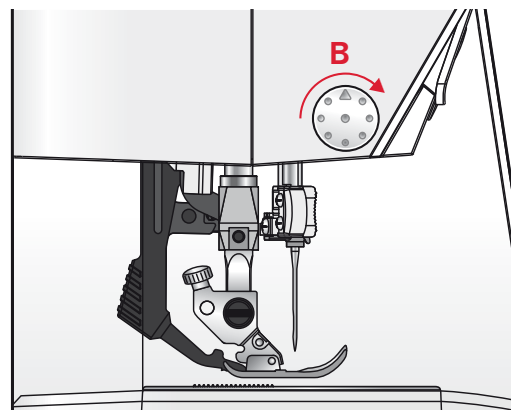

Spool pins

Your machine has two spool pins, a main spool pin and an auxiliary spool pin. The spool pins are designed for many types of thread. The main spool pin is adjustable and can be used both in a horizontal position (the thread reels off the spool) and a vertical position (the thread spool rotates). The horizontal position can be used for most sewing and embroidery threads, and the vertical position can be used for many specialty threads.

Horizontal position

Place a spool cap and the thread spool on the spool pin. Make sure that the thread reels over the top and slide on the second spool cap.

Use a spool cap slightly larger than the thread spool.

For narrow thread spools, use a smaller spool cap in front of the spool. For large thread spools, use a larger spool cap in front of the spool.

The flat side of the spool cap should be pressed firmly against the spool. There should be no space between the spool cap and the thread spool.

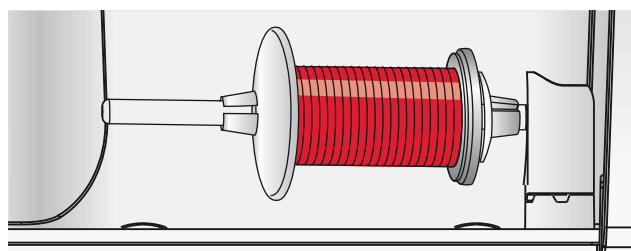

Large spool cap

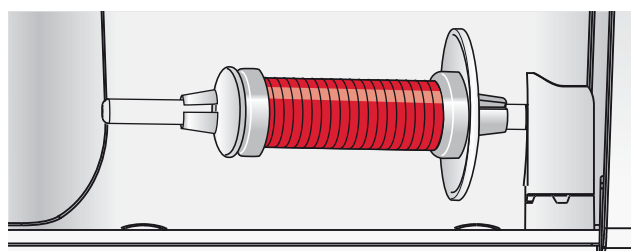

Small spool cap

Vertical position

Raise the spool pin to the vertical position. Slide on the large spool cap and place a felt pad under the thread spool. This is to prevent the thread from reeling off too fast.

Do not place a spool cap on top of the spool pin as that would prevent the spool from rotating.

Auxiliary spool pin

The auxiliary spool pin is used when winding a bobbin thread from a second spool of thread or for a second spool when sewing with a twin needle.

Insert the auxiliary spool pin into the hole at the top of the machine (A). Slide on a large spool cap and place a felt pad under the thread spool.

Threading the machine

Make sure that the presser foot is raised and the needle is in its highest position.

1. Place the thread on the spool pin and fit the appropriately sized spool cap.
2. Pull the thread into the right thread guide (B) from front to back and the left thread guide (C) from back to front. Pull the thread between the tension discs (D).
3. Thread down through the right-hand threading slot and then upwards through the left-hand threading slot.
4. Bring the thread from the right into the take-up lever (E) and down in the left-hand threading slot, into the lower thread guide (F) and to the needle thread guide (G).
5. Thread the needle.

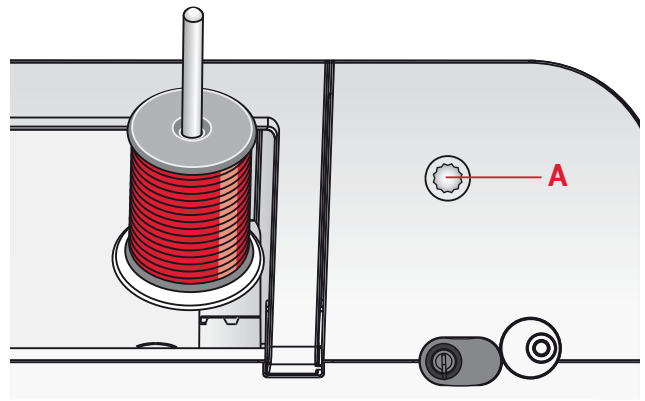
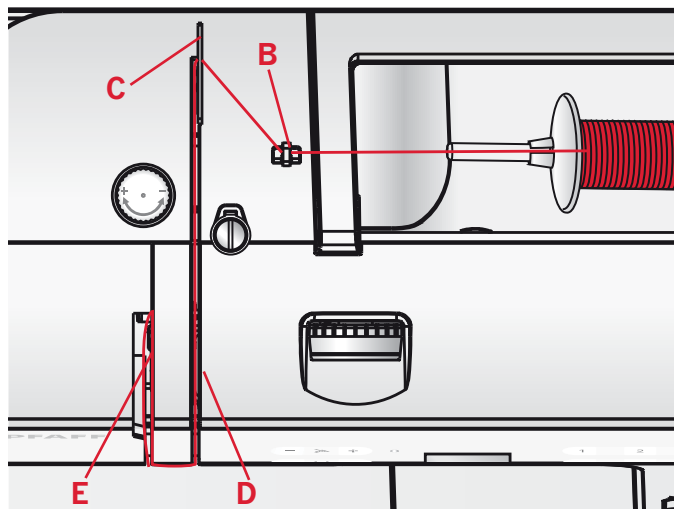

Main spool pin in vertical position.

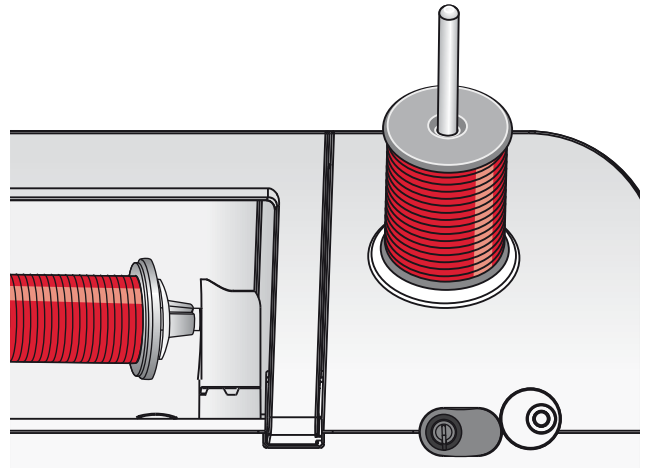

Auxiliary spool pin.

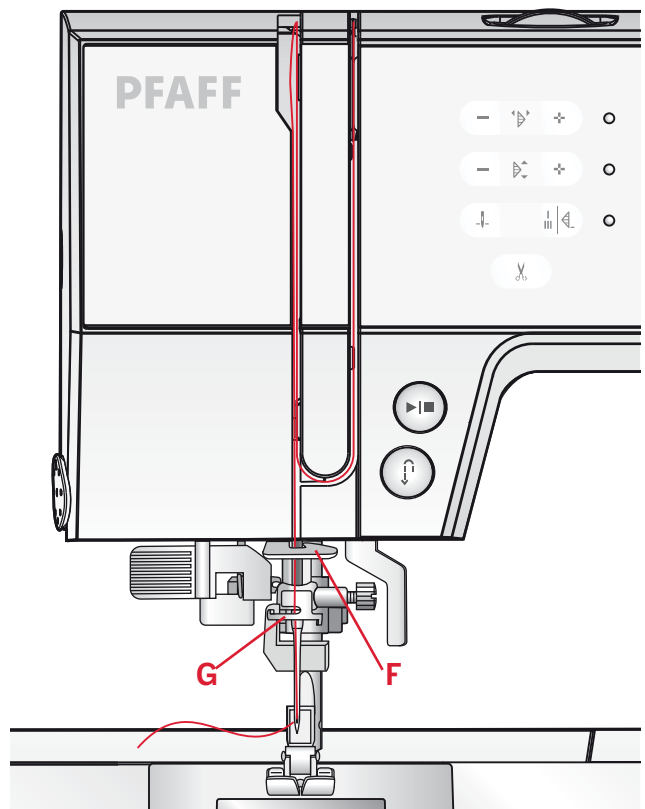

Needle threader

The needle threader allows you to thread the needle automatically. The needle must be in its highest position to use the built-in needle threader. Press the needle up/down button to make sure the needle is fully raised.

We also recommend lowering the presser foot.

1. Use the handle to pull the needle threader all the way down. The threader hook (F) swivels through the needle eye.
2. Place the thread from the back over the hook (G) and under the thread hook (F).
3. Let the needle threader gently swing back. The hook pulls the thread through the needle eye and forms a loop behind the needle. Pull the thread loop out behind the needle.

Note: The needle threader is designed to be used for size 70-120 needles. You cannot use the needle threader for size 60 needles or smaller, wing needles or twin needles. There are also some optional accessories that require manual threading of the needle.

When threading the needle manually, make sure that the needle is threaded from front to back.

Threading for twin needle

Replace the sewing needle with a twin needle. Make sure that the presser foot is raised and the needle is in its highest position.

1. Place the thread on the spool pin and fit the appropriately sized spool cap. Insert the auxiliary spool pin. Slide on a large spool cap and a felt pad. Place the second thread on the spool pin.
2. Pull the thread into the right thread guide (A) from front to back and the left thread guide (B) from back to front. Pull both threads between the tension discs (C).
3. Thread down through the right-hand threading slot and then upwards through the left-hand threading slot.
4. Bring the threads from the right into the take-up lever (D) and down in the left-hand threading slot. Place the threads into the lower thread guide (E). Place one thread into the slot on the left side of the needle thread guide (F) and the other thread into the slot on the right side of the needle thread guide (G). Make sure that the threads do not become twisted together.
5. Thread the needles.

Note: The weight and irregular surface of specialty threads, like metallics, can cause increased tension on the thread. Reducing the tension will prevent needle breakage.

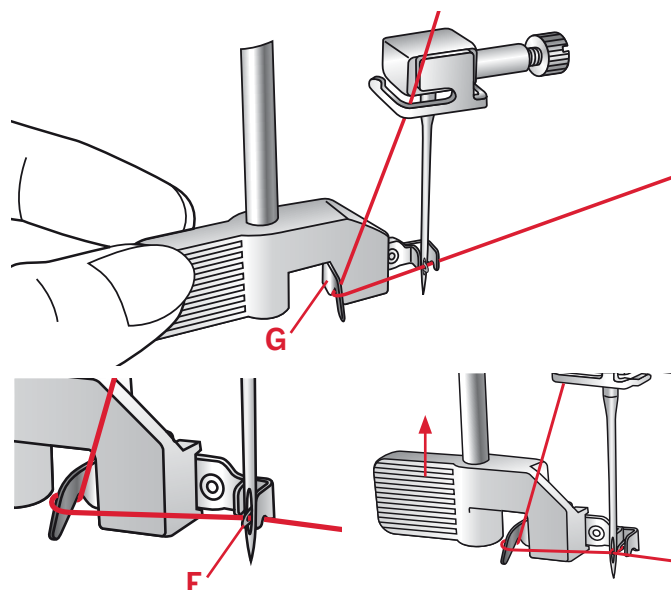

Note: When you are using a twin needle, you might need to reduce the stitch width to prevent damage of the twin needle, stitch plate or presser foot. How much you need to reduce it depends on the stitch position, the stitch width and/or the size of the twin needle.

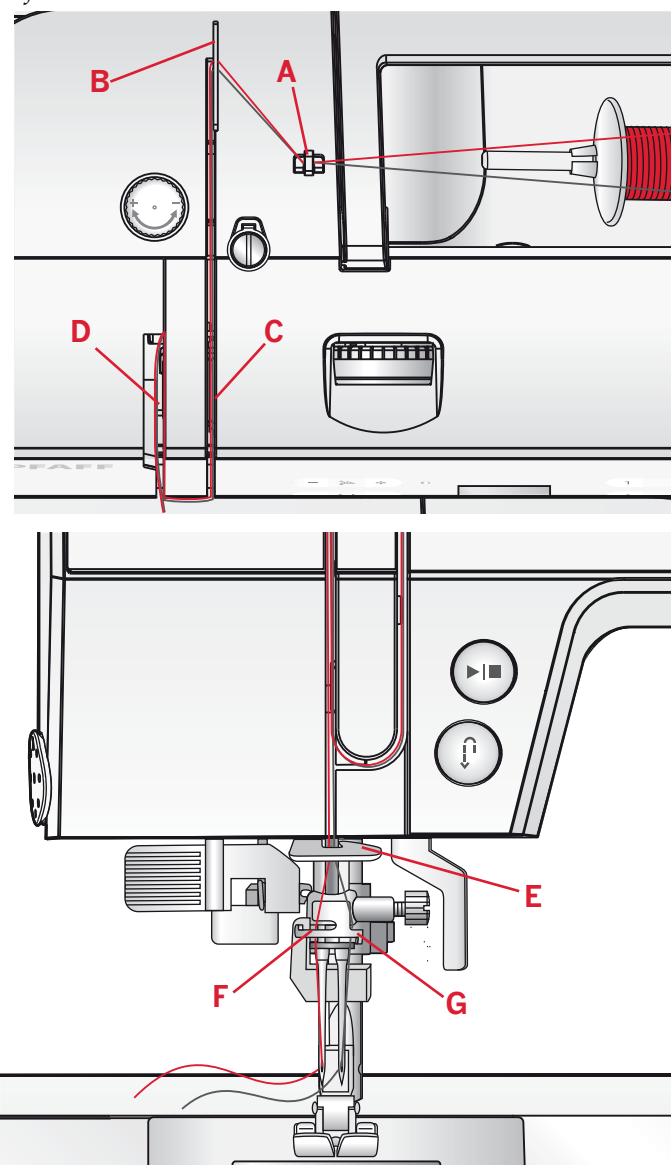

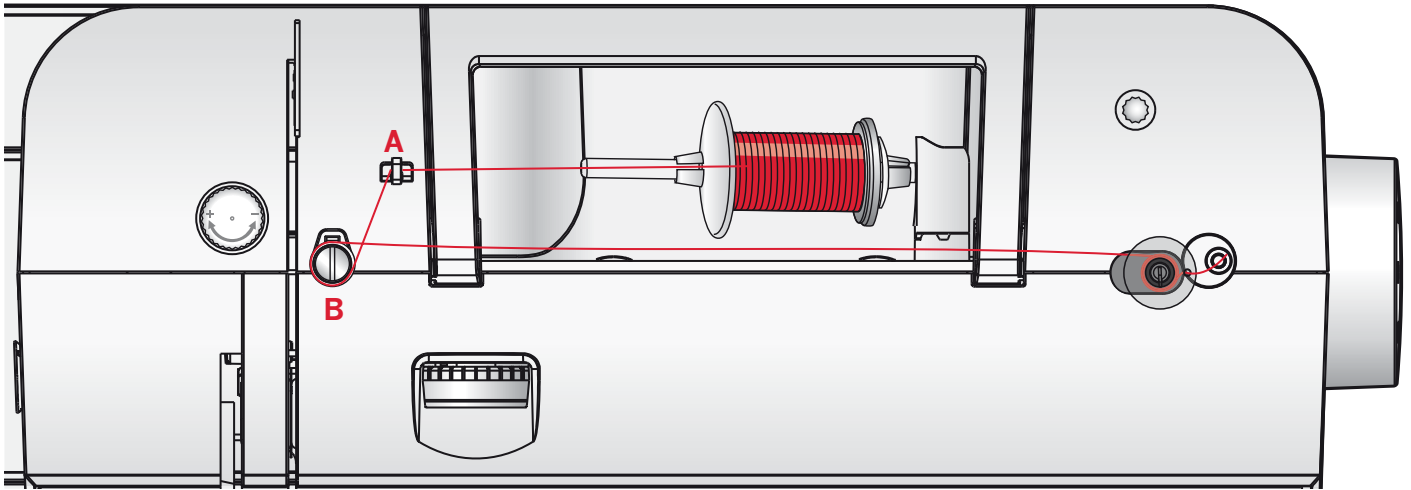

Bobbin winding

1. Place the thread spool on the spool pin in horizontal position. Slide a spool cap tightly against the spool.
2. Place the thread into the thread guide (A) from front to back. Pull the thread clockwise around the bobbin winder tension disc (B).
3. Thread through the hole in the bobbin (C) from the inside to the outside.
4. Place an empty bobbin on the bobbin spindle.
5. Push the bobbin lever to the right to wind.

The letters "SP" flash on the LED display (D).

Press the foot control to wind the bobbin.

When the bobbin is full, release the foot control. Push the bobbin lever to the left. Remove the bobbin and cut the thread.

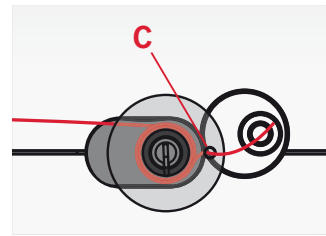

Inserting the bobbin

Make sure that the needle is fully raised and the machine is turned off before inserting or removing the bobbin. Open the bobbin cover by pushing the release button to the right (A). Remove the cover (B).

1. Insert the bobbin in the bobbin case with the thread running in a counterclockwise direction.
2. Pull the thread through the slit (C).
3. With a finger held gently on top of the bobbin, draw the thread at the arrow markings into the stitch plate thread guide from (C) to (D).
4. Pull the thread at the arrow markings into the stitch plate thread guide from (D) to (E).
5. To cut off excess thread pull thread back over the cutting off blade at point (E).
6. Replace the bobbin cover.

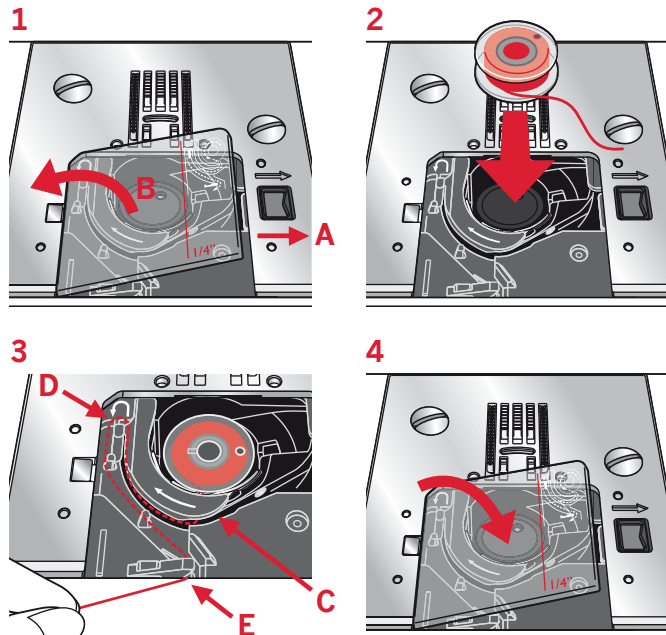

IDT™ system (integrated dual feed)

For sewing any fabric precisely, PFAFF® passport™ sewing machine provides the ideal solution: the integrated dual feed, IDT™ system. As on industrial machines, the IDT™ system feeds the fabric from the top and bottom at the same time. The fabrics are fed precisely. On light fabrics such as silk or rayon the dual feed prevents puckering of the seam. The even feeding action also ensures perfect matching of checked and striped fabrics. The IDT™ system keeps all layers of quilt projects aligned to prevent shifting of the layers.

Engaging the IDT™ system

Important: For all work with the IDT™ system, use presser feet with the center back cut-out (F).

Raise the presser foot. Press the IDT™ system down until it engages.

Disengaging the IDT™ system

Raise the presser foot. Hold the IDT™ system with two fingers at the ribbed ankle. Pull the IDT™ system down, then pull it away from you to release the IDT™ system slowly upward.

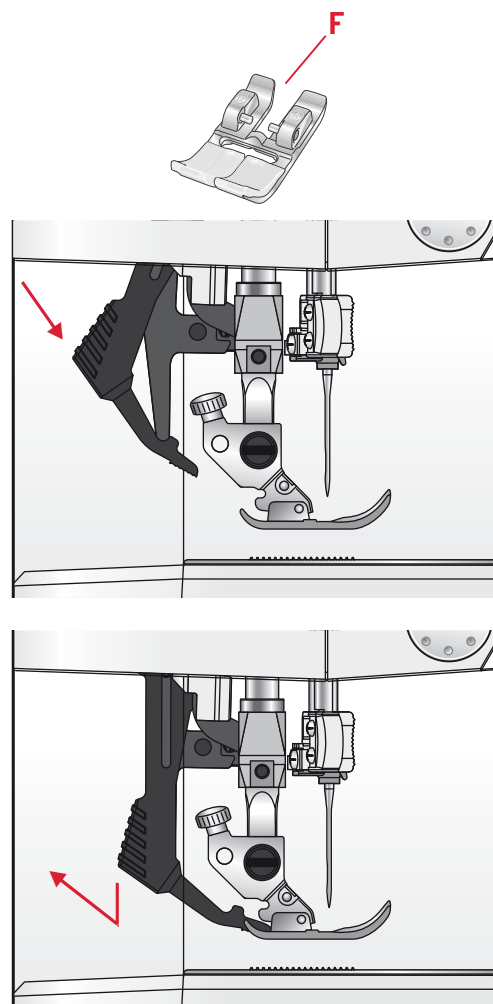

Presser foot pressure

The presser foot pressure has been pre-set to the standard value "N". In most cases, you do not need to adjust the presser foot pressure. When using specialty techniques, or when sewing on very light or heavy fabric, adjusting the pressure can improve the result.

For very light fabrics, loosen the pressure by turning the dial counterclockwise.

Note: If the dial is turned counterclockwise too much, it could come off. If this happens, simply replace the dial and turn it clockwise until it stays in place.

For heavy fabric, tighten the pressure by turning the dial clockwise.

Note: If the dial is turned clockwise until it comes to a stop, it has reached the maximum pressure available. Do not try to turn the dial any further!

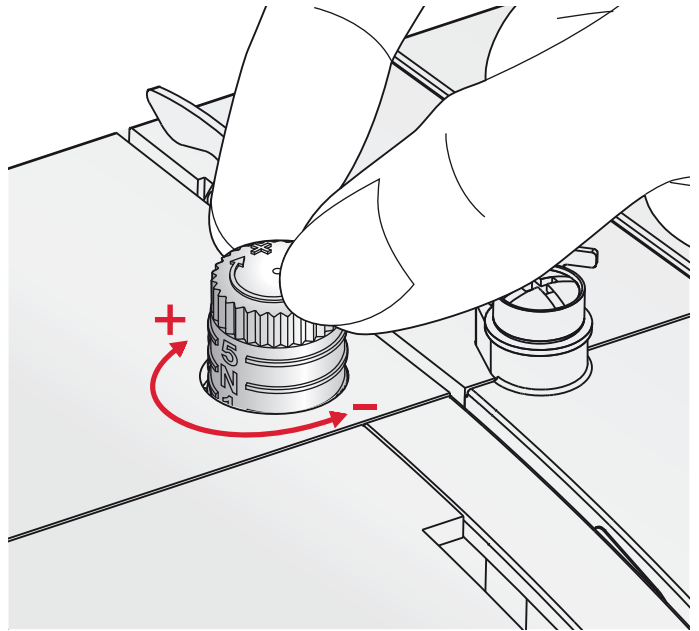

Thread tension

To set the thread tension, turn the dial on top of the machine. Depending on the fabric, batting, thread, etc, the tension may need to be adjusted.

For the best stitch appearance and durability, make sure the needle thread tension is correctly adjusted. For general sewing, the threads evenly meet between the two layers of fabric.

If the bobbin thread is visible on the top side of the fabric, the needle thread tension is too tight. Reduce the needle thread tension.

If top thread is visible on the underside of the fabric, the needle thread tension is too loose. Increase the needle thread tension.

For decorative stitches and buttonholes, the top thread should be visible on the underside of the fabric.

Make a few tests on a scrap piece of the fabric you are going to sew and check the tension.

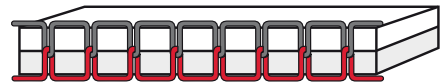
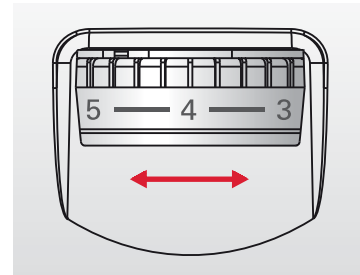

Needles

The sewing machine needle plays an important role in successful sewing. Use only quality needles. We recommend needles of system 130/705H. The needle package included with your machine contains needles of the most frequently used sizes.

Universal needle (A)

Universal needles have a slightly rounded point and come in a variety of sizes. For general sewing in a variety of fabric types and weights.

Stretch needle (B)

Stretch needles have a special scarf to eliminate skipped stitches when there is a flex in the fabric. For knits, swimwear, fleece, synthetic suedes and leathers. Marked with a yellow band.

Embroidery needle (C)

Embroidery needles have a special scarf, a slightly rounded point and a slightly larger eye to avoid damage to thread and materials. Use with metallic and other specialty threads for embroidery and decorative sewing. Marked with a red band.

Denim needle (D)

Denim needles have a sharp point to penetrate tightly woven fabrics without deflecting the needle. For canvas, denim, microfibers. Marked with a blue band.

Wing needles (E)

The Wing needle has wide wings on the side of the needle to poke holes in the fabric when sewing entredeux and other hemstitches on natural fiber fabrics.

Note: Change the needle often. Always use a straight needle with a sharp point (F).

A damaged needle (G) can cause skipped stitches, breakage or snapping of the thread. A damaged needle can also damage the stitch plate.

Do not use asymmetrical twin needles (H), since it may damage your sewing machine.

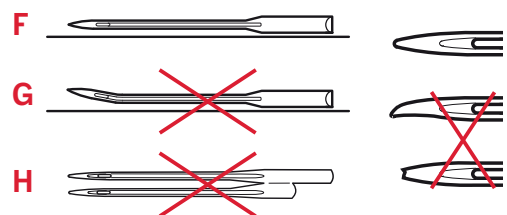
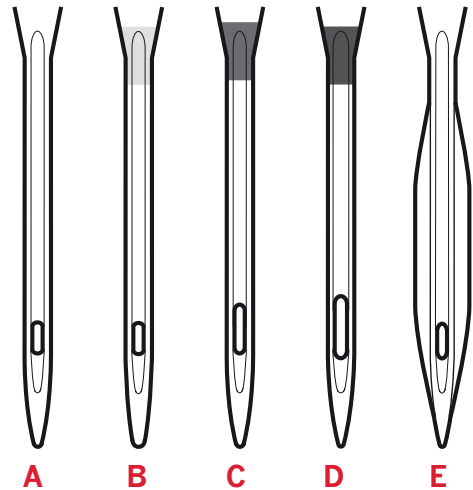

Changing the needle

1. Use the hole in the multi-purpose tool to hold the needle.
2. Loosen the needle screw. Use the screwdriver if necessary.
3. Remove the needle.
4. Insert the new needle, using the multi-purpose tool. Push the new needle upwards with the flat side away from you until it will go no further.
5. Tighten the needle screw as tight as it will go.

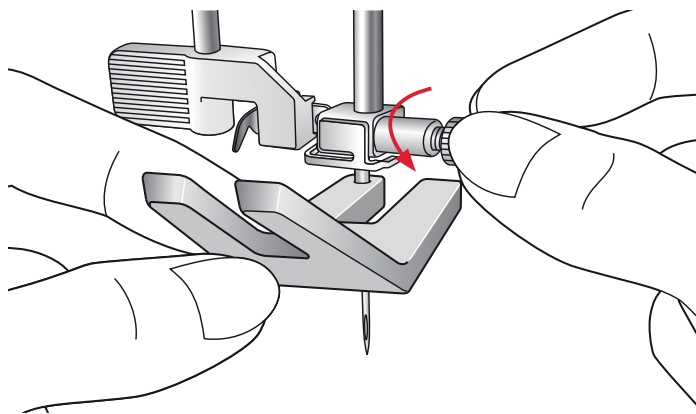

Lowering feed dogs

You can lower the feed dogs by moving the switch at the back of the free arm to the left. Move the switch to the right if you wish to raise the feed dogs.

Note: The feed dogs will not raise immediately when the lever is switched. Turn the handwheel one full turn or start sewing to re-engage the feed dogs.

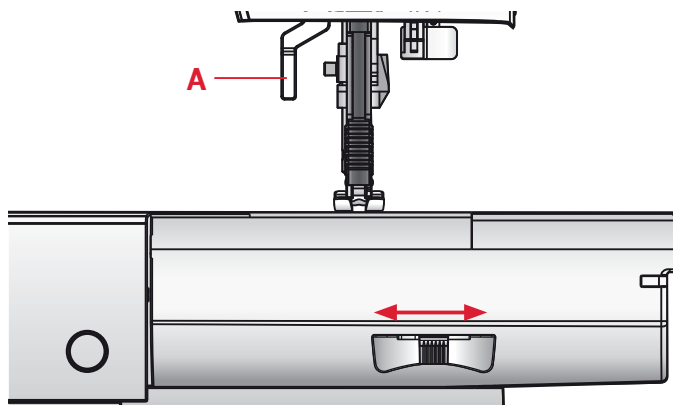

Presser foot lift

The presser foot is lowered or raised with the presser foot lift (A). If you are sewing on heavy fabric or several layers of fabric, the presser foot can be raised higher to make it easier to place the fabric underneath the presser foot.

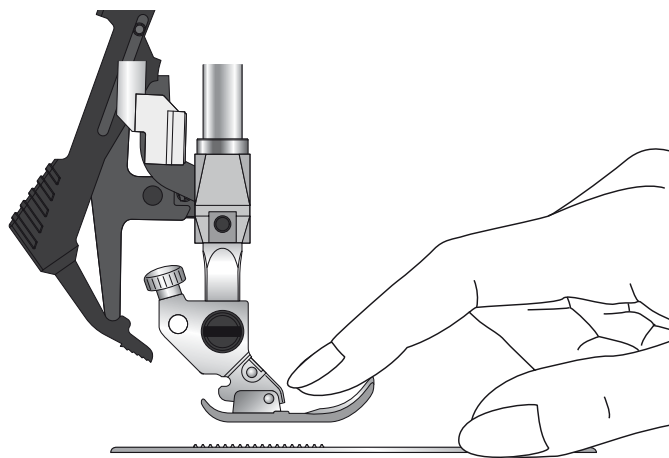

Changing the presser foot

Remove presser foot

Press the presser foot downwards until it disengages from the presser foot holder.

Attach presser foot

Place the presser foot under the presser foot holder (B), lining up the notch (C) with the pins (D).

Lower the presser foot lift and the presser foot will engage in the presser foot holder.

Note: Check that the presser foot is properly attached by raising the presser foot lift.

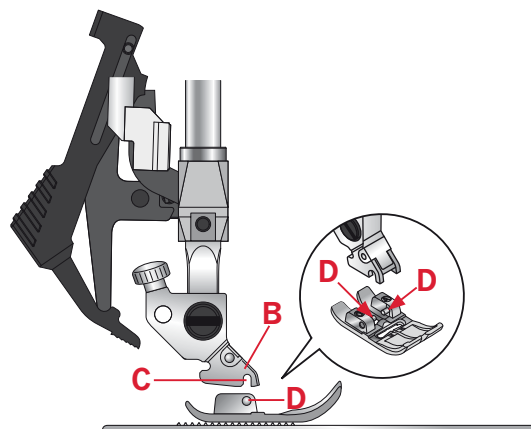

Buttons passport™ 3.0

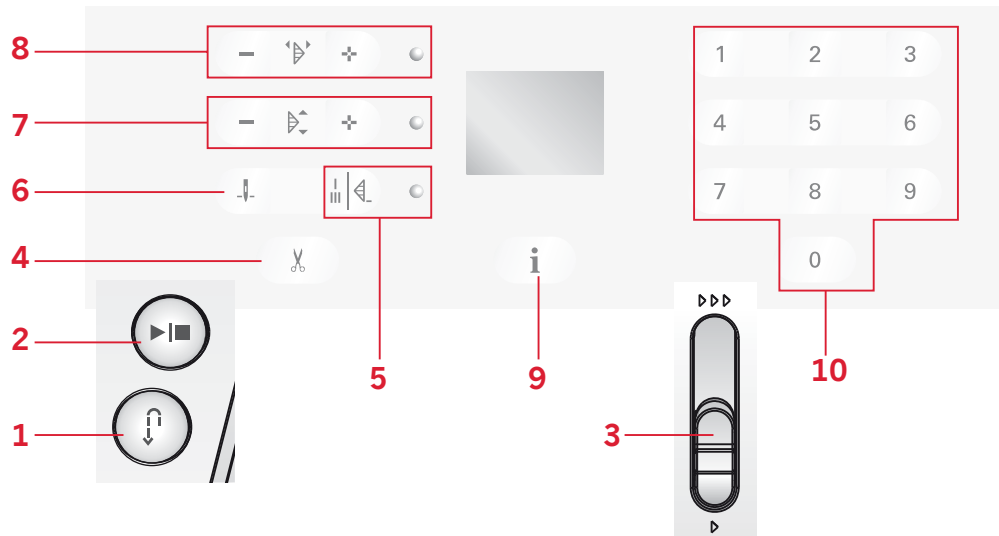

Reverse (1)

If you press the reverse button while sewing, the machine sews in reverse for as long as you keep the button pressed.

Reverse is also used when sewing the darning stitch.

Start/stop (2)

Press this button to start or stop the machine without using the foot control. Press the button once to start and press it again to stop.

Speed control lever (3)

The speed control lever sets the maximum sewing speed. To increase sewing speed, slide the lever up, to decrease sewing speed, slide the lever down.

Thread snips (4)

Press this button when you are not sewing and the machine cuts the top and bobbin threads. Press this button while sewing and the machine will finish the stitch, perform a tie-off and cut the top and bobbin threads.

Immediate tie-off/Tie-off (5)

For immediate tie-off press the button while sewing. The machine sews tie-off stitches immediately and stops automatically.

To set the machine to perform a tie-off at the end of a stitch, press the button before starting to sew. The LED light next to the button becomes lit. After sewing the desired length of stitching, press the reverse button while actively sewing. The machine will complete the current stitch, tie-off and stop automatically.

Note: The tie-off function is not available for stitches 16-21.

Needle up/down (6)

Press this button to move the needle up or down. The setting of the needle stop position is changed at the same time.

You can also tap the foot control to raise or lower the needle.

Stitch length (7)

Increase or decrease the stitch length using the "+" and "-" buttons.

Stitch width or stitch positioning (8)

Increase or decrease the stitch width using the "+" and "-" buttons.

For straight stitches, use the "+" and "-" buttons to change the stitch position.

Note: There are 29 needle positions available. 3.5 on the display is the center position.

Info button (9)

Press this button to show the presser foot recommendation on the LED display. If a dot is visible in the lower right corner of the screen, the IDT™ system should be engaged.

Stitch selection (10)

Press a combination of the 0 to 9 buttons to select the stitch represented by that number.

Buttons passport™ 2.0

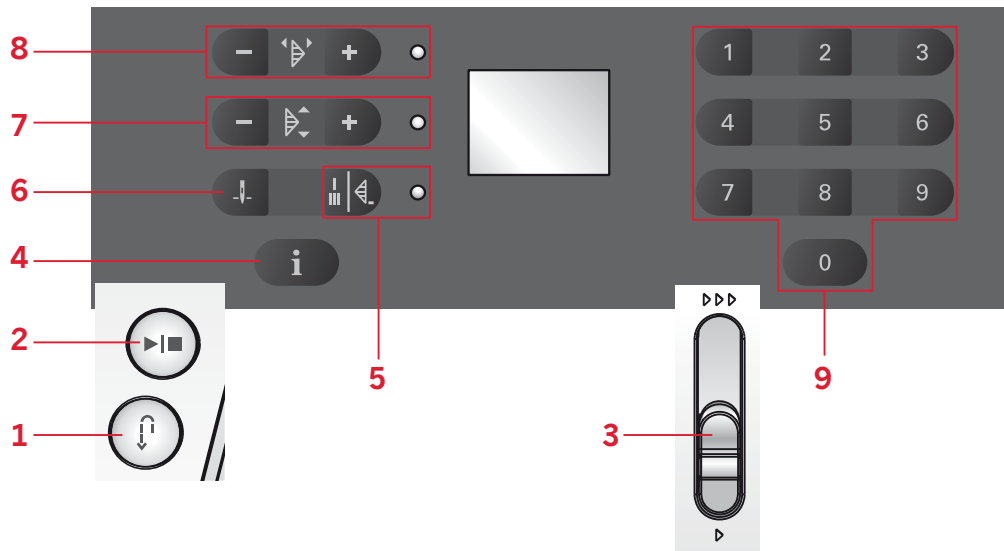

Reverse (1)

If you press the reverse button while sewing, the machine sews in reverse for as long as you keep the button pressed.

Reverse is also used when sewing the darning stitch.

Start/stop (2)

Press this button to start or stop the machine without using the foot control. Press the button once to start and press it again to stop.

Speed control lever (3)

The speed control lever sets the maximum sewing speed. To increase sewing speed, slide the lever up, to decrease sewing speed, slide the lever down.

Info button (4)

Press this button to show the presser foot recommendation on the LED display. If a dot is visible in the lower right corner of the screen, the IDT™ system should be engaged.

Immediate tie-off/Tie-off (5)

For immediate tie-off press the button while sewing. The machine sews tie-off stitches immediately and stops automatically.

To set the machine to perform a tie-off at the end of a stitch, press the button before starting to sew. The LED light next to the button becomes lit. After sewing the desired length of stitching, press the reverse button while actively sewing. The machine will complete the current stitch, tie-off and stop automatically.

Note: The tie-off function is not available for stitches 15-20.

Needle up/down (6)

Press this button to move the needle up or down. The setting of the needle stop position is changed at the same time.

You can also tap the foot control to raise or lower the needle.

Stitch length (7)

Increase or decrease the stitch length using the "+" and "-" buttons.

Stitch width or stitch positioning (8)

Increase or decrease the stitch width using the "+" and "-" buttons.

For straight stitches, use the "+" and "-" buttons to change the stitch position.

Note: There are 29 needle positions available. 3.5 on the display is the center position.

Stitch selection (9)

Press a combination of the 0 to 9 buttons to select the stitch represented by that number.

Warning messages/sound

Main motor overloaded

Your sewing machine can get overloaded when sewing on heavy fabrics e.g., the thread gets twisted or jammed or the hand wheel axle cannot move. A monotone beep sound is heard and the letters "EL" flash on the LED display. Please refer to the troubleshooting on page 29 to find a recommended solution. When the problem has been solved, the machine will continue to sew.

Note: When sewing, if the thread gets jammed inside the hook preventing the needle from moving and you continue pressing the foot control, the security switch will stop the machine completely. Restart the sewing machine by switching the ON/OFF switch to the OFF position and then ON again.

Note: If the problem is still not solved, please contact your local authorized PFAFF® dealer.



Bobbin winding position

When the bobbin lever is pushed to the right, the letters "SP" flash on the LED display.

If you press any button, a beep will inform you to push the bobbin winder spindle to the left, sewing position.

Note: You cannot sew in bobbin winding position.



Machine sound

It is possible to turn off the sound on the machine buttons. Press the immediate tie-off button (A) while turning on the machine.

Select between the audio on or off by touching the stitch width "+" or "-" buttons (B).

Touch "-" to turn off the audio and the display will show "0". Touch "+" to turn on the audio and the display will show "1".

Press the immediate tie-off button again to return to sewing mode.

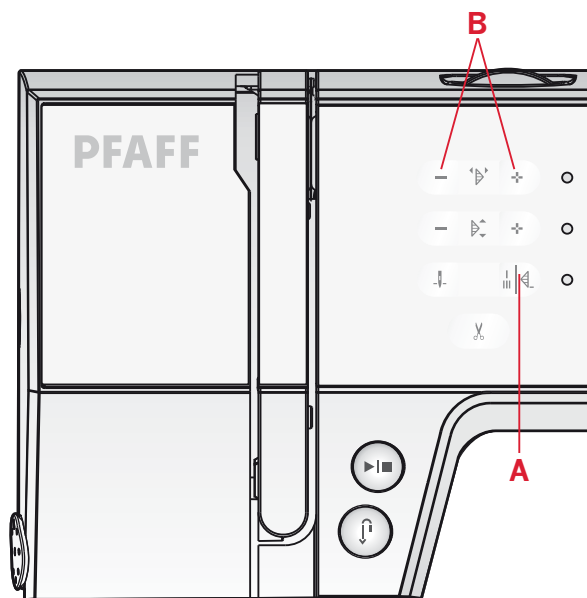

Sewing

When the machine is turned on, straight stitch 00 (01 on 2.0) is selected by default.

Select a stitch

Press a combination of the 0 to 9 buttons to select the stitch represented by that number.

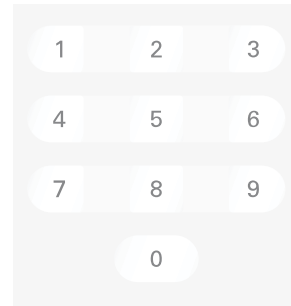

Stitch adjustments

Your machine will automatically set the length (A) and width/positioning (B) for the selected stitch. You can make your own adjustments on the selected stitch.

The setting changes only affect the selected stitch, and will be reset to default when another stitch is selected. The changed settings are not automatically saved when turning your machine off.

Press "+" or "-" once next to the setting you wish to change. The set value will be indicated in numbers on the display and the LED light (C) next to the setting control lights up. Change the set value by pressing the "+" or "-" button when the LED light is lit.

When trying to exceed minimum or maximum settings a warning sound will be heard.

Note: The default value of a setting will flash on the display when scrolling through the setting values.

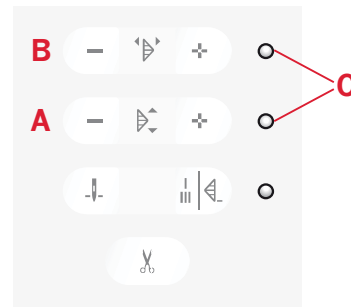

Sewing techniques

Three-step zigzag stitch

Stich number 05 (06 on 2.0) can be used to overcast raw edges. Make sure the needle pierces the fabric on the left side and overcasts the edge on the right side.

Stich number 05 (06 on 2.0) can also be used as an elastic stitch to allow seams to stretch when sewing knit fabrics.

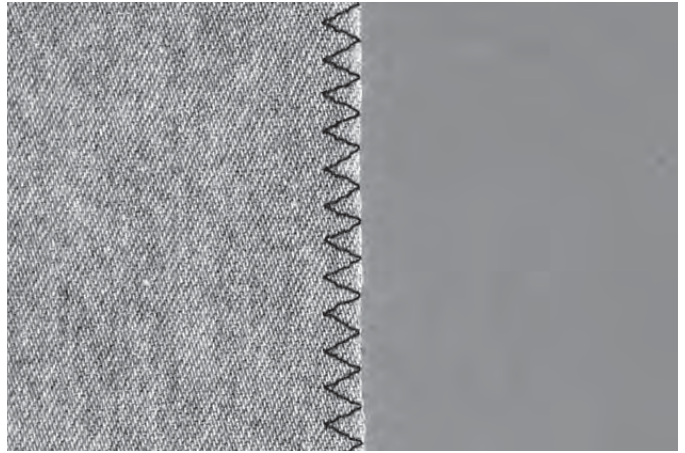

Buttonholes

Your machine's buttonholes are specially adjusted for different kinds of fabric and garments. Look at the stitch table on page 7 in this book to find descriptions of each buttonhole.

The fabric should be interfaced and/or stabilized where buttonholes are to be sewn.

One step Buttonhole Foot 5B

1. Mark the the position of the buttonhole on your garment.
2. Attach buttonhole foot 5B and pull out the button holder plate. Insert the button. The button will determine the length of the buttonhole.
3. Make sure that the thread is pulled though the hole in the presser foot and placed under the foot.
4. Select the buttonhole you want to sew and adjust the length as desired.

Note: Always sew a test buttonhole on a scrap piece of fabric.

5. Position your garment under the presser foot so that the marking on the fabric is aligned with the center of the buttonhole foot.
6. Lower the buttonhole lever all the way down, and push it away from you.
7. Hold the end of the upper thread and start sewing. The buttonholes are sewn from the front of the presser foot to the back.
8. Once the machine has sewn the buttonhole, raise the presser foot.

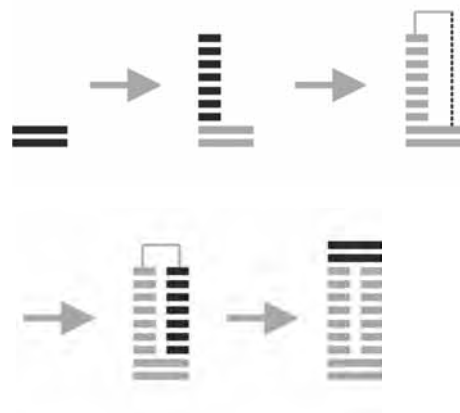
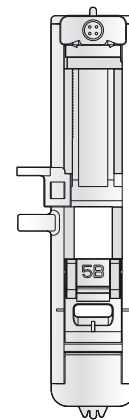

Corded buttonhole (Stretch fabrics)

When sewing buttonholes in stretch fabrics we recommend cording the buttonhole to increase the stability and to keep the buttonhole from stretching out.

1. Loop a piece of heavy thread or pearl cotton over the finger at the back of the buttonhole foot 5B. Pull the thread tails under the foot, toward the front, then secure around the finger at the front of the foot.
2. Stitch a buttonhole. The satin buttonhole columns will stitch over the cord.
3. When the buttonhole is finished, lift the cord off the finger and pull out the slack.
4. Cross the cord in front of the needle and thread cord ends into a large needle, pull to the wrong side and knot ends before cutting excess.
5. Use the seam ripper to carefully open the buttonhole.

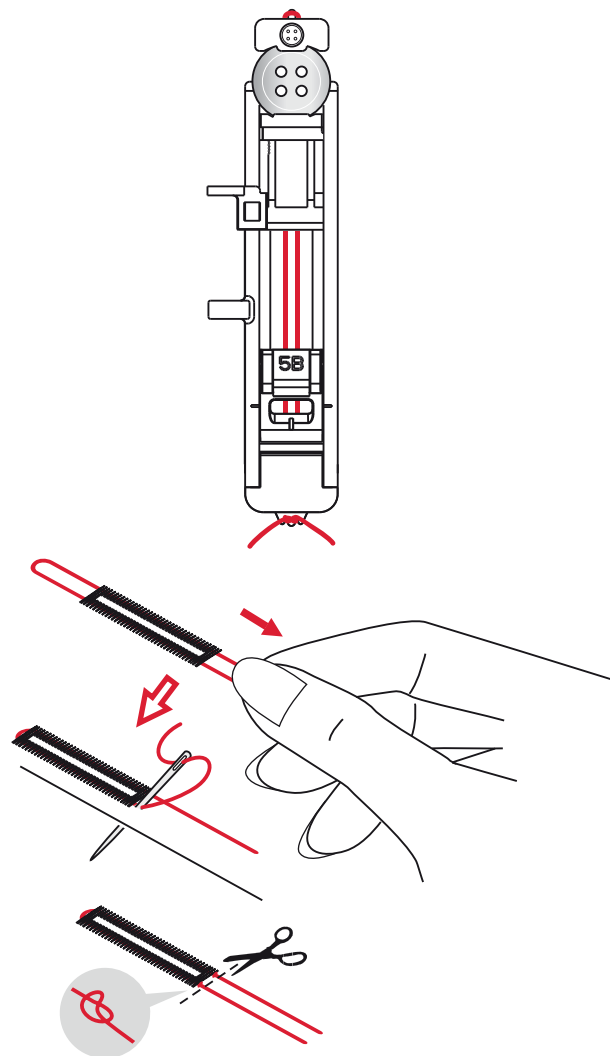

Sew on a button

1. To sew on a button, remove the presser foot and select the button sewing stitch, number 20 (19 on 2.0).
2. Lower the feed dogs.
3. Place the button under the presser foot holder. Turn the handwheel slowly to make sure the holes in the button are aligned with the swing of the needle and the width is appropriate for the actual button. If necessary, adjust the stitch width to accommodate the width between the holes.
4. You can increase or decrease the number of stitches that will fasten the button on the fabric in steps of two, using the stitch length buttons (A). The set number of stitches is indicated on the display. 6 stitches is default.
5. Start to sew. The machine will sew the program for you and then tie-off and stop.

Note: Use the multi-purpose tool to create a thread shank for your button. You can also use the Sew-on Button Foot #820 473-96, available as an optional accessory.

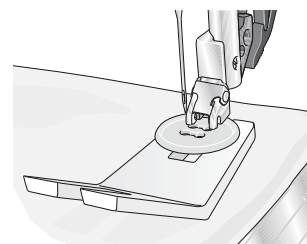
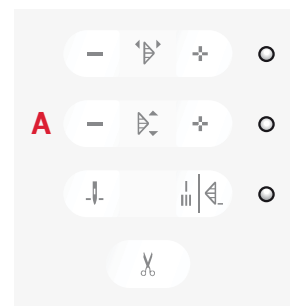

Darning and mending

Darning a small hole or a tear before it becomes larger can save a garment. Choose a thread in a color as close to your garment as possible.

1. Place fabric or stabilizer in position under the hole or tear in your garment.
2. Select stitch number 21 (20 on 2.0), the darning stitch.
3. Start sewing above the hole and over it.
4. Once you have sewn across the hole, press the reverse button (A) to set the length of the stitch. Your sewing machine will automatically complete the stitch.
5. By default, the machine will be set to repeat the same size darning square, just continue sewing.

To set a different length of the darning stitch, select the stitch again and continue with steps 3 and 4 above.

Note: Darning stitches can also be sewn using the buttonhole foot 5B. Set the length of the darning stitch by pulling out the button holder plate and lower the buttonhole lever to sew the stitch.

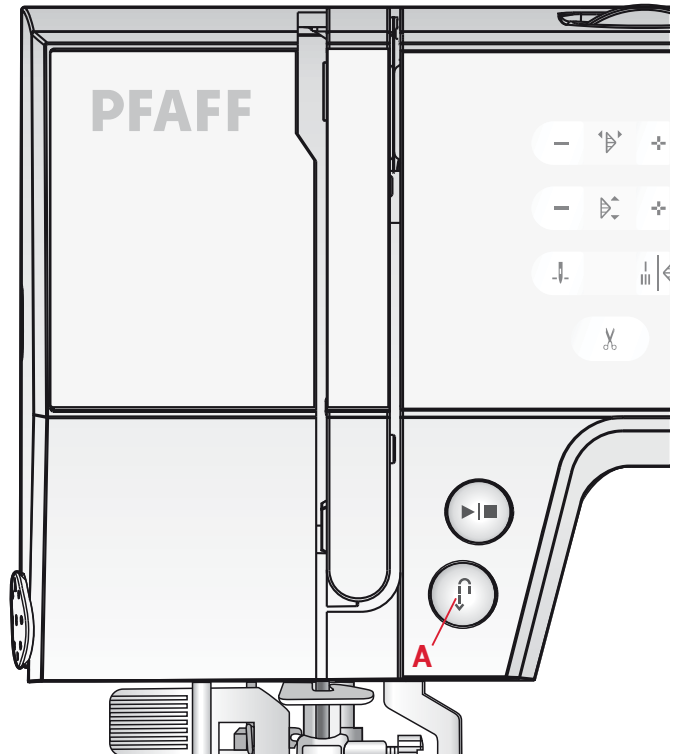

Sewing hems in heavy fabric

When sewing over seams in extra heavy fabric or a blue jeans hem, the foot can tip as the machine climbs over the seam. Use the multi-purpose tool to balance the height of the presser foot as you sew.

One side of the multi-purpose tool is thicker than the other. Use the side that suits the thickness of the seam best.

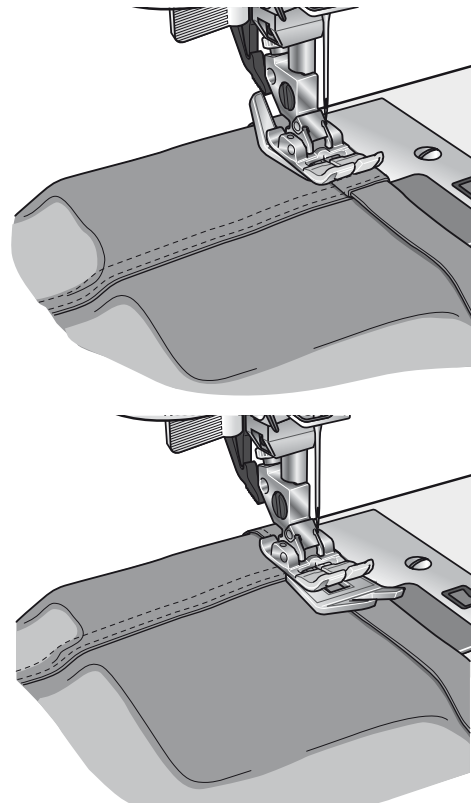

Quilting

A quilt usually consists of three layers, two layers of fabric with a layer of batting sandwiched between.

To sew three layers together, you have a wide variety of stitches and techniques to choose from.

Stitch-in-the-Ditch

Use the Fancy stitch foot 1A with IDT™ system. Stitching in the ditch means using the guide on the presser foot to follow the seams in the quilt blocks.

Begin by pin basting your quilt through all layers with safety pins, starting from the center of your quilt and working out. Place a pin every 6-8 inches (15-20 cm).

Note: You can also use the optional Stitch-in-Ditch w IDT™ system presser foot #820 925- 096.



Crazy quilt stitching

Embellish your quilt with decorative stitches. The stitches can be sewn in a coordinating or contrasting color. Decorative threads like rayon embroidery or heavy cotton threads are sometimes used.

Free-motion stippling

Free-motion stippling not only keeps the top, batting and backing together, but it also adds texture and interest to your quilt.

Free-motion stippling is done with the feed dogs lowered. You move the fabric manually to determine the stitch length.

1. Set your sewing machine for stippling by selecting the straight stitch, number 00 (01 on 2.0).
2. Attach the optional Open Toe Free-Motion foot #820 988-096.
3. Lower the feed dogs.
4. Pin baste your quilt layers and prepare your quilt as explained under Stitch-in-the-Ditch above.

Tip! Practice stippling on scraps of fabric and batting. Sewing with a constant speed will help to keep the stitches even.

5. Begin near the center of your quilt. Take one stitch and pull the bobbin thread to the top of the quilt. Take a few stitches right next to one another to lock the threads.
6. Now move the quilt so that your stitching creates swirls. The stitching should not cross over itself, and should travel in a meandering motion.

Handlook quilting

1. Baste the completed quilt top to the batting and backing.
2. Thread the needle with an invisible (monofilament) thread. Use contrasting or matching rayon or cotton thread in the bobbin.
3. Select the handlook quilt stitch, number 22 (21 on 2.0), and increase the needle thread tension to 7-9.
4. Snap on the recommended presser foot 0A.
5. Engage the IDT™ system.
6. When you sew the stitch you should only see your bobbin thread. Fine adjust the needle thread tension as needed to produce the desired effect.

Blindhem

The blindhem stitch, number 10 (09 on 2.0), is used to make invisible hems on skirts, trousers and home decorating. Use foot number 3 with IDT™ system.

1. Finish the edge of the hem.
2. Fold and press the hem allowance to the wrong side.
3. Fold the hem back on itself so approximately 3/8" (1 cm) of the finished edge extends beyond the fold. The wrong side of your project should now be facing up.
4. Place the fabric under the presser foot so that the fold runs along edge guide A.
5. When the needle swings into the fold it should catch a small amount of fabric. If the stitches are visible on the right side, adjust edge guide A by turning adjusting screw B until the stitch that catches the hem just barely shows.

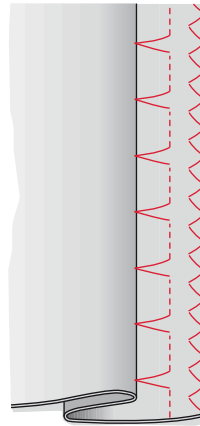
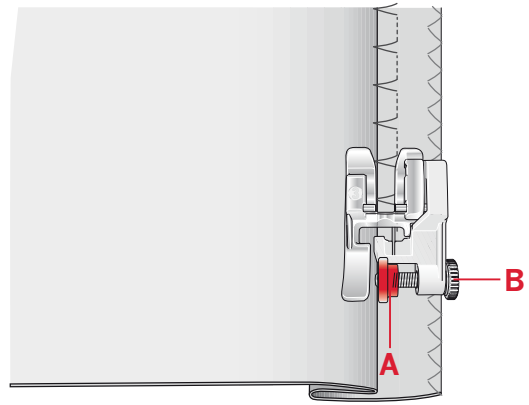

Blindhem stitch, number 10 (09 on 2.0)

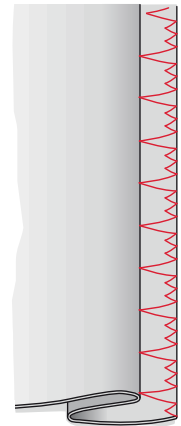

Elastic blindhem stitch, number 11 (10 on 2.0)

Elastic blindhem stitch

The elastic blindhem stitch, number 11 (10 on 2.0), is especially suitable for stretchy fabrics, because the zigzag in the stitch lets the stitch stretch. The hem is finished and sewn at the same time. There is no need to finish the raw edge first on most knits.

Sewing in zippers

There are different ways to sew in zippers. Follow the directions included with your pattern for best results.

For all types of zippers it is important to sew close to the teeth of the zipper. The zipper foot 4 can be snapped to the presser foot bar on the left or right, depending on how you will insert your zipper.

Set the stitch position so the needle enters close to the edge of the zipper teeth by using one of the 29 needle positions available for the straight stitch. If the presser foot is attached on the right side, the needle must only be moved to the right. If the foot is attached on the left, the needle must only be moved to the left.

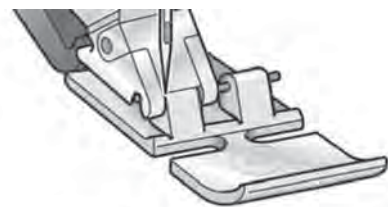
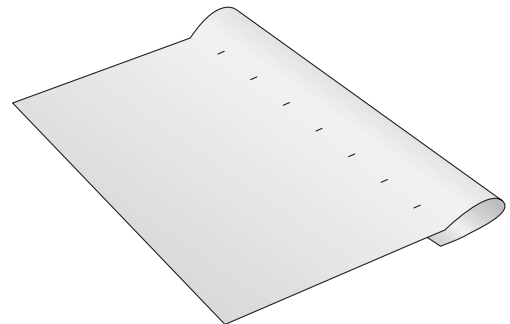

Maintenance

Cleaning the machine

To keep your sewing machine operating well, clean it often. No lubrication (oiling) is needed.

Wipe the exterior surface of your machine with a soft cloth to remove any dust or lint built up.

Cleaning the bobbin area

 *Note: Raise the needle, lower the feed dogs and turn off the machine.*

Remove the presser foot. Push the bobbin cover release button (A) to the right and remove the bobbin cover (B) and the bobbin. Use the screwdriver to remove the two screws (C) in the stitch plate. Lift up the stitch plate.

Clean the feed dogs and the bobbin area with the brush found with the accessories.

Cleaning under the bobbin area

Clean the area under the bobbin case after sewing several projects or any time you notice an accumulation of lint in the bobbin case area.

Remove the bobbin case by lifting it up and to the right. Clean the area with the brush or with a dry cloth.

Put the bobbin case back into the hook race so that the tip fits into the stopper (D).

Note: Do not blow air into the bobbin case area. The dust and lint will be blown into your machine.

Replacing the stitch plate

With the feed dogs lowered, replace the stitch plate and insert and tighten the two stitch plate screws. Replace the bobbin cover.

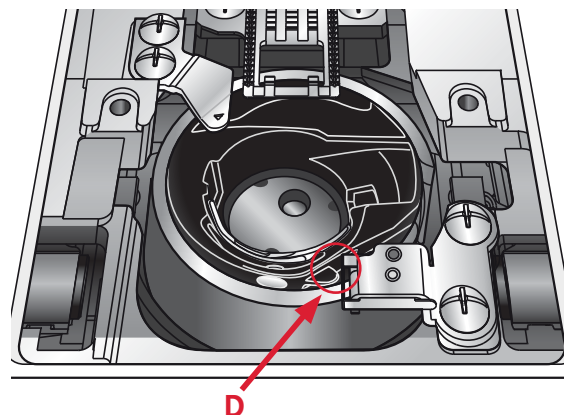
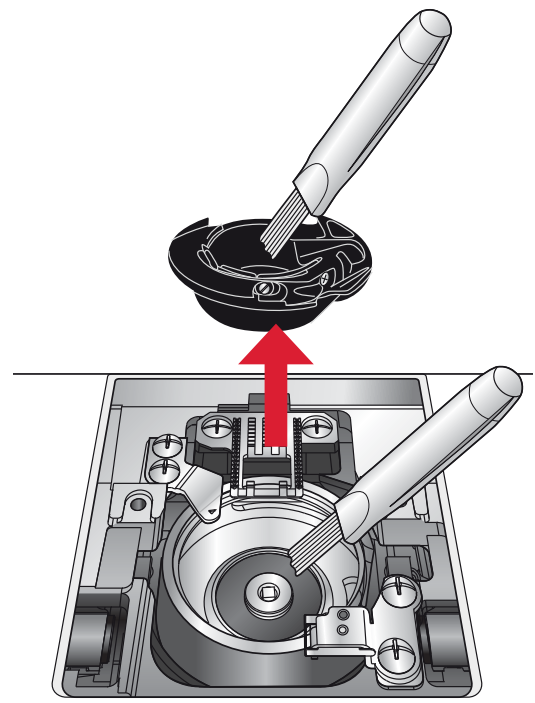
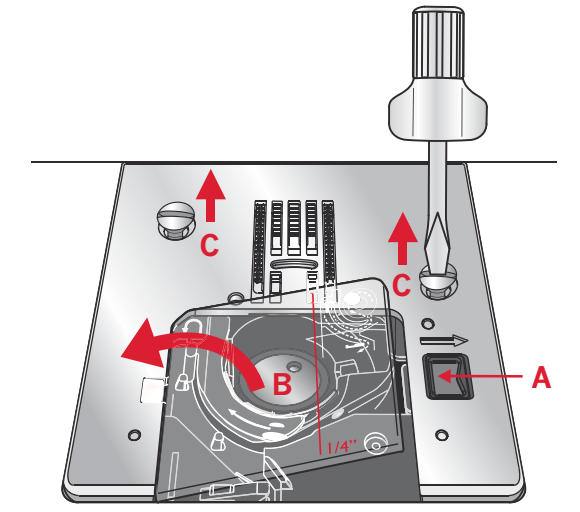

Troubleshooting

In this troubleshooting guide you will find solutions to the problems you may have with your machine. For further information please contact your local authorized PFAFF® dealer.

Problem/cause	Remedy
General problems	
Fabric does not move?	Make sure that the feed dogs are not lowered.
The needle breaks?	Insert needle correctly, see page 17. Attach correct needle for the fabric.
The machine will not sew?	Check that all plugs are securely plugged into the machine and into the wall socket. Push bobbin winder lever to sewing position.
The sewing machine function buttons do not respond to touch?	The sockets and function buttons on the machine can be sensitive to static electricity. If the buttons do not respond to touch, turn the machine OFF and then ON again. If the problem persists, contact your local authorized PFAFF® dealer.

The machine skips stitches	
Did you insert the needle properly?	Insert needle correctly, see page 17.
Did you insert a wrong needle?	Use needle system 130/705 H.
Is the needle bent or blunt?	Insert a new needle.
Did you thread the machine properly?	Check how the machine is threaded.
Is the correct presser foot used?	Attach correct presser foot.
Is the needle too small for the thread?	Make sure the needle is correct for the thread and fabric.

Needle thread breaks	
Did you insert the needle properly?	Insert needle correctly, see page 17.
Did you insert a wrong needle?	Use needle system 130/705 H.
Is the needle bent or blunt?	Insert a new needle.
Did you thread the machine properly?	Check how the machine is threaded.
Is the needle too small for the thread?	Change the needle to the proper size for the thread.
Are you using poor thread with slubs or thread which has become dry?	Change to a new higher quality thread purchased from an authorized PFAFF® dealer.
Is a correct spool cap used?	Attach a spool cap of the right size for the actual thread spool.
Is the best spool pin position used?	Try a different spool pin position (vertical or horizontal).
Is the stitch plate hole damaged?	Change the stitch plate.

Bobbin thread breaks	
Did you insert the bobbin properly?	Check the bobbin thread.
Is the stitch plate hole damaged?	Change the stitch plate.
Is the bobbin area clean?	Clean lint from bobbin area.
Is the bobbin wound correctly?	Wind a new bobbin.

The seam has uneven stitches

Is the thread tension correct?	Check needle thread tension and the threading.
Are you using too thick or slubbed thread?	Change the thread.
Is the bobbin thread evenly wound?	Check bobbin winding.
Is a correct needle used?	Insert a proper needle correctly, see page 17.

The machine does not feed or feeds irregularly

Did you thread the machine properly?	Check how the machine is threaded.
Has sewing lint collected between the feed dogs?	Remove the stitch plate and clean the feed dogs with a brush.

The main motor becomes overloaded

Has the thread become twisted or jammed in the bobbin case area or the feed dogs?	Remove the stitch plate and clean threads and lint from the feed dogs and bobbin case area. Re-thread the machine, both top and bobbin threads.
---	--

We reserve the right to change the machine equipment and the assortment of accessories without prior notice, or make modifications to the performance or design. Such modifications, however, will always be to the benefit of the user and the product.

Intellectual property

PFAFF, PERFECTION STARTS HERE, PASSPORT and IDT (image) are trademarks of KSIN Luxembourg II, S.ar.l.



Please note that on disposal, this product must be safely recycled in accordance with relevant National legislation relating to electrical/electronic products. Do not dispose of electrical appliances as unsorted municipal waste, use separate collection facilities. Contact your local government for information regarding the collection systems available. When replacing old appliances with new ones, the retailer may be legally obligated to take back your old appliance for disposal free of charge.

If electrical appliances are disposed of in landfills or dumps, hazardous substances can leak into the groundwater and get into the food chain, damaging your health and well-being.

CE - Authorised Representative
VSM Group AB, SVP Worldwide
Drottninggatan 2, SE-56184, Huskvarna, SWEDEN



www.pfaff.com